



(11) **EP 2 437 671 B1**

(12) **EUROPEAN PATENT SPECIFICATION**

(45) Date of publication and mention of the grant of the patent:
14.08.2019 Bulletin 2019/33

(21) Application number: **10732753.8**

(22) Date of filing: **02.06.2010**

(51) Int Cl.:
A61B 17/12 ^(2006.01) **A61M 25/10** ^(2013.01)

(86) International application number:
PCT/IL2010/000436

(87) International publication number:
WO 2010/140150 (09.12.2010 Gazette 2010/49)

(54) **ARTERIAL DEVICE**
ARTERIENVORRICHTUNG
DISPOSITIF ARTÉRIEL

(84) Designated Contracting States:
AL AT BE BG CH CY CZ DE DK EE ES FI FR GB GR HR HU IE IS IT LI LT LU LV MC MK MT NL NO PL PT RO SE SI SK SM TR

(30) Priority: **04.06.2009 US 184019 P**

(43) Date of publication of application:
11.04.2012 Bulletin 2012/15

(73) Proprietor: **Cardiogard Medical Ltd.**
Or-Yehuda 6037604 (IL)

(72) Inventors:
• **TAUB, Eldad**
71908 Reut (IL)

• **SELA, Nathan**
71700 Modiin (IL)
• **DILMONEY, Benjamin**
54422 Givat Shmuel (IL)

(74) Representative: **Szabo, Zsolt**
Danubia
Patent & Law Office LLC
Bajcsy-Zsilinszky út 16
1051 Budapest (HU)

(56) References cited:
WO-A1-2005/123158 US-A- 4 134 402
US-A- 5 584 803 US-A1- 2002 111 583
US-A1- 2002 138 031 US-A1- 2003 221 561

EP 2 437 671 B1

Note: Within nine months of the publication of the mention of the grant of the European patent in the European Patent Bulletin, any person may give notice to the European Patent Office of opposition to that patent, in accordance with the Implementing Regulations. Notice of opposition shall not be deemed to have been filed until the opposition fee has been paid. (Art. 99(1) European Patent Convention).

Description**FIELD OF THE INVENTION**

[0001] This invention relates to arterial devices, systems and methods, particularly associated with performing cardiopulmonary bypass or the like, and/or associated with the removal of embolic debris see US 2003/0221561.

BACKGROUND OF THE INVENTION

[0002] It is known that patients undergoing cardiopulmonary bypass (CPB) during cardiac surgery (usually open heart surgery (in which the heart is opened with a cutting instrument), but sometimes also closed heart surgery (in which the heart is not opened with a cutting instrument)) run a risk of neurologic and neuropsychologic deficit, which are thought to be caused or exacerbated by some types of embolic debris that are known to be released into the aortic arch during cardiac surgery or CPB and are introduced into the cerebral circulation.

[0003] Various devices, systems and methods are known for use in CPB. For example, US 6,689,149 discloses a balloon occlusion device for aspirating embolic material from a blood vessel, such as from the aorta during cardiac surgery. The device includes an arterial cannula having a proximal end adapted to receive blood from a bypass-oxygenator machine, a distal end adapted to enter an artery, and a blood flow lumen extending between the proximal end and an outlet on the distal end. The cannula has an aspiration port proximate to the outlet, which communicates with an aspiration lumen. The cannula also includes an inflatable balloon attached to the cannula between the outlet and the aspiration port and capable of assuming an inflated condition for occluding a blood vessel. To use the device, the distal end of the cannula is introduced into a blood vessel, such as the aorta, the outlet is oriented downstream for delivering blood, and the balloon is inflated to occlude the vessel. In operation, fluid may then be flushed into and aspirated out through the aspiration port to remove loose embolic material from the vessel upstream of the balloon. Optionally, the device may include a second deployable balloon for further occluding the vessel at a second location.

[0004] US 6,726,651 discloses methods, systems and devices for performing cardiopulmonary bypass (CPB), cardioplegic arrest, suction of fluid from the aorta to remove embolic or other fluid from the general circulation and the selective segmentation of the arterial system to perform differential perfusion eliminating hypoperfusion. An aortic catheter having an arch lumen which extends at least in part along the length of the catheter shaft has a proximal opening coupled to a CPB machine and a distal arch opening. A corporeal lumen extends at least in part along the length of the catheter shaft and has a proximal opening coupled to a CPB machine and a distal corporeal opening. A suction lumen extends at least in

part along the length of the catheter shaft and has a proximal suction opening coupled to a suction source and a distal suction opening residing in the aortic lumen of a patient.

[0005] US 5,697,905 discloses a method and apparatus used during cardiac surgery for reducing release of embolized air and particulate matter into general body circulatory system are disclosed. The method uses a catheter apparatus having an inflation lumen, an occlusive balloon, a suction lumen and a perfusion lumen. The catheter is inserted or navigated to into an aortic root and positioned so a suction opening communicates upstream of the aortic root and a perfusion opening communicates downstream of the suction opening. The patient's heart is stopped and the occlusive balloon is inflated to occlude the aorta. Cardiac surgery is performed and when the patient's heart is restarted the blood pumped by the heart during its first few contractions is suctioned through the suction opening.

[0006] US 7,470,363 discloses a number of ultrasonic devices for preventing microbubbles and/or microparticles from reaching the brain during a percutaneous cardiological intervention (PCI) or cardiac surgery.

[0007] US 5,425,724 discloses an aortic cannula having one tube for blood perfusion, and another tube for monitoring arterial pressure.

SUMMARY OF THE INVENTION

[0008] Embolic debris herein refers to any emboli or particles, including for example microparticles or microbubbles, that may be released as a result of the use of an artificial heart-lung machine (bypass-oxygenator machine), and/or due to clamping and/or manipulation of the aorta or the heart during CPB, for example. Embolic debris herein refers also to air bubbles, for example, as may exist in the heart ventricles prior to unclamping, and which are often released to the aorta after unclamping.

[0009] According to a first aspect of the invention there is provided an arterial system, comprising an arterial flow exchange system and a controller, for use with a patient having an aorta and a body blood circulation system, wherein:

said arterial flow exchange system comprises a distal portion arrangement configured for being accommodated in the aorta of the patient in use of the arterial flow exchange system, said distal portion arrangement comprising:

a perfusion lumen arrangement having at least one perfusion outlet and connectable to at least one perfusion source, said perfusion lumen arrangement being configured for providing there-through a target perfusion flow into the aorta (via said at least one perfusion outlet) having a target perfusion flow rate that is greater than a nominal perfusion flow rate by an excess perfusion flow

rate, wherein said nominal perfusion flow is sufficient for providing adequate fluid flow to the body blood circulation system of the patient; and

a suction lumen arrangement having at least one suction inlet and connectable to a suction source, said suction lumen arrangement being configured for providing a suction flow out of the aorta (via said at least one suction inlet), said suction flow having a suction flow rate; said distal portion being configured for providing fluid communication between at least one said perfusion outlet and at least one said suction inlet within the aorta via an outside of said distal portion, in use of the arterial system;

said controller being configured, in use of the arterial system, for:

selectively controllably providing a target perfusion flow into the aorta at said target perfusion flow rate; selectively controllably providing a suction flow out of the aorta at said suction flow rate; and selectively controlling said target perfusion flow rate and said suction flow rate concurrently to cause embolic debris that may be present in the aorta to be diverted to said at least one suction inlet.

[0010] The arterial system according to this aspect of the invention may comprise any one of the following features, or more than one of the following features

(A) wherein said controller is configured for selectively controlling said target perfusion flow rate and said suction flow rate to establish a recirculation flow-field between at least one said perfusion outlet and at least one said suction inlet within the aorta to cause the embolic debris that may be present in the aorta to be diverted to the respective at least one said suction inlet.

(B) wherein said controller is configured for selectively matching said suction flow rate with said excess perfusion flow rate according to a desired matching level, defined as a percentage of said suction flow rate with respect to said excess perfusion flow rate. For example, said matching level may be about 100%, or may be greater than 100%. For example, said matching level may be in a range between about 50% and about 100%.

(C) wherein said target perfusion flow rate is a first proportion of said nominal perfusion flow rate, wherein said first proportion is not less than about 110% of said nominal perfusion flow rate. For example, said first proportion may be between about 110%

and about 150% of said nominal perfusion flow rate, or, for example, said first proportion may be between about 115% and about 160% of said nominal perfusion flow rate, or, for example, said first proportion may be between about 120% and about 150% of said nominal perfusion flow rate, or, for example, said first proportion may be between about 120% and about 170% of said nominal perfusion flow rate.

(D) wherein said suction flow rate is a second proportion of a said nominal perfusion flow rate, wherein said second proportion is not less than about 10% of said nominal perfusion flow rate. For example, said second proportion may be between about 10% and about 50% of said nominal perfusion flow rate, or, for example, said second proportion may be between about 15% and about 60% of said nominal perfusion flow rate, or, for example, said second proportion may be between about 20% and about 50% of said nominal perfusion flow rate, or, for example, said second proportion may be between about 20% and about 70% of said nominal perfusion flow rate.

(E) wherein said arterial flow exchange system is configured for operating in the aorta to provide said excess perfusion flow rate and to provide said suction flow rate in the absence of establishing occlusion of the aorta at least in a region of the aorta corresponding to a part of the arterial flow exchange system extending between said at least one suction inlet and said at least one perfusion outlet.

(F) wherein said device has an absence of an occlusion arrangement that is otherwise configured for providing occlusion of the aorta in operation of said system, at least between said at least one suction inlet and said at least one perfusion outlet.

(G) wherein said arterial system is configured for providing at least one said suction inlet within the ascending aorta of the patient in operation of the arterial system.

(H) wherein said arterial flow exchange system is configured in operation of the arterial system for causing at least a majority of embolic debris that may be present in the aorta to be diverted to said at least one suction inlet at least from upstream of said at least one suction inlet.

(I) wherein said controller is configured for providing said target perfusion flow rate wherein a corresponding target perfusion flow velocity is below a threshold value for avoiding or minimizing damage to blood cells, and/or, wherein said controller is configured for providing said suction flow rate at a corresponding suction flow velocity that is below a threshold value for avoiding or minimizing damage to blood

cells; and/or wherein said perfusion lumen arrangement is configured for providing said target perfusion flow rate wherein a corresponding target perfusion flow velocity is below a threshold value for avoiding or minimizing damage to blood cells, and/or, wherein said suction lumen arrangement is configured for providing said suction flow rate at a corresponding suction flow velocity that is below a threshold value for avoiding or minimizing damage to blood cells.

(J) wherein said distal portion arrangement comprises at least one additional suction outlet port configured for de-airing the aorta by facilitating removing of said embolic debris in the form of air bubbles.

[0011] In at least a first form of the arterial system according to the first aspect of the invention, said arterial flow exchange system (as defined above, optionally comprising any one of features (A) to (J), or more than one of features (A) to (J)), may be embodied (in particular, may be integrally embodied) in an arterial device, and said distal portion arrangement constitutes a distal portion of said arterial device and is configured for being accommodated into the aorta.

[0012] In at least some embodiments according to the said first form of the arterial system, said arterial device is in the form of an aortic cannula, wherein said distal portion is configured for being introduced into the aorta via a wall of the ascending aorta. In at least one such embodiment, said distal portion comprises a curved portion and a distal end, wherein said distal end comprises said at least one perfusion outlet, and wherein said curved portion comprises said at least one suction inlet. In operation said at least one perfusion outlet is facing in a generally downstream direction along the aorta and said at least one suction inlet is facing in a generally upstream direction along the aorta. Optionally, said perfusion lumen arrangement comprises a first lumen, wherein said suction lumen arrangement comprises a second lumen, and wherein said first lumen and said second lumen are integrally formed in said distal portion. The first lumen may have a first flow cross-section and said second lumen may have a second flow cross-section, wherein a cross section ratio between said first flow cross-section and said second flow cross-section is not less than about 1.10. For example, said cross section ratio may be between about 1.10 and about 10.0. In at least some embodiments, said distal portion comprises one said perfusion outlet and one said suction inlet.

[0013] In at least some other embodiments according to the said first form of the arterial system, said arterial device is in the form of an aortic catheter, wherein said distal portion is configured for being introduced into the aorta via an entry point at a location downstream of the descending aorta, the distal portion being further configured for being navigated upstream to the ascending aorta. In at least one such embodiment, said distal portion comprises a distal end and an elongate portion extending

proximally from said distal end, wherein said distal end comprises said at least one perfusion outlet, and wherein said elongate portion comprises said at least one suction inlet. In operation said at least one perfusion outlet is downstream of said at least one suction inlet with respect to antegrade flow in the aorta. In operation, said at least one suction inlet is facing in a generally upstream direction along the aorta in operation of the arterial system. Optionally, said perfusion lumen arrangement comprises a first lumen and said suction lumen arrangement comprises a second lumen, and wherein said first lumen and said second lumen are integrally formed coaxially in said distal portion. Said first lumen may have a first flow cross-section and said second lumen may have a second flow cross-section, wherein a cross section ratio between said first flow cross-section and said second flow cross-section is not less than about 1.10. For example, said cross section ratio is between about 1.10 and about 10. In some such embodiments, said distal portion comprises a plurality of said perfusion outlets and one said suction inlet; in other such embodiments, said distal portion comprises a plurality of said perfusion outlets and a plurality of said suction inlets; optionally in either case, said plurality of perfusion outlet ports may comprise at least a first group of said perfusion outlet ports and a second group of said perfusion outlet ports, wherein said second group is located proximally of said first group, and wherein said first group is located within the ascending aorta or aortic arch in operation of the arterial system.

[0014] In at least a second form of the arterial system, said arterial flow exchange system (as defined above, optionally comprising any one of features (A) to (J), or more than one of features (A) to (J)), comprises a first arterial device and a second arterial device separate from said first arterial device, and said distal portion arrangement comprises a distal portion of said first arterial device and a distal portion of said second device, wherein said first arterial device and said second arterial device are configured for being independently accommodated into the aorta, wherein said perfusion lumen arrangement comprises at least a first perfusion lumen comprised in said first arterial device, and at least one second perfusion lumen comprised in said second arterial device, and wherein said suction lumen arrangement comprises at least one suction lumen comprised in said second arterial device.

[0015] In at least some embodiments following said second form of the arterial system said first arterial device is configured for providing said nominal perfusion flow rate via said at least one first perfusion lumen and at least one respective said perfusion outlet comprised in said first arterial device, wherein said second arterial device is configured for providing said excess perfusion flow rate via said at least one second perfusion lumen and at least one respective said perfusion outlet comprised in said second arterial device, and wherein said second arterial device is further configured to provide said suction flow rate via said suction lumen and at least one said suction

inlet comprised in said second arterial device. In at least some such embodiments, said second arterial device is in the form of an aortic cannula, wherein said second distal portion is configured for being introduced into the aorta via a wall of the ascending aorta. Additionally or alternatively, (i) said first arterial device is in the form of an aortic cannula, wherein said first distal portion is configured for being introduced into the aorta via a wall of the aorta proximal to said second arterial device, or (ii) said first arterial device is in the form of an aortic catheter, wherein said first distal portion is configured for being introduced into the aorta via an entry point at a location downstream of the descending aorta, the first distal portion being further configured for being navigated upstream to the ascending aorta to a position proximal to said second arterial device.

[0016] According to the first aspect of the invention, the arterial system, as defined above, optionally comprising any one of features (A) to (J), or more than one of features (A) to (J), and/or according to the aforementioned first form of the arterial system or according to the aforementioned second form of the arterial system, may be further configured according to any one of the following features, or according to more than one of the following features in any combination or permutation:

(K) wherein said nominal perfusion flow rate is in the range between about 3 liters per minute to about 5 liters per minute;

(L) wherein said target flow rate is in the range between about 3.3 liters per minute to about 7.5 liters per minute;

(M) wherein said excess perfusion flow rate is in the range between about 0.3 liters per minute to about 2.5 liters per minute;

(N) wherein said suction flow rate is greater than 0.5 liters per minute;

(O) wherein said suction flow rate is greater than 0.75 liters per minute; wherein said suction flow rate is greater than 1 liter per minute;

(P) wherein said suction flow rate is greater than 1.25 liters per minute;

(Q) wherein said suction flow rate is in the range between about 0.5 liters per minute to about 2.0 liters per minute;

(R) wherein said suction flow rate is in the range between about 0.5 liters per minute to about 2.5 liters per minute;

(S) wherein said suction flow rate is in the range between about 0.75 liters per minute to about 2.5 liters

per minute.

[0017] In operation of the arterial system according to the first aspect of the invention, said perfusion lumen arrangement is connected to said at least one perfusion source, and said suction lumen arrangement is connected to said suction source.

[0018] There is also provided an arterial device, for use with a patient having an aorta and a body blood circulation system, the arterial device comprising a distal portion arrangement configured for being accommodated in the aorta of the patient in use of the arterial device, said distal portion arrangement comprising:

a perfusion lumen arrangement having at least one perfusion outlet and connectable to at least one perfusion source, said perfusion lumen arrangement being configured for providing therethrough a target perfusion flow into the aorta (via said at least one perfusion outlet) having a target perfusion flow rate that is greater than a nominal perfusion flow rate by an excess perfusion flow rate, wherein said nominal perfusion flow is sufficient for providing adequate fluid flow to the body blood circulation system of the patient;

and
a suction lumen arrangement having at least one suction inlet and connectable to a suction source, said suction lumen arrangement being configured for providing a suction flow out of the aorta (via said at least one suction inlet), said suction flow having a suction flow rate;
said distal portion being configured for providing fluid communication between at least one said perfusion outlet and at least one said suction inlet within the aorta via an outside of said distal portion, in use of the arterial device;
wherein the arterial device is configured for enabling said target perfusion flow rate and said suction flow rate to be concurrently and selectively controlled to cause embolic debris that may be present in the aorta to be diverted to said at least one suction inlet.

[0019] The arterial device according to this aspect and as defined above may comprise any one of the following features, or more than one of the following features:

(A1) wherein said arterial device is configured for enabling selectively matching said suction flow rate with said excess perfusion flow rate according to a desired matching level, defined as a percentage of said suction flow rate with respect to said excess perfusion flow rate. For example, said matching level may be about 100%, or may be greater than 100%. For example, said matching level may be in a range between about 50% and about 100%.

(B1) wherein said target perfusion flow rate is a first proportion of said nominal perfusion flow rate,

wherein said first proportion is not less than about 110% of said nominal perfusion flow rate. For example, said first proportion may be between about 110% and about 150% of said nominal perfusion flow rate, or, for example, said first proportion may be between about 115% and about 160% of said nominal perfusion flow rate, or, for example, said first proportion may be between about 120% and about 150% of said nominal perfusion flow rate, or, for example, said first proportion may be between about 120% and about 170% of said nominal perfusion flow rate. (C1) wherein said suction flow rate is a second proportion of a said nominal perfusion flow rate, wherein said second proportion is not less than about 10% of said nominal perfusion flow rate. For example, said second proportion may be between about 10% and about 50% of said nominal perfusion flow rate, or, for example, said second proportion may be between about 15% and about 60% of said nominal perfusion flow rate, or, for example, said second proportion may be between about 20% and about 50% of said nominal perfusion flow rate, or, for example, said second proportion may be between about 20% and about 70% of said nominal perfusion flow rate. (D1) wherein said arterial device is configured for operating in the aorta to provide said excess perfusion flow rate and to provide said suction flow rate in the absence of establishing occlusion of the aorta at least in a region of the aorta corresponding to a part of the arterial device extending between said at least one suction inlet and said at least one perfusion outlet.

(E1) wherein said device having an absence of an occlusion arrangement that is otherwise configured for providing occlusion of the aorta in operation of said arterial device, at least between said at least one suction inlet and said at least one perfusion outlet.

(F1) wherein said arterial device is configured for providing at least one said suction inlet within the ascending aorta of the patient in operation of the arterial device.

(G1) wherein said flow exchange arterial device is configured in operation of the arterial device for causing at least a majority of embolic debris that may be present in the aorta to be diverted to said at least one suction inlet at least from upstream of said at least one suction inlet.

(H1) wherein said arterial device is configured for providing said target perfusion flow rate wherein a corresponding target perfusion flow velocity is below a threshold value for avoiding or minimizing damage to blood cells, and/or wherein said arterial device is configured for providing said suction flow rate at a corresponding suction flow velocity that is below a threshold value for avoiding or minimizing damage to blood cells; and/or wherein said perfusion lumen arrangement is configured for providing said target

perfusion flow rate wherein a corresponding target perfusion flow velocity is below a threshold value for avoiding or minimizing damage to blood cells, and/or, wherein said suction lumen arrangement is configured for providing said suction flow rate at a corresponding suction flow velocity that is below a threshold value for avoiding or minimizing damage to blood cells.

(I1) wherein said distal portion arrangement comprises at least one additional suction outlet port configured for de-airing the aorta by facilitating removing of said embolic debris in the form of air bubbles.

[0020] In at least a first group of embodiments, said arterial device as defined above, optionally comprising any one of features (A1) to (I1), or more than one of features (A1) to (I1), is in the form of an aortic cannula, wherein said distal portion is configured for being introduced into the aorta via a wall of the ascending aorta. In at least one such embodiment of said first group, said distal portion comprises a curved portion and a distal end, wherein said distal end comprises said at least one perfusion outlet, and wherein said curved portion comprises said at least one suction inlet. In operation said at least one perfusion outlet is facing in a generally downstream direction along the aorta and said at least one suction inlet is facing in a generally upstream direction along the aorta. Additionally or alternatively, said perfusion lumen arrangement comprises a first lumen, wherein said suction lumen arrangement comprises a second lumen, and wherein said first lumen and said second lumen are integrally formed in said distal portion. The first lumen may have a first flow cross-section and said second lumen may have a second flow cross-section, wherein a cross section ratio between said first flow cross-section and said second flow cross-section is not less than about 1.10. For example, said cross section ratio is between about 1.10 and about 10.0. In at least some such embodiments of said first group, said distal portion comprises one said perfusion outlet and one said suction inlet.

[0021] In at least a second group of embodiments, said arterial device as defined above, optionally comprising any one of features (A1) to (I1), or more than one of features (A1) to (I1), is in the form of an aortic catheter, wherein said distal portion is configured for being introduced into the aorta via an entry point at a location downstream of the descending aorta, the distal portion being further configured for being navigated upstream to the ascending aorta. In at least some such embodiments of said second group, said distal portion comprises a distal end and an elongate portion extending proximally from said distal end, wherein said distal end comprises said at least one perfusion outlet, and wherein said elongate portion comprises said at least one suction inlet. In operation said at least one perfusion outlet is downstream of said at least one suction inlet with respect to antegrade flow in the aorta. In at least some such embodiments of

said second group of embodiments, said at least one suction inlet is facing in a generally upstream direction along the aorta in operation of the arterial device. Optionally, said perfusion lumen arrangement comprises a first lumen and said suction lumen arrangement comprises a second lumen, and wherein said first lumen and said second lumen are integrally formed coaxially in said distal portion. Said first lumen may have a first flow cross-section and said second lumen may have a second flow cross-section, wherein a cross section ratio between said first flow cross-section and said second flow cross-section is not less than about 1.10. For example, said cross section ratio is between about 1.10 and about 10. In some such embodiments, said distal portion comprises a plurality of said perfusion outlets and one said suction inlet; in other such embodiments, said distal portion comprises a plurality of said perfusion outlets and a plurality of said suction inlets; optionally in either case, said plurality of perfusion outlet ports comprises at least a first group of said perfusion outlet ports and a second group of said perfusion outlet ports, wherein said second group of said perfusion outlet ports is located proximally of said first group of said perfusion outlet ports, and wherein said first group of said perfusion outlet ports is located within the ascending aorta or aortic arch in operation of the arterial device.

[0022] The arterial device, as defined above, optionally comprising any one of features (A1) to (I1), or more than one of features (A1) to (I1), and/or according to the aforementioned first group of embodiments of the arterial device or according to the aforementioned second group of embodiments of the arterial device, may be further configured according to any one of the following features, or according to more than one of the following features:

(J1) wherein said nominal perfusion flow rate is in the range between about 3 liters per minute to about 5 liters per minute;

(K1) wherein said target flow rate is in the range between about 3.3 liters per minute to about 7.5 liters per minute;

(L1) wherein said excess perfusion flow rate is in the range between about 0.3 liters per minute to about 2.5 liters per minute;

(M1) wherein said suction flow rate is greater than 0.5 liters per minute;

(N1) wherein said suction flow rate is greater than 0.75 liters per minute; wherein said suction flow rate is greater than 1 liter per minute;

(O1) wherein said suction flow rate is greater than 1.25 liters per minute;

(P1) wherein said suction flow rate is in the range

between about 0.5 liters per minute to about 2.0 liters per minute;

(Q1) wherein said suction flow rate is in the range between about 0.5 liters per minute to about 2.5 liters per minute;

(R1) wherein said suction flow rate is in the range between about 0.75 liters per minute to about 2.5 liters per minute.

[0023] There is also provided a method for removing embolic debris from an aorta of a patient having a body blood circulation system, comprising:

(a) providing an arterial flow exchange system comprising a distal portion arrangement configured for being accommodated in the aorta of the patient in use of the arterial flow exchange system, said distal portion arrangement comprising:

a perfusion lumen arrangement having at least one perfusion outlet and connectable to at least one perfusion source, said perfusion lumen arrangement being configured for providing there-through a target perfusion flow into the aorta having a target perfusion flow rate that is greater than a nominal perfusion flow rate by an excess perfusion flow rate, wherein said nominal perfusion flow is sufficient for providing adequate fluid flow to the body blood circulation system of the patient;

and
a suction lumen arrangement having at least one suction inlet and connectable to a suction source, said suction lumen arrangement being configured for providing a suction flow out of the aorta, said suction flow having a suction flow rate;

said distal portion being configured for providing fluid communication between at least one said perfusion outlet and at least one said suction inlet within the aorta via an outside of said distal portion, in use of the arterial flow exchange system;

(b) accommodating said distal portion arrangement in the aorta of the patient so that at least one said suction inlet port is accommodated in the ascending aorta of the patient;

(c) controllably providing a target perfusion flow into the aorta at said target perfusion flow rate;

(d) controllably providing a suction flow out of the aorta at said suction flow rate; and

(e) selectively controlling said target perfusion flow rate and said suction flow rate to cause embolic debris that may be present in the aorta to be diverted to said at least one suction inlet.

[0024] Optionally, step (e) comprises selectively controlling said target perfusion flow rate and said suction flow rate to establish a recirculation flowfield between at least one said perfusion outlet and at least one said suction inlet within the aorta to cause the embolic debris that may be present in the aorta to be diverted to the respective at least one said suction inlet.

[0025] Additionally or alternatively, step (b) comprises accommodating said distal portion arrangement in the aorta of the patient so that at least one said perfusion outlet port is accommodated in the ascending aorta of the patient.

[0026] Additionally or alternatively, step (b) comprises accommodating said distal portion arrangement in the aorta of the patient so that at least one said perfusion outlet port is accommodated in the aortic arch of the patient.

[0027] Additionally or alternatively, step (e) comprises selectively matching said suction flow rate with said excess perfusion flow rate according to a desired matching level, defined as a percentage of said suction flow rate with respect to said excess perfusion flow rate. For example, said matching level is about 100%, or above 100%. For example, said matching level is between about 50% and about 100%.

[0028] Additionally or alternatively, said target perfusion flow rate is a first proportion of said nominal perfusion flow rate, wherein said first proportion is not less than about 110% of said nominal perfusion flow rate.

[0029] Additionally or alternatively, said target perfusion flow rate is a first proportion of said nominal perfusion flow rate, wherein said first proportion is not less than about 110% of said nominal perfusion flow rate. For example, said first proportion may be between about 110% and about 150% of said nominal perfusion flow rate, or, for example, said first proportion may be between about 115% and about 160% of said nominal perfusion flow rate, or, for example, said first proportion may be between about 120% and about 150% of said nominal perfusion flow rate, or, for example, said first proportion may be between about 120% and about 170% of said nominal perfusion flow rate.

[0030] Additionally or alternatively, said suction flow rate is a second proportion of a said nominal perfusion flow rate, wherein said second proportion is not less than about 10% of said nominal perfusion flow rate. For example, said second proportion may be between about 10% and about 50% of said nominal perfusion flow rate, or, for example, said second proportion may be between about 15% and about 60% of said nominal perfusion flow rate, or, for example, said second proportion may be between about 20% and about 50% of said nominal perfusion flow rate, or, for example, said second proportion may be between about 20% and about 70% of said nominal perfusion flow rate.

[0031] Additionally or alternatively, said, at least steps (b) to (e) are conducted in the absence of establishing occlusion of the aorta at least in a region of the aorta

corresponding to a part of the device extending between said at least one suction inlet and said at least one perfusion outlet.

[0032] Additionally or alternatively, said device has an absence of an occlusion arrangement that is otherwise configured for providing occlusion of the aorta in operation of said device, at least between said at least one suction inlet and said at least one perfusion outlet.

[0033] Additionally or alternatively, in step (e) at least a majority of embolic debris that may be present in the aorta are caused to be diverted to said at least one suction inlet at least from upstream of said at least one suction inlet.

[0034] Additionally or alternatively, said target perfusion flow rate is provided having a corresponding target perfusion flow velocity that is below a threshold value for avoiding or minimizing damage to blood cells, and/or said suction flow rate is provided at a corresponding suction flow velocity that is below a threshold value for avoiding or minimizing damage to blood cells.

[0035] Additionally or alternatively, said distal portion arrangement comprises at least one additional suction outlet port configured for de-airing the aorta, and further comprising the step of removing said embolic debris in the form of air bubbles.

[0036] In at least a first form of carrying out the method, said arterial flow exchange system is embodied in an arterial device, and said distal portion arrangement constitutes a distal portion of said arterial device and configured for being accommodated into the aorta.

[0037] For example, said arterial device is in the form of an aortic cannula, and in step (b) said distal portion is introduced into the aorta via a wall of the ascending aorta.

[0038] Alternatively, said arterial device is in the form of an aortic catheter, and in step (b) said distal portion is introduced into the aorta via an entry point at a location downstream of the descending aorta, and said distal portion is navigated upstream to the ascending aorta. For example, said entry point is provided in a femoral artery or an iliac artery of the patient.

[0039] Additionally or alternatively, said perfusion lumen arrangement comprises a perfusion lumen having a first flow cross-section, and said suction lumen arrangement comprises a suction lumen having a second flow cross-section, wherein a cross section ratio between said first flow cross-section and said second flow cross-section is not less than about 1.10. For example, said cross section ratio is between about 1.10 and about 1.5.

[0040] In at least a second form of carrying out the method, said arterial flow exchange system comprises a first arterial device and a second arterial device separate from said first arterial device, and said distal portion arrangement comprises a distal portion of said first arterial device and a distal portion of said second device, wherein said first arterial device and said second arterial device are independently accommodated into the aorta, wherein said perfusion lumen arrangement comprises at least a first perfusion lumen comprised in said first arterial de-

vice, and at least one second perfusion lumen comprised in said second arterial device, and wherein said suction lumen arrangement comprises at least one suction lumen comprised in said second arterial device. For example, said first arterial device is operated to provide said nominal perfusion flow rate via said at least one first perfusion lumen and at least one respective said perfusion outlet comprised in said first arterial device, wherein said second arterial device is operated to provide said excess perfusion flow rate via said at least one second perfusion lumen and at least one respective said perfusion outlet comprised in said second arterial device, and wherein said second arterial device is further operated to provide said suction flow rate via said suction lumen and at least one said suction inlet comprised in said second arterial device.

[0041] The method for removing embolic debris from an aorta of a patient having a body blood circulation system, may further comprise one or more of the following features:

- wherein said nominal perfusion flow rate is provided in the range between about 3 liters per minute to about 5 liters per minute;
- wherein said target flow rate is provided in the range between about 3.3 liters per minute to about 7.5 liters per minute;
- wherein said excess perfusion flow rate is provided in the range between about 0.3 liters per minute to about 2.5 liters per minute;
- wherein said suction flow rate is greater than 0.5 liters per minute; r
- wherein said suction flow rate is greater than 0.75 liters per minute; wherein said suction flow rate is greater than 1 liter per minute;
- wherein said suction flow rate is greater than 1.25 liters per minute;
- wherein said suction flow rate is in the range between about 0.5 liters per minute to about 2.0 liters per minute;
- wherein said suction flow rate is in the range between about 0.5 liters per minute to about 2.5 liters per minute;
- wherein said suction flow rate is in the range between about 0.75 liters per minute to about 2.5 liters per minute.

[0042] According to a second aspect of the disclosure there is provided an arterial device, for use with a patient having an aorta and a body blood circulation system, the

arterial device comprising a distal portion arrangement configured for being accommodated in the aorta of the patient in use of the system, said distal portion arrangement comprising:

a perfusion lumen arrangement having at least one perfusion outlet and connectable to at least one perfusion source, wherein said perfusion lumen arrangement is configured for providing therethrough a perfusion flow into the aorta (via said at least one perfusion outlet), said perfusion flow having a perfusion flow rate;

and
a suction lumen arrangement having at least one suction inlet and connectable to a suction source, said suction lumen arrangement being configured for providing a suction flow out of the aorta (via said at least one suction inlet), said suction flow having a suction flow rate;

wherein said suction flow rate is greater than 0.5 liters per minute.

[0043] The arterial device according to the second aspect may comprise any one of the following features (a2) to (d2), or more than one of the following features (a2) to (d2):

(a2) wherein said suction lumen arrangement is configured for providing said suction flow rate at a corresponding suction flow velocity that is below a threshold value for avoiding or minimizing damage to blood cells.

(b2) wherein said perfusion flow rate comprises a target perfusion flow rate that is greater than a nominal perfusion flow rate by an excess perfusion flow rate, wherein said nominal perfusion flow is sufficient for providing adequate fluid flow to the body blood circulation system of the patient.

(c2) wherein said distal portion is configured for providing fluid communication between at least one said perfusion outlet and at least one said suction inlet within the aorta via an outside of said distal portion, in use of the arterial device.

(d2) wherein said distal portion is configured for providing fluid communication between at least one said perfusion outlet and at least one said suction inlet within the aorta via an outside of said distal portion, in use of the arterial device.

[0044] Furthermore, the arterial device according to the second aspect may comprise any one of the following features (A2) to (I2), or more than one of the following features (A2) to (I2):

(A2) wherein said arterial device is configured for

enabling selectively matching said suction flow rate with said excess perfusion flow rate according to a desired matching level, defined as a percentage of said suction flow rate with respect to said excess perfusion flow rate. For example, said matching level may be about 100%, or may be greater than 100%. For example, said matching level may be in a range between about 50% and about 100%.

(B2) wherein said target perfusion flow rate is a first proportion of said nominal perfusion flow rate, wherein said first proportion is not less than about 110% of said nominal perfusion flow rate. For example, said first proportion may be between about 110% and about 150% of said nominal perfusion flow rate, or, for example, said first proportion may be between about 115% and about 160% of said nominal perfusion flow rate, or, for example, said first proportion may be between about 120% and about 150% of said nominal perfusion flow rate, or, for example, said first proportion may be between about 120% and about 170% of said nominal perfusion flow rate.

(C2) wherein said suction flow rate is a second proportion of a said nominal perfusion flow rate, wherein said second proportion is not less than about 10% of said nominal perfusion flow rate. For example, said second proportion may be between about 10% and about 50% of said nominal perfusion flow rate, or, for example, said second proportion may be between about 15% and about 60% of said nominal perfusion flow rate, or, for example, said second proportion may be between about 20% and about 50% of said nominal perfusion flow rate, or, for example, said second proportion may be between about 20% and about 70% of said nominal perfusion flow rate.

(D2) wherein said arterial device is configured for operating in the aorta to provide said excess perfusion flow rate and to provide said suction flow rate in the absence of establishing occlusion of the aorta at least in a region of the aorta corresponding to a part of the arterial device extending between said at least one suction inlet and said at least one perfusion outlet.

(E2) wherein said device having an absence of an occlusion arrangement that is otherwise configured for providing occlusion of the aorta in operation of said arterial device, at least between said at least one suction inlet and said at least one perfusion outlet.

(F2) wherein said arterial device is configured for providing at least one said suction inlet within the ascending aorta of the patient in operation of the arterial device.

(G2) wherein said flow exchange arterial device is configured in operation of the arterial device for causing at least a majority of embolic debris that may be present in the aorta to be diverted to said at least one suction inlet at least from upstream of said at least one suction inlet.

(H2) wherein said arterial device is configured for providing said target perfusion flow rate wherein a corresponding target perfusion flow velocity is below a threshold value for avoiding or minimizing damage to blood cells.

(I2) wherein said distal portion arrangement comprises at least one additional suction outlet port configured for de-airing the aorta by facilitating removing of said embolic debris in the form of air bubbles.

[0045] In at least a first group of embodiments according to the second aspect, said arterial device, optionally comprising any one of features (a2) to (d2) or (A2) to (I2), or more than one of features (a2) to (d2) and/or (A2) to (I2), is in the form of an aortic cannula, wherein said distal portion is configured for being introduced into the aorta via a wall of the ascending aorta. In at least one such embodiment of said first group, said distal portion comprises a curved portion and a distal end, wherein said distal end comprises said at least one perfusion outlet, and wherein said curved portion comprises said at least one suction inlet. In operation said at least one perfusion outlet is facing in a generally downstream direction along the aorta and said at least one suction inlet is facing in a generally upstream direction along the aorta. Additionally or alternatively, said perfusion lumen arrangement comprises a first lumen, wherein said suction lumen arrangement comprises a second lumen, and wherein said first lumen and said second lumen are integrally formed in said distal portion. The first lumen may have a first flow cross-section and said second lumen may have a second flow cross-section, wherein a cross section ratio between said first flow cross-section and said second flow cross-section is not less than about 1.10. For example, said cross section ratio is between about 1.10 and about 10.0. In at least some such embodiments of said first group, said distal portion comprises one said perfusion outlet and one said suction inlet.

[0046] In at least a second group of embodiments according to the second aspect, said arterial device, optionally comprising any one of features (a2) to (d2) or (A2) to (I2), or more than one of features (a2) to (d2) and/or (A2) to (I2), is in the form of an aortic catheter, wherein said distal portion is configured for being introduced into the aorta via an entry point at a location downstream of the descending aorta, the distal portion being further configured for being navigated upstream to the ascending aorta. In at least some such embodiments of said second group, said distal portion comprises a distal end and an elongate portion extending proximally from

said distal end, wherein said distal end comprises said at least one perfusion outlet, and wherein said elongate portion comprises said at least one suction inlet. In operation said at least one perfusion outlet is downstream of said at least one suction inlet with respect to antegrade flow in the aorta. In at least some such embodiments of said second group of embodiments, said at least one suction inlet is facing in a generally upstream direction along the aorta in operation of the arterial device. Optionally, said perfusion lumen arrangement comprises a first lumen and said suction lumen arrangement comprises a second lumen, and wherein said first lumen and said second lumen are integrally formed coaxially in said distal portion. Said first lumen may have a first flow cross-section and said second lumen may have a second flow cross-section, wherein a cross section ratio between said first flow cross-section and said second flow cross-section is not less than about 1.10. For example, said cross section ratio is between about 1.10 and about 10. In some such embodiments, said distal portion comprises a plurality of said perfusion outlets and one said suction inlet; in other such embodiments, said distal portion comprises a plurality of said perfusion outlets and a plurality of said suction inlets; optionally in either case, said plurality of perfusion outlet ports comprises at least a first group of said perfusion outlet ports and a second group of said perfusion outlet ports, wherein said second group of said perfusion outlet ports is located proximally of said first group of said perfusion outlet ports, and wherein said first group of said perfusion outlet ports is located within the ascending aorta or aortic arch in operation of the arterial device.

[0047] According to the second aspect, the arterial device, as defined above, optionally comprising any one of features (a2) to (d2) and/or (A2) to (I2), or more than one of features (a2) to (d2) and/or (A2) to (I2) , and/or according to the aforementioned first group of embodiments or according to the aforementioned second group of embodiments of the arterial device, may be further configured according to any one of the following features, or according to more than one of the following features:

(J2) wherein said nominal perfusion flow rate is in the range between about 3 liters per minute to about 5 liters per minute;

(K2) wherein said target flow rate is in the range between about 3.3 liters per minute to about 7.5 liters per minute;

(L2) wherein said excess perfusion flow rate is in the range between about 0.3 liters per minute to about 2.5 liters per minute;

(M2) wherein said suction flow rate is greater than 0.75 liters per minute; wherein said suction flow rate is greater than 1 liter per minute;

(N2) wherein said suction flow rate is greater than 1.25 liters per minute;

(O2) wherein said suction flow rate is in the range between about 0.5 liters per minute to about 2.0 liters per minute;

(P2) wherein said suction flow rate is in the range between about 0.5 liters per minute to about 2.5 liters per minute;

(Q2) wherein said suction flow rate is in the range between about 0.75 liters per minute to about 2.5 liters per minute.

[0048] According to the second aspect, there is also provided an arterial system for use with a patient having an aorta and a body blood circulation system, comprising:

an arterial device as defined herein according to the second aspect of the invention;
a controller, configured, in use of the arterial system, for:

selectively controllably providing a target perfusion flow into the aorta at said target perfusion flow rate;

selectively controllably providing a suction flow out of the aorta at said suction flow rate; and
selectively controlling said target perfusion flow rate and said suction flow rate concurrently to cause embolic debris that may be present in the aorta to be diverted to said at least one suction inlet.

[0049] In operation of the arterial system according to the second aspect, said perfusion lumen arrangement is connected to said at least one perfusion source, and said suction lumen arrangement is connected to said suction source.

[0050] According to the second aspect there is also provided a method for removing embolic debris from an aorta of a patient having a body blood circulation system, comprising:

- providing an arterial device according to the second aspect of the invention;

- accommodating a distal portion arrangement of the device in the aorta of the patient so that at least at least one said suction inlet port is accommodated in the ascending aorta of the patient;

- controllably providing a suction flow out of the aorta at said suction flow rate, wherein said suction flow rate is greater than 0.5 liters per minute.

Additionally, the method may also comprise the following

steps:

- controllably providing a target perfusion flow into the aorta at said target perfusion flow rate; and
- selectively controlling said target perfusion flow rate and said suction flow rate to cause embolic debris that may be present in the aorta to be diverted to said at least one suction inlet.

[0051] According to at least some aspects, there is provided an arterial device, system and method are provided for use with a patient undergoing a cardiac procedure. The system is configured for enabling one or more arterial devices to be accommodated in the aorta of the patient in use of the system, and a perfusion lumen arrangement provides therethrough a target perfusion flow into the aorta having a target perfusion flow rate that is significantly greater than a nominal perfusion flow rate, by an excess perfusion flow rate. A suction lumen arrangement provides therethrough a suction flow out of the aorta at a suction flow rate. The target perfusion flow rate and the suction flow rate may be concurrently and selectively controlled to cause embolic debris that may be present in the aorta to be diverted to the suction inlet, while providing the nominal flow rate to the body circulation of the patient.

[0052] Herein, the term "distal" refers to a direction generally towards the inside of the body from an outside thereof, while the term "proximal" refers to a direction generally towards the outside of the body from an inside thereof.

[0053] Herein, "nominal perfusion flow" refers to a perfusion flow that is the minimum sufficient for providing adequate fluid flow to the body blood circulation system of the patient, i.e., a minimum perfusion flow having a corresponding nominal perfusion flow rate that is sufficient to sustain the full metabolic demands of the patient. In practice, a patient may have an actual perfusion flow rate, normally provided by the heart, that can vary within a range, and this range may change according to the respective condition of the patient, and depend on various factors that define this condition, for example including one or more of state of health, body temperature, body activity and so on. Thus, the nominal perfusion flow rate herein refers to the minimum perfusion flow rate of the range of perfusion flow rates for the respective condition of the patient. The nominal perfusion flow rate is in practice conventionally determined by the medical staff carrying out the respective cardiac procedure, and there are a number of standard conventional methods commonly used for determining the nominal perfusion flow rate for a particular patient. For example, one such method is based on body surface area (BSA), and a fixed perfusion flow rate per square meter of body surface of the patient is provided. This fixed perfusion flow rate per square meter of body surface of the patient may be, for example, about 2.4 liters per minute per square meter,

and thus, for example, a patient having a BSA of 1.8 m² would have a nominal perfusion flow rate of about 4.3 liters/min (= 2.4*1.8). In some cases, the fixed perfusion flow rate per square meter of body surface of the patient may be different from 2.4 liters per minute per square meter - for example 2.3 liters per minute per square meter, or 2.5 liters per minute per square meter. Other methods may be used for determining the nominal perfusion flow rate for the patient, for example employing known dynamic calculation that may change the nominal perfusion flow rate during the cardiac procedure.

[0054] The "body blood circulation system" of the patient herein includes the corporeal body circulation system and the cerebral circulation system which are normally supplied by the aorta.

BRIEF DESCRIPTION OF THE DRAWINGS

[0055] In order to understand the invention and to see how it may be carried out in practice, embodiments will now be described, by way of non-limiting example only, with reference to the accompanying drawings, in which:

Fig. 1 is a simplified schematic illustration of the general anatomy of the aorta.

Fig. 2 is a schematic illustration of an aortic system according to a first embodiment of the invention, wherein the respective aortic device is installed in the aorta.

Fig. 3 is a cross-sectional side view of the aortic device of the embodiment of Fig. 2; **Fig. 3a** is a cross-sectional side view of an alternative variation of the embodiment of Fig. 3.

Fig. 4 is a side view of the aortic device of the embodiment of Fig. 3; **Figs 4a to Fig. 4m** are a series of cross-sectional views of the arterial device of the embodiment of Fig. 2, taken along sections 0 to 28, respectively, of Fig. 4; **Fig. 4n** is a top view of the embodiment of Fig. 4; **Fig. 4o** is a transverse cross-section of the embodiment of Fig. 4n taken along A-A.

Fig. 5 illustrates schematically perfusion and suction flows within the aorta using the embodiment of Fig. 1.

Fig. 6 illustrates schematically perfusion and suction flows within the aorta using the embodiment of Fig. 1, where the suction flow rate is below a threshold value.

Fig. 7 illustrates schematically perfusion and suction flows within the aorta using the embodiment of Fig. 1, where the suction flow rate is at or above a threshold value.

Fig. 8 is a cross-sectional side view of an alternative variation of the arterial device of the embodiment of Fig. 2, and schematically illustrates perfusion and suction flows within the aorta using the same.

Fig. 9 is a cross-sectional side view of another alternative variation of the arterial device of the embodiment of Fig. 2, and schematically illustrates per-

fusion and suction flows within the aorta using the same.

Fig. 10 is a schematic illustration of an aortic system according to a second embodiment of the invention, wherein the respective arterial device is installed in the aorta.

Fig. 11 is a cross-sectional side view of the arterial device of the embodiment of Fig. 10.

Fig. 12 is a cross-sectional side view of an alternative variation of the arterial device of the embodiment of Figs. 10 and 11.

Fig. 13 is a schematic illustration of an aortic system according to a third embodiment of the invention, wherein the respective arterial devices are installed in the aorta.

Fig. 14 is a schematic illustration of an aortic system according to a fourth embodiment of the invention, wherein the respective arterial devices are installed in the aorta.

DETAILED DESCRIPTION OF EMBODIMENTS

[0056] By way of general background, Fig. 1 illustrates schematically the anatomy of the aorta **1**, which is the main blood conduit of a series of blood vessels which transport oxygenated blood from the heart to the body tissues of a patient. The aorta is, for ease of reference, divided into the following portions: the ascending aorta **2**, the aortic arch **3**, and the descending aorta **4**. The ascending aorta **2** extends from the upper part of the left ventricle of the heart **9** to the upstream end **3U** of the aortic arch **3**. The aortic arch **3** has three branches - the innominate artery **5** (also referred to as the brachio-cephalic artery), the left common carotid artery **6** and the left subclavian artery **7** - which supply oxygenated blood to the cerebral circulation system. The descending aorta **4** starts at the downstream end **3D** of the aortic arch **3** and supplies oxygenated blood to the corporeal body circulation system. The descending aorta **4** continues through the abdomen and splits into the two common iliac arteries **8** that supply oxygenated blood to the lower extremities of the body.

[0057] Referring to Figs. **2** and **3** an arterial system according to a first embodiment of the invention, generally designated with reference numeral **100**, comprises an arterial flow exchange system in the form of arterial device **200** (also referred to interchangeably herein as an aortic device) and a controller **300**.

[0058] Arterial device **200** is in the form of an aortic cannula, in particular an aortic double-lumen cannula, comprising a distal portion **201** that is configured for being inserted into and accommodated within the aorta **1**, in particular the ascending aorta **2**, during operation of the system **100**, and a proximal portion **202** that is configured for concurrently remaining outside of the aorta **1**.

[0059] Device **200** comprises two internal lumens - a perfusion lumen **210** and an aspiration or suction lumen **220**.

[0060] Distal portion **201** is in the form of a generally tubular elongate member **230**, comprising a double lumen interior defining a respective distal perfusion lumen portion **210a** of perfusion lumen **210**, and a respective distal suction lumen portion **220a** of suction lumen **220**. Distal portion **201** further comprises a perfusion outlet port **240** and a suction inlet port **250**.

[0061] Proximal portion **202** projects proximally from distal portion **201** and branches off from a generally tubular base member **232** having a double lumen interior contiguous with the double lumen interior of the distal portion **201**, to two separate tubular members **234**, **236** each continuing one or another of the lumens, thereby defining a respective proximal perfusion lumen portion **210b** of perfusion lumen **210** and a respective proximal suction lumen portion **220b** of suction lumen **220**. The proximal portion **202** further comprises a perfusion inlet port **245** and a suction outlet port **255** at the proximal end **203** of the proximal portion **202**, on the tubular members **234**, **236** respectively.

[0062] The perfusion lumen **210** thus extends contiguously between the perfusion inlet port **245** and the perfusion outlet port **240**, and provides fluid communication therebetween, via the proximal perfusion lumen portion **210b** and the distal perfusion lumen portion **210a**. Similarly, the suction lumen **220** thus extends contiguously from the suction outlet port **255** to the suction inlet port **250**, and provides fluid communication therebetween, via the proximal suction lumen portion **220b** and the distal suction lumen portion **220a**.

[0063] The device **200** comprises an outer casing **237** and an internal partition wall **235** that separates the perfusion lumen **210** from the suction lumen **220** in the distal portion **201** and the base member **232**.

[0064] Referring also to Figs. **4** to **4o**, the perfusion lumen **210** is gently curved between the perfusion inlet port **245** and the perfusion outlet port **240**, and has a transverse cross-section that smoothly changes between a generally circular form both at the perfusion inlet port **245** and at the perfusion outlet port **240**, to a generally oblate form at an intermediate portion of the perfusion lumen **210** corresponding to the location of the partition wall **235**. The curved path of the perfusion lumen **210** provides a net change in the direction of perfusion flow between the perfusion inlet port **245** and the perfusion outlet port **240** corresponding to angle α between the longitudinal axis **A** of the perfusion lumen **210** at the perfusion inlet port **245** and the longitudinal axis **B** of the perfusion lumen **210** at the perfusion outlet port **240**. The gradual change in the flow direction of the perfusion flow in the perfusion lumen minimizes risk of haemolysis, for example, and enables relatively large perfusion flow rates to be provided to the aorta via the perfusion lumen **210**.

[0065] In this embodiment, angle α is about 110 degrees, though in alternative variations of this embodiment angle α may be between about 90 degrees and about 180 degrees, for example.

[0066] Similarly, the suction lumen **220** is also gently curved between the suction outlet port **255** and the suction inlet port **250**, and has a transverse cross-section than smoothly changes between a generally circular form at the suction outlet port **255** and a generally oblate form at the suction inlet port **240** and extending proximally along a portion of the suction lumen **220** corresponding to the location of the partition wall **235**.

[0067] Thus, elongate member **230** is also mildly curved, and perfusion outlet port **240** is provided at the distal end **204** of the device **200**, so that in use, the perfusion outlet port **240** faces the general downstream (antegrade) flow direction **Q** of the aorta. Distal edge **241** of the perfusion outlet port **240** is rounded (although in alternative variations of this embodiment this distal edge may be tapered or otherwise curved) to facilitate entry into the aorta **1**. The perfusion outlet port **240** is also scarfed with respect to the perfusion lumen **210**, and thus the plane of edge **241** is at an acute angle θ to a reference plane **RP** that is normal to the axis **B**. In this embodiment, angle θ is about 30 degrees, though in alternative variations of this embodiment angle θ may be between about 0 degrees and about 60 degrees, for example. The scarfing of perfusion outlet port **240** also facilitates entry of the distal portion **201** into the aorta **1**.

[0068] The suction inlet port **250** is provided at the outer bend of the curved elongate member **230**, generally opposed to the position of the perfusion outlet port **240** along axis **B**, so that in use of the device **200** the suction inlet port **250** faces the general upstream (retrograde) flow direction **S** of the aorta. The outer edge **251** of suction inlet port **250** is also scarfed in this embodiment and blends with the outer curved profile of the outside **338** of the distal portion **201**, providing a relatively large inlet area as compared with the transverse cross-section of the suction lumen **220** in proximity to suction inlet port **250**.

[0069] In operation of the device **200** and system **100**, the suction inlet port **250** is upstream of the perfusion outlet port **240**.

[0070] Device **200** is configured for operating within an artery, in particular the aorta **1**, more in particular the ascending aorta **2**, in a manner to provide fluid communication between the perfusion outlet port **240** and the suction inlet port **250** within the artery, aorta or ascending aorta, respectively, via the outside **338** of the distal portion **201** of the device **200**.

[0071] Thus, distal portion **201** has an outside **338** (also referred to interchangeably herein as an outer surface of the distal portion **201**) that in use of the device **200** does not occlude or otherwise obstruct the artery, aorta or ascending aorta in which the distal portion **201** is inserted, in particular within a region of the corresponding blood vessel between the location of the suction inlet port **250** and the location of the perfusion outlet port **240**. Furthermore, the device **200**, and in particular the distal portion **201**, has an absence of any occlusion arrangement that is otherwise configured for occluding or obstructing

the artery, in particular the aorta, more particularly the ascending aorta during use of the device such as to prevent such fluid communication between the perfusion outlet port **240** and the suction inlet port **250** via the outside **338**.

[0072] In alternative variations of this embodiment in which the distal portion may be configured with one or more occlusion devices (for example inflatable balloons) positioned at a location inbetween the location of the suction inlet port and the location of the perfusion outlet port, and having an inoperative state in which the occlusion device does not occlude the blood vessel in which the device is installed, and an operative state in which the occlusion device occludes or blocks the blood vessel, such a device is operated with the occlusion device in the aforementioned inoperative state, or at least not in the aforementioned operative state - see for example the embodiment illustrated in Fig.8.

[0073] In operation of the device **200** the suction inlet port **250** is in a position upstream of the perfusion outlet port **240**, with respect to the antegrade flow direction **Q**.

[0074] At the distal end of the proximal portion **202** there is provided a collar **239**. In use of the device **200**, collar **239** abuts against an outer surface of the blood vessel in which the device is inserted, typically the aorta **1** and particularly the ascending aorta **2**, and acts as a stop, preventing the device **200** from being inserted further. The location of the collar **239** with respect to the device **200** is also such as to ensure that when the device **200** is installed in the respective blood vessel, the outside **238** is suitably spaced from the internal walls of the blood vessel. In this embodiment the location of the collar **239** with respect to the device **200** is also such as to ensure that when the device **200** is installed in the respective blood vessel the perfusion outlet port **240** and/or the suction inlet port **250** is also centrally located within the blood vessel, i.e. centrally located with respect to the aortic lumen, so that the perfusion outlet port **240** and/or the suction inlet port **250**, respectively, is generally uniformly spaced with respect to the internal walls of the blood vessel. In alternative variations of this embodiment, the collar **239** may be located with respect to the device **200** such as to ensure that when the device **200** is installed in the respective blood vessel the perfusion outlet port **240** is closer spaced with respect to one part than with respect to another part of the internal walls of the blood vessel.

[0075] The device **200** may be formed from substantially rigid and/or semi-rigid and medically compatible materials, including, for example medically suitable plastics, silicon, rubber or composite materials that are known in the art for use in aortic cannulation devices. The device **200** may thus be configured as disposable device, being made from disposable materials and disposed of after use with a patient. Alternatively, the device may be configured as an autoclavable or otherwise sterilizable and non-disposable device, and formed from stainless steel, titanium or other suitable metals or alloys or any other suitable materials.

[0076] Perfusion lumen **210** is configured for providing at least a nominal perfusion flow, i.e., having a nominal perfusion blood flow rate **NFR**, that is the minimum sufficient for providing adequate fluid flow to the body blood circulation system of the patient, i.e., a perfusion flow rate that is sufficient to sustain the minimum metabolic demands of the patient. In other words, the nominal perfusion flow comprises a fluid including oxygenated blood provided by the extra-corporeal blood oxygenation system (but may also comprise other fluids, for example saline solution), and corresponds to the blood flow that is the minimum normally provided to the aortic arch and the descending aorta of the patient by the heart of the patient at similar conditions. In practice, the nominal perfusion flow rate **NFR** is determined by the medical staff according to conventional practice, as discussed above in the "SUMMARY OF INVENTION" section above. Such nominal perfusion flow rate **NFR** is provided at a nominal flow velocity **NFV** that is below a threshold value **V**. The threshold value **V** is a flow velocity that above which is considered may cause haemolysis or other damage to the blood, for example due to the corresponding shear stresses induced in the blood.

[0077] In particular, the perfusion lumen **210** is configured for providing a target perfusion flow having a target perfusion flow rate **TFR** that is significantly greater than the aforesaid nominal perfusion flow rate **NFR** by a factor ΔFR , referred to herein the excess perfusion flow rate (and also referred to herein interchangeably as the "excess flow rate"). In other words:

$$\text{TFR} = \text{NFR} + \Delta\text{FR}$$

[0078] The perfusion lumen **210** is configured for providing a maximum target perfusion flow having a corresponding maximum target perfusion flow rate TFR_{max} that is greater than the aforesaid nominal perfusion flow rate **NFR** by a corresponding maximum excess perfusion flow rate $\Delta\text{FR}_{\text{max}}$, i.e.,

$$\text{TFR}_{\text{max}} = \text{NFR} + \Delta\text{FR}_{\text{max}}$$

[0079] Thus, in this embodiment, the perfusion lumen **210** comprises a minimum cross-sectional flow area that is correspondingly larger than would be otherwise be required for providing only the nominal perfusion flow rate **NFR**, in order to enable flow rates of up to the aforesaid maximum target perfusion flow rate TFR_{max} , but still at the flow velocities which are still below the aforesaid threshold value **V**.

[0080] In this embodiment, and by way of example, the perfusion lumen is configured for providing maximum target perfusion flow rate TFR_{max} that is about 150% of the nominal perfusion flow rate **NFR**, and thus the corresponding maximum excess perfusion flow rate $\Delta\text{FR}_{\text{max}}$,

is correspondingly about 50% of the nominal perfusion flow rate **NFR**.

[0081] In this embodiment, the perfusion lumen is configured for providing maximum target perfusion flow rate TFR_{max} of greater than about 5.5 or 6 or 6.5 or 7 or 7.5 liters/minute, and a nominal perfusion flow rate **NFR** of about 4 to 5 liters/minute, depending on the particulars of the patient, for example, while the target perfusion flow rate **TFR** may vary in a range between about 3.3 l/min to about 4.5 l/min at nominal perfusion flow rate **NFR** of about 3 l/min, or wherein the target perfusion flow rate **TFR** may vary in a range between about 4.4 l/min to about 6 l/min at nominal perfusion flow rate **NFR** of about 4 l/min, increasing to a range between about 5.5 l/min to about 7.5 l/min at nominal perfusion flow rate **NFR** of about 5 l/min.

[0082] Thus, in this embodiment and at least some alternative variations of this embodiment of the invention, the target perfusion rate may thus vary between a minimum of about 110% of the nominal flow rate **NFR**, to a maximum of about 150%. In at least some other alternative variations of this embodiment or in other embodiments of the invention, the target perfusion rate may vary between a minimum of about 115% of the nominal flow rate **NFR**, to a maximum of about 150%. In at least some other alternative variations of this embodiment or in other embodiments of the invention, the target perfusion rate may vary between a minimum of about 115% of the nominal flow rate **NFR**, to a maximum of about 160%. In at least some other alternative variations of this embodiment or in other embodiments of the invention, the target perfusion rate may vary between a minimum of about 120% of the nominal flow rate **NFR**, to a maximum of about 150%. In at least some other alternative variations of this embodiment or in other embodiments of the invention, the target perfusion rate may vary between a minimum of about 125% of the nominal flow rate **NFR**, to a maximum of about 150%. In at least some other alternative variations of this embodiment or in other embodiments of the invention, the target perfusion rate may vary between a minimum of about 110% of the nominal flow rate **NFR**, to a maximum of about 175%. In at least some other alternative variations of this embodiment or in other embodiments of the invention, the target perfusion rate may vary between a minimum of about 115% of the nominal flow rate **NFR**, to a maximum of about 175%. In at least some other alternative variations of this embodiment or in other embodiments of the invention, the target perfusion rate may vary between a minimum of about 120% of the nominal flow rate **NFR**, to a maximum of about 175%. In at least some other alternative variations of this embodiment or in other embodiments of the invention, the target perfusion rate may vary between a minimum of about 125% of the nominal flow rate **NFR**, to a maximum of about 175%. In at least some other alternative variations of this embodiment or in other embodiments of the invention, the target perfusion rate may vary between a minimum of about 120% of the nominal

inal flow rate NFR, to a maximum of about 170%.

[0083] In this embodiment, and by way of example, the perfusion lumen **210** has an internal diameter of about 7.7cm at the perfusion inlet port **245** and an internal diameter of about 7.6cm at the perfusion outlet port **240**. The suction lumen **220** has an internal diameter of about 4.4cm at the suction outlet port **255**, and the suction inlet port **250** has a maximum width of about 8.8cm due to the scarfing thereof. Furthermore, by way of further example, Fig. 4a to Fig. 4m show geometrically consistent and accurate cross-sections of the embodiment of Fig. 4, taken along numerically labeled sections "0" to "28", respectively, of Fig. 4. It is to be further noted that the numerical label for each of these sections refers to a spacing in mm of the respective section from the first section illustrated in Fig. 4a. Thus, for example, Fig. 4h refers to the cross-section at section "18", which is at 18mm from the section depicted in Fig. 4a. As a datum, section 12 illustrated in Fig 4f is at the proximal end of the distal portion of the device.

[0084] The nominal perfusion blood flow rate **NFR** may of course vary from patient to patient, and is generally a function of, *inter alia*, body weight, age, sex and general health of the particular patient, and may also vary with time, activity and so on. However, according to at least this embodiment of the invention, the target perfusion flow rate **TFR** and the maximum target perfusion flow rate **TFR_{max}** are related to the specific nominal perfusion blood flow rate **NFR** that is unique to the particular patient that is being treated with the system **100** and device **200**, as determined by the medical staff treating the patient.

[0085] The suction lumen **220** has a minimum cross-sectional flow area that is smaller than the minimum cross-sectional flow area of the perfusion lumen **210**, and in this embodiment is configured for providing a suction flow rate **SFR** that can be varied from zero to a maximum suction flow rate **SFR_{max}** that is generally similar to the corresponding maximum excess perfusion flow rate **ΔFR_{max}**.

[0086] The perfusion inlet port **245** is configured for being connected to, and thus for receiving oxygenated blood from, a suitable perfusion source **320**, for example a heart lung machine (also referred to interchangeably herein as a bypass-oxygenator machine) or any other extra-corporeal blood oxygenation system, which are well known in the art, and of which there exist many commercially available examples.

[0087] A suitable pump **325**, for example a peristaltic pump, pumps oxygenated blood from the perfusion source **320** to the device **200**. Pump **325** is configured for providing a controllable perfusion flow rate at least up to the maximum target perfusion flow rate **TFR_{max}** for the particular patient being treated by system **100**, and is variably controllable (by controller **300**) to provide perfusion flow rates from nominally zero to at least up to the maximum target perfusion flow rate **TFR_{max}**.

[0088] The pump **325** is operatively connected to, and is controlled by, controller **300**. Thus, controller **300** is

configured for controlling the pump **325** to provide any desired perfusion flow rate in the range between zero and at least the maximum target perfusion flow rate **TFR_{max}**.

5 [0089] The suction outlet port **255** is configured for being connected to, and thus for returning blood to, a suitable suction source **345**, for example in the form of a medical suction pump, for example a peristaltic pump. Suitable medical suction pumps capable of aspirating or sucking blood are well known in the art, and of which there exists many commercially available examples. In alternative variations of this embodiment, the suction source **345** may comprise a fluid suction line, suitable for suctioning blood or other liquids. In any case, the suction source **345** is selectively controllable, and is operatively connected to, and is controlled by, controller **300**.

10 [0090] The suction source **345** is configured for providing a variably controllable suction flow rate from nominally zero to at least the maximum suction flow rate **SFR_{max}**. The controller **300** is configured for selectively controlling the suction source **345** to provide any desired suction flow rate in the range between zero and at least the maximum suction flow rate **SFR_{max}**.

15 [0091] In at least some operational modes of the system **100**, the suction source **345** sucks or aspirates blood via the device **200** and into a suitable receiving volume **340**. In some alternative variations of this embodiment, the blood collected at receiving volume **340** may be subsequently suitably processed to remove embolic debris and may be then supplied to the perfusion source **320** to provide a closed system.

20 [0092] Thus, in this embodiment and at least some alternative variations of this embodiment of the invention, the suction flow rate may thus vary between a minimum of about 10% of the nominal flow rate NFR, to a maximum of about 50%. In at least some other alternative variations of this embodiment or in other embodiments of the invention, the suction flow rate may vary between a minimum of about 15% of the nominal flow rate NFR, to a maximum of about 50%. In at least some other alternative variations of this embodiment or in other embodiments of the invention, the suction flow rate may vary between a minimum of about 15% of the nominal flow rate NFR, to a maximum of about 60%. In at least some other alternative variations of this embodiment or in other embodiments of the invention, the suction flow rate may vary between a minimum of about 20% of the nominal flow rate NFR, to a maximum of about 50%. In at least some other alternative variations of this embodiment or in other embodiments of the invention, the suction flow rate may vary between a minimum of about 25% of the nominal flow rate NFR, to a maximum of about 50%. In at least some other alternative variations of this embodiment or in other embodiments of the invention, the suction flow rate may vary between a minimum of about 10% of the nominal flow rate NFR, to a maximum of about 75%. In at least some other alternative variations of this embodiment or in other embodiments of the invention, the suc-

tion flow rate may vary between a minimum of about 15% of the nominal flow rate NFR, to a maximum of about 75%. In at least some other alternative variations of this embodiment or in other embodiments of the invention, the suction flow rate may vary between a minimum of about 20% of the nominal flow rate NFR, to a maximum of about 75%. In at least some other alternative variations of this embodiment or in other embodiments of the invention, the suction flow rate may vary between a minimum of about 25% of the nominal flow rate NFR, to a maximum of about 75%. In at least some other alternative variations of this embodiment or in other embodiments of the invention, the suction flow rate may vary between a minimum of about 20% of the nominal flow rate NFR, to a maximum of about 70%.

[0093] Thus, in operation the system 100 comprises arterial device 200 and extra-corporeal circulation system 290, which comprises controller 300, pump 325, perfusion source 320 and suction source 345, and optionally also receiving volume 340.

[0094] In this embodiment, controller 300 comprises a suitable computer system or the like, which may be pre-programmed to operate the system 100 automatically in one or more operating modes, and/or which may be programmed for operating in one or more operating modes manually or interactively, according to operator input. In alternative variations of this embodiment, the controller 300 may instead comprise any other suitable control system, for example an electronic control system, a mechanical control system, or a hydraulic control system, each respectively configured to selectively provide one or more desired operating modes for the system 100.

[0095] The system 100 is particularly configured for causing embolic debris that may be present at least in the ascending aorta 2 to be diverted or directed to the suction inlet port 250 and out of the aorta 1 via the suction lumen 220, in particular at least a majority, and preferably all, the embolic debris, and thus prevent or minimize migration of embolic debris from the ascending aorta 2 to the aortic arch 3. At the same time, the system 100 is also configured for providing the patient with the nominal perfusion flow required for the patient when the heart is not functioning, and/or, for providing the patient with a supplemental perfusion flow required for the patient when the heart is beginning to function again after cardiac surgery and is not yet itself providing the patient with the full required nominal perfusion flow.

[0096] As will become apparent, operation of the system 100 to remove the aforesaid embolic debris does not of itself cause or potentially cause more embolic debris to be created. Furthermore the system 100 can be operated to allow such embolic debris removal operation to be carried out while providing a nominal perfusion flow to the body circulation system, and for the embolic debris removal operation to be phased out, while still providing the required nominal perfusion flow to the patient's body circulation system. Alternatively, the system 100 can be operated to continue removing embolic debris, while

phasing out the nominal perfusion flow function, as the heart begins to take over perfusion of the body from the extracorporeal circulation system.

[0097] The system 100 can thus operate in a number of different operating modes and can switch between different operating modes smoothly. Prior to operating the system 100, the device 200 must be properly positioned in the aorta, the distal portion 201 having been introduced and installed in the ascending aorta 2 of the patient for antegrade deployment by any suitable procedure, for example including any suitable procedure for installing a conventional aortic cannulation device. Such a procedure may include, for example, providing a purse string suture in the wall of the ascending aorta, and an aortotomy incision is made inside the purse string. The distal portion 201 is introduced into the aorta via this incision, and the device 200 secured in place, for example by suturing the collar 239 to the wall of the aorta.

[0098] Thereafter, the heart 9 may be isolated from the aorta for conducting the required cardiac procedure or surgery, for example CPB, by closing off the upstream end of the ascending aorta 2, for example using clamps on the outside of the ascending aorta 2, or by using an occlusion device within the ascending aorta, upstream of the distal portion 201, and by providing oxygenated blood to the body circulation system from perfusion source 320 via the device 200. The heart may be stopped using any one of a variety of techniques which are well known in the art, as required for the cardiac surgery.

NOMINAL PERFUSION OPERATING MODE

[0099] In the nominal perfusion operating mode (NPOM), the system 100 operates to provide oxygenated blood at least at the nominal perfusion flow rate NFR to the body circulation system. In NPOM mode, the controller 300 is configured for controlling the pump 325 to deliver oxygenated blood from perfusion source 320 to the device 200 via the perfusion lumen 210 at the nominal perfusion flow rate NFR, while the suction source 345 is substantially inoperational or on standby, and no significant suction is induced via the suction lumen 220.

[0100] In NPOM mode, the perfusion flow rate may be selectively increased or decreased according to the metabolic needs of the patient, for example, and the device 200 operates in a manner substantially similar to conventional aortic perfusion cannulation devices.

[0101] In NPOM mode, the perfusion flow rate may also be incrementally reduced to zero when the heart is again beating and is in fluid communication with the aorta, and the heart takes over perfusion of the body circulation. However the NPOM mode is in general only used in this manner when there is no suspicion or risk of embolic debris that may be present and potentially harmful to the patient. Where such a suspicion or risk exists, the embolic debris removal operating mode may be used, as described in greater detail below.

EMBOLIC DEBRIS REMOVAL OPERATING MODE

[0102] In the embolic debris removal operating mode (EROM), the system **100** operates to provide oxygenated blood at least at the nominal perfusion flow rate **NFR** to the body circulation system, while concurrently removing embolic debris and preventing the same from flowing to the aortic arch and possibly therefrom to the cerebral circulation system.

[0103] In EROM mode, the controller **300** is configured for controlling the pump **325** to deliver oxygenated blood from perfusion source **320** to the device **200** via the perfusion lumen **210** at a desired target perfusion flow rate **TFR**, while controlling the suction source **345** to provide a suction flow rate **SFR** via the suction lumen **220**.

[0104] In standard EROM mode, the desired target perfusion flow rate **TFR** and the suction flow rate **SFR** are controlled in a manner to match the suction flow rate **SFR** to the excess perfusion flow rate ΔFR that corresponds to the target perfusion flow rate **TFR**, this matching being according to a desired matching level. The desired matching level may range from a minimum matching level, in which the suction flow rate **SFR** is a percentage of the excess perfusion flow rate ΔFR that is less than 100%, such as about 25%, though preferably not less than about 50%, to a maximum matching level, in which the suction flow rate **SFR** is fully (100%) matched to and is substantially equal to the excess perfusion flow rate ΔFR . In some circumstances, the matching level may be even less than 25%, for example when the patient is experiencing bleeding. In other circumstances, the matching level may be greater than 100%, for example when there is a large amount of embolic debris, and the nominal flow rate **NFR** to the patient is temporarily reduced pro-rate, to avoid having to increase the target perfusion rate further.

[0105] In regular operation of the system **100** in EROM mode, the matching level is maintained at about 100%, and the matching level is deviated away from this 100% matching level when there is a special need to do so.

[0106] Without being bound by theory, and referring to Fig. 5, the inventors suggest that by providing a target perfusion flow rate **TFR** that includes the nominal perfusion flow rate **NFR** and the corresponding excess perfusion flow rate ΔFR , and by concurrently providing a suitable suction flow rate **SFR**, a recirculation flow field is set up in the ascending aorta between the perfusion outlet port **240** and the suction inlet port **250**, which are in fluid communication one with the other in use of the system. In steady state conditions, an amount of the blood in the aorta is being continually sucked into the suction lumen **220** via the suction port **250** at the suction flow rate **SFR**, and concurrently the same amount of blood is being replaced by the perfusion flow provided by the perfusion outlet port **240** at a flow rate corresponding to the suction flow rate **SFR**, for conservation of mass flow. Thus, at steady state, at least a proportion **P** of the target perfusion flow rate **TFR** is effectively being cir-

culated into the ascending aorta in retrograde flow, and eventually sucked into the suction inlet port **250**. According to at least this embodiment of the invention, this proportion **P** is fully provided by all the excess perfusion flow rate ΔFR of the target perfusion flow rate **TFR**, so that the remainder of the perfusion flow, i.e., the nominal perfusion flow rate **NFR**, concurrently continues into the aortic arch **3** to supply the minimum metabolic needs of the body via the body circulation system. Thus, the matching level between the suction flow rate **SFR**, and the excess perfusion flow rate ΔFR is 100%. In alternative variations of this embodiment, this proportion **P** is fully provided by a first part of the excess perfusion flow rate ΔFR of the target perfusion flow rate **TFR**, so that the remainder of the perfusion flow, i.e., the nominal perfusion flow rate **NFR**, plus the remainder of the excess perfusion flow rate ΔFR concurrently continues into the aortic arch **3** to supply more than the minimum metabolic needs of the body via the body circulation system, and thus the matching level between the suction flow rate **SFR**, and the excess perfusion flow rate ΔFR is substantially less than 100% .

[0107] Referring to Fig. 6, and again without being limited to theory, the inventors suggest that at relatively low levels of suction flow rate **SFR**, designated herein as SFR_{sub} , the recirculation flow field, indicated in the figure by broken line **360**, is relatively small and may not extend to the internal walls **10** of the ascending aorta **2**, leaving a stagnation zone or "dead zone" **DZ** in the ascending aorta **2** that is substantially unaffected by this recirculation flow field. Under these conditions embolic debris that may exist within the dead zone **DZ** is also substantially unaffected by the recirculation field and is effectively free to migrate to the aortic arch **3**, with potentially serious consequences to the patient. Under these conditions, even if the target perfusion flow rate **TFR** is further increased but while maintaining the low suction flow rate SFR_{sub} , the dead zone still remains, and only the perfusion rate into the body circulation system is increased to above the nominal perfusion flow rate **NFR**.

[0108] Referring to Fig. 7, and again without being limited to theory, the inventors further suggest that as the suction flow rate **SFR** is increased from the low suction flow rate SFR_{sub} to a threshold value of suction flow rate **SFR**, designated herein as $\text{SFR}_{\text{threshold}}$, (and concurrently the target perfusion rate **TPR** is also increased to a corresponding threshold target perfusion rate $\text{TPR}_{\text{threshold}}$ so that at least a minimum perfusion flow is still being provided to the body circulation system at the nominal perfusion flow rate **NFR**), the recirculation flow field gets larger to a threshold recirculation flow field $\text{RFF}_{\text{threshold}}$. At this threshold suction flow rate $\text{SFR}_{\text{threshold}}$, the threshold recirculation flow field $\text{RFF}_{\text{threshold}}$ is such that the retrograde flow originating from the corresponding proportion **P** of the increased target perfusion rate **TPR** and that is being effectively sucked in via the suction inlet port **250** effectively reduces the dead zone **DZ** to zero, so that the threshold

recirculation flow field $RFF_{\text{threshold}}$ now occupies the upstream portion of the ascending aorta, or at least so that the threshold recirculation flow field $RFF_{\text{threshold}}$ extends to the walls **10** of the ascending aorta **2** (the downstream limit of the threshold recirculation flow field $RFF_{\text{threshold}}$ being indicated by the broken line at **362**) such as to effectively prevent migration of embolic debris into the aortic arch **3** from the ascending aorta **2**, or to reduce potential migration of embolic debris. Thus, under these conditions any embolic debris in the ascending aorta **2** is eventually diverted to the suction inlet port **220** and removed via the suction cannula **220**.

[0109] Referring still to Fig. 7, and again without being limited to theory, the inventors further suggest that as the suction flow rate SFR is increased further above the threshold value of suction flow rate $SFR_{\text{threshold}}$, (and concurrently the target perfusion rate TPR is also increased from the corresponding threshold target perfusion rate $TPR_{\text{threshold}}$ so that at least a minimum perfusion flow is still being provided to the body circulation system at the nominal perfusion flow rate NFR), the recirculation flow field RFF gets larger and/or stronger, and is referred to herein as the corresponding closed recirculation flow field $CRFF$. Under such conditions, there is even less risk of migration of embolic debris into the aortic arch **3** than at the aforesaid threshold suction flow rate $SFR_{\text{threshold}}$, the downstream limit **364** of corresponding closed recirculation flow field $CRFF$ moves - further upstream within the ascending aorta **2**.

[0110] Thus, the threshold suction flow rate $SFR_{\text{threshold}}$ may be defined as the minimum suction flow rate in which there is significant reduction in migration of embolic debris into the aortic arch **3** from the ascending aorta **2**, and preferably that such migration of embolic debris is effectively prevented. While the precise value of the threshold suction flow rate $SFR_{\text{threshold}}$ may vary according to the particular circumstances of the patient, inventors consider that the threshold suction flow rate $SFR_{\text{threshold}}$ may vary between about 10% and about 25% of the nominal perfusion flow rate NFR for a particular patient. Thus, example of values for the threshold suction flow rate $SFR_{\text{threshold}}$ may be 10% or 15% or 20% or 25% of the nominal perfusion flow rate NFR for a particular patient.

[0111] Thus, in such conditions, in which the suction flow rate SFR is at or above the threshold value of suction flow rate $SFR_{\text{threshold}}$, (and concurrently the target perfusion rate TPR is also at or above the corresponding threshold target perfusion rate $TPR_{\text{threshold}}$ so that perfusion flow is still being provided to the body circulation system at least at the nominal perfusion flow rate NFR), there is a qualitative as well as a quantitative change in the characteristics and/or effect of the flows provided within the aorta, in particular the ascending aorta, leading to substantial reduction or elimination of migration of embolic debris into the aortic arch **3**, as compared with the flow provided within the aorta at much lower flow rates.

[0112] In any case, a working value for the threshold

suction flow rate $SFR_{\text{threshold}}$ may be ascertained or estimated in a number of ways, which may be patient-unique or general. For example, the anatomy and flow parameters of the aorta of the particular patient or of a standard adult aorta (defined in a suitable manner, for example having an anatomy that is averaged across the population or a statistically significant sample thereof) may be physically modeled, so that a physical model of the aorta is constructed and tested with suitable particles that model the embolic debris. Fluid flows into and out of the device **200** (properly installed in the model to simulate the installation in a real aorta) are provided with fluid that models blood, and the flows are controllably and selectively varied, and the effect on particle migration to the aortic arch, the particles originating upstream of the aorta and/or from the perfusion lumen of the device **200** is determined. At the same time the perfusion flow velocity is preferably kept to below the threshold value V . Thereby, the threshold suction flow rate $SFR_{\text{threshold}}$ may be empirically determined.

[0113] Alternatively, a computer model simulation of the patient's aorta may be created, and a suitable computerized flow analysis conducted in the computer environment of the fluid flows into and out of the aortic device (that is also modeled in the computer simulation), in a computer model similar to the physical model, *mutatis mutandis*.

[0114] In any case, in at least one embodiment of the standard EROM mode, the suction flow rate SFR is set well above the threshold suction flow rate $SFR_{\text{threshold}}$, at or close to the maximum suction flow rate SFR_{max} , and concurrently perfusion is provided at the maximum target perfusion rate TFR_{max} , so that the full corresponding maximum excess perfusion flow rate ΔFR_{max} is effectively used for the removal or potential removal of embolic emboli from the ascending aorta, while sufficient perfusion is provided at the aforesaid nominal perfusion flow rate NFR for the needs of the patient, and while maintaining the target perfusion flow rate flowing at flow velocities below the threshold velocity V .

[0115] The EROM mode can be used whenever necessary or desired, for example in the following situations:

(a) Prior to clamping or occluding the aorta, in anticipation of and to collect possible embolic debris that may be formed thereafter.

(b) After clamping or occluding the aorta, to collect possible embolic debris that may be formed as a result thereof.

(c) After unclamping or removing the occlusion in the aorta, to collect possible embolic debris that may be formed as a result thereof.

(d) Whenever there is a suspicion that embolic debris may be found in the ascending aorta, or where such embolic debris is detected.

(e) Throughout the cardiac procedure, whenever there is a need to provide artificial perfusion to the body circulation system.

[0116] Between (b) and (c), i.e., after it is considered that any possible embolic debris has been diverted and removed via the system **100**, but before it is desired to unclamp or remove the occlusion in the aorta, it is possible to change operating mode from EROM mode to NPOM mode to continue providing nominal perfusion to the body circulating system. This switchover in operating modes only requires the suction flow rate **SFR** to be gradually decreased to zero, while concurrently decreasing the target perfusion rate **TFR** to the nominal perfusion flow rate **NFR**.

[0117] Conversely, just before it is desired to unclamp or remove the occlusion in the aorta, it is possible to change operating mode back to EROM mode from NPOM mode to begin again suctioning, with a suction flow rate increasing from zero to the required value, and the target perfusion flow rate **TFR** similarly increasing, to provide sufficient flow for the recirculation field and to concurrently continue providing nominal perfusion to the body circulating system.

[0118] If after (c) there is still suspicion or evidence of embolic debris in the ascending aorta, the EROM mode can be continued further until all the embolic debris is removed, prior to starting the heart again, after which if there is no further embolic debris the system **100** can switch to operating in NPOM mode, and then reduce the actual perfusion rate to zero as the heart takes over the function of providing oxygenated blood to the body.

[0119] Alternatively, it is possible to continue operating in EROM mode even once the heart starts again, to eliminate embolic debris that originates upstream of the aorta. In particular, the system may be operated in such circumstances in de-airing mode (DAM), to remove embolic debris in the form of air bubbles. In fact, in such a DAM mode, and when the heart is operating and providing part or all of the nominal perfusion, the system may be configured for providing a suction flow rate that is higher than required in other operating modes.

[0120] Referring to (e) above, it may be desired to use EROM mode throughout the cardiac procedure, whenever there is a need to provide artificial perfusion to the body circulation system, for example when there is a risk of embolic debris being generated by the extra-corporeal circulation system and introduced into the patient via the perfusion lumen. Thus EROM may completely replace NPOM mode, and is used continuously until the end of the procedure.

[0121] Thus, it is evident that the system **100** may be used in EROM mode continuously, for example from just before it is desired to clamp or provide the occlusion in the aorta, or even as soon as the device **200** is installed, to after the aorta is unclamped or the occlusion removed therefrom. In such continuous EROM mode, the suction flow rate and the target flow rate may be set at a desired

preset level, or may be varied, but always maintaining a suitable suction flow and a suitable excess perfusion flow.

[0122] It is also evident that the system **100** may be used in an intermittent manner, in which high target perfusion flow rates **TFR** and high suction flow rates **SFR** are provided when there is danger or risk of embolic debris, for example during clamping and unclamping of the aorta, and reducing these flow rates to provide zero suction flow rate or low flow rates at other times.

[0123] In at least some alternative variations of this embodiment a suitable sensor system may be provided to detect the presence of embolic debris in the ascending aorta, for example, and for automatically switching the system to EROM mode (or possibly automatically increasing further the target perfusion flow rates **TFR** and the suction flow rate **SFR**, if already in EROM mode) when embolic debris is detected. Such a sensor may be based on Transcranial Doppler technology (referred to in the art as TCD), for example.

[0124] Once the heart has fully taken over providing perfusion for the body, the device **200** may be removed, for example in a manner used conventionally for removing conventional aortic cannulation devices.

[0125] It is to be noted that in the absence of contact between the distal portion **201** and the walls **10** of the aorta (other than due to penetration of the distal portion **201** into the aorta), operation of the system **100** or stopping operation of the system **100** at least according to this embodiment does not per se result in the significant or actual creation of new embolic debris.

[0126] An alternative variation of the first embodiment is illustrated in Fig. **3(a)**, in which the device **200** is further modified to include an additional suction inlet port in the form of an air bubble suction inlet **262** that is particularly configured for removing embolic emboli in the form of air bubbles that may be released into the aorta when the aorta is unclamped, for example, and thus the arterial device **200** of Fig. **3(a)** may be operated as a de-airing device. As may be seen, the air bubble suction inlet **262** is in communication with the suction lumen **220**, and is located in the distal portion **201** at a location that, in operation of the device **200**, is close to the inner wall of the aorta **2**, preferably at a gravitationally high point in the aortic walls, facilitating migration of air bubbles thereto for subsequent removal thereof.

[0127] An alternative variation of the first embodiment is illustrated in Fig. **8**, in which the device **200** is further modified to include a selectively enlargable device **400** on the external wall **238** of the distal portion **201**. The enlargable device **400** in this embodiment comprises an inflatable annular balloon member **410** than may be selectively inflated from a deflated condition, in which the balloon member **410** is close to the external wall **238**, to an inflated condition, illustrated in Fig. **8**, in which the balloon member **410** partially obstructs the cross-section of the ascending aorta, but still allows for significant fluid communication between the inlet suction port **250** and

the perfusion outlet port **250**. In particular, the balloon member **410** does not abut or engage with the aortic walls **10**, and preferably does not come in contact the aortic walls **10**, in use of the device and when the balloon member **410** is in the inflated condition. Use of this embodiment in NPOM mode is similar to that described herein for the first embodiment, *mutatis mutandis*, and in this mode the balloon member may be inflated or deflated. Similarly, use of this embodiment in EROM mode is similar to that described herein for the first embodiment, *mutatis mutandis*, and in this mode the balloon member may also be inflated or deflated, though when inflated, it may operate more efficiently in removing embolic debris even where the suction flow rate is lower than the aforesaid threshold suction flow rate $SFR_{\text{threshold}}$.

[0128] Another alternative variation of the first embodiment is illustrated in Fig. 9, in which the distal portion, designated **201'**, is similar to the distal portion **201** disclosed for the first embodiment, *mutatis mutandis*, with some differences. These differences include:

- in distal portion **201'** of the embodiment of Fig. 9, the distal end **204'** of the device now extends into the aortic arch **3**;
- distal portion **201'** includes a plurality of perfusion outlet ports **240'** rather than the single perfusion outlet port **240** of the first embodiment;
- distal portion **201'** includes a plurality of suction inlet ports **250'** rather than the single suction inlet port **250** of the first embodiment illustrated in Fig. 3, and thus may also include a de-airing suction port similar to that illustrated for embodiment of Fig. 3a.

[0129] Further, at least one or more perfusion outlet ports **240'**, designated **240a'** are located at a position to be within the ascending aorta **2** when the aortic device is installed therein, similar to the position of the single perfusion outlet port **240** of the first embodiment, and have a combined exit flow area of A_a . Another group of one or more perfusion outlet ports **240'**, designated **240b'** are located at a position to be within the aortic arch **3**, close to the upstream end **3U** thereof, when the arterial device is installed therein, and have a combined exit flow area of A_b . Another group of one or more perfusion outlet ports **240'**, designated **240c'** are located at a position to be within the aortic arch, further downstream of perfusion outlet ports **240b'**, and have a combined exit flow area of A_c . Finally, the distal end **204'** comprises another outlet port **240'**, designated **240d'**, and having an exit flow area of A_d . (Optionally, further perfusion outlet ports may be provided at different locations on the distal end **201'**.)

[0130] The combined exit flow areas of all the perfusion outlet ports **240'** is such as to provide the desired target perfusion flow rate **PFR**, while maintaining the exit velocity below the threshold velocity V . Furthermore, the relative sizes exit flow area of A_a , A_b , A_c and A_d can be

set so that the desired flow at the nominal perfusion flow rate **NPR** is provided via perfusion outlet ports **240c'** and perfusion outlet ports **240d'**, for example, while the excess perfusion flow at excess perfusion flow rate ΔFR , or at least the proportion **P** of the target perfusion flow rate **TFR** for matching the suction flow rate **SFR**, is provided via perfusion outlet ports **240a'** and perfusion outlet ports **240b'**. Alternatively, the perfusion flow from the perfusion outlet ports **240b'** may be used for the nominal perfusion flow rate **NPR** instead of for the excess perfusion flow rate ΔFR .

[0131] Operation of the embodiment of Fig. 9 is similar to that disclosed herein for the first embodiment, *mutatis mutandis*.

[0132] In yet other alternative variations of the first embodiment or of the above variations thereof, the arterial device may comprise a perfusion lumen arrangement having a plurality of perfusion lumens, each in fluid communication with one or more suitable perfusion sources, and each one providing perfusion flow via the same perfusion outlet port or via a plurality of perfusion outlet ports, and/or, the arterial device may comprise a suction lumen arrangement having a plurality of suction lumens, each in fluid communication with one or more suitable suction sources, and each one providing suction flow via the same suction inlet port or via a plurality of suction inlet ports.

[0133] A feature of the first embodiment and at least some alternative variations thereof is that a single entry point is required in the aorta, in particular the ascending aorta, for providing the dual functions of providing perfusion to the body circulation system and for removing embolic debris (and optionally also de-airing), and furthermore, the same arterial device may be used for providing perfusion where it is not desired to operate the embolic debris removal functionality of the arterial device.

[0134] The first embodiment, or at least some alternative variations thereof, may be operated according to one or more of the following operating parameters:

- wherein said nominal perfusion flow rate is in the range between about 3 liters per minute to about 5 liters per minute;
- wherein said target flow rate is in the range between about 3.3 liters per minute to about 7.5 liters per minute;
- wherein said excess perfusion flow rate is in the range between about 0.3 liters per minute to about 2.5 liters per minute;
- wherein said suction flow rate is greater than 0.5 liters per minute;
- wherein said suction flow rate is greater than 0.75 liters per minute;

- wherein said suction flow rate is greater than 1 liter per minute;
- wherein said suction flow rate is greater than 1.25 liters per minute;
- wherein said suction flow rate is in the range between about 0.5 liters per minute to about 2.0 liters per minute;
- wherein said suction flow rate is in the range between about 0.5 liters per minute to about 2.5 liters per minute;
- wherein said suction flow rate is in the range between about 0.75 liters per minute to about 2.5 liters per minute.

[0135] Referring to Figs. 10 and 11, an arterial system according to a second embodiment of the invention, designated herein with the reference numeral **500**, comprises all the elements and features of the system according to the first embodiment and/or alternative variations thereof and may be operated in a similar manner thereto and with similar operating parameters, *mutatis mutandis*, with a number of differences, as follows. In particular, arterial system **700** comprises an arterial device **500** (also referred to interchangeably herein as an aortic device), and controller **300**. Controller **300** is as disclosed for the first embodiment, *mutatis mutandis*, and is operatively connected to, and selectively controls, pump **325** and suction source **345**, also as disclosed for the first embodiment, *mutatis mutandis*.

[0136] Arterial device **700** is in the form of an aortic catheter, in particular an intra-aortic double-lumen catheter, configured for being inserted into the aorta **1**, in particular the ascending aorta **2**, during operation of the system **100**, via a suitable insertion point **799**, well downstream of the aortic arch **3**. In this embodiment, the insertion point **799** is in the femoral artery of the patient, but in alternative variations of this embodiment, the insertion point may instead be one of the iliac arteries **8**, or a suitable location in the abdominal portion of the descending aorta **4**, or indeed any other suitable point along the descending aorta.

[0137] Device **700** comprises two internal lumens - a perfusion lumen **710** and an aspiration or suction lumen **720**, and comprises a generally tubular outer wall **730** concentric with a generally tubular inner wall **740**. Perfusion lumen **710** is defined in the annular space between the inner wall **735** and the outer wall **730**, while suction lumen **720** is defined by the space enclosed by the inner wall **735**. At a distal end **704** of the device **700** the suction lumen **720** opens to a suction inlet port **750**, while the annular space between the inner wall **735** and the outer wall **730** is closed by end wall **760**, indicating the distal end of the perfusion lumen **710**. Thus, suction inlet port **750** is distal end of the device **700** and in use the suction

inlet port **750** faces in a general upstream direction S of the aorta.

[0138] The device **700** comprises a distal portion **701** configured for being accommodated within the aorta, so that in use of the system **500** the distal end **704** is located within the ascending aorta **2** of the patient. A proximal end **705** of the distal portion **701** is located at the entry point **799** in use of the system **500**.

[0139] The proximal end **705** of the device **700** is contiguous with a proximal portion **702** of the device, and the proximal portion **702** comprises a perfusion inlet port **745** and a suction outlet port **755**. The proximal portion **702** thus projects out of the entry point **799** of the body and interfaces with other components of the system **500**. The proximal portion **702** is configured for remaining outside of the entry point **799** concurrently when the distal portion **701** is installed in the aorta.

[0140] The distal portion **701** further comprises a plurality of perfusion outlet ports, collectively designated **740**, laterally or radially disposed on the outer wall **730**. One or more perfusion outlet ports **740** are located on the device **700** to be distally of the aortic arch **3**, i.e., in the ascending aorta **2**, in operation of the device **700**, and are also designated herein as distal perfusion outlet ports **740d**. Additional one or more outlet ports **740** are located proximally of the distal perfusion outlet ports **740d** are designated herein as proximal perfusion outlet ports **740p**. In the illustrated embodiment, the proximal perfusion outlet ports **740p** are located on the device **700** to be in or just downstream of the aortic arch **3**, in the upper portion of the thoracic descending aorta, in operation of the system **500**. However, in alternative variations of this embodiment, the proximal perfusion outlet ports **740p** may instead be located on the device **700** to be within the aortic arch **3**, or in the ascending aorta **2** but downstream of the suction inlet port **750**, or in the abdominal portion of the descending aorta **4**, in operation of the device. In yet other alternative variations of this embodiment, the proximal perfusion outlet ports **740p** are integral with the distal perfusion outlet ports **740d**.

[0141] Returning to the second embodiment illustrated in Figs. **10** and **11**, the perfusion lumen **710** thus extends contiguously between the perfusion inlet port **745** and the perfusion outlet ports **740**, and provides fluid communication therebetween. Similarly, the suction lumen **720** thus extends contiguously from the suction outlet port **755** to the suction inlet port **750**, and provides fluid communication therebetween. Furthermore, the perfusion outlet ports **740** are downstream of the suction inlet port **750** (in terms of the antegrade aorta flow).

[0142] Device **700** is configured for operating within an artery, in particular the aorta **1**, more in particular the ascending aorta **2**, in a manner to provide fluid communication between the perfusion outlet ports **740** and the suction inlet port **750** within the artery, aorta or ascending aorta, respectively, via the outside **738** of the distal portion **701** of the device **700**.

[0143] Thus, distal portion **701** has an outside **738** (al-

so referred to interchangeably herein as an outer surface of the distal portion **701**) that in use of the device **700** does not occlude or otherwise obstruct the artery, aorta or ascending aorta in which the distal portion **701** is inserted, in particular within a region of the corresponding blood vessel between the location of the suction inlet port **750** and the location of the perfusion outlet ports **740**. Furthermore, the device **700**, and in particular the distal portion **701**, has an absence of any occlusion arrangement that is otherwise configured for occluding or obstructing the artery, in particular the aorta, more particularly the ascending aorta during use of the device such as to prevent such fluid communication between the perfusion outlet ports **740** and the suction inlet port **750** via the outside **738**.

[0144] In alternative variations of this embodiment in which the distal portion may be configured with one or more occlusion devices (for example inflatable balloons) positioned at a location inbetween the location of the suction inlet port and the location of the perfusion outlet ports, and having an inoperative state in which the occlusion device does not occlude the blood vessel in which the device is installed, and an operative state in which the occlusion device occludes or blocks the blood vessel, such a device is operated with the occlusion device in the aforementioned inoperative state or at least not in the aforementioned operative state.

[0145] At the distal end of the proximal portion **702** there is provided a collar **739**. In use of the device **700**, collar **739** abuts against an outer surface of the blood vessel in which the device is inserted, via the entry point **799**, and may be used to limit the penetration of the device **700** into the aorta so that in this position the distal end **704** is at the desired location within the ascending aorta. Furthermore, the collar **739** may assist in affixing the device **700** to the body.

[0146] The device **700** may be formed from substantially rigid and/or semi-rigid and medically compatible materials, including, for example including medically suitable plastics, silicon, rubber or composite materials that are known in the art for use in aortic catheter devices. The device **700** may thus be configured as disposable device, being made from disposable materials and disposed of after use with a patient. Alternatively the device may be configured as an autoclavable or otherwise sterilizable and non-disposable device, and formed from suitable materials.

[0147] In a similar manner to that disclosed for the first embodiment, *mutatis mutandis*, perfusion lumen **710** is configured for providing at least a nominal perfusion flow, i.e., having a nominal perfusion blood flow rate **NFR**, provided at a nominal flow velocity **NFV** that is below a threshold value V , and in particular, the perfusion lumen **710** is configured for providing a target perfusion flow having a target perfusion flow rate **TFR** that is significantly greater than the aforesaid nominal perfusion flow rate **NFR** by a factor ΔFR , referred to herein the excess perfusion flow rate. Furthermore, the perfusion lumen **710**

is configured for providing a maximum target perfusion flow having a corresponding maximum target perfusion flow rate **TFR_{max}** that is greater than the aforesaid nominal perfusion flow rate **NFR** by a corresponding maximum excess perfusion flow rate ΔFR_{max} . Thus, in the second embodiment, the perfusion lumen **710** also comprises a minimum cross-sectional flow area that is correspondingly larger than would be otherwise be required for providing only the nominal perfusion flow rate **NFR**, in order to enable flow rates of up to the aforesaid maximum target perfusion flow rate **TFR_{max}**, but still at the flow velocities which are still below the aforesaid threshold value V .

[0148] In a similar manner to that disclosed for the first embodiment, *mutatis mutandis*, suction lumen **720** has a minimum cross-sectional flow area that is smaller than the minimum cross-sectional flow area of the perfusion lumen **710**, and in the second embodiment is configured for providing a suction flow rate **SFR** that can be varied from zero to a maximum suction flow rate **SFR_{max}** that is generally similar to the corresponding maximum excess perfusion flow rate ΔFR_{max} .

[0149] The perfusion inlet port **745** is configured for being connected to, and thus for receiving oxygenated blood from, a suitable perfusion source **320**, as disclosed for the first embodiment, *mutatis mutandis*. A suitable pump **325**, as disclosed for the first embodiment, *mutatis mutandis*, pumps oxygenated blood from the perfusion source **320** to the device **700**, and is configured for providing a controllable perfusion flow rate at least up to the maximum target perfusion flow rate **TFR_{max}** for the particular patient being treated by system **100**, and is variably controllable to provide perfusion flow rates from nominally zero to at least up to the maximum target perfusion flow rate **TFR_{max}**.

[0150] Thus, as with the first embodiment, *mutatis mutandis*, the pump **325** is operatively connected to, and is controlled by, controller **300**, and controller **300** is configured for controlling the pump **325** to provide any desired perfusion flow rate in the range between zero and at least the maximum target perfusion flow rate **TFR_{max}**.

[0151] The suction outlet port **755** is configured for being connected to, and thus for returning blood to, a suitable suction source **345**, as disclosed for the first embodiment, *mutatis mutandis*, and the suction source **345** is controllable and is operatively connected to, and is controlled by, controller **300**.

[0152] Thus, as with the first embodiment, *mutatis mutandis*, the suction source **345** is configured for providing a variably controllable suction flow rate from nominally zero to at least the maximum suction flow rate **SFR_{max}**, and the controller **300** is configured for controlling the suction source **345** to provide any desired suction flow rate in the range between zero and at least the maximum suction flow rate **SFR_{max}**.

[0153] In at least some operational modes of the system **500**, the suction source **345** sucks or aspirates blood via the device **700** and into a suitable receiving volume

340. As with the first embodiment, *mutatis mutandis*, in alternative variations of the second embodiment as well, the blood collected at receiving volume **340** may be subsequently suitably processed to remove embolic debris and may be then supplied to the perfusion source **320** to provide a closed system.

[0154] Thus, in operation the system **500** comprises arterial device **200** and extra-corporeal circulation system **690**, which comprises controller **300**, pump **325**, perfusion source **320** and suction source **345**, and optionally also receiving volume **340**. Extra-corporeal circulation system **690** is thus substantially similar or identical to extra-corporeal system **290** of the first embodiment.

[0155] In operation of the system **500**, the distal portion **701** is inserted into the aorta **2** via the aforementioned entry point **799** and navigated upstream until the distal end **704** is located within the ascending aorta **2**. Surgical procedures for inserting intra-aortic catheters from an entry point in the descending aorta or further downstream such as the iliac arteries or femoral arteries are well known in the art.

[0156] System **500** can be operated in a manner similar to that described for the first embodiment, *mutatis mutandis*, and thus may be operated in the nominal perfusion operating mode (NPOM), in which the system **500** operates to provide oxygenated blood at least at the nominal perfusion flow rate **NFR** to the body circulation system, and/or in the embolic debris removal operating mode (EROM), in which the system **500** operates to provide oxygenated blood at least at the nominal perfusion flow rate **NFR** to the body circulation system, while concurrently removing embolic debris and preventing the same from flowing to the aortic arch **3**, as disclosed above, *mutatis mutandis*.

[0157] Other than the difference in the method of introducing the aortic device into the aorta, the main difference in operation of the system **500** of the second embodiment, as compared to system **100** of the first embodiment, is that in the second embodiment the perfusion flow provided via the perfusion lumen **710** exists the perfusion lumen at the plurality of perfusion outlet ports **740**. In NPOM mode perfusion blood is provided at the nominal perfusion flow rate **NFR** via the distal perfusion outlet ports **740d** and the proximal perfusion outlet ports **740p**, and the flow from the latter may be antegrade and/or retrograde, according to the relative sizes of the distal perfusion outlet ports **740d** and the proximal perfusion outlet ports **740p** and their locations in the aorta, so that the arteries that branch off from the aortic arch may receive blood from the distal perfusion outlet ports **740d** and possibly also from the proximal perfusion outlet ports **740p**. In EROM mode, the relative sizes of the distal perfusion outlet ports **740d** and the proximal perfusion outlet ports **740p** and their locations in the aorta may be such that the proportion P of the target perfusion flow rate **TFR** that sustains the suction flow rate **SFR** may be provided solely via the distal perfusion outlet ports **740d**, while the remainder of the target perfusion to the body circulation

system may be provided solely via the proximal perfusion outlet ports **740p** or may be contributed to also via the distal perfusion outlet ports **74**.

[0158] In an alternative variation of the second embodiment, illustrated in Fig. **12**, the distal end **704'** of the device **700** comprises a closed end wall **739** and a tubular wall extension **737** extending distally from outer wall **730** distally of annular wall **760**, defining a distal portion of the suction lumen **720**. Distal end **704'** comprises a plurality of inlet suction ports **750'**, instead of the single inlet suction port **750** of the second embodiment, and are laterally or radially disposed on the tubular wall extension **737**. In this embodiment the suction lumen **720** thus extends contiguously from the suction outlet port **755** to the suction inlet ports **750'**, and provides fluid communication therebetween.

[0159] Installation and operation of the embodiment illustrated in Fig. **12** is similar to that disclosed for the second embodiment illustrated in Figs. **10** and **11**, *mutatis mutandis*.

[0160] Referring to Fig. **13**, an arterial system according to a third embodiment of the invention, designated herein with the reference numeral **800**, comprises all the elements and features of the system according to the first embodiment and/or alternative variations thereof and may be operated in a similar manner thereto and with similar operating parameters, *mutatis mutandis*, with a number of differences, as follows. In particular, arterial system **800** comprises an arterial fluid exchange system **810**, and controller **300'**.

[0161] In the third embodiment, the function of providing the body with the nominal perfusion flow rate **NFR** and the function of causing embolic debris to be removed (e.g., by providing a recirculation flow field) are separately performed by two separate arterial devices. Thus, the arterial fluid exchange system **810** comprises an embolic debris removal device **820** and an arterial perfusion cannula **830**. Controller **300'** is similar to the controller **300** of the first embodiment, *mutatis mutandis*, but is configured for selectively controlling the fluid flows through embolic debris removal device **820** and arterial perfusion cannula **830**.

[0162] Arterial perfusion cannula **830** is configured for providing perfusion to the body circulation system, and thus provide the nominal perfusion flow rate **NFR**. The arterial perfusion cannula **830** is in fluid communication with a suitable perfusion source **320a** via pump **325a**, similar to the perfusion source **320** and pump **320** of the first embodiment, *mutates mutandis*. The perfusion cannula **830** thus has a lumen that is of a suitable size and form to enable the required nominal perfusion flow rate **NFR** to be supplied to the body circulation system, and controller **300'** controls operation of the pump **320a**, and thus of the nominal perfusion flow rate **NFR**.

[0163] In this embodiment, the arterial perfusion cannula **830** is inserted into the aorta in a manner similar to conventional aortic cannulation devices used for perfusion, and is located downstream of the embolic debris

removal device **820**.

[0164] The embolic debris removal device **820** of this embodiment is similar in form to the aortic device **500** of the first embodiment, and alternative variations thereof, *mutatis mutandis*, but with some differences as will become clearer herein. The embolic debris removal device **820** thus comprises a distal portion that is inserted into the ascending aorta **2**, and comprises a perfusion lumen **210a** and a suction lumen **220a**. The perfusion lumen **210a** is in fluid communication with a second perfusion source **320b**, via pump **325b**, similar to the first embodiment, *mutatis mutandis*. The suction lumen **220a** is in fluid communication with a suction source such as pump **345** and optionally reservoir **340**, as in the first embodiment, *mutatis mutandis*, and may in all respects be substantially identical to the corresponding components of the first embodiment, *mutatis mutandis*. The pumps **345** and **325b** are operatively connected to, and are electively controlled by, controller **300**.

[0165] In alternative variations of this embodiment, a single pump may be used to carry out the functions of pumps **345** and **325b**.

[0166] In alternative variations of this embodiment, first perfusion source **320a** and second perfusion source **320b** are integrated into a single perfusion source.

[0167] Perfusion lumen **210a** is similar to the perfusion lumen **210** of the first embodiment, *mutatis mutandis*, but differs therefrom in that in the third embodiment, the perfusion lumen **210a** is configured for providing only the excess perfusion flow ΔFR into the aorta, rather than the full target perfusion flow rate TFR. Thus, the internal cross section of the perfusion lumen **210a** may be correspondingly smaller with respect to the perfusion lumen of the first embodiment, *mutatis mutandis*.

[0168] Thus, while arterial fluid exchange system **810** provides the target flow rate TFR into the aorta, the arterial perfusion cannula **830** is configured for providing the nominal perfusion flow rate NFR while the embolic debris removal device **820** provides the remainder of the target perfusion flow rate, i.e., the excess perfusion flow rate ΔFR .

[0169] Arterial system **800** thus operates in a similar manner to the arterial system **100** of the first embodiment, including operating modes such as the EROM and the NPOM mode, as disclosed for the first embodiment, *mutatis mutandis*, with the main differences including that the excess perfusion flow rate ΔFR is also matched at a desired matching level to the suction flow rate SFR (in a similar manner to that disclosed above for the first embodiment, *mutatis mutandis*), but via the embolic debris removal device **820**, while the nominal perfusion flow NFR is being selectively provided by the arterial perfusion cannula **830** independently thereof. Of course, it is possible to operate the embolic debris removal device **820** to provide an excess perfusion flow rate ΔFR that is higher than the suction flow rate SFR, and thus the excess perfusion flow rate ΔFR will also effectively provide perfusion flow to the body circulation system, or to provide

an excess perfusion flow rate ΔFR that is less than the suction flow rate SFR, and concurrently operate the arterial perfusion cannula **830** to provide a perfusion flow rate that is higher than the nominal perfusion flow rate NPR to compensate.

[0170] Without being bound by theory, inventors consider that when the excess perfusion flow rate ΔFR is suitably matched to the suction flow rate SFR, and the suction flow rate SFR is above the threshold value discussed above, a substantially self-contained recirculation field may be set up between the perfusion outlet **832** of the perfusion lumen **210a**, and the suction inlet **834** of the suction lumen **834** of the suction lumen **220a**, in a similar manner to that discussed above for the first embodiment, *mutatis mutandis*. However, for this to occur, the arterial perfusion cannula **830** is operated to provide a perfusion flow rate sufficient to effectively or actually create a stagnation zone Z inbetween the locations of the arterial perfusion cannula **830** and the embolic debris removal device **820**. The recirculation flow field generated by the embolic debris removal device **820** causes embolic debris that may be present in the aorta to be diverted to the suction inlet **834** and is subsequently removed.

[0171] The embolic debris removal device **820** may optionally comprise a flow diverter **250** facing the perfusion outlet **832** and spaced therefrom, to facilitate recirculation of the excess perfusion flow rate ΔFR in a retrograde direction towards the upstream part of the ascending aorta.

[0172] A feature of this embodiment or at least one alternative variation thereof is that the perfusion lumen **210a** of the embolic debris removal device **820** can be designed to be much smaller than the perfusion lumen of the first embodiment, for example, and thus the overall size of embolic debris removal device **820** may be reduced as compared to the aortic device of the first embodiment, for example. Alternatively, the perfusion lumen **210a** may be of increased size (for example as in the aortic device of the first embodiment) which effectively reduces the flow velocity at the perfusion outlet **832** for a given excess perfusion flow rate ΔFR .

[0173] Another feature of this embodiment or at least one alternative variation thereof is that the excess perfusion rate ΔFR can be fully matched (matching level of 100%) to the suction flow rate SFR in the embolic debris removal device **820**, which is a separate device to the arterial perfusion cannula **830**. Thus, since substantially all the excess perfusion rate ΔFR is effectively recirculated within the ascending aorta and sucked out as the suction flow rate, a perfusion fluid may be used for this that is different from that of the perfusion flow being provided by the arterial perfusion cannula **830**. For example, a suitable saline solution or blood plasma may be used as the perfusion fluid provided to the embolic debris removal device **820** instead of oxygenated blood, to provide the excess perfusion rate ΔFR , and this is subsequently removed via the suction lumen **220a** together with embolic debris. A feature of this arrangement is that it is not

necessary to use up valuable oxygenated blood for the purpose of removing the embolic emboli. Another feature of this is that flow velocities may be used for the excess perfusion rate ΔFR can be greater than the threshold velocity referred to above, since the operating fluid is now saline solution (for example) and not blood that could otherwise be damaged.

[0174] As in the first embodiment or alternative variations thereof, the embolic debris removal device **820** may comprise an air bubble suction inlet **838** that is particularly configured for removing embolic emboli in the form of air bubbles that may be released into the aorta when the aorta is unclamped, for example, similar in form and function to the air bubble suction inlet of the first embodiment, *mutatis mutandis*, and thus the embolic debris removal device **820** may be operated as a de-airing device.

[0175] Referring to Fig. 14, an arterial system according to a fourth embodiment of the invention, designated herein with the reference numeral **900**, comprises all the elements and features of the system according to the third embodiment and/or alternative variations thereof and may be operated in a similar manner thereto and with similar operating parameters, *mutatis mutandis*, with a number of differences, as follows. In particular, arterial system **800** comprises an arterial fluid exchange system **840**, and controller **300'**.

[0176] As with the third embodiment, in the fourth embodiment, the function of providing the body with the nominal perfusion flow rate **NFR** and the function of providing a recirculation flow field to cause embolic debris to be removed are separated and performed by two separate devices. Thus, the arterial fluid exchange system **840** comprises the embolic debris removal device **820**, as disclosed for the third embodiment or alternative variations thereof, *mutatis mutandis*, and an arterial perfusion catheter **860**. Controller **300'** is as disclosed with respect to the third embodiment, *mutatis mutandis*.

[0177] As with the third embodiment, the perfusion lumen **210a** is in fluid communication with a second perfusion source **320b**, via pump **325b**, and the suction lumen **220a** is in fluid communication with a suction source such as pump **345** and optionally reservoir **340**, and the pumps **345** and **325b** are operatively connected to, and are selectively controlled by, controller **300'**.

[0178] Arterial perfusion catheter **860** is configured for providing perfusion to the body circulation system, and thus for providing the nominal perfusion flow rate **NFR**. The arterial perfusion catheter **860** is similar in function to the arterial perfusion cannula of the third embodiment, and is in fluid communication with perfusion source **320a** via pump **325a**, as disclosed for the third embodiment, *mutates mutandis*. The perfusion catheter **860** thus has a lumen that is of a suitable size and form to enable the required nominal perfusion flow rate **NFR** to be supplied to the body circulation system, and controller **300'** controls operation of the pump **320a**, and thus of the nominal perfusion flow rate **NFR**.

[0179] In this embodiment, the arterial perfusion cath-

eter **860** is inserted into the aorta in a manner similar to conventional aortic catheter devices used for perfusion, and is located downstream of the embolic debris removal device **820**. For example, the arterial perfusion catheter **860** may be inserted into the aorta and navigated into a position in the aortic arch **3**, similar to that disclosed herein for the aortic device **700** of the second embodiment, *mutatis mutandis*.

[0180] Arterial system **900** thus operates in a similar manner to the arterial system **800** of the third embodiment, including operating modes such as the EROM and the NPOM mode, and also for de-airing via air bubble suction inlet **838**, as disclosed for the third embodiment, *mutatis mutandis*, with the main differences being that a perfusion catheter is used for providing the nominal flow rate **NFR** to the body circulation, rather than a perfusion cannula. Accordingly, the arterial system **900** shares many of the features of the arterial system of the third embodiment, and has at least another feature in that it avoids having to provide two entry points at or close to the ascending aorta.

[0181] In the method claims that follow, alphanumeric characters and Roman numerals used to designate claim steps are provided for convenience only and do not imply any particular order of performing the steps.

[0182] Finally, it should be noted that the word "comprising" as used throughout the appended claims is to be interpreted to mean "including but not limited to".

[0183] While there has been shown and disclosed example embodiments in accordance with the invention, it will be appreciated that many changes may be made therein without departing from the scope of the invention as claimed.

Claims

1. An arterial system, comprising an arterial flow exchange system and a controller, for use with a patient having an aorta and a body blood circulation system, wherein:

said arterial flow exchange system comprises a distal portion arrangement configured for being accommodated in the aorta of the patient in use of the arterial flow exchange system, said distal portion arrangement comprising:

a perfusion lumen arrangement having at least one perfusion outlet and connectable to at least one perfusion source, said perfusion lumen arrangement being configured for providing therethrough a target perfusion flow into the aorta having a target perfusion flow rate that is greater than a nominal perfusion flow rate by an excess perfusion flow rate, wherein said nominal perfusion flow is sufficient for providing ade-

- quate fluid flow to the body blood circulation system of the patient;
and
a suction lumen arrangement having at least one suction inlet and connectable to a suction source, said suction lumen arrangement being configured for providing a suction flow out of the aorta, said suction flow having a suction flow rate;
said distal portion being configured for providing fluid communication between at least one said perfusion outlet and at least one said suction inlet within the aorta via an outside of said distal portion, in use of the arterial system;
- said controller being configured, in use of the arterial system, for:
- selectively controllably providing a target perfusion flow into the aorta at said target perfusion flow rate;
selectively controllably providing a suction flow out of the aorta at said suction flow rate;
and
selectively controlling said target perfusion flow rate and said suction flow rate concurrently to cause embolic debris that may be present in the aorta to be diverted to said at least one suction inlet.
2. The system according to claim 1, wherein said controller is configured for selectively controlling said target perfusion flow rate and said suction flow rate to establish a recirculation flowfield between at least one said perfusion outlet and at least one said suction inlet within the aorta to cause the embolic debris that may be present in the aorta to be diverted to the respective at least one said suction inlet.
 3. The system according to claim 1 or claim 2, wherein said suction flow rate is a proportion of a said nominal perfusion flow rate, wherein said proportion is not less than about 10% of said nominal perfusion flow rate.
 4. The system according to any one of claims 1 to 3, wherein said arterial flow exchange system is embodied in an arterial device, and said distal portion arrangement constitutes a distal portion of said arterial device and is configured for being accommodated into the aorta, wherein said arterial device is in the form of an aortic cannula, wherein said distal portion is configured for being introduced into the aorta via a wall of the ascending aorta.
 5. The system according to claim 4, wherein said distal portion comprises a curved portion and a distal end,

wherein said distal end comprises said at least one perfusion outlet, and wherein said curved portion comprises said at least one suction inlet.

6. The system according to claim 4 or claim 5, wherein said perfusion lumen arrangement comprises a first lumen, wherein said suction lumen arrangement comprises a second lumen, and wherein said first lumen and said second lumen are integrally formed in said distal portion, wherein said first lumen has a first flow cross-section and said second lumen has a second flow cross-section, wherein a cross section ratio between said first flow cross-section and said second flow cross-section is not less than about 1.10.
7. The system according to claim 6, wherein said cross section ratio is between about 1.10 and about 10.0.
8. The system according to claim 4, wherein said arterial device is in the form of an aortic catheter, wherein said distal portion is configured for being introduced into the aorta via an entry point at a location downstream of the descending aorta, the distal portion being further configured for being navigated upstream to the ascending aorta.
9. The system according to any one of claims 1 to 8, wherein said target flow rate is in the range between about 3.3 liters per minute to about 7.5 liters per minute.
10. The system according to any one of claims 1 to 9, wherein said suction flow rate is greater than 0.5 liters per minute.
11. The system according to claim 10, wherein said suction flow rate is in the range between about 0.5 liters per minute to about 2.0 liters per minute.

Patentansprüche

1. Arteriensystem, umfassend ein System zum Austausch des Arterienflusses und eine Steuerung zur Verwendung bei einem Patienten mit einem Aorten- und Körperblutkreislaufsystem, wobei:

das System zum Austausch des Arterienflusses eine distale Teilanordnung umfasst, die konfiguriert ist, um in der Aorta des Patienten bei Verwendung des Systems zum Austausch des Arterienflusses untergebracht zu werden, wobei die distale Teilanordnung umfasst:

eine Perfusionslumenanordnung mit mindestens einem Perfusionsauslass und mit mindestens einer Perfusionsquelle verbind-

bar, wobei die Perfusionslumenanordnung konfiguriert ist, um dadurch einen Sollperforationsfluss in die Aorta mit einer Sollperforationsflussrate bereitzustellen, die durch eine übermäßige Perfusionsflussrate größer als eine nominelle Perfusionsflussrate ist, wobei der nominelle Perfusionsfluss ausreicht, um dem Körperblutkreislaufsystem des Patienten einen angemessenen Fluidfluss bereitzustellen;

und eine Sauglumenanordnung, die mindestens einen Saugeinlass aufweist und mit einer Saugquelle verbindbar ist, wobei die Sauglumenanordnung zum Bereitstellen eines Saugflusses aus der Aorta konfiguriert ist, wobei der Saugfluss eine Saugdurchflussrate aufweist;

wobei der distale Abschnitt konfiguriert ist, um eine Fluidverbindung zwischen mindestens einem der Perfusionsauslässe und mindestens einem der Saugeinlässe innerhalb der Aorta über eine Außenseite des distalen Abschnitts bereitzustellen, wenn das Arteriensystem verwendet wird;

wobei die Steuerung bei der Verwendung des Arteriensystems konfiguriert ist zum:

selektiven steuerbaren Bereitstellen eines Sollperforationsflusses in die Aorta mit der Sollperforationsflussrate;

selektiven steuerbaren Bereitstellen eines Saugflusses aus der Aorta mit der Saugflussrate; und

selektiven gleichzeitigen Steuern der Sollperforationsflussrate und der Saugflussrate, um zu bewirken, dass Embolieschutt, der in der Aorta vorhanden sein kann, zu dem mindestens einen Saugeinlass abgeleitet wird.

2. System nach Anspruch 1, wobei die Steuerung zum selektiven Steuern der Sollperforationsflussrate und der Saugflussrate konfiguriert ist, um ein Rezirkulationsflussfeld zwischen mindestens einem Perfusionsauslass und mindestens einem Saugeinlass innerhalb der Aorta zu erzeugen, um zu bewirken, dass Embolieschutt, der in der Aorta vorhanden sein kann, zu dem jeweiligen mindestens einen Saugeinlass abgeleitet wird.

3. System nach Anspruch 1 oder Anspruch 2, wobei die Saugflussrate ein Anteil der nominellen Perfusionsflussrate ist, wobei der Anteil nicht weniger als etwa 10% der nominellen Perfusionsflussrate ist.

4. System nach einem der Ansprüche 1 bis 3, wobei das Arterienfluss-Austauschsystem in einer Arteri-

envorrichtung ausgeführt wird und die distale Teilanordnung einen distalen Teil der Arterienvorrichtung bildet und konfiguriert ist, um in der Aorta untergebracht zu werden, wobei die Arterienvorrichtung in Form einer Aortakanüle vorliegt, wobei der distale Abschnitt konfiguriert ist, um über eine Wand der aufsteigenden Aorta in die Aorta eingeführt zu werden.

5. System nach Anspruch 4, wobei der distale Abschnitt einen gekrümmten Abschnitt und ein distales Ende umfasst, wobei das distale Ende den mindestens einen Perfusionsauslass umfasst und wobei der gekrümmte Abschnitt den mindestens einen Saugeinlass umfasst.

6. System nach Anspruch 4 oder Anspruch 5, wobei die Perfusionslumenanordnung ein erstes Lumen umfasst, wobei die Sauglumenanordnung ein zweites Lumen umfasst und wobei das erste Lumen und das zweite Lumen einstückig in dem distalen Abschnitt ausgebildet sind, wobei das erste Lumen einen ersten Durchflussquerschnitt und das zweite Lumen einen zweiten Durchflussquerschnitt aufweist, wobei ein Durchflussquerschnittsverhältnis zwischen dem ersten Durchflussquerschnitt und dem zweiten Durchflussquerschnitt nicht weniger als etwa 1,10 beträgt.

7. System nach Anspruch 6, wobei das Querschnittsverhältnis zwischen etwa 1,10 und etwa 10,0 beträgt.

8. System nach Anspruch 4, wobei die Arterienvorrichtung in Form eines Aortenkatheters vorliegt, wobei der distale Abschnitt konfiguriert ist, um in die Aorta über einen Eintrittspunkt an einer Stelle stromabwärts der absteigenden Aorta eingeführt zu werden, wobei der distale Abschnitt weiter konfiguriert ist, um stromaufwärts zu der aufsteigenden Aorta geführt zu werden.

9. System nach einem der Ansprüche 1 bis 8, wobei die Solldurchflussrate im Bereich zwischen etwa 3,3 Litern pro Minute und etwa 7,5 Litern pro Minute beträgt.

10. System nach einem der Ansprüche 1 bis 9, wobei die Saugdurchflussrate größer als 0,5 Liter pro Minute ist.

11. System nach Anspruch 10, wobei die Saugdurchflussrate im Bereich zwischen etwa 0,5 Litern pro Minute und etwa 2,0 Litern pro Minute beträgt.

Revendications

1. Système artériel comprenant un système d'échange

d'écoulement artériel et un dispositif de commande pour utilisation avec un patient ayant une aorte et un système de circulation de sang corporel, dans lequel :

ledit système d'échange d'écoulement artériel comprend un agencement de partie distale configuré pour être reçu dans l'aorte du patient lors de l'utilisation du système d'échange d'écoulement artériel, ledit agencement de partie distale comprenant :

un agencement de lumière de perfusion ayant au moins une sortie de perfusion et pouvant se raccorder à au moins une source de perfusion, ledit agencement de lumière de perfusion étant configuré pour fournir à travers celui-ci un écoulement de perfusion cible dans l'aorte ayant un débit de perfusion cible qui est supérieur à un débit de perfusion nominal d'un débit de perfusion excédentaire, dans lequel ledit écoulement de perfusion nominal est suffisant pour fournir un écoulement de fluide adéquat au système de circulation de sang corporel du patient ;

et

un agencement de lumière d'aspiration ayant au moins une entrée d'aspiration et qui peut être raccordé à une source d'aspiration, ledit agencement de lumière d'aspiration étant configuré pour fournir un écoulement d'aspiration venant de l'aorte, ledit écoulement d'aspiration ayant un débit d'aspiration ;

ladite partie distale étant configurée pour fournir une communication fluïdique entre au moins une dite sortie de perfusion et au moins une dite entrée d'aspiration dans l'aorte via l'extérieur de ladite partie distale lors de l'utilisation du système artériel ;

ledit dispositif de commande étant configuré lors de l'utilisation du système artériel pour :

fournir par commande sélective un écoulement de perfusion cible dans l'aorte audit débit de perfusion cible ;

fournir par commande sélective un écoulement d'aspiration venant de l'aorte audit débit d'aspiration ; et

commander de manière sélective ledit débit de perfusion cible et ledit débit d'aspiration de manière simultanée pour amener les débris emboliques qui peuvent être présents dans l'aorte à être déviés vers ladite au moins une entrée d'aspiration.

2. Système selon la revendication 1, dans lequel ledit dispositif de commande est configuré pour commander sélectivement ledit débit de perfusion cible et ledit débit d'aspiration afin d'établir un champ d'écoulement de recirculation entre au moins une dite sortie de perfusion et au moins une dite entrée d'aspiration dans l'aorte afin d'amener les débris emboliques qui peuvent être présents dans l'aorte à être déviés vers au moins une dite entrée d'aspiration respective.

3. Système selon la revendication 1 ou la revendication 2, dans lequel ledit débit d'aspiration est une proportion d'un dit débit de perfusion nominal, dans lequel ladite proportion n'est pas inférieure à environ 10 % dudit débit de perfusion nominal.

4. Système selon l'une quelconque des revendications 1 à 3, dans lequel ledit système d'échange d'écoulement artériel est mis en oeuvre dans un dispositif artériel et ledit agencement de partie distale constitue une partie distale dudit dispositif artériel et est configuré pour être reçu dans l'aorte, dans lequel ledit dispositif artériel se présente sous la forme d'une canule aortique, dans lequel ladite partie distale est configurée pour être introduite dans l'aorte via une paroi de l'aorte ascendante.

5. Système selon la revendication 4, dans lequel ladite partie distale comprend une partie incurvée et une extrémité distale, dans lequel ladite extrémité distale comprend ladite au moins une sortie de perfusion et dans lequel ladite partie incurvée comprend ladite au moins une entrée d'aspiration.

6. Système selon la revendication 4 ou la revendication 5, dans lequel ledit agencement de lumière de perfusion comprend une première lumière, dans lequel ledit agencement de lumière d'aspiration comprend une seconde lumière et dans lequel ladite première lumière et ladite seconde lumière sont formées d'un seul tenant dans ladite partie distale, dans lequel ladite première lumière a une première section transversale d'écoulement et ladite seconde lumière a une seconde section transversale d'écoulement, dans lequel un rapport de sections transversales entre ladite première section transversale d'écoulement et ladite seconde section transversale d'écoulement n'est pas inférieure à environ 1,10.

7. Système selon la revendication 6, dans lequel ledit rapport de sections transversales se situe entre environ 1,10 et environ 10,0.

8. Système selon la revendication 4, dans lequel ledit dispositif artériel se présente sous la forme d'un cathéter aortique, dans lequel ladite partie distale est configurée pour être introduite dans l'aorte via un

point d'entrée à un emplacement en aval de l'aorte descendante, la partie distale étant en outre configurée pour naviguer en amont de l'aorte ascendante.

9. Système selon l'une quelconque des revendications 1 à 8, dans lequel ledit débit cible se situe dans la plage comprise entre environ 3,3 litres par minute et environ 7,5 litres par minute. 5
10. Système selon l'une quelconque des revendications 1 à 9, dans lequel ledit débit d'aspiration est supérieur à 0,5 litre par minute. 10
11. Système selon la revendication 10, dans lequel ledit débit d'aspiration se situe dans la plage comprise entre environ 0,5 litre par minute et environ 2,0 litres par minute. 15

20

25

30

35

40

45

50

55

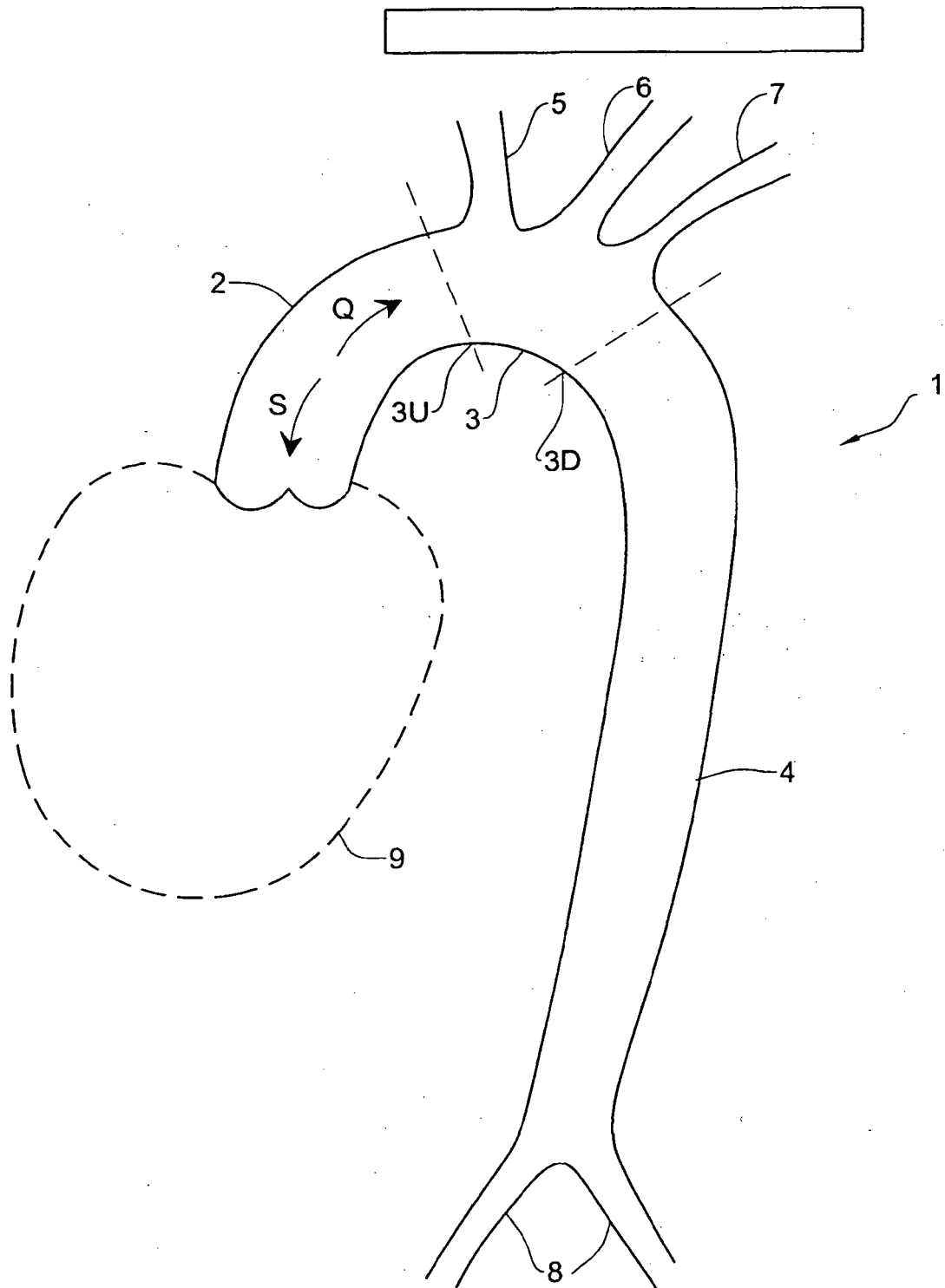

FIG. 1

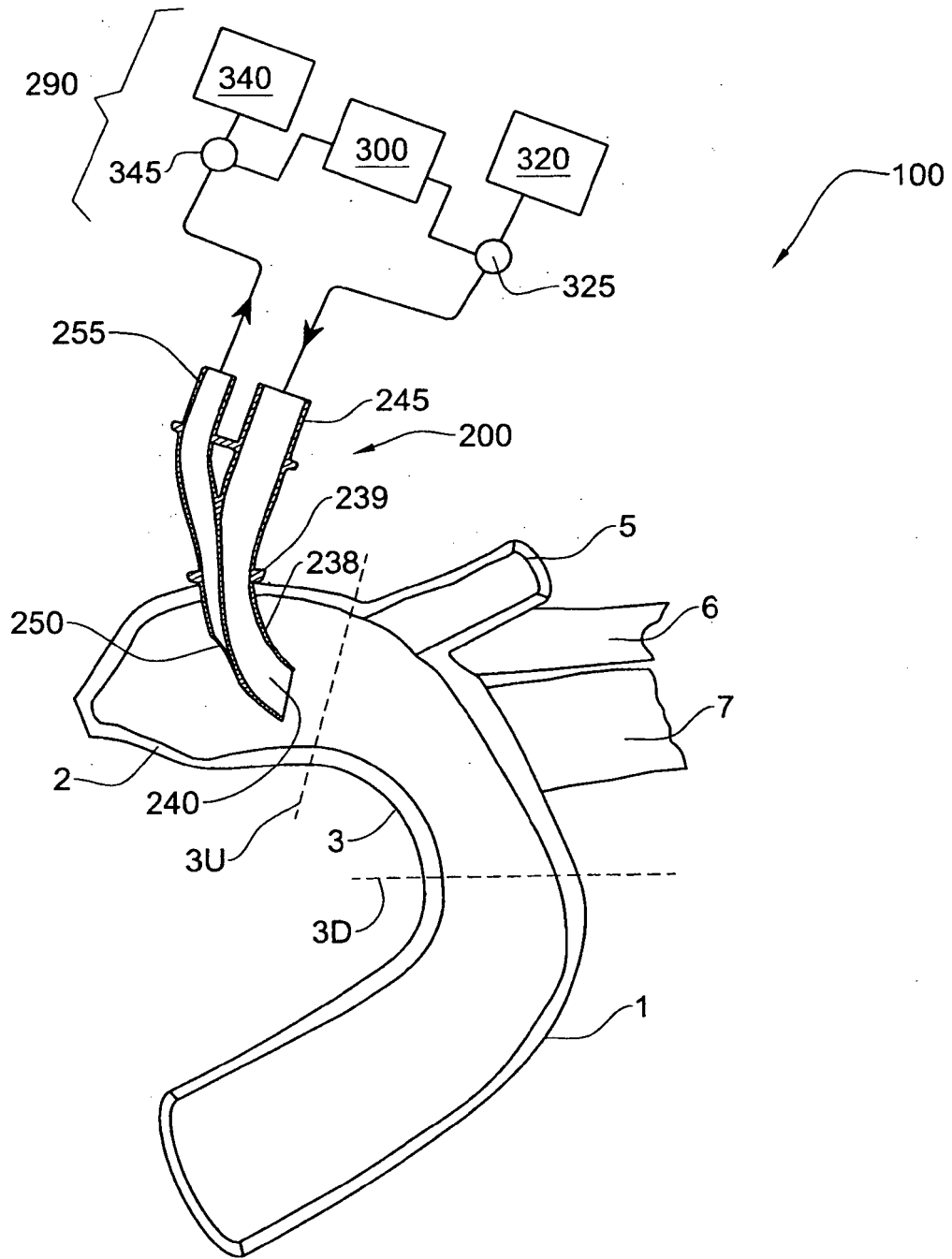

FIG. 2

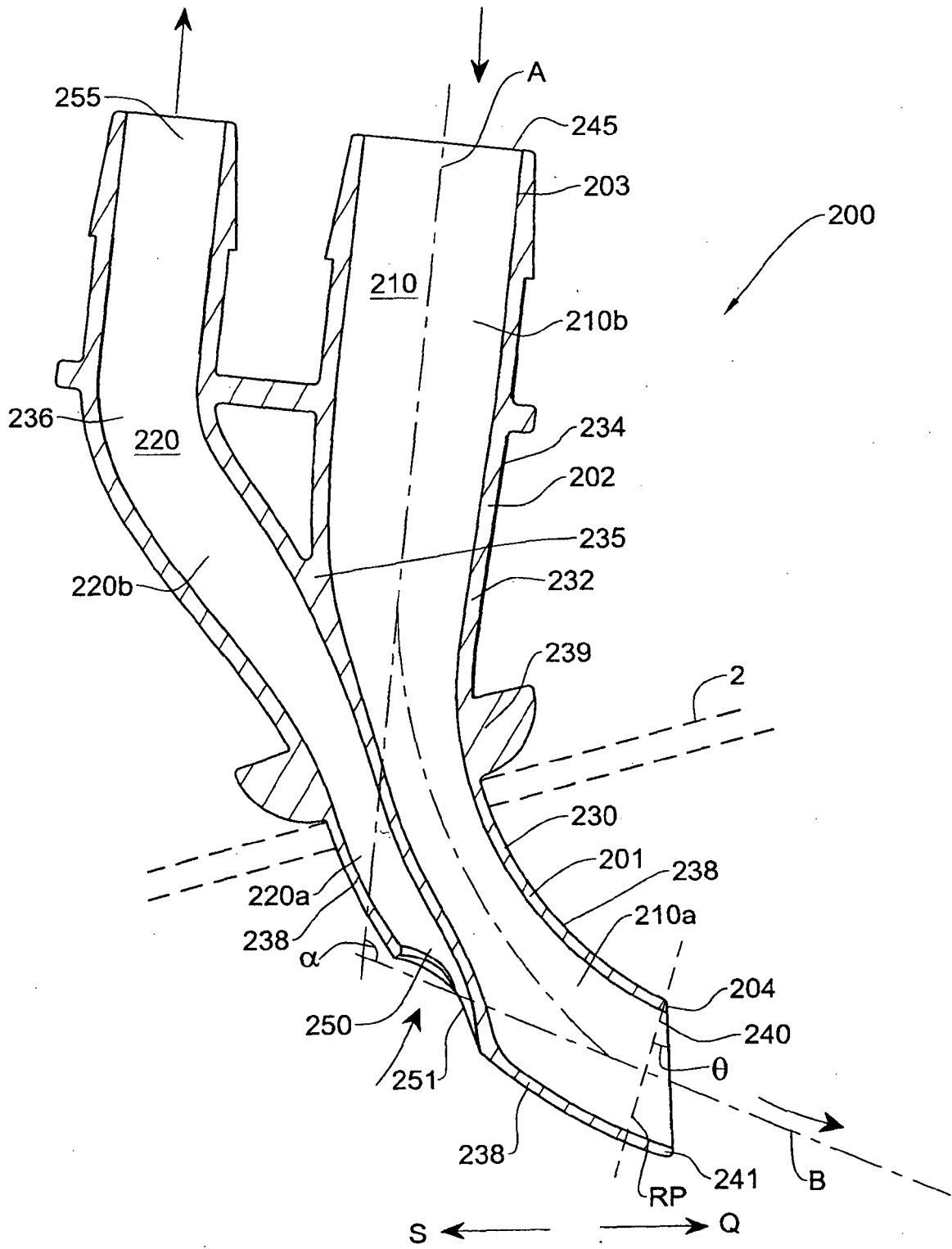

FIG. 3

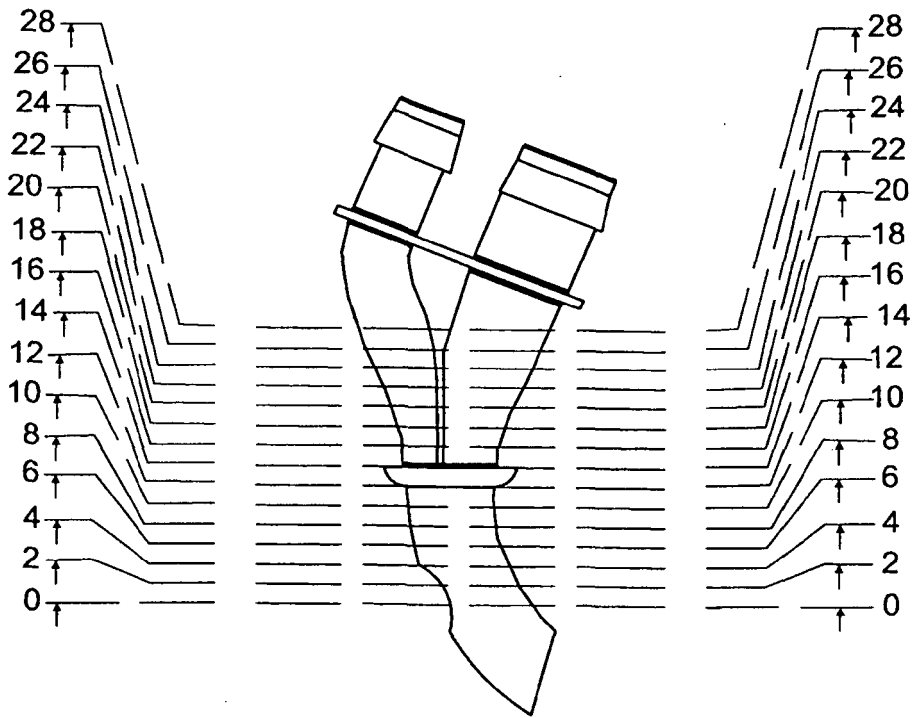
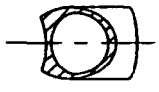
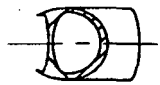

FIG. 4



SECTION 0-0
FIG. 4a



SECTION 2-2
FIG. 4b

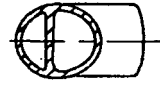

SECTION 4-4
FIG. 4c

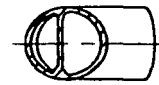

SECTION 6-6
FIG. 4c

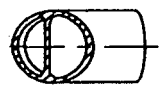

SECTION 8-8
FIG. 4d

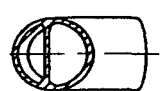

SECTION 10-10
FIG. 4e

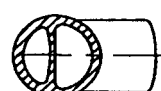

SECTION 12-12
FIG. 4f



SECTION 14-14
FIG. 4f

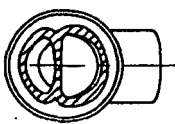

SECTION 16-16
FIG. 4g

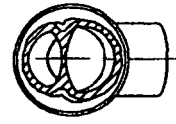

SECTION 18-18
FIG. 4h

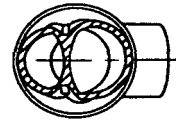

SECTION 20-20
FIG. 4i

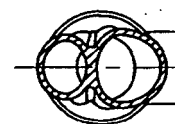

SECTION 22-22
FIG. 4j

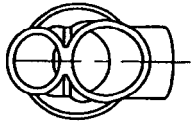

SECTION 24-24
FIG. 4k

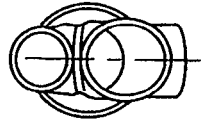

SECTION 26-26
FIG. 4l

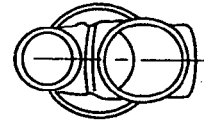

SECTION 28-28
FIG. 4m

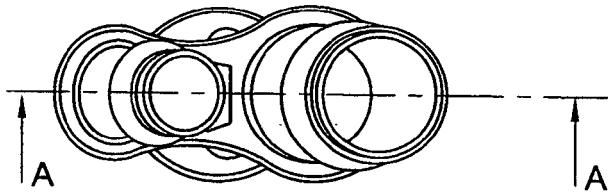
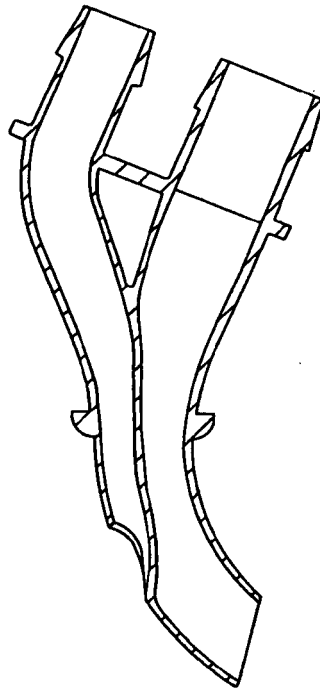

FIG. 4n



SECTION A-A

FIG. 4o

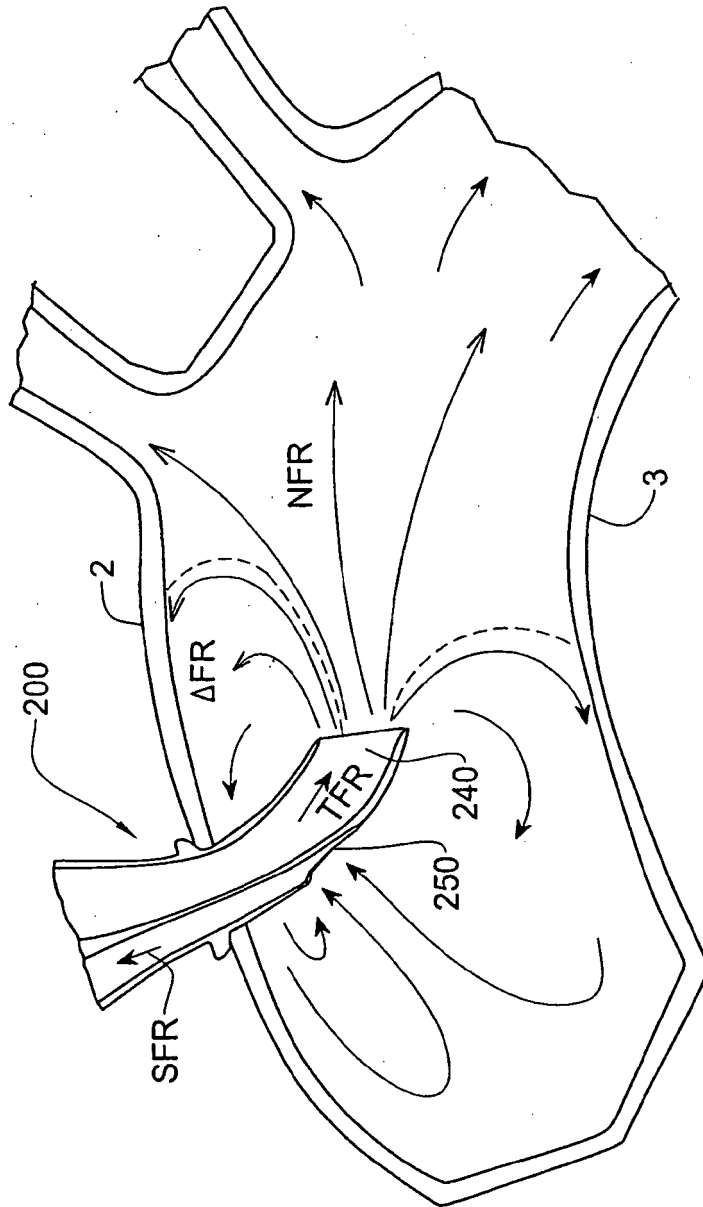

FIG. 5

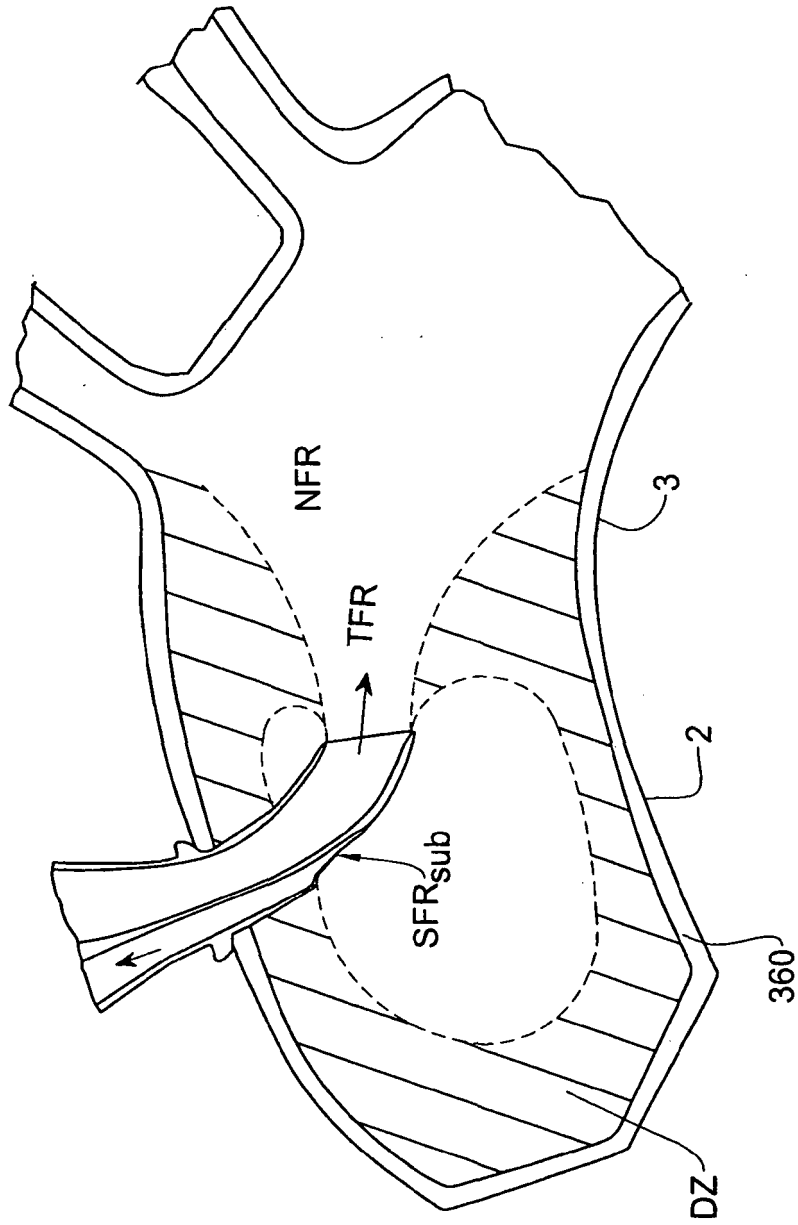

FIG. 6

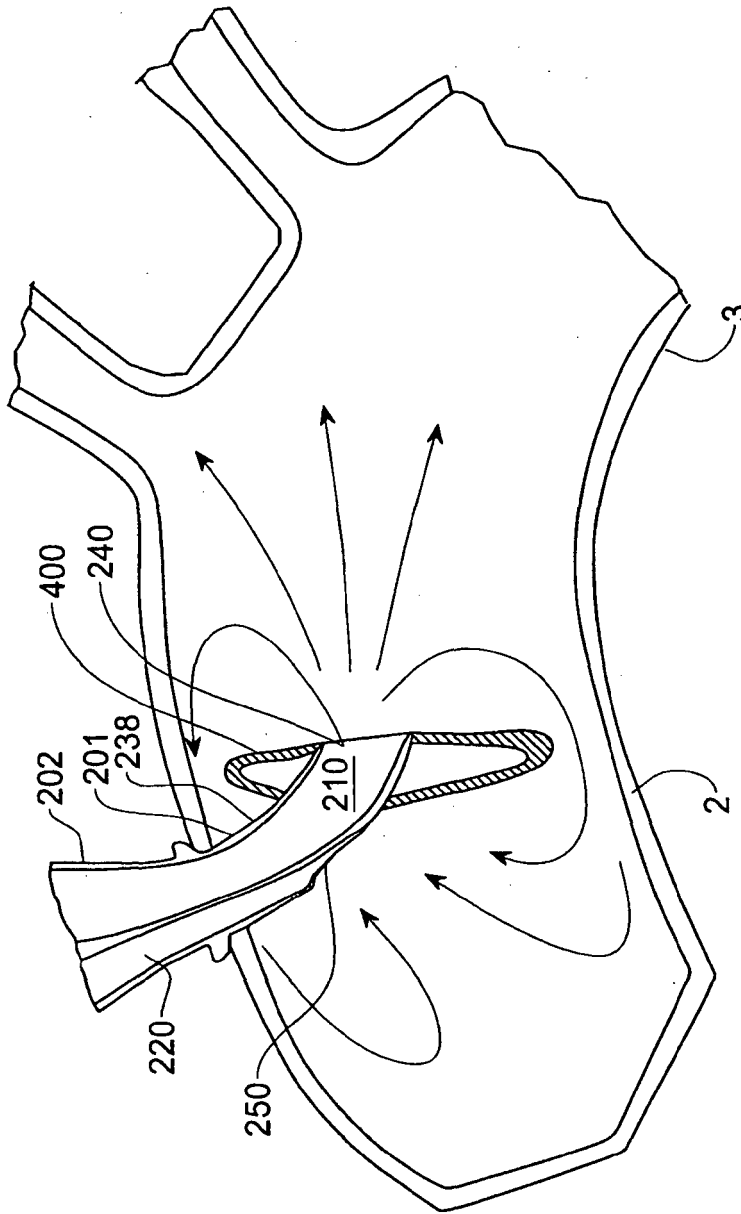

FIG. 8

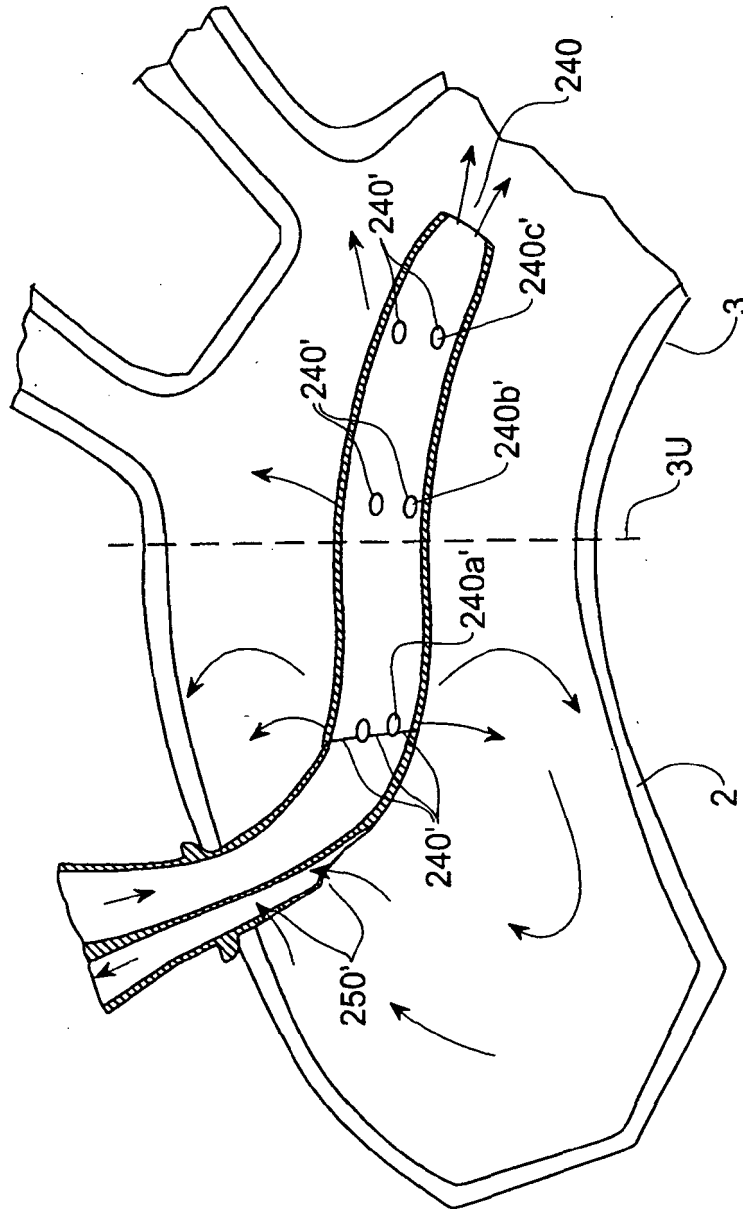

FIG. 9

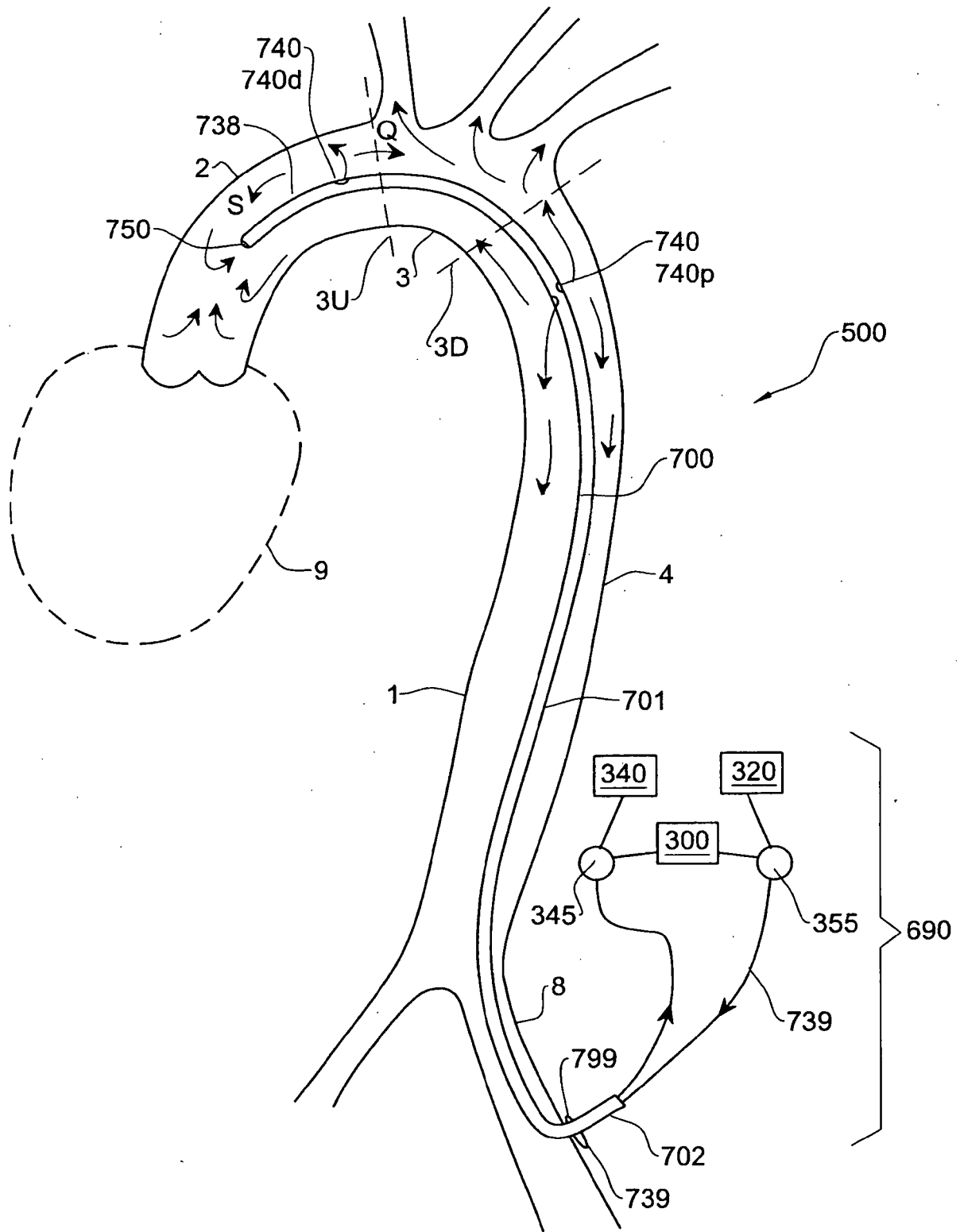

FIG. 10

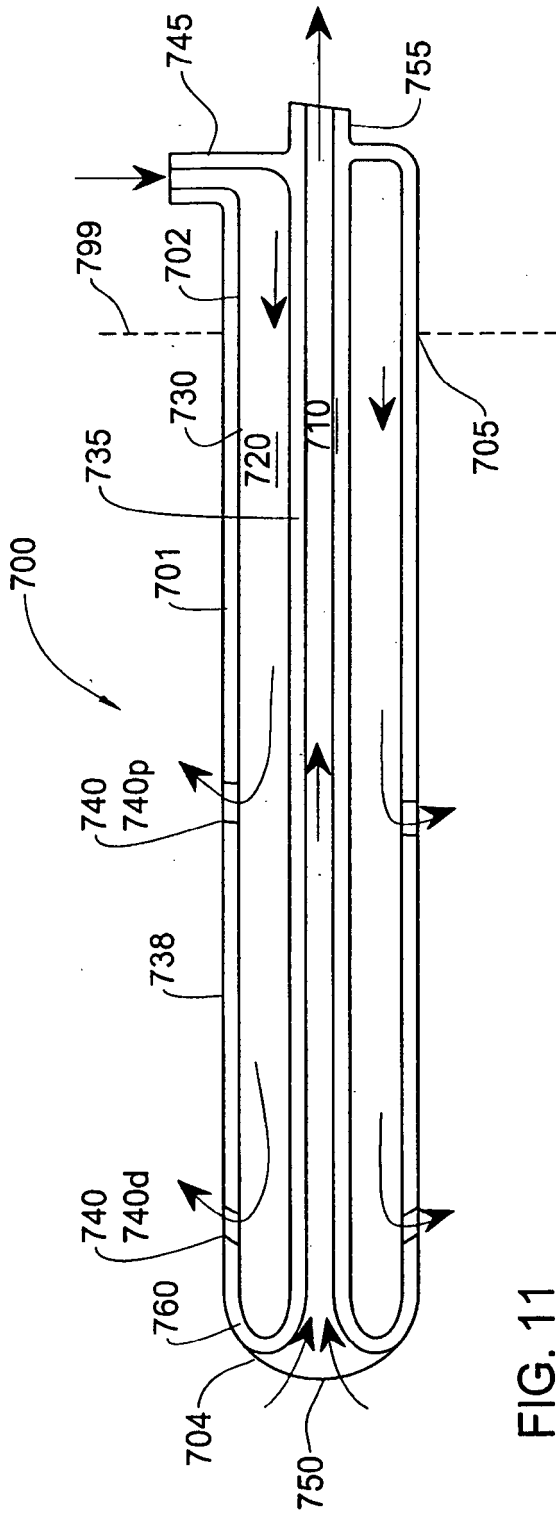

FIG. 11

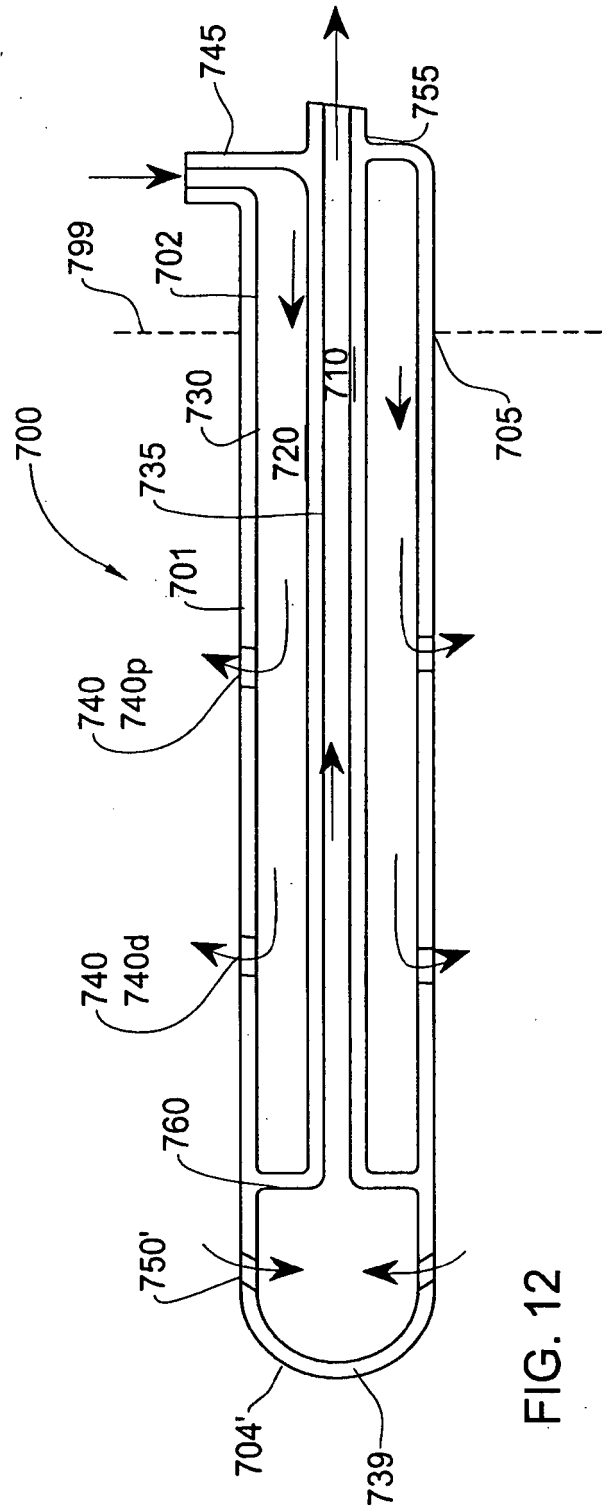

FIG. 12

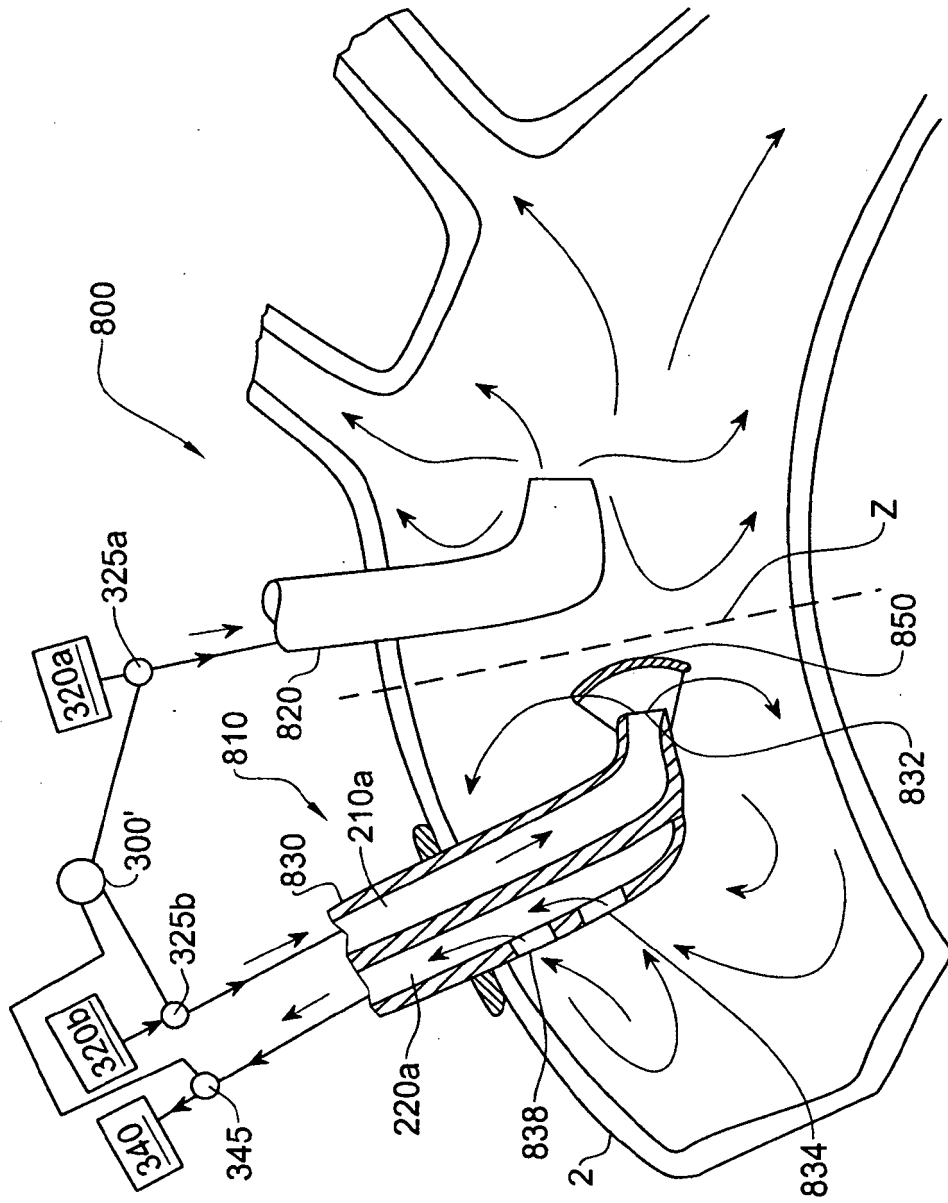

FIG. 13

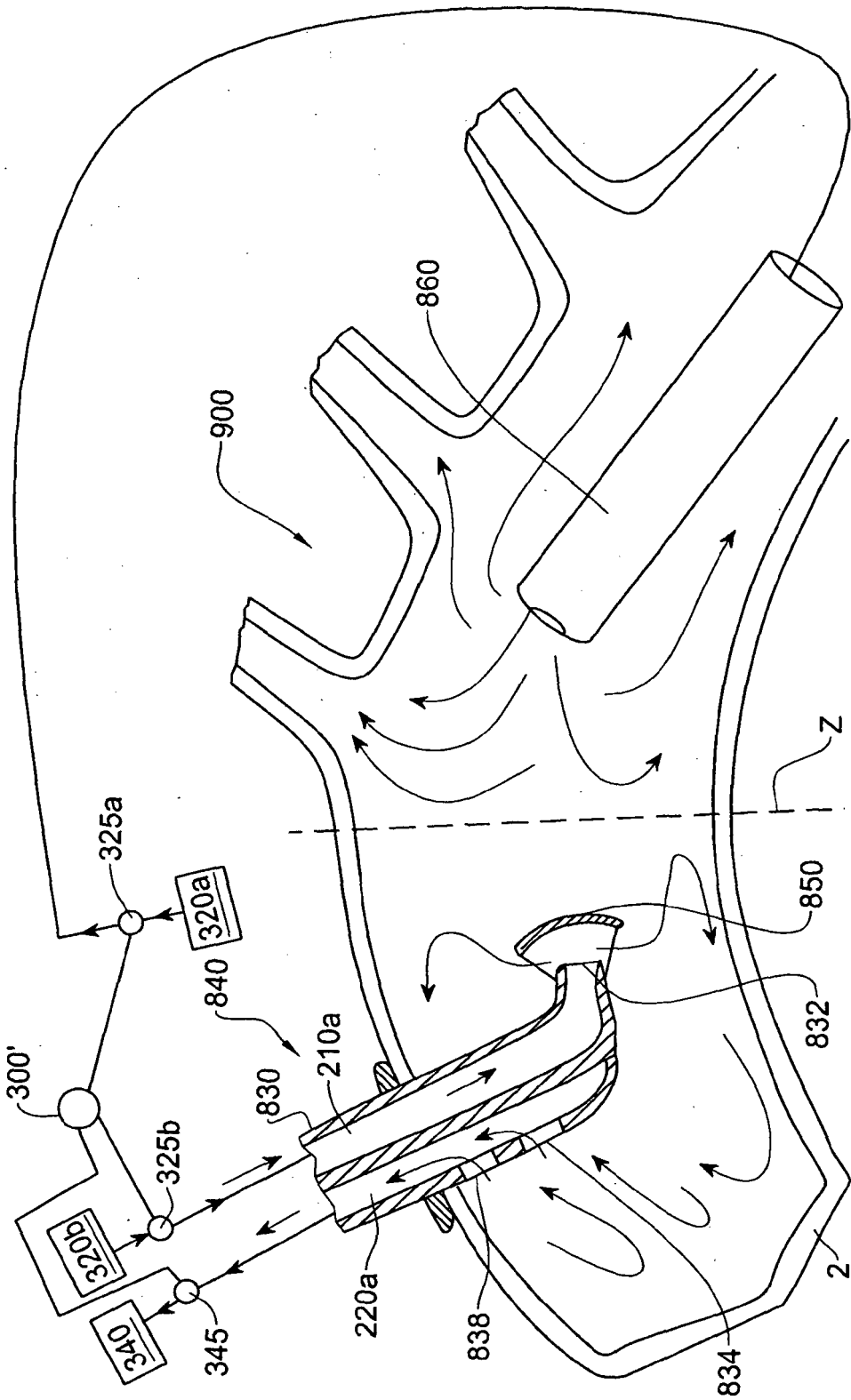

FIG. 14

REFERENCES CITED IN THE DESCRIPTION

This list of references cited by the applicant is for the reader's convenience only. It does not form part of the European patent document. Even though great care has been taken in compiling the references, errors or omissions cannot be excluded and the EPO disclaims all liability in this regard.

Patent documents cited in the description

- US 20030221561 A [0001]
- US 6689149 B [0003]
- US 6726651 B [0004]
- US 5697905 A [0005]
- US 7470363 B [0006]
- US 5425724 A [0007]