

(19)



(11)

**EP 2 025 854 A2**

(12)

**EUROPEAN PATENT APPLICATION**

(43) Date of publication:  
**18.02.2009 Bulletin 2009/08**

(51) Int Cl.:  
**E06B 3/46 (2006.01)**

(21) Application number: **08161360.6**

(22) Date of filing: **29.07.2008**

(84) Designated Contracting States:  
**AT BE BG CH CY CZ DE DK EE ES FI FR GB GR  
HR HU IE IS IT LI LT LU LV MC MT NL NO PL PT  
RO SE SI SK TR**  
Designated Extension States:  
**AL BA MK RS**

(71) Applicant: **Esposito, Pietro**  
**20129 Milan (IT)**

(72) Inventor: **Esposito, Pietro**  
**20129 Milan (IT)**

(30) Priority: **31.07.2007 IT MI20071572**

(74) Representative: **Fusina, Gerolamo et al**  
**Ing. Barzanò & Zanardo Milano S.p.A,**  
**Via Borgonuovo, 10**  
**20121 Milano (IT)**

**(54) Flush closing sliding door arranged in a pocket in the wall**

(57) Sliding door (10) for a fixed structure (13) provided with at least one opening (14). In the fixed structure (13) two panels (11) are foreseen that can slide between a first open position and a second closed position of the opening (14). Each of the panels (11) is provided with at least one sliding and guide element (22a,22b). The sliding and guide elements (22a,22b) are forced to slide inside rails (23,24) consisting of a first linear portion (23a, 24a) parallel to the main extension of the fixed structure (13) and a second curved portion (23b,24b).

Fig. 8

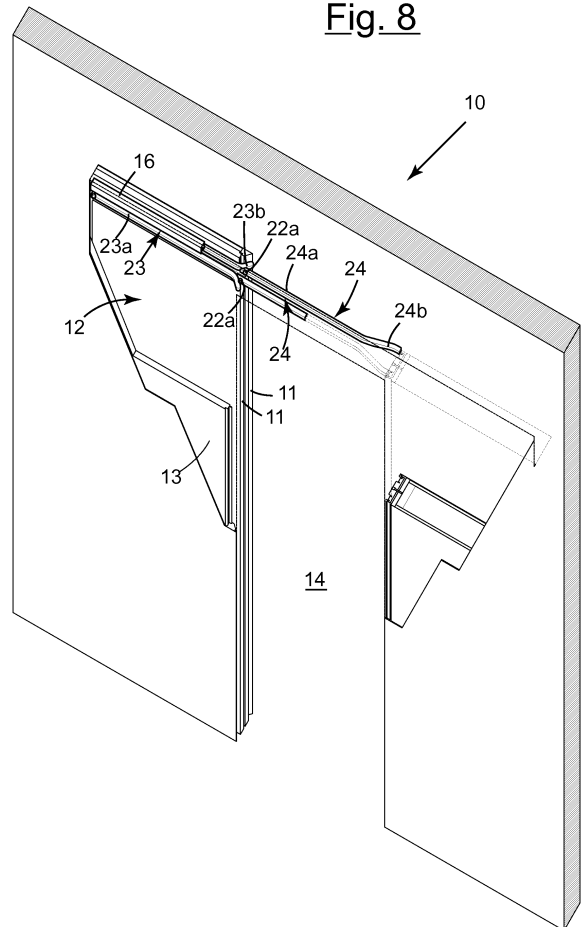

**EP 2 025 854 A2**

## Description

**[0001]** The present invention refers to a sliding door of the foldaway type, able to be aligned to close in a coplanar manner with a fixed structure.

**[0002]** Foldaway sliding doors currently known generally comprise a fixed structure, like for example a frame, provided at least with a containment body and with an opening, in which a panel is free to slide between a first open position, in which the panel is housed in the containment body, and a second closed position, in which the panel is withdrawn from the containment body covering the opening of the fixed structure and thus closing it.

**[0003]** Preferably, the fixed structure is made in a wall close to an opening in the wall so that the containment body of the panel is inside the thickness of such a wall.

**[0004]** In known foldaway sliding doors, the movement of the panel between the open position and the closed position is generally permitted by a plurality of rectilinear guide rails applied to the top cross members of the frame at both the containment body and the opening, in which suitable elements fixedly connected to the panel are free to slide.

**[0005]** Moreover, at the base of the containment body, guide elements are foreseen that cooperate with the base of the panel, in order to direct the movement thereof along a predetermined trajectory.

**[0006]** Such sliding and guide elements are generally arranged so as to be hidden from view in order to keep the wall in which the door is integrated looking good.

**[0007]** In particular, in known foldaway sliding doors, the panel is mobile along a rectilinear path, parallel to the main extension of the fixed structure to which it is fixedly connected, and arranged centrally with respect to the thickness of the fixed structure.

**[0008]** For this reason and because the panel has a smaller thickness than the fixed structure in order to be able to be housed in the containment body thereof, in its extracted closed position the panel is in withdrawn position with respect to the edges of both sides of the fixed structure. In the case in which, for example, the fixed structure is integrated into a wall, such an arrangement of the panel with respect to the edges of the wall disadvantageously creates a discontinuity in the overall appearance of both sides of the wall thus highlighting the presence of the door.

**[0009]** Moreover, known foldaway sliding doors are generally subject to oscillations during their movement deriving from the positioning of the means for controlling such movement and the relative constrictions mainly in the top part thereof.

**[0010]** The purpose of the present invention is to avoid the aforementioned drawbacks and in particular to make a sliding door of the foldaway type capable of ensuring the coplanarity thereof with both edges of the fixed structure in which it slides when it is in its closed position.

**[0011]** Another purpose of the present invention is to provide a sliding door of the foldaway type that is sub-

stantially without oscillations deriving from its movement.

**[0012]** A further purpose of the present invention is to make a sliding door of the foldaway type that is easy to install whilst still maintaining the aesthetic appearance of the doors currently on the market in which the movement and constriction elements of the door are substantially hidden from view.

**[0013]** These and other purposes according to the present invention are accomplished by making a sliding door of the foldaway type as outlined in claim 1.

**[0014]** Further characteristics of the device are the object of the dependent claims.

**[0015]** The characteristics and advantages of a sliding door of the foldaway type according to the present invention shall become clearer from the following description, given as a non-limiting example, referring to the attached schematic drawings, in which:

- figure 1a is an axonometric representation of the sliding door according to the present invention in closed position;
- figure 1b is an axonometric representation of the sliding door according to the present invention in open position;
- figure 2 is a schematic section view along the main sliding direction of the sliding door according to the present invention;
- figure 3 is an enlargement of a detail of figure 2;
- figure 4a is a section view along the line IVa-IVa of figure 2 when the foldaway sliding door according to the present invention is in extracted closed position;
- figure 4b is a section view along the line IVb-IVb of figure 2 when the foldaway sliding door according to the present invention is in open position;
- figure 5a is a schematic representation from above of the means for controlling the movement of the door according to the present invention in closed position;
- figure 5b is a schematic representation from above of the means for controlling the movement of the door according to the present invention in open position;
- figure 6a is a schematic representation from above of the guide rails of the door according to the present invention with the door in closed position;
- figure 6b is a schematic representation from above of the guide rails of the door according to the present invention with the door in open position;
- figure 7 is a perspective view of the motion transmission means used in the foldaway sliding door according to the present invention;
- figure 8 is an axonometric view, partially in section of the sliding door of the foldaway type according to the present invention.

**[0016]** With reference to the figures, a sliding door of the foldaway type is shown wholly indicated with 10.

**[0017]** The sliding door 10 according to the present

invention comprises a fixed structure 13 provided with at least one opening 14 and with two panels 11 free to slide between a first open position, in which such panels 11 do not cover the opening 14, and a second closed position, in which the panels 11 cover the opening 14, thus closing it.

**[0018]** Preferably, the fixed structure 13 comprises a containment body 12 made close to the opening 14, in which the panels 11 are housed when they are located in their open position and from which they are extracted when they are in their closed position.

**[0019]** The fixed structure 13 is for example made in a wall close to an opening thereof, so that the containment body 12 is inside the thickness of such a wall.

**[0020]** In the illustrated preferred but not limiting embodiment, the panels 11 are supported in suspension by at least one common sliding means 15, preferably two, like for example a trolley or a sliding block, free to slide along a rectilinear rail 16 fixedly connected to the top cross member 17 of the fixed structure 13 at the containment body 12 and the opening 14.

**[0021]** Such a rectilinear rail 16 is fixedly connected parallel to the main extension of the fixed structure 13 and is preferably positioned centrally with respect to the thickness of such a structure 13.

**[0022]** The panels 11 are fixedly connected to the common sliding means 15 through two arms 18 free to rotate about a common axis A passing through the sliding trajectory of the suitable common means 15, which, as well as transmitting the rectilinear sliding movement of such a common means 15 to the panels 11, allow the panels 11 to move towards one another and apart.

**[0023]** Preferably, but not exclusively, the arms 18 are fixedly connected to the common sliding means 15 through a central pin 19 provided with a bearing 20. It is also foreseen to arrange suitable washers 21 between the arms 18 in order to reduce the friction during the rotation of the arms 18.

**[0024]** In order to guide the panels 11 both in their rectilinear sliding movement, and in their movement towards one another and apart, each panel 11 has at least one sliding and guide element 22a,22b, for example a pair of pins provided on top with a suitable roller or sliding block, arranged on top and forced to slide in suitable second rails 23,24.

**[0025]** In an alternative embodiment that has not been illustrated, such sliding and guide elements 22a,22b can also act as a support in suspension of the panels 11. In such an embodiment, there are not therefore the common sliding means 15, as well as the elements 18 that fixedly connect the panels 11 to such sliding means 15.

**[0026]** The sliding and guide elements 22a,22b are preferably positioned on the panels 11 at the front and back with respect to the main sliding closed direction B of the door 10.

**[0027]** The front sliding and guide elements 22a of the two panels 11, are free to slide each in a second rail 24 fixedly connected to the top cross member 17 of the fixed

structure 13 at the opening 14.

**[0028]** The second rails 24 associated with the opening 14 are arranged so as to form a first pair of rails 24 comprising a first rectilinear portion 24a parallel to the main extension of the fixed structure 13, and a second curvilinear portion 24b in which said second rails 24 diverge from one another respectively terminating substantially at the edge of one side of the fixed structure 13.

**[0029]** The rear sliding and guide elements 22b of the panels 11 are free to slide each in a second rail 23 fixedly connected to the top cross member 17 of the containment body 12 of the fixed structure 13.

**[0030]** The second rails 24 inside the body 12 are arranged so as to form a second pair of rails 23 also comprising a first rectilinear portion 23a parallel to the main extension of the fixed structure 13 and a second curvilinear portion 23b in which such second rails 23 diverge apart and substantially respectively terminate at the edge of one side of the fixed structure 13.

**[0031]** In particular, the curvilinear portion 23b of the second rails 23 inside the body 12 has a smaller bending radius than the curvilinear portion 24b of the second rails 24 associated with the opening 14.

**[0032]** The foldaway sliding door 10 according to the present invention advantageously has motion transmission means 30, suitable for transferring the movement towards one another and/or apart of the panels 11 from the top part thereof to the bottom part.

**[0033]** Such a provision improves the operation of the door 10 according to the present invention damping possible oscillations of the panels 11 deriving from the positioning of the means for controlling the movement of the door 15,18,22a,22b, and of the relative constraints 16,23,24 exclusively in the top part thereof.

**[0034]** In a preferred embodiment, the motion transmission means 30 comprise two pairs of plates 31a,32a, 31b,32b, in which the plates 31a,32a,31b,32b of each pair are fixedly connected to the ends of a shaft 33a,33b.

**[0035]** The two shafts 33a,33b provided at their ends with a plate 31a,32a,31b,32b are coaxial and free to rotate with respect to one another.

**[0036]** In particular, the plates 31a,31b or 32a,32b fixedly connected to the same top or bottom end of the two shafts 33a,33b are cross-connected to the inner walls of the panels 11, i.e. such plates 31a,31b or 32a,32b are fixedly connected respectively upstream of a first panel 11 and downstream of a second panel 11 and vice-versa.

**[0037]** Preferably, in the foldaway sliding door 10 according to the present invention a pair of motion transmission means 30 is used.

**[0038]** In order to simplify the assembly of the foldaway sliding door 10 according to the present invention, whilst still maintaining the appearance of the doors currently on the market in which the guide and constriction elements of the door are substantially hidden from view, the panels 11 consist of a bearing structure 40 provided with a plurality of fastening elements 41,42,43 for the respective attachment of the connection arms 18 to the common

sliding means 15, of the sliding and guide elements 22a, 22b and of the motion transmission means 30, and of a coating panel 44 having a greater extension than the bearing structure 40 and such as to hide the plurality of fastening elements 41,42,43 from view.

[0039] Moreover, the bearing structure 40 has projections 45 suitable for guiding the coating panel 44 into its correct positioning on the bearing structure 40.

[0040] Once correctly positioned, the coating panel 44 is kept in position by suitable locking means, for example snap means or pin and bushing 46.

[0041] The panels can in addition be mounted in position through a simple insertion operation of the sliding elements 22a,22b and possibly also of the common sliding means 15 in the relative rails 23,24 and 16, which for such a purpose are advantageously provided with suitable openings 25.

[0042] The operation of the foldaway sliding door 10 according to the present invention is the following.

[0043] When one of the two panels 11 is manually controlled to slide, for example in order to go from the open position to the closed position, the movement that it is given, substantially translational along a direction parallel to the main extension of the fixed structure 13, is also transmitted to the second panel 11 through the plates 31a,32a, 31b,32b connected as a bridge between the two panels 11 that maintains their fixed mutual positioning with respect to the main direction of translation of the door 10.

[0044] In the illustrated embodiment, such translation movement is also transmitted to the second panel 11 also through the common trolley 15.

[0045] The two panels 11 thus carry out a simultaneous movement.

[0046] The panels 11 are also guided by the second rails 23,24 that, in the portion in which such panels 11 slide inside the containment body 12, make them 11 translate rectilinearly, whereas at the opening 14 of the fixed structure 13, and more specifically at their curvilinear portions 23b,24b, they force such panels 11 to move apart, thus carrying out a translation both along the direction parallel to the main extension of the fixed structure 13, and along a direction perpendicular to it.

[0047] In particular, the translation along the perpendicular direction is sized so as to take the two panels 11 into alignment each with the respective edge of the side of the fixed structure 13 onto which it faces.

[0048] Vice-versa, when opening, the panels 11 are initially guided towards one another through a translation both along the direction parallel to the main extension of the fixed structure 13, and along a direction perpendicular to it, and then directed towards the inside of the containment body 12 through a purely rectilinear movement along the direction parallel to such a main extension.

[0049] The movements apart or towards one another of the two panels 11 that are given on top of them by the sliding of the relative sliding and guide elements 22a,22b in the curvilinear portions 23b,24b of the second rails

23,24, forces the top pairs of plates 31a,31b to open in a cross, or to align, respectively.

[0050] The respective opening and alignment movement of the top plates 31a,31b is transmitted through the respective shafts 33a,33b to the bottom plates 32a,32b that thus impose and also maintain the same distance at the bottom between the two panels 11.

[0051] Therefore, possible oscillation movements deriving from the delays in transmission of the motion from the top end of the panels 11 to the bottom end are damped.

[0052] From the description that has been made the characteristics of the foldaway sliding door object of the present invention are clear, just as the relative advantages are also clear.

[0053] Finally, it is clear that the foldaway sliding door thus conceived can undergo numerous modifications and variants, all of which are covered by the invention; moreover, all of the details can be replaced by technically equivalent elements.

[0054] In practice, the materials used, as well as the sizes, can be whatever according to the technical requirements.

## Claims

1. Sliding door (10) of the foldaway type comprising a fixed structure (13) provided with at least one opening (14), in said fixed structure (13) two panels (11) being foreseen able to slide between a first open position and a second closed position of said opening (14), each of said panels (11) being provided with at least one sliding and guide element (22a,22b), where said sliding and guide elements (22a,22b) are constrained to slide inside rails (23,24) consisting of a first rectilinear portion (23a,24a) parallel to the main extension of said fixed structure (13) and a second curvilinear portion (23b,24b).
2. Sliding door (10) of the foldaway type according to claim 1 **characterised in that** said rails (23,24) at their curvilinear portion (23b,24b) have a mutually diverging progression in pairs.
3. Sliding door (10) of the foldaway type according to claim 1 or 2 **characterised in that** each panel (11) is provided with two sliding and guide elements (22a, 22b) arranged on top of said panel (11), of which a first sliding and guide element (22a) is positioned at the front with respect to a main sliding closed direction (B) and is associated with a rail (24) fixedly connected to a top cross member (17) of said fixed structure (13) at said opening (14), and a second sliding and guide element (22b) is positioned at the back with respect to said main sliding closed direction (B) and is associated with a rail (23) fixedly connected to said top cross member (17) of said fixed structure

(13) at a containment body (12).

4. Sliding door (10) of the foldaway type according to claim 3 **characterised in that** the curvilinear portion (23b) of the rails (23) fixedly connected at said body (12) has a smaller bending radius than the curvilinear portion (24b) of the rails (24) fixedly connected at said opening (14). 5
5. Sliding door (10) of the foldaway type according to any one of claims 1 to 4 **characterised in that** it comprises motion transmission means (30) suitable for transferring the mutual approach and/or separation movement of said panels (11) from the top part thereof to the bottom part. 10 15
6. Sliding door (10) of the foldaway type according to claim 5 **characterised in that** said motion transmission means (30) comprise two pairs of plates (31a, 32a, 31b, 32b), in which the plates (31a, 32a, 31b, 32b) of each pair are fixedly connected to the ends of a shaft (33a, 33b), said shafts (33a, 33b) being coaxial and free to rotate with respect to one another. 20
7. Sliding door (10) of the foldaway type according to claim 6 **characterised in that** the plates (31a, 31b and 32a, 32b) fixedly connected to the same top or bottom end of said shafts (33a, 33b) are cross-connected to the inner walls of said panels (11). 25 30
8. Sliding door (10) of the foldaway type according to any one of the previous claims **characterised in that** said panels (11) are supported by at least one common sliding means (15) free to translate along a rectilinear direction. 35
9. Sliding door (10) of the foldaway type according to claim 8 **characterised in that** said common sliding means (15) is forced to translate inside a rectilinear rail (16) arranged centrally with respect to a thickness of said fixed structure (13). 40
10. Sliding door (10) of the foldaway type according to claim 8 or 9 **characterised in that** said panels (11) are connected to said common sliding means (15) through two arms (18) free to rotate about a common axis (A) passing through the sliding trajectory of said common sliding means (15). 45
11. Sliding door (10) of the foldaway type according to any one of the previous claims **characterised in that** said panels comprise a bearing structure (40) provided with a plurality of fastening elements (41, 42, 43), and a coating panel (44) having a longer extension than said bearing structure (40) and such as to hide said plurality of fastening elements (41, 42, 43) from view. 50 55

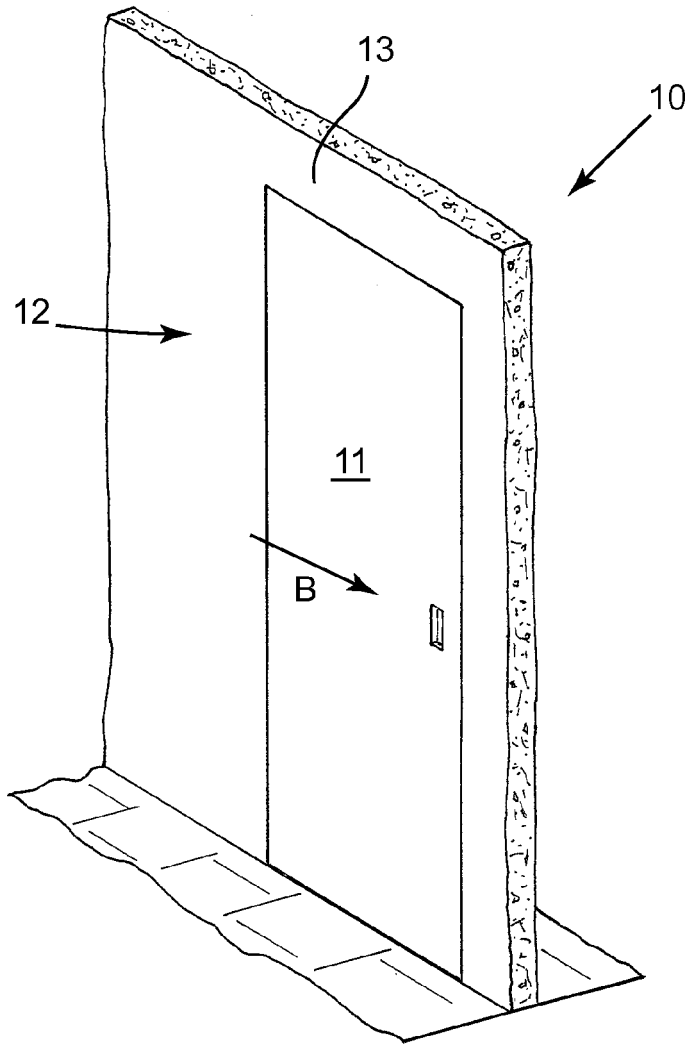

Fig. 1a

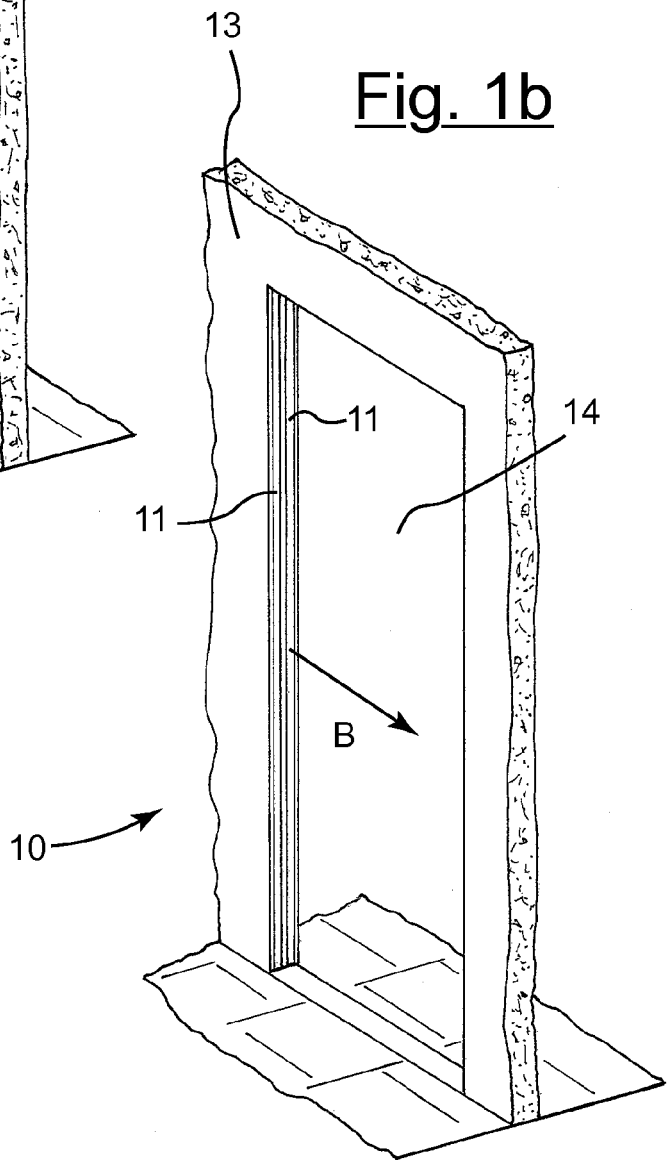

Fig. 1b

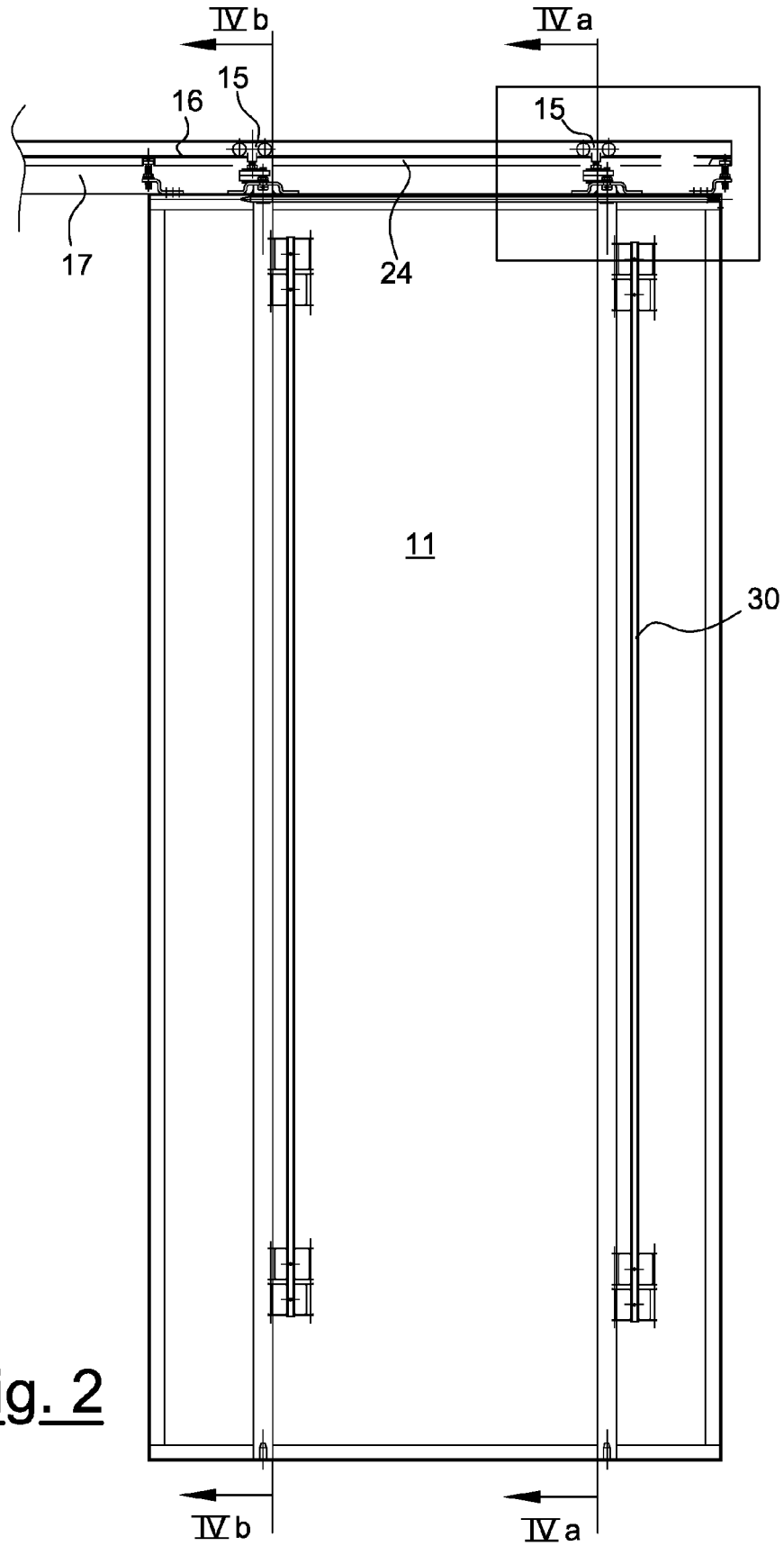

Fig. 2

Fig. 3

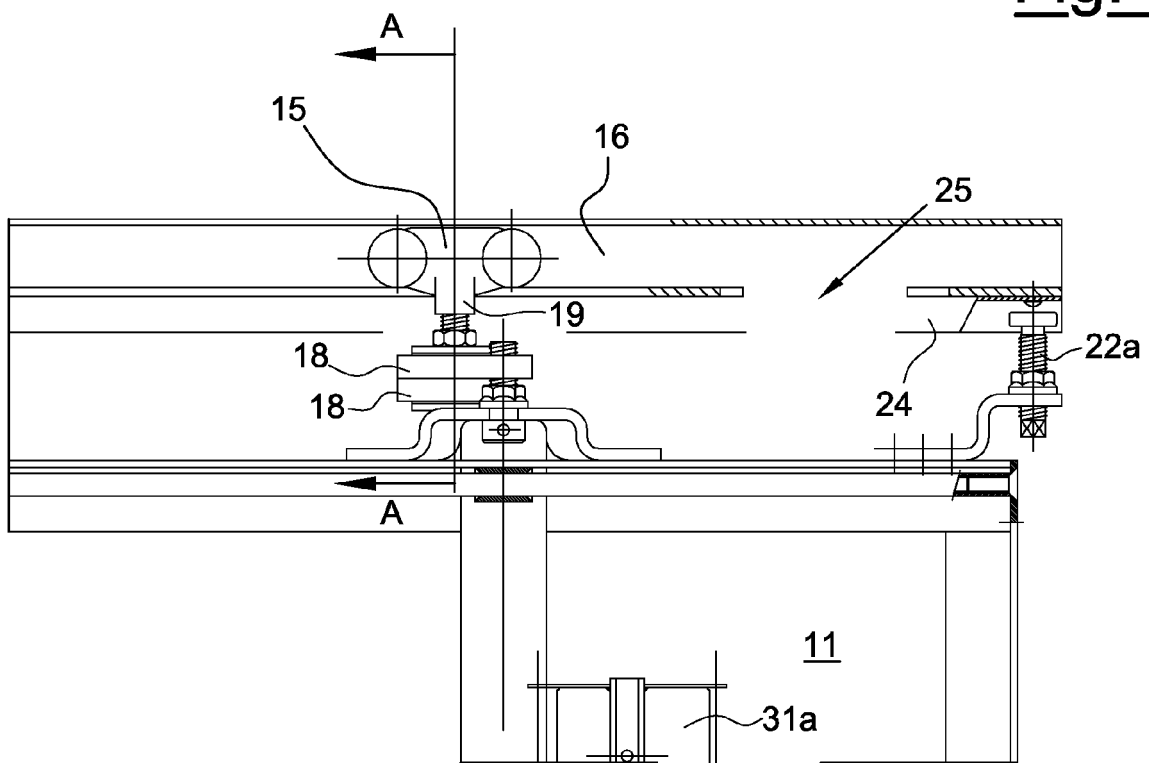



Fig. 4a

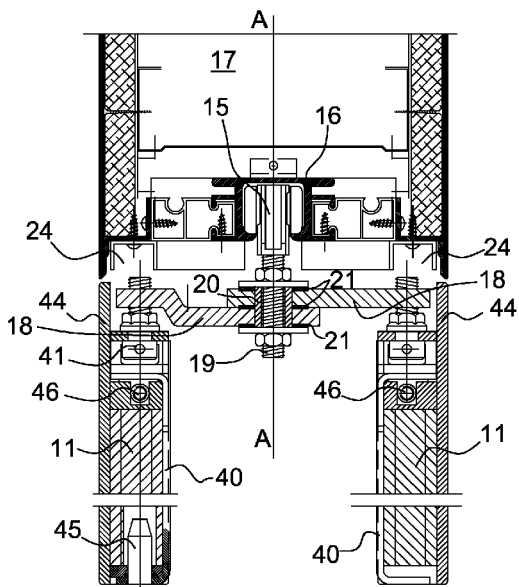

Fig. 4b

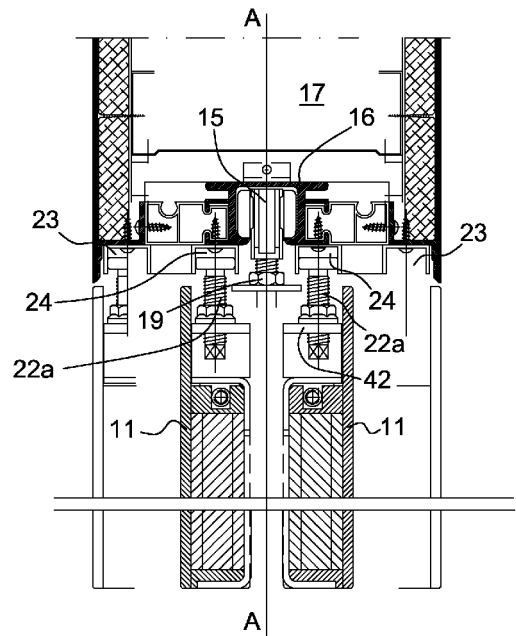

Fig. 5a

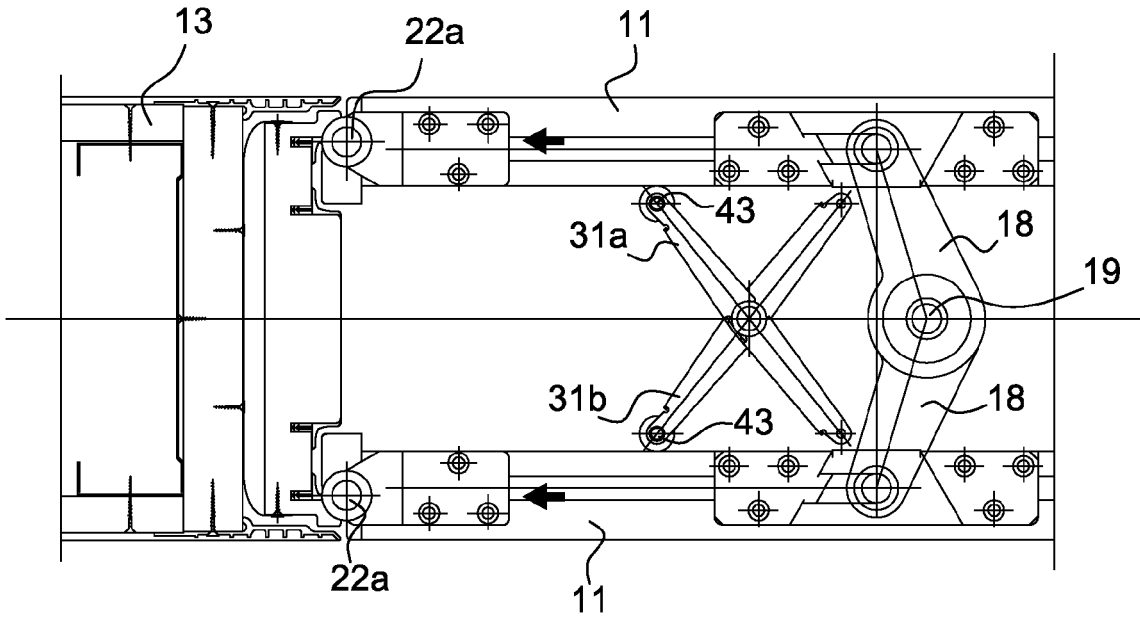
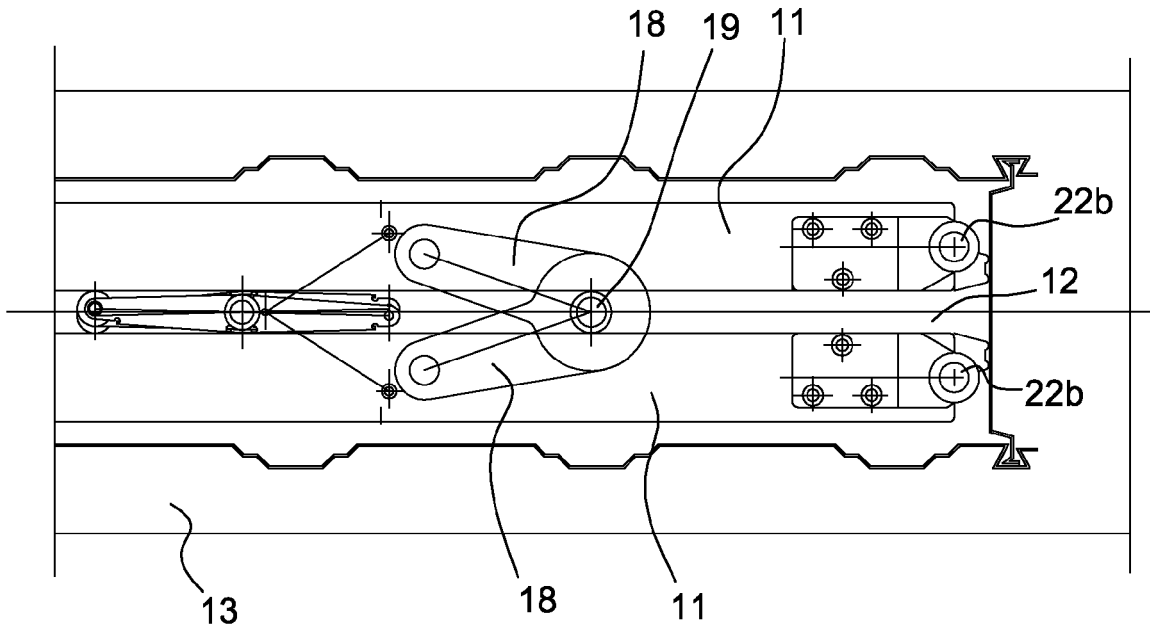
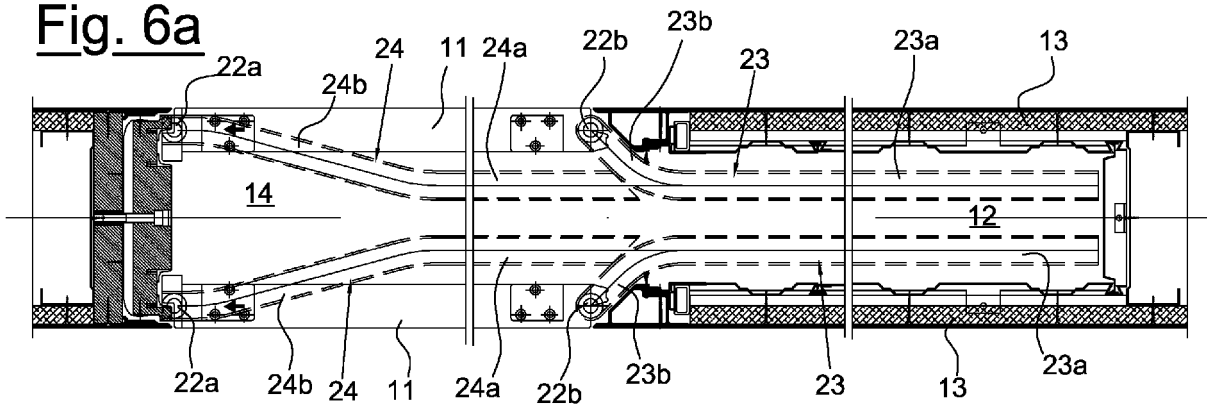

Fig. 5b



**Fig. 6a**



**Fig. 6b**

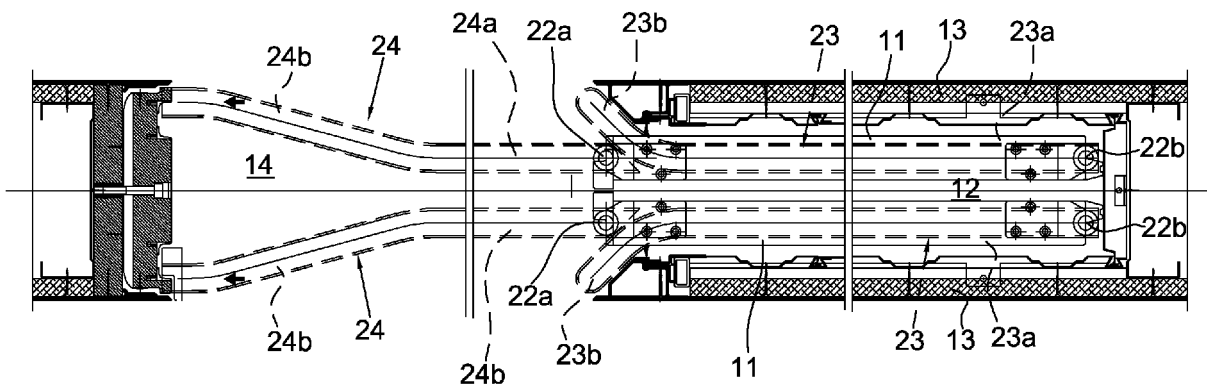

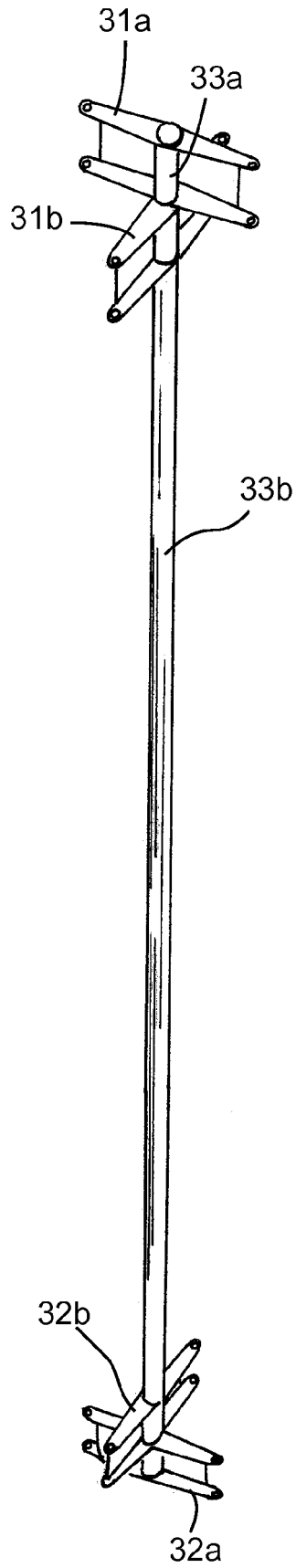

Fig. 7

Fig. 8

