



(11) **EP 2 775 460 A1**

(12) **EUROPEAN PATENT APPLICATION**

(43) Date of publication:
10.09.2014 Bulletin 2014/37

(51) Int Cl.:
G07D 9/00 (2006.01)

(21) Application number: **14157059.8**

(22) Date of filing: **27.02.2014**

(84) Designated Contracting States:
AL AT BE BG CH CY CZ DE DK EE ES FI FR GB GR HR HU IE IS IT LI LT LU LV MC MK MT NL NO PL PT RO RS SE SI SK SM TR
Designated Extension States:
BA ME

(72) Inventor: **Kurosawa, Motoharu**
Saitama-ken, Saitama (JP)

(74) Representative: **Prüfer & Partner GbR**
European Patent Attorneys
Sohnckestrasse 12
81479 München (DE)

(30) Priority: **08.03.2013 JP 2013046534**

(71) Applicant: **ASAHI SEIKO CO., LTD.**
Minato-ku
Tokyo 107-0062 (JP)

Remarks:

Amended claims in accordance with Rule 137(2) EPC.

(54) **Coin dispenser**

(57) An object of the present invention is to provide a coin dispenser capable of fixing a dispensing direction of coins even if the coins have different diameters.

Coins are dropped into through holes and sorted one by one by forward rotation of a rotating disk and are guided by a circular coin guiding wall of a storage hole while being pushed by pushers on a lower surface. Then, each of the coins is pushed into the part between a fixed roller and an ejecting roller and is smoothly subjected to change of direction to the circumferential direction of the rotating disk by the turning pair of the fixed roller. Then, in a state in which the coin is sandwiched by a fixed guide and the ejecting roller disposed in the downstream of the fixed roller and is in a sliding pair with the fixed guide, the coin is ejected by the ejecting roller. Therefore, inertial force in the contact point direction of the coin is eliminated, and the ejecting direction of the coins is practically fixed.

FIG.5

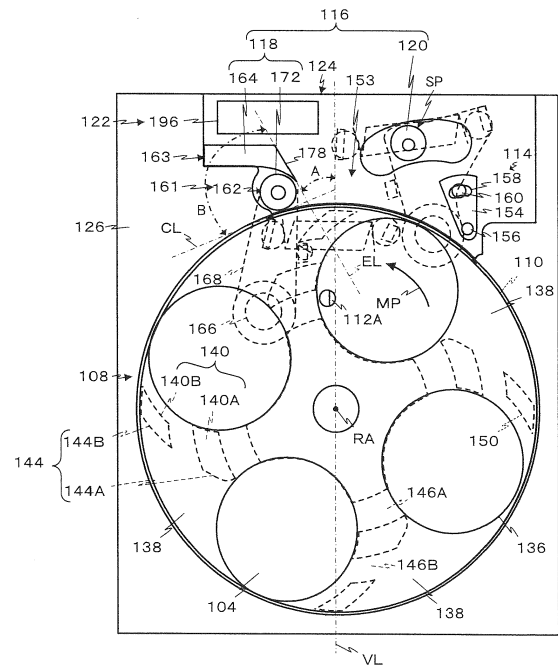

EP 2 775 460 A1

Description

BACKGROUND OF THE INVENTION

1. Field of the Invention

[0001] The present invention relates to a coin dispenser and particularly relates to a coin dispenser that can stabilize the dispensing direction of coins to a level that does not practically cause problems even when the diameters of the coins to be dispensed are different.

[0002] The "coins" used in the present specification include coins serving as money and tokens serving as money substitute such as medals.

2. Description of Related Art

[0003] As a coin dispenser that dispenses many coins, which are stored in bulk in a storing bowl, one by one by using a rotating disk disposed in a bottom hole of the storing bowl, there is a hopper device (for example, Japanese Unexamined Patent Application Publication No. 2002-150347) that elastically sandwiches, from the left and right, the circumferential surface of a coin by a fixed roller and an elastically-biased ejecting roller and ejects the coin as a first prior art. Moreover, as a second prior art, there is a coin hopper (for example, Japanese Unexamined Patent Application Publication No. 2010-262520) that sandwiches the coin between a fixed plate and an elastically-biased roller and ejects the coin.

[0004] Furthermore, as a third prior art, there is a disk releasing device (for example, Japanese Unexamined Patent Application Publication No. 2010-131122) that feeds disks one by one by a rotating disk, aligns the disks in a row in a guide passage, sandwiches the coin in the front by a fixed member and a movable member, which is provided to be swingable about a shaft serving as a pivot point and is attached to a lever biased in a predetermined direction by an elastic part, while sequentially pushing the disk in a front position by the disk in a rear position, and ejects it.

[0005] Recently, from the viewpoint of convenience, cost reduction, etc., coins having diameters in a predetermined range such as 1-yen coins, 5-yen coins, 10-yen coins, 50-yen coins, 100-yen coins, and 500-yen coins of Japanese coins are required to be dispensed by a coin dispenser having a single structure. In other words, the coins having diameters of 20 millimeters to 26.5 millimeters are required to be dispensed by a coin dispenser having a single structure.

[0006] However, if the above described first, second, and third prior arts are simply employed, there are various concerns, and they cannot be readily employed.

[0007] First, matters of concern in a case in which the first prior art is employed will be explained with reference to FIG. 1 and FIG. 2.

[0008] As shown in FIG. 1, a coin dispenser 10 has a rotating disk 12 and a base 16 disposed in the back side

of the rotating disk 12. In the rotating disk 12, a plurality of through holes 14, which are disposed at eccentric positions and penetrate therethrough from the front side toward the back side, are formed. The coin C (a small-diameter coin SC in FIG. 1) is dropped onto the base 16 through the through hole 14 by the rotation of the rotating disk 12. While the coin C, which has been dropped onto the base 16, is guided by a circular guiding wall 24 of a storage hole 22 in a state in which a surface thereof is in contact with the base 16, the coin is pushed by pushers 20 (a first pusher 20A and a second pusher) formed on the lower surface of a rib 18 between the through holes 14. As a result, the coin C on the base 16 is rotated together by the rotating disk 12 and reaches an outlet opening 26 of the storage hole 22. The coin C, which has reached the outlet opening 26, is guided by a guide plate 30 and brought into contact with an ejecting roller 32 or is guided by regulating pins 34 (a first regulating pin 34A and a second regulating pin 34B) and pushed into the part between a fixed roller 36 and the ejecting roller 32, and is sandwiched by the fixed roller 36 and the ejecting roller 32. When the coin C is pushed into the part between the fixed roller 36 and the ejecting roller 32, the coin C is a sliding pair with the fixed roller 36 and the ejecting roller 32, but the fixed roller 36 and the ejecting roller 32 are a turning pair; therefore, as the coin C is moved, the fixed roller 36 and the ejecting roller 32 are rotated, and the coin C is smoothly pushed thereinto against the biasing force caused by an elastic part (not shown) applied to the ejecting roller 32.

[0009] Then, immediately after the coin center CC of the coin C passes the straight line (for the sake of convenience, will be referred to as an ejection border line DDL) connecting a first contact point PA of the fixed roller 36 and the coin C and a second contact point PB of the ejecting roller 32 and the coin C, the coin is ejected by spring force caused by a spring (not shown) applied to the ejecting roller 32. The ejecting direction by the fixed roller 36 and the ejecting roller 32 is approximately in the vector direction of the resultant force F3 of the pushing force F1 from the first contact point PA toward the coin center SCC upon ejection and the reactive force F2 from the second contact point PB toward the coin center CC, but is the direction it has received working of inertial force F4 in the direction of rotation together by the rotating disk 12. More specifically, in the case of the small-diameter coin SC, the small-diameter ejecting direction SD is in the direction of the vector of the second resultant force F5 of the resultant force F3 and the inertial force F4.

[0010] Then, if the diameter of the coin C is different, for example in a case of a large-diameter coin LC in which the diameter of the coin C is large as shown in FIG. 2, since the weight of the coin is increased, the inertial force F4 is increased, and a large-diameter ejecting direction LD of the large-diameter coin LC is toward the fixed roller 36 side compared with the small-diameter ejecting direction SD of the small-diameter coin SC. Therefore, there is a concern that the ejecting direction is widened.

[0011] Furthermore, since the spring force by the spring is increased as the diameter of the coin C is increased, the rubbing force of the ejecting roller 32 with respect to the coin C is increased. Therefore, the coin is easily spun, rebound thereof upon collision with a guide in a next step is large even if the difference in the ejecting direction is a small angle, and the size of the device may be increased in order to provide a function for converging the rebound.

[0012] Next, matters of concern in the case in which the second prior art is employed will be explained with reference to FIG. 3.

[0013] In this case, except that the fixed roller 36 of the first prior art is comprised of a plate-shaped fixed plate 40, the other structures are the same. The rotation of the rotating disk 12 causes the coin C to be pushed by the pusher 20 and pushes the coin into the part between the fixed plate 40 and the ejecting roller 32, and the coin is finally ejected by the spring force applied to the ejecting roller 32.

[0014] In this case, if the small-diameter coin SC is sandwiched by the fixed plate 40 and the ejecting roller 32, the small-diameter coin SC and the fixed plate 40 are a sliding pair, and the friction resistance thereof is large. Therefore, it is expected that the small-diameter coin SC is moved while sliding on the circumferential surface of the fixed plate 40, and the coin center SCC passes the ejection border line SDLL as a result. Therefore, the influence of the inertial force of the small-diameter coin SC on the ejecting direction is eliminated, and the ejecting direction becomes the small-diameter ejecting direction SD, which is the direction of the vector of the small-diameter resultant force SF3 of the small-diameter pushing force SF1 from the ejecting roller 32 and the small-diameter reactive force SF2 from the fixed plate 40. Also in the case of the large-diameter coin LC, similarly, after the coin center LCC passes the ejection border line LD-DL, the coin is ejected in the large-diameter ejecting direction LD in the direction of the vector of the large-diameter resultant force LF3 of the large-diameter pushing force LF1 and the large-diameter reactive force LF2. The ejecting-direction difference between the small-diameter ejecting direction SD of the small-diameter coin SC and the large-diameter ejecting direction LD of the large-diameter coin LC is small, and there is a tendency that there are no practical problems.

[0015] On the other hand, in a case in which the output power of a driving motor of the rotating disk 12 is reduced in order to respond to recent demands for energy saving, the rotation of the rotating disk 12 may not be able to exceed the friction resistance of the coin C and the fixed plate 40, and the rotation may be stopped. Increasing the size of the motor in order to solve this is against the social needs for energy saving, and it cannot be readily employed.

[0016] There is a concern that the third prior art cannot be applied to a small dispenser since the lever supporting the ejecting roller, which is a movable member, is long.

SUMMARY OF THE INVENTION

[0017] The present invention has an object to solve above described various concerns and below first to third main objects, and other objects will be elucidated in the explanation of embodiments.

[0018] The first object of the present invention is to provide a coin dispenser in which the ejecting direction of coins is a constant direction within a range that does not practically cause problems regardless of the diameters of the coins.

[0019] The second object of the present invention is to provide a power-saving coin dispenser in which the ejecting direction of the coins is a constant direction regardless of the diameters of the coins.

[0020] The third object of the present invention is to provide a power-saving low-price coin dispenser in which the ejecting direction of the coins is a constant direction regardless of the diameters of the coins.

[0021] In order to achieve these objects, the present invention is configured in the below described manner.

[0022] A coin dispenser comprising: a base that supports the surface of a coin; a coin guiding wall that is disposed on the base and forms a circular storage hole partially having an opening; a rotating disk that can be rotated about a rotating axis in the storage hole, forms a plurality of through holes disposed along a circumferential direction at eccentric positions with respect to the rotating axis, and has a pusher disposed between the mutually adjacent through holes in a back side and projecting to the base side; and a fixed roller that is disposed outside of the storage hole on the base and in a first end side of the opening and is practically fixed to the base; and an ejecting roller that is disposed outside of the storage hole on the base with a predetermined interval from the fixed roller and is elastically biased so as to get closer to the fixed roller; the coin dispenser that ejects the coin by an elastic action of the ejecting roller after the coin is moved from the storage hole to a part between the fixed roller and the ejecting roller through the opening by pushing the coin by a pushing front surface of the pusher positioned in a rotating direction side of the rotating disk while guiding the coin on the base by the coin guiding wall by rotation of the rotating disk; wherein a fixed guide is disposed on the base to be adjacent to the fixed roller in downstream of the direction of ejection of the coin, and a state that the coin is sandwiched between the fixed guide and the ejecting roller is generated.

[0023] In the coin dispenser of the present invention, normally, after the coin is guided by the coin guiding wall while the coin is pushed by the pusher and slid on the base by the rotation of the rotating disk, the coin is guided by the fixed roller and subjected to change of direction toward the outer circumferential direction of the rotating disk, and the coin is pushed into the part between the fixed roller and the ejecting roller.

[0024] The condition of fixed roller being a turning pair, coin which is subject to change in direction is guided by

the fixed roller turning pair and is sandwiched by the fixed guide and the ejecting roller. Then, the coin center crosses the ejection border line, which is a straight line connecting a first contact point of the fixed roller and the coin and a second contact point of the ejecting roller and the coin; therefore, ejection of the coin is started by the spring force applied to the ejecting roller. Therefore, since the coin is guided by the turning pair, there are advantages that resistance of movement is small, the coin can pass through the part between the fixed roller and the ejecting roller even when the output power of a driving motor of the rotating disk is reduced, and energy can be saved.

[0025] On the other hand, after the coin center passes the ejection border line and before the coin is ejected, the circumferential surface of the coin is brought into contact with the fixed guide, the coin and the fixed guide become a sliding pair, and the sliding resistance between the coin and the fixed guide becomes large. Therefore, the coin is not ejected until the resultant force of the pushing force of the ejecting roller and the reactive force from the fixed guide exceeds the friction resistance between the fixed guide and the coin, and the influence of the inertial force caused by rotation together by the rotating disk is practically eliminated. As a result, the ejecting direction of the coin is the direction of the vector of the resultant force of the pushing force of the ejecting roller and the reactive force of the fixed guide. Therefore, there are advantages that, even if the diameters of the coins are different, the ejecting direction is not practically changed, and practical processing in a next step is not affected.

[0026] Moreover, since a lever similar to that of prior arts can be used as the lever that supports the ejecting roller, there is an advantage that this can be employed also in a small dispenser.

[0027] In a preferred example of the present invention, the fixed guide is comprised of a first straight part that forms a tangent line with respect to the fixed roller, a second straight part that is formed on a second extension line forming an obtuse angle with respect to an extension line of the first straight part, and a curved part that connects the first straight part and the second straight part to each other.

[0028] In this case, furthermore, even if the ejecting direction is shifted, the coin sandwiched and ejected by the fixed guide and the ejecting roller is guided by the curved part, is then finally guided by the second straight part, and dispensed in the direction along the extension line of the second straight part. Therefore, even when the coins having different diameters are finally ejected in the same direction, there is an advantage that the processing of a next step is not affected.

[0029] In another preferred example of the present invention, the shape of the fixed guide is set so that the coin is in contact with both of the fixed roller and the fixed guide in the state that the coin is sandwiched between the fixed guide and the ejecting roller.

[0030] In this case, moreover, the coin dispenser can

be manufactured at a low price, and the coin is ejected by the ejecting roller in a state in which the coin is in contact with both of the fixed roller and the fixed guide. Therefore, the size of the fixed guide can be reduced, and as a result, there is an advantage that the coin dispenser can be downsized.

BRIEF DESCRIPTION OF THE DRAWINGS

10 **[0031]**

FIG. 1 is an explanatory drawing of dispensing of a small-diameter coin by a first prior art.

FIG. 2 is an explanatory drawing of dispensing of a large-diameter coin by the first prior art.

FIG. 3 is an explanatory drawing of a second prior art.

FIG. 4 is a vertical cross-sectional view of a coin dispenser of a first embodiment of the present invention.

FIG. 5 is a plan view of a state in which a storing bowl of the coin dispenser of the first embodiment of the present invention is removed.

FIG. 6 is a plan view of the coin dispenser of the first embodiment of the present invention (only the storing bowl and pushers of a rotating disk are shown, and others are not shown).

FIG. 7 is an explanatory drawing of a hopper of the coin dispenser of the first embodiment of the present invention.

FIG. 8 is a perspective view of a fixed guide of the coin dispenser of the first embodiment of the present invention.

FIG. 9 is an explanatory drawing of working (guiding by outlet guide upon forward rotation) of the coin dispenser of the first embodiment of the present invention.

FIG. 10 is an explanatory drawing of working (during entrance upon forward rotation) of the coin dispenser of the first embodiment of the present invention.

FIG. 11 is an explanatory drawing of working (upon ejection upon forward rotation) of the coin dispenser of the first embodiment of the present invention.

FIG. 12 is a plan view (during entrance upon forward rotation) of a coin dispenser of a second embodiment of the present invention.

FIG. 13 is a perspective view of a fixed guide of the coin dispenser of the second embodiment of the present invention.

FIG. 14 is an explanatory drawing of working (upon ejection) of the coin dispenser of the second embodiment of the present invention.

FIG. 15 is a plan view (upon start of backward rotation) of a coin dispenser of a third embodiment of the present invention.

FIG. 16 is a perspective view of a fixed guide of the coin dispenser of the third embodiment of the present invention.

FIG. 17 is an explanatory drawing of working (upon

ejection) of the coin dispenser of the third embodiment of the present invention.

FIG. 18 is an explanatory drawing of working (upon dispensing) of the coin dispenser of the third embodiment of the present invention.

DETAILED DESCRIPTION OF THE PREFERRED EMBODIMENTS

[0032] The features and advantages of the invention will be more clearly understood from the following description taken in conjunction with the accompanying drawings.

[First Embodiment]

[0033] A present first embodiment is an example of a coin dispenser that can dispense 1-yen coins 1C, 5-yen coins 5C, 10-yen coins 10C, 50-yen coins 50C, 100-yen coins 100C, and 500-yen coins 500C of Japanese coins. In other words, this is an example of the coin dispenser that can dispense the coins in a range from a small diameter coin SC having a diameter of 20 millimeters of the 1-yen coin 1C to a maximum diameter coin LC having a diameter of 26.5 millimeters of the 500-yen coin one by one.

[0034] However, the present invention is not limited to the above described denominations, but can be also applied to foreign coins, play medals, etc.

[0035] For the convenience of explanation, except for the cases in which coins of particular denominations are explained, explanations will be given while using coins C as a collective term.

[0036] As shown in FIG. 4, a coin dispenser 100 has a function to sort the 1-yen coin 1C to the 500-yen coin 500C, which are in bulk, and then eject the coins one by one. In the present first embodiment, the coin dispenser 100 roughly has: a frame 102, a base 104, a storing bowl 106, a rotating disk 108, a coin guiding wall 110, regulating pins 112, an outlet guide 114, a fixed-side device 118 and an ejecting roller 120 constituting a hopper 116, a coin detector 122, and a coin outlet 124. The frame 102, the base 104, the storing bowl 106, the rotating disk 108, the coin guiding wall 110, the regulating pins 112, the ejecting roller 120 constituting part of the hopper 116, the coin detector 122, and the coin outlet 124 are conventionally publicly known structures. The invention of the present application relates to the structure of the fixed-side device 118.

[0037] First, the frame 102 will be explained mainly with reference to FIG. 4.

[0038] The frame 102 has a function that functional parts such as the base 104, the storing bowl 106, etc. are attached thereto, and the frame 102 in the present first embodiment has a hollow rectangular box shape made of a metal plate.

[0039] An upper-surface opening of the frame 102 is covered with the base 104 having the shape of a rectan-

gular plate.

[0040] An electric motor 123 which is equipped with a decelerator and can be rotated forward and backward is fixed to a back side of the base 104, and an output shaft 125 thereof passes through a circular through hole 128 formed in the base 104 and projects to the upper side of the base 104. If coin jamming occurs, the electric motor 123 is rotated backward for a predetermined period of time and by a predetermined number of rotations, thereby contributing to automatic elimination of the coin jamming.

[0041] The base 104 is horizontally disposed in the present first embodiment, but may be disposed to be tilted.

[0042] Next, the base 104 will be explained mainly with reference to FIG. 4.

[0043] The base 104 has a function that the coins C are pushed and moved on an upper surface thereof by the rotating disk 108. The base 104 is a flat plate made of stainless steel or a resin having abrasion resistance properties, and an upper surface thereof is formed to have predetermined flatness.

[0044] A coin peripheral guiding plate 126 which forms the coin guiding wall 110 and has a predetermined thickness is closely fixed to the upper surface of the base 104.

[0045] Therefore, the base 104 can be replaced by another mechanism that has a similar function.

[0046] Next, the storing bowl 106 will be explained mainly with reference to FIG. 4.

[0047] The storing bowl 106 has a function to store many coins C in bulk. In the present first embodiment, the storing bowl 106 has an approximately vertical tubular shape made of resin, and the inside of the tube is formed into a coin storing unit 121 extending in the vertical direction. The coin storing unit 121 is formed so that a horizontal cross section of an upper portion 106A is rectangular and that a horizontal cross section of a lower portion 106U is formed into a circular bottom hole 130. An intermediate portion 106M between the upper portion 106A and the lower portion 106U is formed into a slope on which the coins C can slide.

[0048] In a lower end part of the storing bowl 106, an attachment part 132 projecting in a lateral direction like a flange is formed, and the storing bowl 106 is fixed to the base 104, specifically, to the coin peripheral guiding plate 126 by using this attachment part 132.

[0049] Therefore, the storing bowl 106 can be changed to another device that has a similar function.

[0050] Next, the rotating disk 108 will be explained mainly with reference to FIGs. 4 and 5.

[0051] The rotating disk 108 has a function to be rotated at a predetermined speed, stir the coins C in the storing bowl 106, push and rotate together the coins C fallen into through holes 136 formed at eccentric positions, and eliminate coin jamming by backward rotation if coin jamming occurs.

[0052] In the present first embodiment, the rotating disk 108 is disposed in the bottom hole 130 of the storing bowl 106, is rotated forward counterclockwise in FIG. 5 at a

predetermined speed upon dispensing of the coins C by a direct-current electric motor 123 fixed to the back side of the base 104, and is rotated backward at a predetermined speed clockwise, which is in the opposite direction, if coin jamming occurs.

[0053] The rotating disk 108 has a stirrer 134 having a polygonal pyramid shape at the center thereof, stirs the coins C by rotating in the bottom hole 130, and facilitates fall of the coins C into the through holes 136.

[0054] The rotating disk 108 has pushers 140 on back sides of respective ribs 138 between the through holes 136.

[0055] The pusher 140 undergoes rotary movement in a circular storage hole 142 of the coin peripheral guiding plate 126, which is closely fixed to the upper surface of the base 104 and has a predetermined thickness. As shown in FIG. 5, a pushing front surface 144 thereof has a curved shape so as to be retreated from a rotating axis RA side of the rotating disk 108 to a rotating-direction rear position side toward a circumferential edge side. Specifically, the pusher 140 is comprised of a first pusher 140A close to the rotating axis RA side and a second pusher 140B close to the circumferential edge side. An arc-shaped first relief groove 146A is formed in the rotating axis RA side of the first pusher 140A, and a second relief groove 146B is formed between the first pusher 140A and the second pusher 140B so that a first regulating pin 112A and a second regulating pin 112B, which will be described later, can pass therethrough. The front surface of the first pusher 140A is a first pushing front surface 144A, and the front surface of the second pusher 140B is a second pushing front surface 144B.

[0056] Therefore, while the coin C which has fallen into the through hole 136 is brought into contact with and supported by the base 104 by the surface thereof and is guided by the coin guiding wall 110 of the storage hole 142, the coin C is pushed by the first pusher 140A by the rotation of the rotating disk 108 and is rotated together with the rotating disk 108 in a moving passage MP. Part of the coin guiding wall 110 is cut out approximately by a length two times the diameter of the small-diameter coin SC to form an outlet opening 148. When the coin C reaches the outlet opening 148, pushing of the coin C is switched to that by the second pusher 140B, and the coin C is moved to the hopper 116 while guiding and pushing the coin by the outlet guide 114 and the ejecting roller 120.

[0057] On the other hand, the coin C that is rotated together with and moved by the rotating disk 108 without being guided by the coin guiding wall 110 is ejected from the base 104 and is forcibly guided in the circumferential direction of the rotating disk 108, in other words, to the upper side of FIG. 5 by the later-described first regulating pins 112 (the first regulating pin 112A and the second regulating pin 112B) positioned in the moving passage MP of the coins C.

[0058] If coin jamming occurs, the rotating disk 108 is rotated backward. As a result of this backward rotation, a rear surface tip 150E of a back side 150 of the second

pusher 140B pushes the circumferential surface of the coin C and moves the coin in the opposite direction of that of forward rotation.

[0059] Next, the coin guiding wall 110 will be explained mainly with reference to FIG. 4 to FIG. 6.

[0060] The coin guiding wall 110 has a function to guide the circumferential surface of the coin C, which is rotated together by the rotating disk 108. In the present first embodiment, the coin guiding wall 110 is an inner wall surface of the approximately circular storage hole 142 formed in the coin peripheral guiding plate 126, which is formed into a rectangle approximately same as the base 104 and has a predetermined thickness, specifically, a thickness slightly larger than the thickness of the thickest coin C among the coins C serving as handling targets; and part thereof is cut to form the outlet opening 148. In other words, the coin guiding wall 110 has a C-shape, and the outlet opening 148 is formed to be about 1.5 times the diameter of the 500-yen coin 500C, which is the maximum diameter coin in the present first embodiment. Specifically, the outlet opening 148 is a slit-like opening formed by an upstream-side end 110E and a downstream-side end 110L of the coin guiding wall 110.

[0061] The coin peripheral guiding plate 126 is closely fixed to the upper surface of the base 104, and the lower surface of the attachment part 132 of the storing bowl 106 is detachably closely fixed to the upper surface of the coin peripheral guiding plate 126. In this state, the rotating axis RA and the axial cores of the bottom hole 130 and the storage hole 142 are disposed to mutually match. In other words, the vertical axes of the rotating disk 108, the bottom hole 130, and the storage hole 142 are mutually the same. The diameter of the rotating disk 108 is formed to be slightly smaller than the diameter of the storage hole 142.

[0062] While the coin C which has fallen into the through hole 136 is pushed by the pusher 140 in the state in which the lower surface thereof is supported by the base 104 in the above described manner, the circumferential surface thereof is guided by the coin guiding wall 110, and the coin is moved in the moving passage MP. In other words, the moving passage MP has an approximately circular ring shape.

[0063] Therefore, the coin peripheral guiding plate 126 is only required to have a function to guide the coins C so that the coins C are guided by the coin guiding wall 110 and moved in the moving passage MP.

[0064] The base 104 and the coin peripheral guiding plate 126 may be integrally formed.

[0065] Next, the regulating pins 112 will be explained mainly with reference to FIG. 6.

[0066] The regulating pins 112 have a function to guide the coin C, which is rotated together by the rotating disk 108, in the circumferential direction of the rotating disk 108, in other words, to the outlet opening 148 side and have a function to be pushed downward by the coin C, which is pushed by the back side 150 of the pusher 140, and allow the coin C to move in the opposite direction in

the moving passage MP when the rotating disk 108 is rotated backward. In the present first embodiment, the regulating pins are comprised of the first regulating pin 112A and the second regulating pins 112B elastically projecting from the upper surface of the base 104. However, if the coin C moves by itself toward the outlet opening 148 side by centrifugal force, the regulating pins 112 are not necessarily required, and the regulating pins 112 can be arbitrarily installed.

[0067] Each of the first regulating pin 112A and the second regulating pin 112B is a cylinder fixed to rise from a second end of a plate spring (not shown) having a first end fixed to the back side of the base 104. The head of the cylinder projects to above the base 104 from a through hole formed in the base 104, but projects by a degree that the head does not abut the back side of the rotating disk 108. A slope 152 (first slope 152A, second slope 152B) tilted so that the component force that pushes the pin into the base 104 is caused to work by the coin C pushed in the opposite direction in the moving passage MP is formed on the head thereof. The shape of the head employs, for example, the invention disclosed in Japanese Utility Model No. 2594435.

[0068] In the present first embodiment, a first extension line EA of the first slope 152A toward the circumferential direction of the rotating disk 108 and a second extension line EB of the second slope 152B toward the center side of the rotating disk 108 are formed to intersect with each other by an obtuse angle Z. When the coin C (in the present first embodiment, 1-yen coin 1C) is rotated together in the opposite direction by the back side 150 of the pusher 140 upon backward rotation of the rotating disk 108 and abuts the second slope 152B, the force toward the axis RA side works with respect to the 1-yen coin 1C. As a result, the 1-yen coin 1C is brought into contact with the first slope 152A and the second slope 152B and then is moved over the first regulating pin 112A and the second regulating pin 112B on which they are formed, thereby carrying out continuous backward rotation of the rotating disk 108. In a case in which a bisector BIS of the obtuse angle Z and a straight line FL which passes through the axis RA orthogonally intersect with each other, the center 1CC of the 1-yen coin 1C is set to be positioned on the bisector BIS in the vicinity of the intersecting part (this is the same also in cases of other denominations). When formed in this manner, even in a case in which the coin C abuts the first slope 152A or the second slope 152B, the component force that works from the abutting first slope 152A or the second slope 152B causes the coin C to be brought into contact with both of the first slope 152A and the second slope 152B approximately uniformly, and large force is prevented from working on part of the circumferential surface of the coin C. Therefore, there is an advantage that dents are not formed on the coin C.

[0069] Therefore, when the coin C is pushed by the pusher 140 upon forward rotation of the rotating disk 108 and collides with the first regulating pin 112A and the

second regulating pin 112B, while the coin C is pushed by the pusher 140, the coin C is guided by the first regulating pin 112A and the second regulating pin 112B and guided toward the outlet opening 148. When the rotating disk 108 is rotated backward, the coin C pushed by the back side 150 of the pusher 140 is placed over the first slope 152A and the second slope 152B at the heads of the first regulating pin 112A and the second regulating pin 112 and is moved over the first regulating pin 112A and the second regulating pin 112B. Therefore, the coin C is kept being pushed by the back side 150 of the pusher 140 and is rotated together in the moving passage MP in the opposite direction of the forward-rotation direction.

[0070] Next, the outlet passage 153 will be explained mainly with reference to FIG. 6.

[0071] The outlet passage 153 is a passage through which the coin C moved from the outlet opening 148 can be moved to the later-described coin outlet 124 and is formed to be continued to the downstream of the outlet opening 148. Therefore, the outlet passage 153 is not required to be formed into a channel shape of which three sides are surrounded or into a rectangular shape of which four sides are surrounded, and the outlet passage 153 is only required to guide at least the lower surface of the coin C. In the present first embodiment, the outlet passage 153 is defined by the upper surface of the base 104, and part of a side wall thereof is defined by a fixed guide 164 of the fixed-side device 118.

[0072] Therefore, the coin C moved from the outlet opening 148 passes through the outlet passage 153 and is released from the later-described coin outlet 124.

[0073] Next, the outlet guide 114 will be explained mainly with reference to FIG. 5.

[0074] The outlet guide 114 has a function to guide the coin C toward the hopper 116 upon forward rotation of the rotating disk 108 and, upon backward rotation of the rotating disk 108, to guide the coin C and returns the coin into the storage hole 142. The outlet guide 114 is comprised of a fan-shaped outlet guide plate 154 positioned in the lateral side in the upstream-side end 110E side of the outlet opening 148. The outlet guide plate 154 is a fan-shaped plate in the present first embodiment and is fixed by rotatably attaching a first end thereof to a fixed shaft 156, which rises from the base 104, and causing a screw 160 to penetrate through a long hole 158 formed in an arc shape about the fixed shaft 156 and to be screwed in the base 104.

[0075] In a case in which the rotating disk 108 is rotated forward in the manner shown in FIG. 9, the 1-yen coin 1C is pushed against the outlet guide plate 154 and the ejecting roller 120 by the second pusher 140B, the coin C is pushed toward the later-described fixed-side device 118 by resultant force F3 of pushing force F1 from the second pusher 140B toward the coin center 1CC and reactive force F2 from the ejecting roller 120 toward the coin center 1CC while the coin is guided by the ejecting roller 120, the coin C is pushed into the part between the fixed-side device 118 and the ejecting roller 120 (FIG.

10), and the coin C is finally sandwiched and ejected by the fixed guide 164 and the ejecting roller 120.

[0076] When the rotating disk 108 is rotated backward, the 1-yen coin 1C is guided by the outlet guide plate 154 and is returned into the storage hole 142 so that the rotating disk 108 can be continuously rotated backward, and coin jamming can be effectively eliminated.

[0077] Next, the hopper 116 will be explained mainly with reference to FIG. 5 and FIG. 7.

[0078] The hopper 116 has a function to eject the coin C, which is pushed in the circumferential direction of the rotating disk 108 by the second pushing front surface 144B of the pusher 140, by spring force of an elastic part. In the present first embodiment, the hopper 116 is comprised of the fixed-side device 118 and the ejecting roller 120.

[0079] First, the fixed-side device 118 will be explained.

[0080] The fixed-side device 118 has a function to receive the coin C, which has been pushed by the pusher 140 and pushed out to the outlet opening 148, and guide the coin in the circumferential direction of the rotating disk 108, in other words, has a function to define one side of the outlet passage 153 and a function to sandwich and eject the coin C together by the ejecting roller 120. In the present first embodiment, the fixed-side device 118 is comprised of a first fixed roller 162 serving as a fixed roller 161 and the first fixed guide 164 serving as a fixed guide 163.

[0081] The first fixed roller 162 is not completely fixed and is preferred to be set so as to be slightly moved and buffer excessive force when the excessive force is applied in the later described manner. This is for improving the durability of the dispenser.

[0082] In the present first embodiment, the first fixed roller 162 is projecting upward from a first lever 168 rotatably supported by a second supporting shaft 166 projecting downward to the back side of the base 104, and is a ball bearing roller 172, which is penetrating through a through hole (not shown) formed in the base 104 and is rotatably supported by a tip of a third supporting shaft 170 positioned in the upper side of the base 104. Specifically, an inner race of the ball bearing roller 172 is fixed to the third supporting shaft 170, and an outer race thereof is utilized as a roller. The first lever 168 is biased clockwise in FIG. 5 and FIG. 7 by the spring force of an elastic part, which is a first spring 174 in the present first embodiment. At the position of FIG. 5, in other words, at the position adjacent to the downstream-side end 110L of the storage hole 142, turning of the first lever 168 is stopped and maintained in a still state by a first stopper 176.

[0083] At this still position, the inner circumferential surface of the circumferential surface of the ball bearing roller 172 is disposed on a virtual circle of the storage hole 142 so as to form part of the inner surface of the storage hole 142.

[0084] The spring force of the first spring 174 is set so

that, when the coin C is collided in a normal case, the first spring 174 is not moved, but is slightly moved for relief when the force larger than the normal case works. This is for a reason that even slight movement for relief can buffer the overload caused by the coin C and contributes to improvement of the durability of the dispenser.

[0085] Next, the first fixed guide 164 will be explained mainly with reference to FIG. 8.

[0086] The first fixed guide 164 has a function to guide the coin C, which has been guided by the first fixed roller 162, in a predetermined direction and a function to sandwich the coin C between the guide and the ejecting roller 120 and finally eject the coin. In the present first embodiment, a first straight part 178 is formed in order to define part of the outlet passage 153.

[0087] The first straight part 178 is formed so that an extension line EL thereof forms an acute angle A of about 30 degrees with respect to a perpendicular line VL passing through the rotating axis RA shown in FIG. 5, and the extension line EL is close to the circumferential surface of the first fixed roller 162. Furthermore, the circumferential surface of the first fixed roller 162 is disposed so as to be close to a tangent line CL with respect to the coin guiding wall 110 in the downstream-side end 110L of the coin guiding wall 110 and form an acute angle B close to 90 degrees with respect to the extension line EL.

[0088] A tip 164T of the first straight part 179 in the rotating disk 108 side is disposed so as to be positioned on or close to a first straight line AL connecting a second rotating axis RB of the first fixed roller 162 and a third rotating axis RC of the ejecting roller 120 positioned at a still position SP.

[0089] Therefore, the tip 164T of the first fixed guide 164 in the rotating disk 108 side is formed into the shape of a blade tip of a knife by the first straight part 178 and an arc-shaped portion 165 for avoiding the first fixed roller 162.

[0090] In the present first embodiment, the first fixed guide 164 is formed to be separated from the base 104 and the coin peripheral guiding plate 126, but may be integrally formed with one of or both of them.

[0091] Next, the ejecting roller 120 will be explained mainly with reference to FIG. 7.

[0092] The ejecting roller 120 has a function to eject the coin C, which has been pushed into the outlet passage 153 and is in contact with the first fixed guide 164. In the present first embodiment, the ejecting roller 120 is a roller which is fixed upward from an end of a second lever 182 of which part is rotatably supported by a fourth supporting shaft 179 projecting downward from the back side of the base 104, and the roller is rotatably attached to an upper end of a fifth supporting shaft 181, which penetrates through an arc-shaped long hole 180 formed in the base 104 like an arc about the fourth supporting shaft 179 and is projecting to the upper side of the base 104. In the present first embodiment, the ejecting roller 120 is a ball bearing roller 183. As well as the ball bearing roller 172, the outer race of the ball bearing roller 183 is

also utilized as a roller.

[0093] Therefore, the ejecting roller 120 can be changed to another device having a similar function.

[0094] The second lever 182 is elastically biased so as to get close to the fixed-side device 118 side by a second spring 190 of which ends are stopped by a first stopper part 186 formed at part thereof and by a second stopper part 188 projecting downward from the base 104. The second lever 182 is stopped by a second stopper 192, which is projecting downward from the back side of the base 104, so as to be still at a position at which a straight-line distance L between the tip 164T of the first fixed guide 164 and the ejecting roller 120 is slightly smaller than an expected minimum diameter of dispensed coins. Specifically, the shortest distance L between the tip 164T of the first fixed guide 164 and the ejecting roller 120 forms an entrance gap 194, which is set to be slightly smaller than the diameter of the 1-yen coin 1C, between the tip 164T and the ejecting roller 120.

[0095] Therefore, as shown in FIG. 11, from a point immediately after the center 1CC of the 1-yen coin 1C pushed by the pusher 140 crosses an ejecting border line DDL connecting a first contact point PA of the tip 164T of the first fixed guide 164 and the 1-yen coin 1C and a second contact point PB of the ejecting roller 120 and the circumferential surface of the 1-yen coin 1C, the ejecting roller 120 ejects the coin by the spring force of the second spring 190. This ejecting direction is the direction of the vector of resultant force F13 of pushing force F11 by the ejecting roller 120 and reactive force F12 from the first fixed guide 164.

[0096] Specifically, the forward rotation of the rotating disk 108 causes the 1-yen coin 1C to be pushed by the second pusher 140B and be guided by the outlet guide plate 154, and the 1-yen coin 1C is guided by the ejecting roller 120 and moved toward the entrance gap 194 (FIG. 9). When the rotating disk 108 is further rotated, the coin C is pushed into the entrance gap 194 by the pushing force of the second pusher 140B (FIG. 7), and the ejecting roller 120 is moved in the direction to get away from the first fixed roller 162 against the spring force of the second spring 190. In this process, the contact of the 1-yen coin 1C is switched from that by the first fixed roller 162 to that by the tip 164T of the first fixed guide 164. Specifically, the entrance gap 194 is widened, the first contact point PA is formed at the contact point with the tip 164T of the first fixed guide 164, and the coin center 1CC of the 1-yen coin 1C passes through the ejection border line DDL connecting the first contact point PA and the second contact point PB; immediately after this, the 1-yen coin 1C is ejected by the spring force of the second spring 190 (FIG. 11). The ejected 1-yen coin 1C is dispensed from coin outlet 124 through the outlet passage 153. In the process of this dispensing, the coin C is detected by the coin detector 122.

[0097] Next, the coin detector 122 will be explained.

[0098] The coin detector 122 has a function to detect the coin C, which is ejected by the hopper 116, and an

electromagnetic metal sensor 196 is used in the present first embodiment. Therefore, the coin detector 122 can be changed to another system that has a similar function such as a photoelectric sensor, a mechanical sensor, or the like.

[0099] In the present first embodiment, the coin detector 122 is disposed in the middle of the outlet passage 153, but may be disposed in the downstream of the coin outlet 124.

[0100] In the end, the coin outlet 124 will be explained with reference to FIG. 5.

[0101] The coin outlet 124 has a function to feed coin C from the base 104, is not particularly required to be formed into a slit-shaped passage or the like, and the coin outlet 124 is formed at a downstream end of the outlet passage 153 in the present first embodiment. In other words, an end of the base 104 opposed to the outlet passage 153 is the coin outlet 124.

[0102] Next, working of the coin dispenser 100 will be explained also with reference to FIG. 9 to FIG. 11.

[0103] When the coins of diameters within a predetermined range are to be dispensed by one dispenser without part replacement and position adjustment, the minimum diameter coin SC is the most problematic. Therefore, the 1-yen coin 1C will be taken as an example for explanation.

[0104] Working is different in a case in which the 1-yen coin 1C is moved along the coin guiding wall 110 of the storage hole 142 and a case in which the coin C is guided and dispensed by the regulating pins 112. Therefore, the explanation will be given separately in the cases.

[0105] First, the case in which the 1-yen coin 1C is moved along the coin guiding wall 110 will be explained.

[0106] The coin C in the storing bowl 106 is dropped into the through hole 136 by the rotation of the rotating disk 108; the surface of the front side or back side thereof is brought into contact with and supported by the base 104; and, while the coin is pushed by the first pusher 140A and guided by the coin guiding wall 110 which is the circumferential wall of the storage hole 142, the coin is moved to the outlet opening 148 side (FIG. 10).

[0107] The coin C, which has reached the outlet opening 148, is guided by the outlet guide plate 154 subsequent to by the upstream-side end 110E (FIG. 6), is then brought into contact with the ejecting roller 120 positioned at a standby position SP and guided to the first fixed roller 162 side (FIG. 9), and is pushed to the entrance gap 194 (FIG. 10).

[0108] Further rotation of the rotating disk 108 causes the 1-yen coin 1C to be further pushed into the entrance gap 194 by the second pushing front surface 144B. As a result, the coin is moved in the circumferential direction of the rotating disk 108 along the arc-shaped circumferential surface of the first fixed roller 162. Therefore, the ejecting roller 120 is turned clockwise in FIG. 5, and the entrance gap 194 is further expanded.

[0109] Then, the 1-yen coin 1C is further moved in the circumferential direction of the rotating disk 108, the con-

tact between the circumferential surface thereof and the fixed-side device 118 is switched to that from the first fixed roller 162 to the tip 164T of the first fixed guide 164, and, immediately after the center 1CC of the 1-yen coin 1C passes the ejection border line DDL connecting the first contact point PA of the tip 164T of the first fixed guide 164 and the 1-yen coin 1C and the second contact point PB of the ejecting roller 120 and the circumferential surface of the 1-yen coin 1C, the coin receives the ejecting force from the ejecting roller 120. Then, the ejecting roller 120 pushes the circumferential surface of the 1-yen coin 1C by the spring force of the second spring 190, and, as described above, the 1-yen coin 1C is ejected in the direction of the vector of the resultant force F13 of the pushing force F11 and the reactive force F12 (FIG. 11).

[0110] The ejected 1-yen coin 1C is dispensed from the coin outlet 124 through the outlet passage 153.

[0111] Next, the case in which the 1-yen coin 1C is guided by the first regulating pin 112A and the second regulating pin 112B and pushed into the entrance gap 194 without being guided by the coin guiding wall 110 will be explained.

[0112] In this case, the 1-yen coin 1C is moved to the entrance gap 194 without contacting the outlet guide plate 154, is then guided by the first fixed roller 162 as described above, and is then ejected by the ejecting roller 120 in a state in which the coin is in contact with the tip 164T of the first fixed guide 164.

[Second Embodiment]

[0113] Next, a second embodiment will be explained with reference to FIG. 12 to FIG. 14.

[0114] The second embodiment is an example in which the fixed-side device 118 is comprised of a second fixed roller 200 serving as the fixed roller 161 and a second fixed guide 202 serving as the fixed guide 163 and is the same as the first embodiment except for the second fixed roller 200 and the second fixed guide 202. Therefore, only different configurations and working will be explained.

[0115] The second fixed roller 200 employs a roller having a diameter slightly larger than that of the first fixed roller 162. Specifically, the second fixed roller 200 utilizes the outer race of a standardized ball earring roller as a roller, thereby enabling manufacturing at low cost.

[0116] Since the diameter of the second fixed roller 200 is larger, a second extension line EL2 which is the extension line of a first straight part 204 corresponding to the first straight part 178 of the second fixed guide 202 forms an angle A, which is the same acute angle as that of the first embodiment, with respect to the perpendicular line VL. However, a tip 204T thereof is positioned to be more distant from the first straight line AL compared with the first embodiment.

[0117] Because of the difference of the layout of the tip 204T, the second embodiment is configured so that the 1-yen coin 1C is ejected by the ejecting roller 120 in

a state in which the 1-yen coin 1C is in contact with both of the second fixed roller 200 and the tip 204T of the second fixed guide 204 (FIG. 11).

[0118] Next, working of the second embodiment will be explained.

[0119] As well as the first embodiment, since the 1-yen coin 1C is pushed into the entrance gap 194 by the second pushing front surface 144B, the 1-yen coin 1C is moved in the circumferential direction of the rotating disk 108 along the arc-shaped circumferential surface of the second fixed roller 200. Therefore, the ejecting roller 120 is turned clockwise in FIG. 12, and the entrance gap 194 is further expanded. Then, the 1-yen coin 1C is further moved in the circumferential direction of the rotating disk 108, and, immediately after the center 1CC of the 1-yen coin 1C passes the ejection border line DDL connecting the first contact point PA of the circumferential surface thereof and the second fixed roller 200 and the second contact point PB of the ejecting roller 120 and the circumferential surface of the 1-yen coin 1C, the 1-yen coin 1C receives ejecting force from the ejecting roller 120 (FIG. 14).

[0120] Then, in a state in which the circumferential surface of the 1-yen coin 1C is in contact with the tip 204T of the first straight part 204 and the second fixed roller 200, the ejecting roller 120 pushes the circumferential surface of the 1-yen coin 1C by the spring force of the second spring 190 to eject it (FIG. 14).

[0121] More specifically, immediately after the center 1CC of the 1-yen coin 1C passes the ejection border line DDL connecting a middle point PM of the contact point of the second fixed roller 200 and the circumferential surface of the 1-yen coin 1C and the contact point of the tip 204T and the circumferential surface of the 1-yen coin 1C and the second contact point PB of the ejecting roller 120 and the circumferential surface of the 1-yen coin 1C, the 1-yen coin 1C receives ejecting force from the ejecting roller 120. Then, the ejecting roller 120 pushes the circumferential surface of the 1-yen coin 1C by the spring force of the second spring 190 to eject the coin. The ejecting direction thereof is the direction of the vector of the resultant force F23 of the pushing force F21 from the ejecting roller 120 and the reactive force F22 from the second fixed roller 200 and the tip 204T.

[0122] Then, the case in which the 1-yen coin 1C is guided by the regulating pins 112A and 112B and pushed into the entrance gap 194 without being guided by the coin guiding wall 110.

[0123] In this case, without being brought into contact with the outlet guide plate 154, the 1-yen coin 1C is moved to the entrance gap 194 and is then ejected by the ejecting roller 120 in a state in which the coin is in contact with the tip 204T of the first straight part 204 and the second fixed roller 200 as described above.

[Third Embodiment]

[0124] Next, a third embodiment of the present inven-

tion will be explained with reference to FIG. 15 to FIG. 18.

[0125] The third embodiment is a modification of the second embodiment, wherein a third fixed guide 206 serving as the fixed guide 163 adds a second straight part 208 and a curved part 210 to the second fixed guide 202.

[0126] In other words, the third fixed guide 206 has a function to guide the coin C, which has been guided by the second fixed roller 200, to a predetermined direction and a function to sandwich the coin C between the third fixed guide and the ejecting roller 120 and finally eject the coin. In the present third embodiment, sequentially from the second fixed roller 200 side, the first straight part 204, the curved part 210, and the second straight part 208 are formed.

[0127] The first straight part 204 has the same configuration as that of the second embodiment.

[0128] The second straight part 208 is formed in parallel to the perpendicular line VL, which passes through the rotating axis RA in FIG. 15. Therefore, an extension line EL2 of the second straight part 208 is configured to form an obtuse angle C equal to or more than 90 degrees and less than 180 degrees with the extension line EL of the first straight part 204. In other words, the coin C, which is moved along the first straight part 204, is guided to the curved part 210 and is then dispensed from the coin outlet 124 while being guided by the second straight part 208.

[0129] The curved part 210 is formed into an arc shape, which smoothly connects the first straight part 204 and the second straight part 208 to each other.

[0130] The second straight part 208, which determines the final dispensing direction of the coin C, is arbitrarily determined by the dispensing direction of the coin C and is not required to be parallel to the perpendicular line VL, but may be a curved line.

[0131] In the third embodiment, an outlet roller 212 is used in the outlet guide 114 instead of the outlet guide plate 154 of the first and second embodiments.

[0132] The outlet roller 212 is rotatably supported by a sixth supporting shaft 216 provided to rise upward from the base 104, is disposed in the middle between the upstream-side end 110E of the coin guiding wall 110 and the ejecting roller 120 and in the lateral side of the outlet passage 153, and is disposed to be away by a predetermined distance from a second straight line L2, which forms a tangent line with the ejecting roller 120 positioned at the standby position SP and connects the upstream-side end 110E. Specifically, the second straight line L2 and a cylindrical surface 214 of the outlet roller 212 are disposed to be away from each other by the minimum distance that is half the diameter of the outlet roller 212. The position of the outlet roller 212 is disposed at the position by which the minimum diameter coin serving as a target, which is the 1-yen coin 1C in the present third embodiment, can be pushed by the rotating disk 108 rotating backward, in other words, the back-side tip 150E of the pusher 140 and returned into the storage hole 142. Thus, the rotating disk 108 can be continuously rotated

backward, and coin jamming can be effectively eliminated.

[0133] Next, working of the third embodiment will be explained also with reference to FIG. 17 and FIG. 18.

[0134] The working/effects that part of the coin C is brought into contact with the second fixed roller 200 and the second fixed guide 202 and ejected by the ejecting roller 120 are the same as those of the second embodiment. Therefore, the working/effects of the curved part 210 and the second straight part 208 after ejection by the ejecting roller 120 will be explained.

[0135] In the state in which the circumferential surface of the 1-yen coin 1C is in contact with the tip 204T of the first straight part 204 and the fixed roller 200, the ejecting roller 120 pushes the circumferential surface of the 1-yen coin 1C by the spring force of the second spring 190 and ejects the coin toward the direction of the vector of the resultant force F23, in other words, toward the curved part 210 (FIG. 17).

[0136] The ejected 1-yen coin 1C is guided to the curved part 210, is then guided by the second straight part 208, and is dispensed from the coin outlet 124 in the direction parallel to the perpendicular line VL (FIG. 18). More specifically, the 1-yen coin 1C is finally guided by the second straight part 208 and is dispensed in the direction along the perpendicular line VL.

[0137] Since all the coins C are guided to the curved part 210 and then guided by the second straight part 208, the coins are dispensed in the same direction along the perpendicular line VL.

Claims

1. A coin dispenser comprising:

- a base that supports the surface of a coin;
 - a coin guiding wall that is disposed on the base and forms a circular storage hole partially having an opening;
 - a rotating disk that can be rotated about a rotating axis in the storage hole, forms a plurality of through holes disposed along a circumferential direction at eccentric positions with respect to the rotating axis, and has a pusher disposed between the mutually adjacent through holes in a back side and projecting to the base side; and
 - a fixed roller that is disposed outside of the storage hole on the base and in a first end side of the opening and is practically fixed to the base; and
 - an ejecting roller that is disposed outside of the storage hole on the base with a predetermined interval from the fixed roller and is elastically biased so as to get closer to the fixed roller;
- the coin dispenser that ejects the coin by an elastic action of the ejecting roller after the coin is moved from the storage hole to a part between

the fixed roller and the ejecting roller through the opening by pushing the coin by a pushing front surface of the pusher positioned in a rotating direction side of the rotating disk while guiding the coin on the base by the coin guiding wall by rotation of the rotating disk; wherein
 a fixed guide is disposed on the base to be adjacent to the fixed roller in downstream of the direction of ejection of the coin, and
 a state that the coin is sandwiched between the fixed guide and the ejecting roller is generated.

- 2. The coin dispenser according to claim 1, wherein the fixed guide is comprised of a first straight part that forms a tangent line with respect to the fixed roller, a second straight part that is formed on a second extension line forming an obtuse angle with respect to an extension line of the first straight part, and a curved part that connects the first straight part and the second straight part to each other.
- 3. The coin dispenser according to claim 1, wherein the shape of the fixed guide is set so that the coin is in contact with both of the fixed roller and the fixed guide in the state that the coin is sandwiched between the fixed guide and the ejecting roller.

pushing front surface of the pusher positioned in a rotating direction side of the rotating disk while guiding the coin on the base by the coin guiding wall by rotation of the rotating disk; wherein
 a fixed guide is disposed on the base to be adjacent to the fixed roller in downstream of the direction of ejection of the coin, wherein the fixed side guide is configured to enable a state that the coin is sandwiched between the fixed guide and the ejecting roller is generated, wherein
 the shape of the fixed guide is set so that the coin is in contact with both of the fixed roller and the fixed guide in the state that the coin is sandwiched between the fixed guide and the ejecting roller.

- 2. The coin dispenser according to claim 1, wherein the fixed guide is comprised of a first straight part that forms a tangent line with respect to the fixed roller, a second straight part that is formed on a second extension line forming an obtuse angle with respect to an extension line of the first straight part, and a curved part that connects the first straight part and the second straight part to each other.

Amended claims in accordance with Rule 137(2) EPC.

- 1. A coin dispenser comprising:
 - a base that supports the surface of a coin;
 - a coin guiding wall that is disposed on the base and forms a circular storage hole partially having an opening;
 - a rotating disk that can be rotated about a rotating axis in the storage hole, forms a plurality of through holes disposed along a circumferential direction at eccentric positions with respect to the rotating axis, and has a pusher disposed between the mutually adjacent through holes in a back side and projecting to the base side; and
 - a fixed roller that is disposed outside of the storage hole on the base and in a first end side of the opening and is practically fixed to the base; and
 - an ejecting roller that is disposed outside of the storage hole on the base with a predetermined interval from the fixed roller and is elastically biased so as to get closer to the fixed roller;
 the coin dispenser is configured to eject the coin by an elastic action of the ejecting roller after the coin is moved from the storage hole to a part between the fixed roller and the ejecting roller through the opening by pushing the coin by a

FIG. 1
PRIOR ART

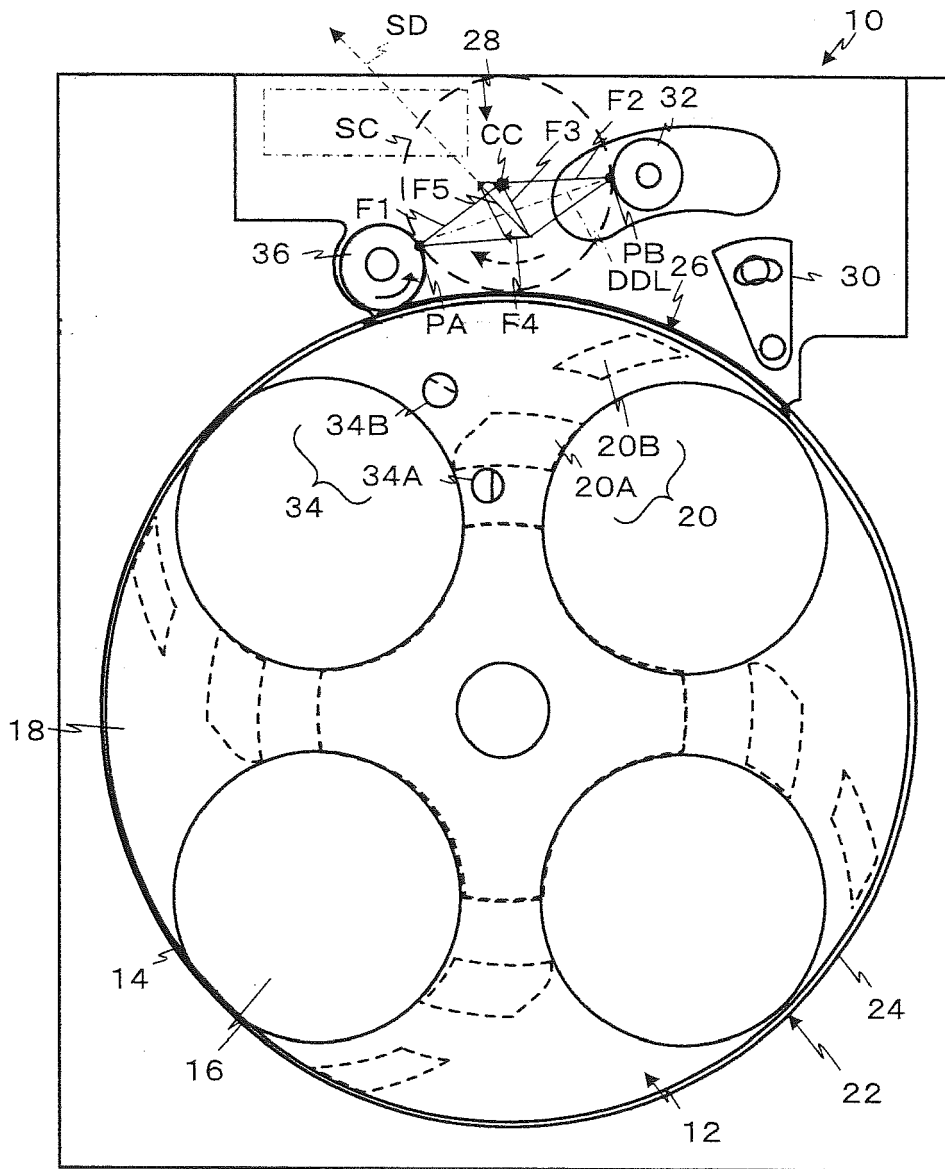

FIG.2
PRIOR ART

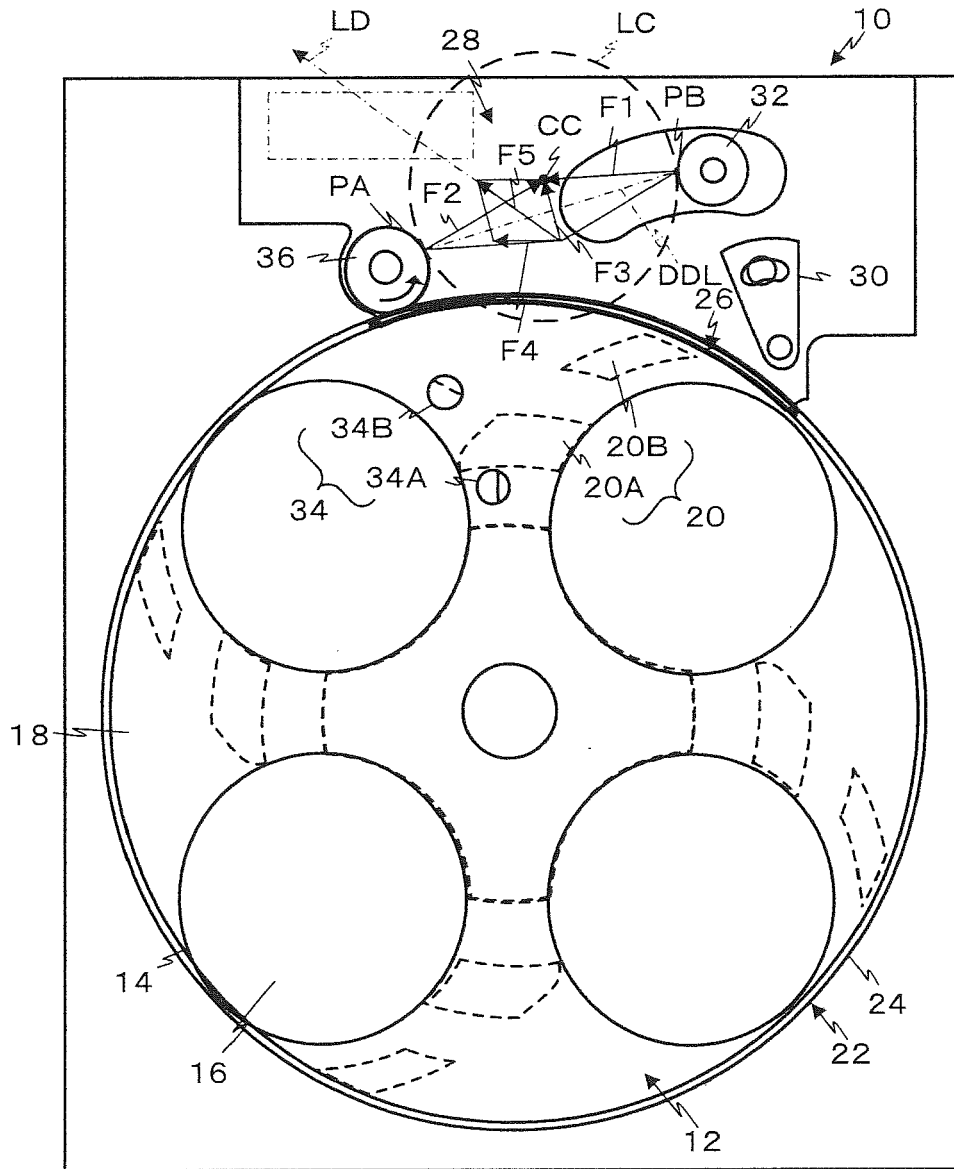

FIG.3
PRIOR ART

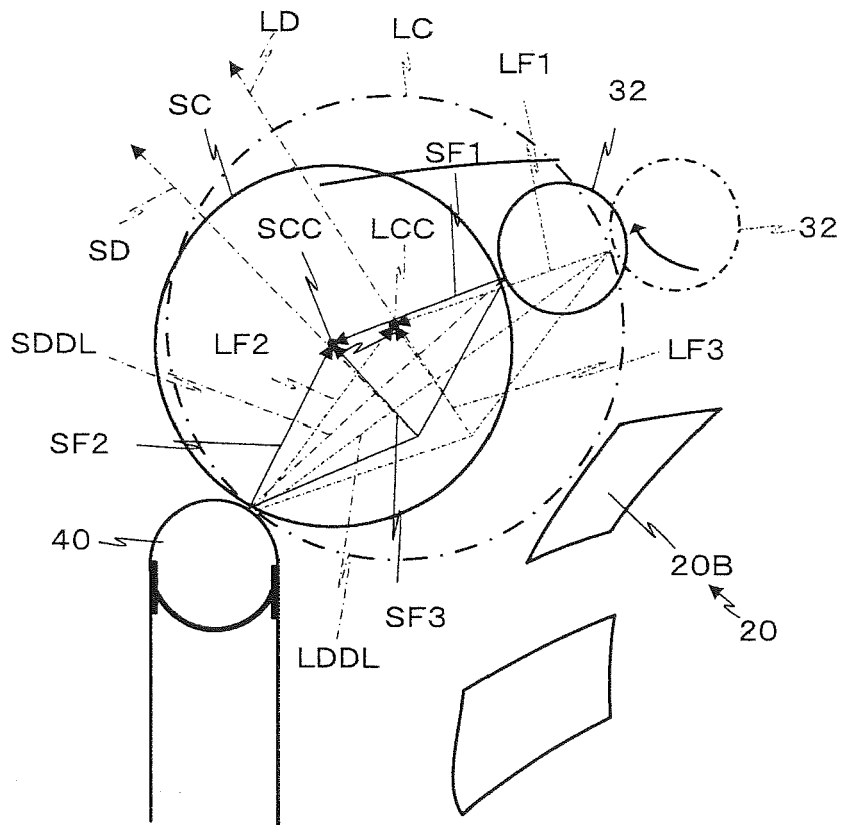

FIG.4

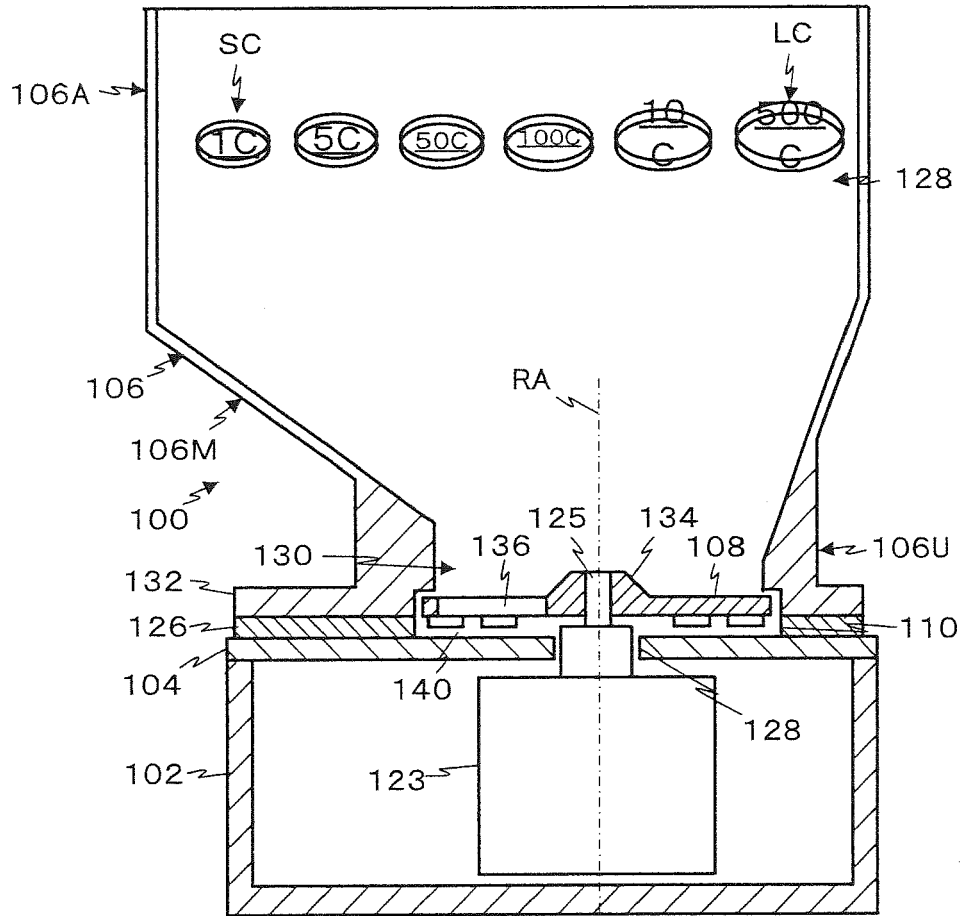

FIG.5

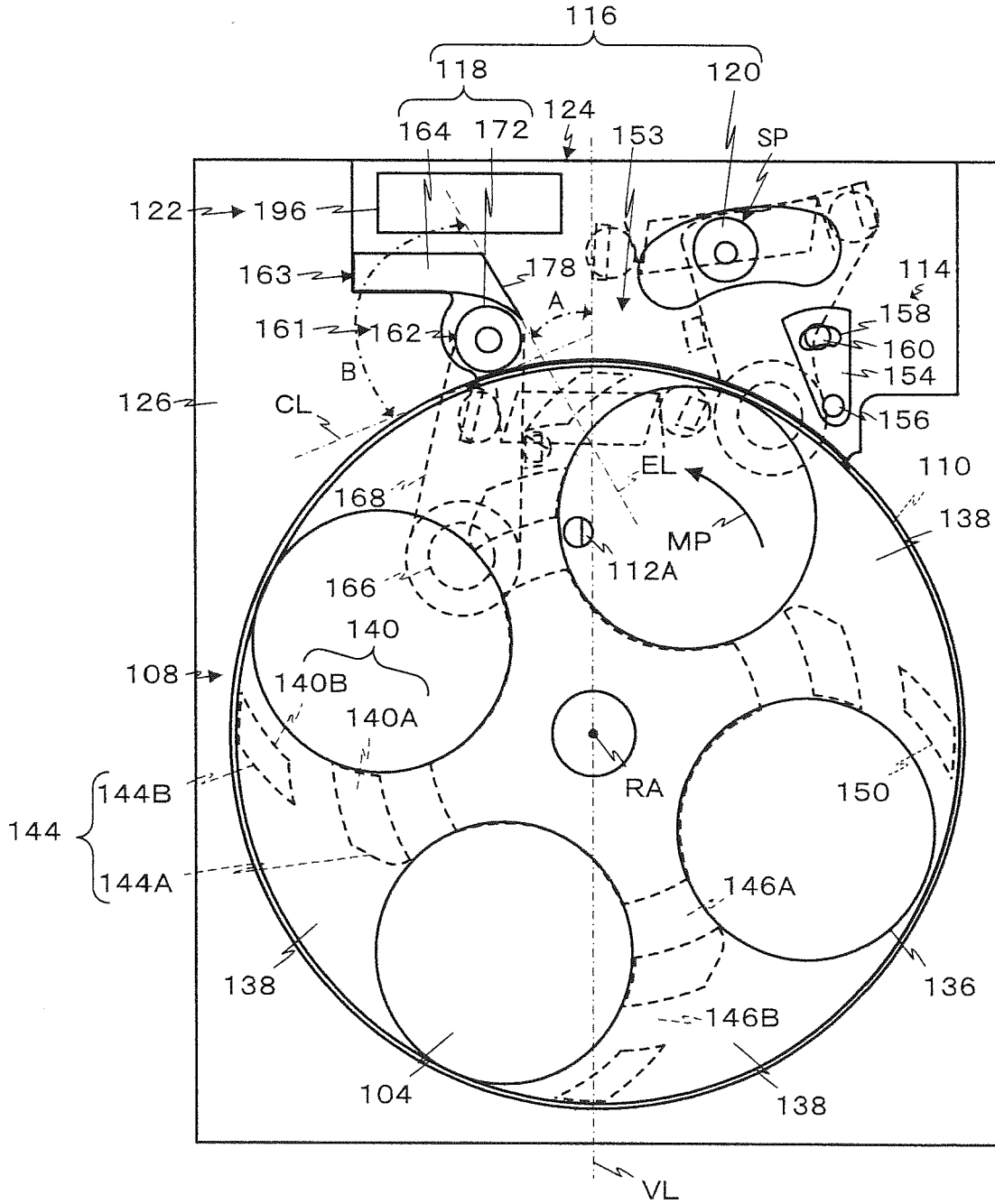

FIG.6

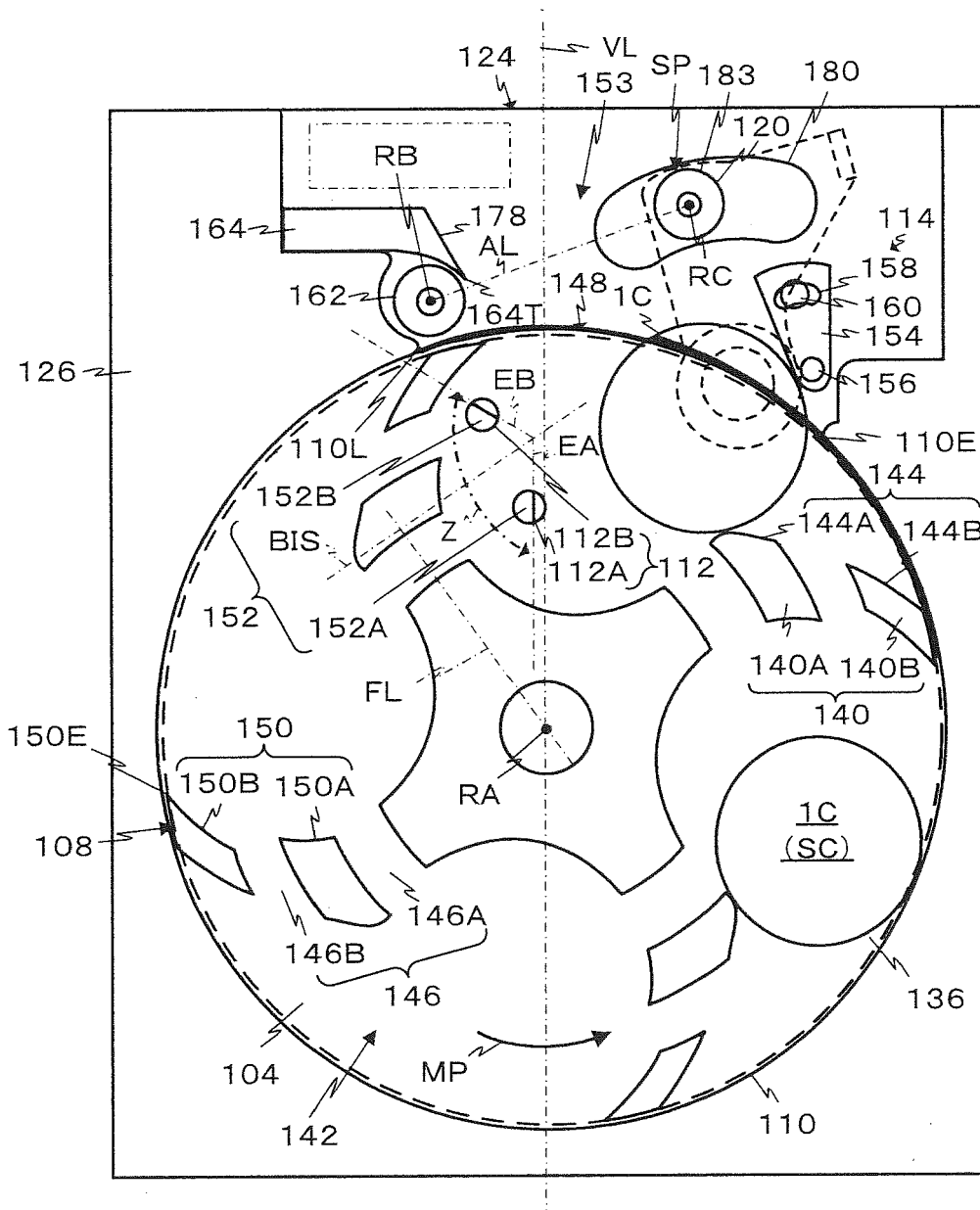

FIG.7

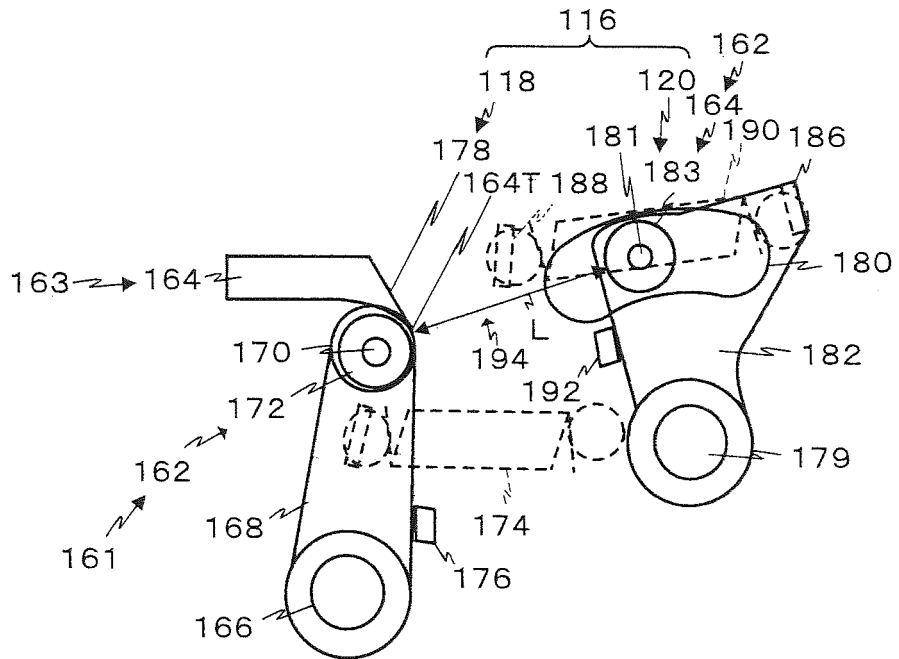

FIG.8

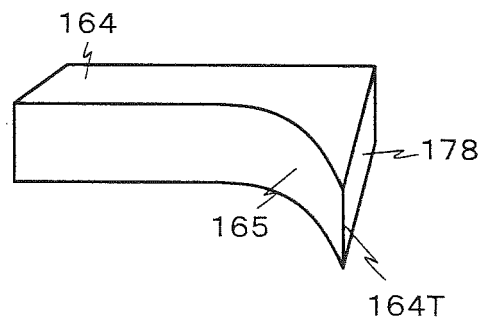

FIG. 9

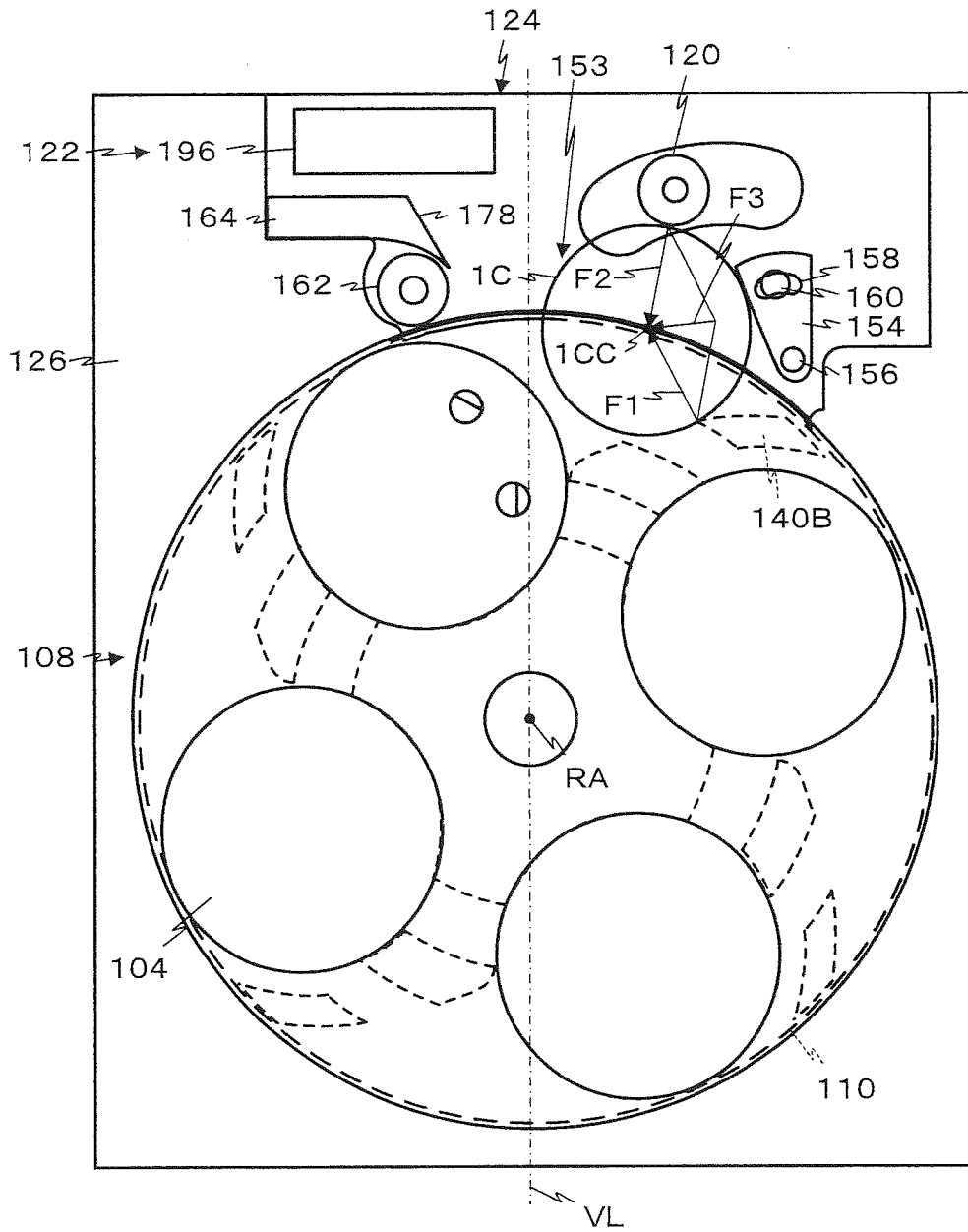

FIG. 10

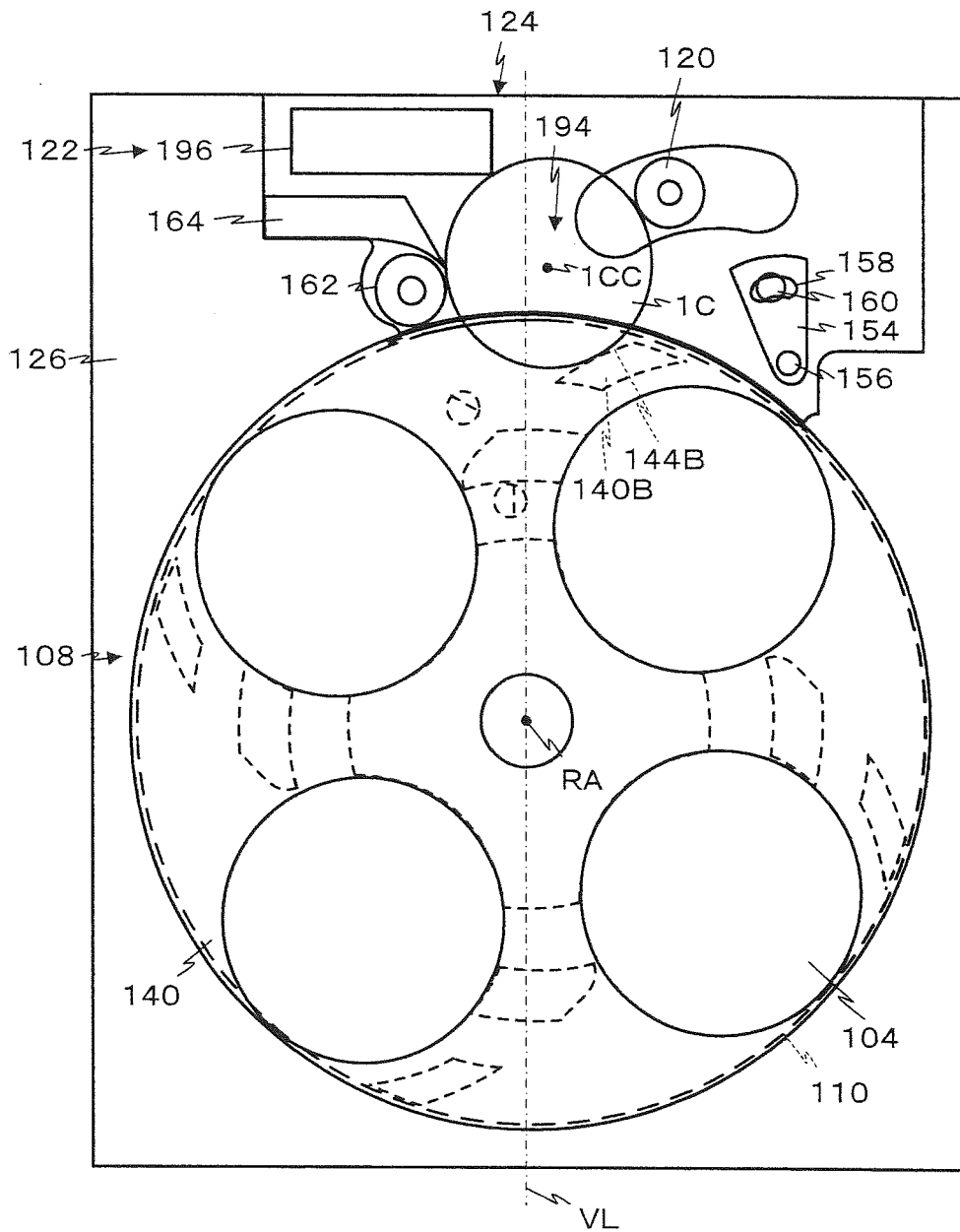

FIG. 11

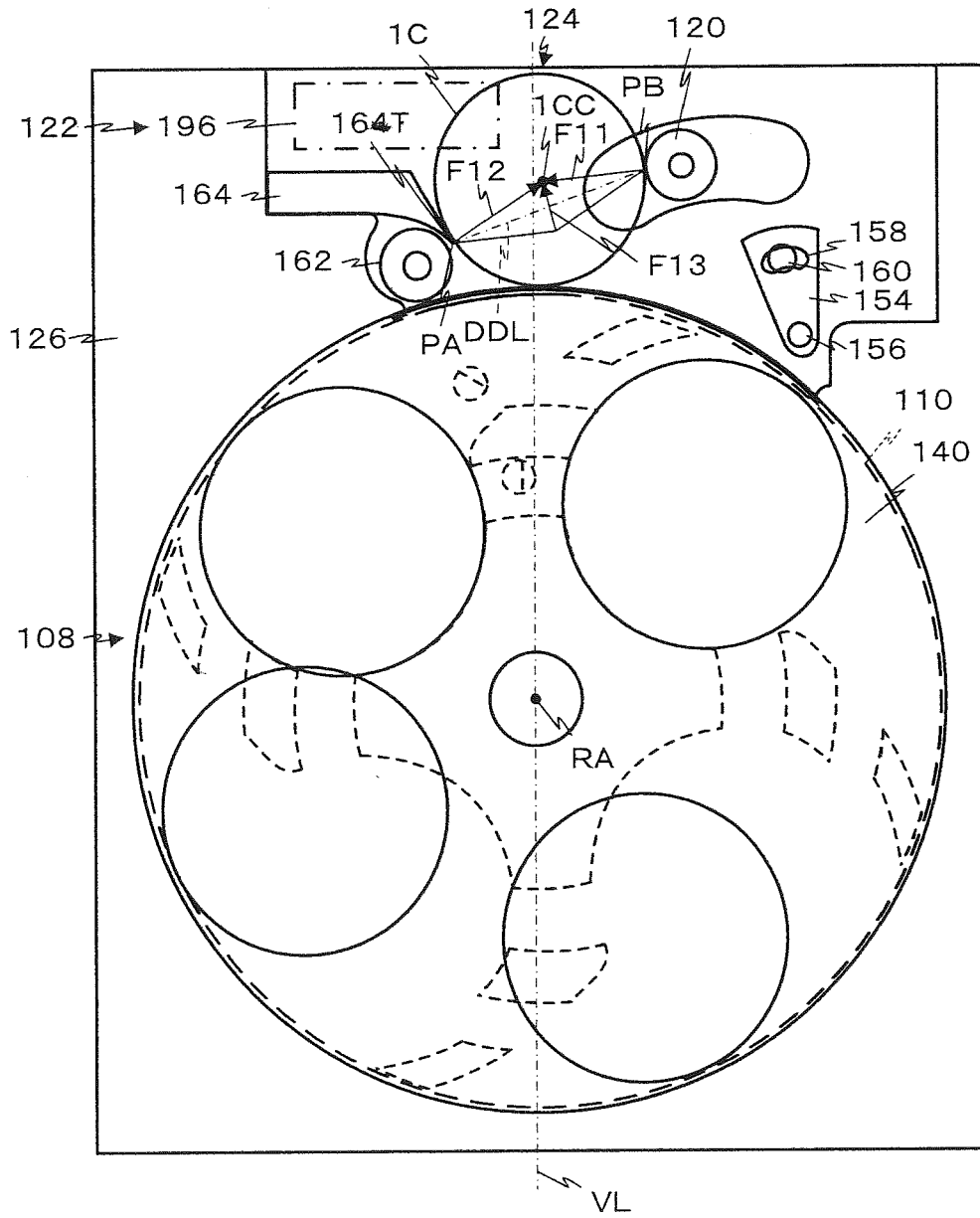

FIG. 12

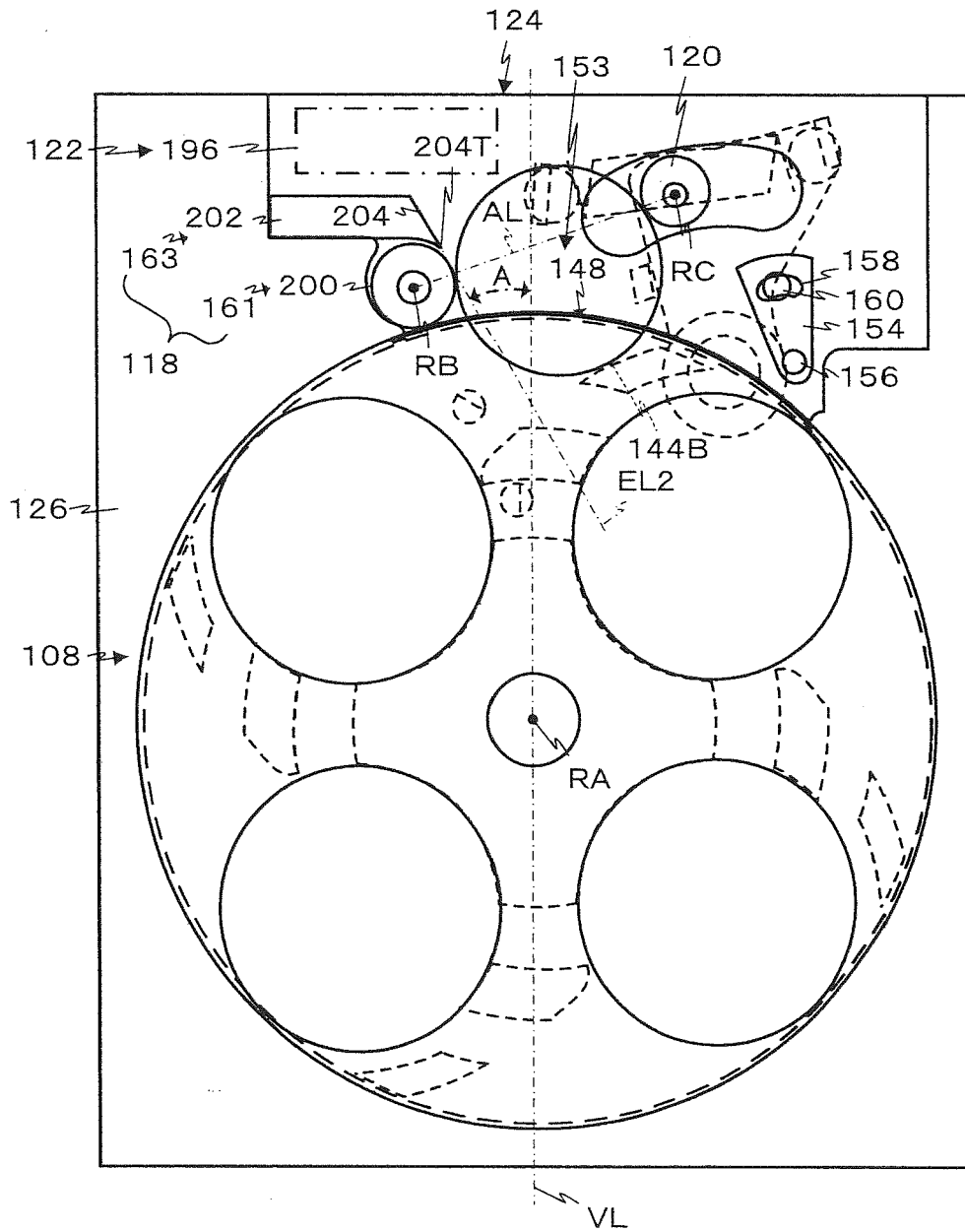

FIG. 13

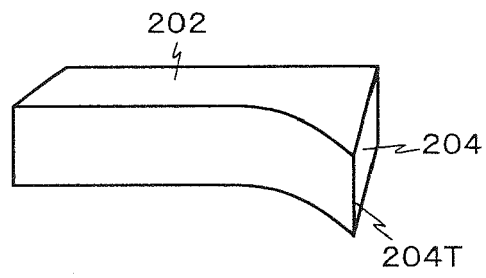

FIG. 14

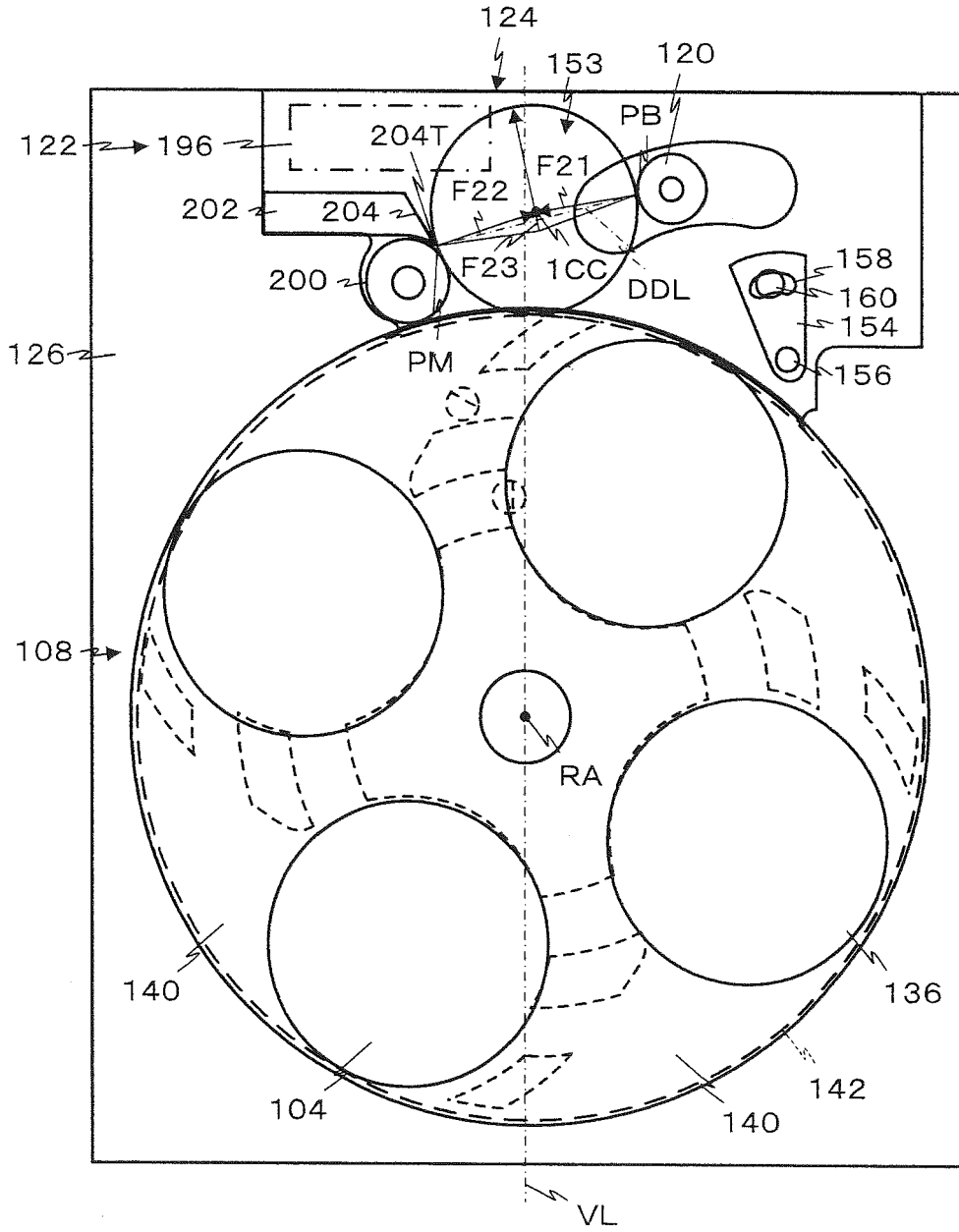

FIG. 15

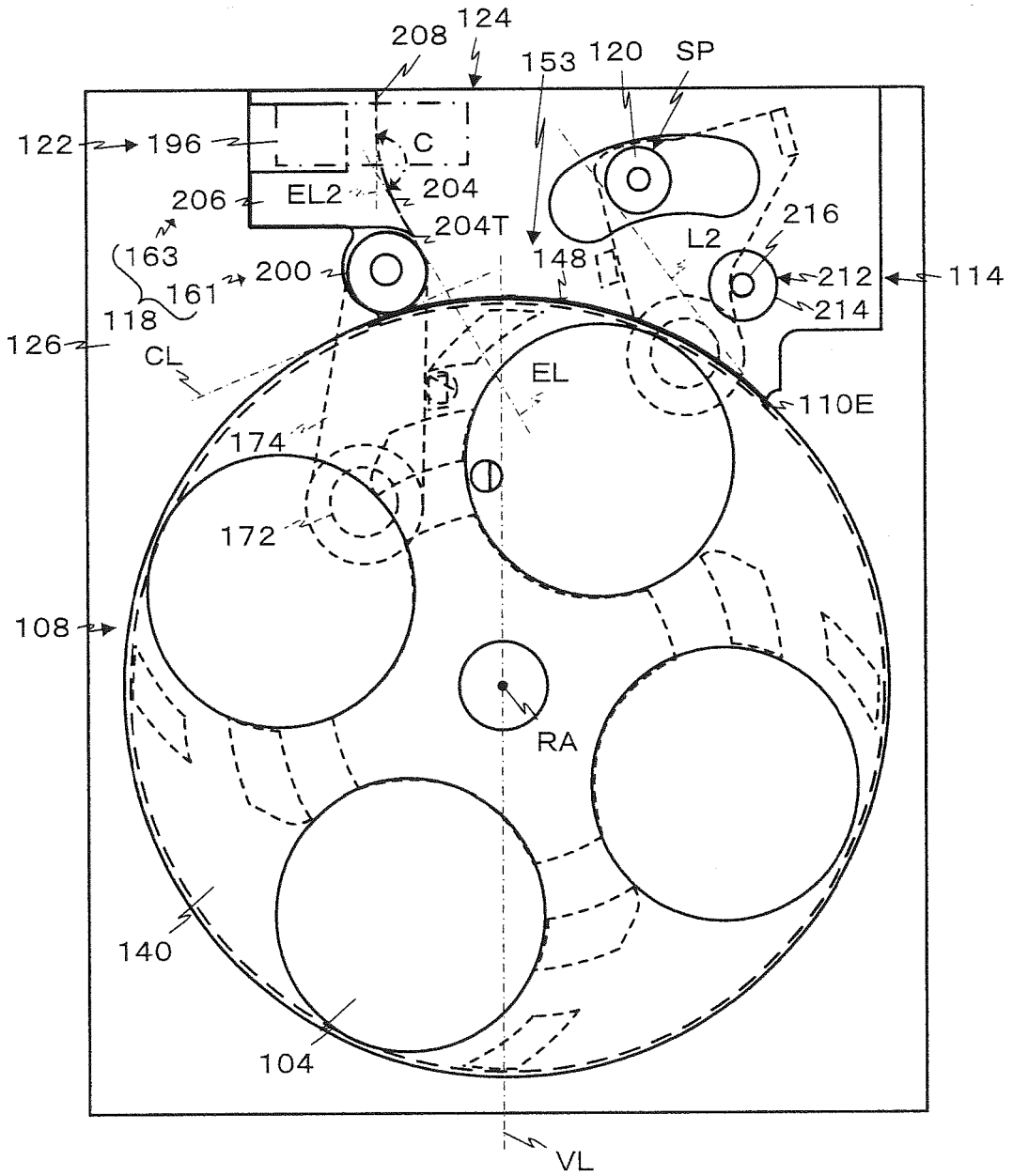

FIG. 16

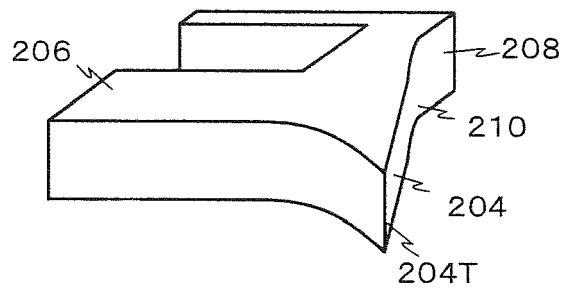

FIG.17

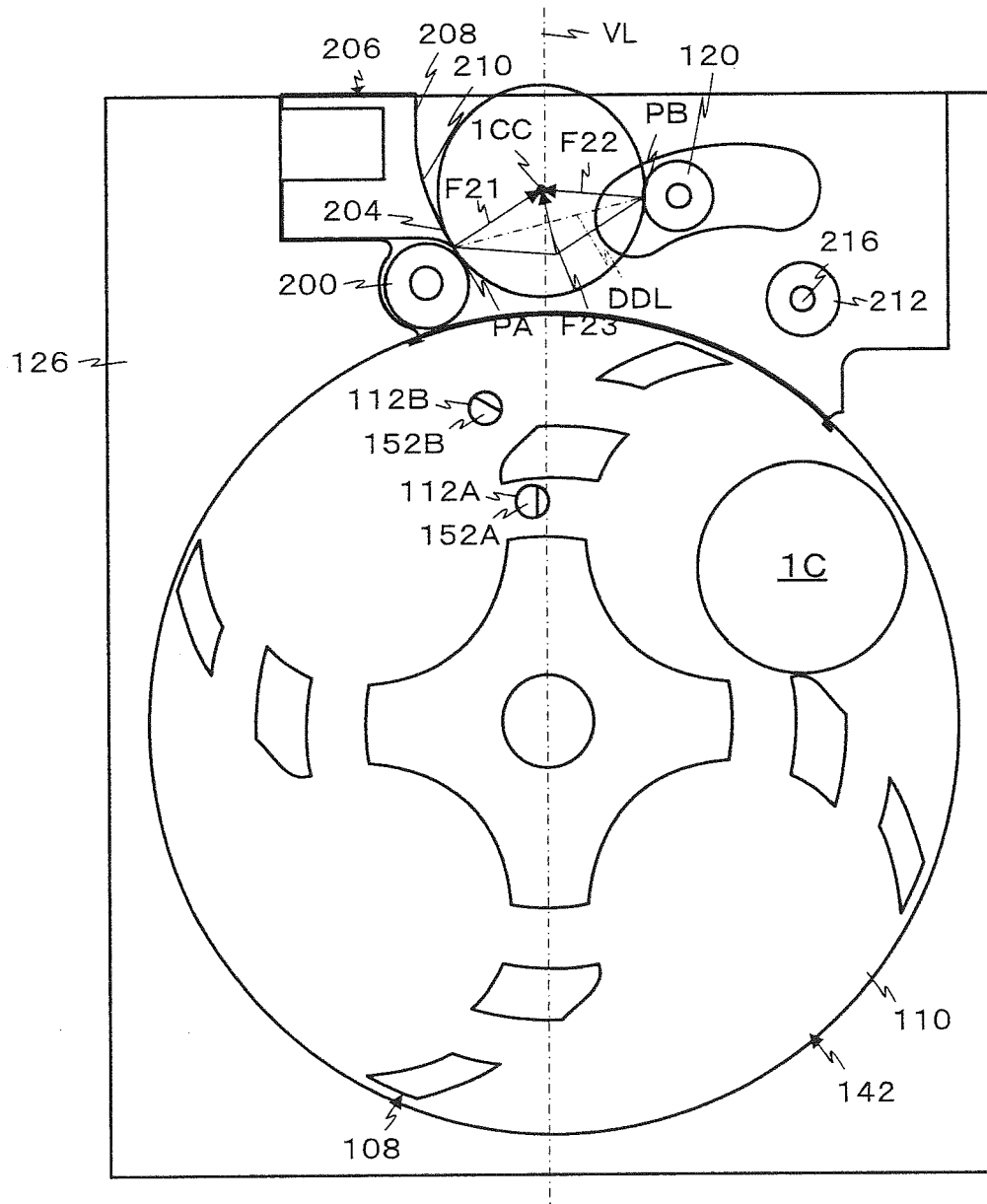
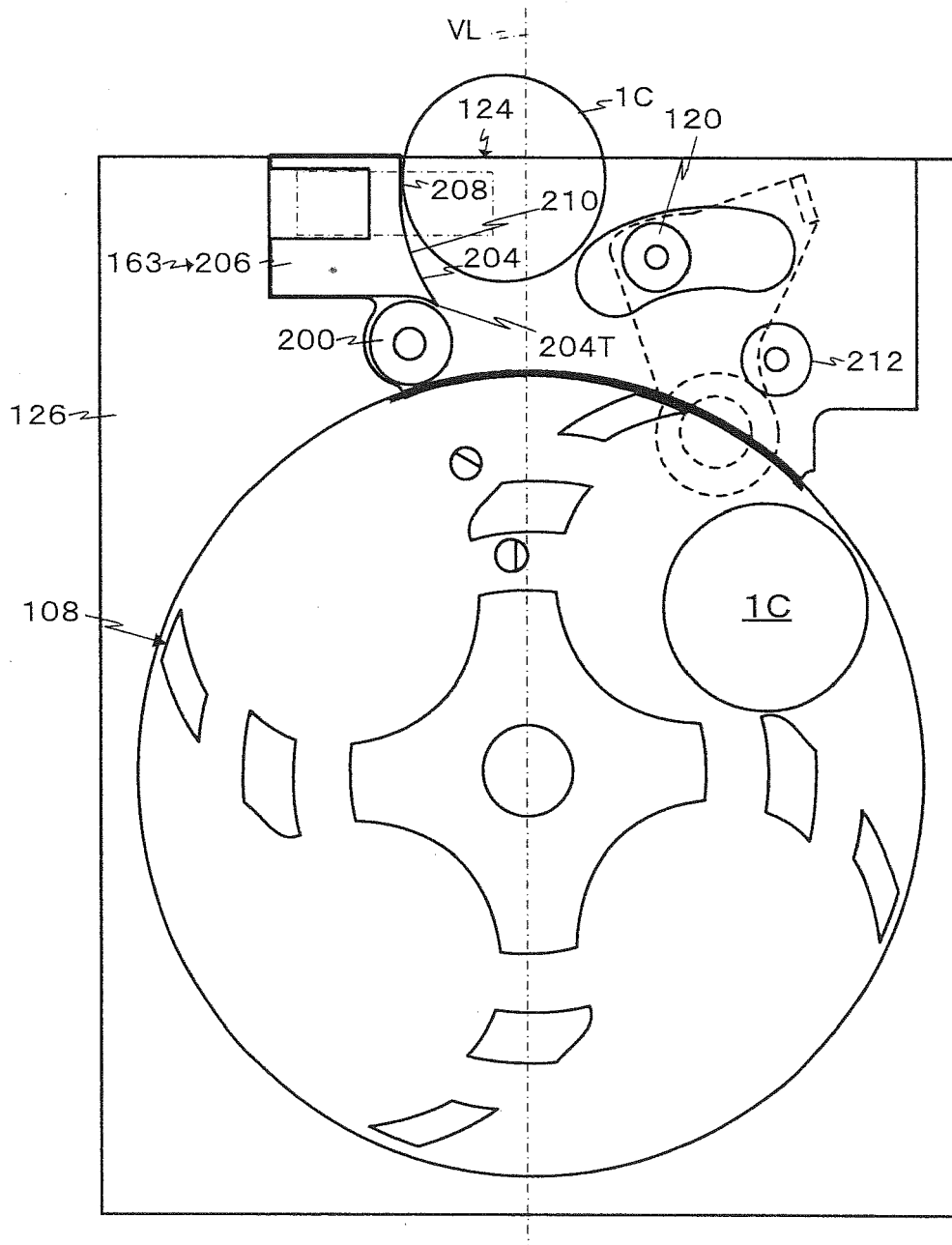

FIG. 18





EUROPEAN SEARCH REPORT

Application Number
EP 14 15 7059

5

10

15

20

25

30

35

40

45

50

55

DOCUMENTS CONSIDERED TO BE RELEVANT			
Category	Citation of document with indication, where appropriate, of relevant passages	Relevant to claim	CLASSIFICATION OF THE APPLICATION (IPC)
X	US 2005/009464 A1 (NIREKI TAKAO [JP] ET AL) 13 January 2005 (2005-01-13) * paragraph [0040] - paragraph [0048] * * figures 2, 3 *	1-3	INV. G07D9/00
X	----- US 5 924 919 A (HIRANO YASUO [JP]) 20 July 1999 (1999-07-20) * column 1, line 5 - column 2, line 27 * * column 4, line 36 - column 5, line 52 * * column 9, line 3 - line 49 * * figures 3, 11 *	1-3	
X	----- US 7 798 304 B2 (TAKEUCHI TORU [JP]) 21 September 2010 (2010-09-21) * column 4, line 32 - column 9, line 40 * * figure 7 *	1-3	
X,D	----- JP 2002 150347 A (ASAHI SEIKO CO LTD) 24 May 2002 (2002-05-24) * the whole document *	1-3	
			TECHNICAL FIELDS SEARCHED (IPC)
			G07D
The present search report has been drawn up for all claims			
Place of search		Date of completion of the search	Examiner
The Hague		12 May 2014	Bohn, Patrice
CATEGORY OF CITED DOCUMENTS		T : theory or principle underlying the invention E : earlier patent document, but published on, or after the filing date D : document cited in the application L : document cited for other reasons & : member of the same patent family, corresponding document	
X : particularly relevant if taken alone Y : particularly relevant if combined with another document of the same category A : technological background O : non-written disclosure P : intermediate document			

1
EPO FORM 1503 03.82 (P04C01)

ANNEX TO THE EUROPEAN SEARCH REPORT
ON EUROPEAN PATENT APPLICATION NO.

EP 14 15 7059

5

This annex lists the patent family members relating to the patent documents cited in the above-mentioned European search report. The members are as contained in the European Patent Office EDP file on The European Patent Office is in no way liable for these particulars which are merely given for the purpose of information.

12-05-2014

10

Patent document cited in search report	Publication date	Patent family member(s)	Publication date
US 2005009464 A1	13-01-2005	AT 371917 T	15-09-2007
		AU 2004202065 A1	02-12-2004
		CN 1551051 A	01-12-2004
		DE 602004008531 T2	27-12-2007
		EP 1477941 A1	17-11-2004
		ES 2293119 T3	16-03-2008
		US 2005009464 A1	13-01-2005

US 5924919 A	20-07-1999	AU 710941 B2	30-09-1999
		AU 1240797 A	07-08-1997
		GB 2309811 A	06-08-1997
		JP 3792766 B2	05-07-2006
		JP H09212700 A	15-08-1997
		US 5924919 A	20-07-1999

US 7798304 B2	21-09-2010	DE 602007000001 T2	24-07-2008
		EP 1811467 A1	25-07-2007
		JP 4849368 B2	11-01-2012
		JP 2007199792 A	09-08-2007
		US 2007170036 A1	26-07-2007

JP 2002150347 A	24-05-2002	CN 1352440 A	05-06-2002
		ES 2184651 A1	01-04-2003
		GB 2369476 A	29-05-2002
		JP 2002150347 A	24-05-2002
		KR 20020035743 A	15-05-2002
		US 2002061724 A1	23-05-2002

20

25

30

35

40

45

50

55

EPO FORM P 0459

For more details about this annex : see Official Journal of the European Patent Office, No. 12/82

REFERENCES CITED IN THE DESCRIPTION

This list of references cited by the applicant is for the reader's convenience only. It does not form part of the European patent document. Even though great care has been taken in compiling the references, errors or omissions cannot be excluded and the EPO disclaims all liability in this regard.

Patent documents cited in the description

- JP 2002150347 A [0003]
- JP 2010262520 A [0003]
- JP 2010131122 A [0004]
- JP 2594435 B [0067]