



(11) **EP 1 441 383 B1**

(12) **EUROPEAN PATENT SPECIFICATION**

(45) Date of publication and mention of the grant of the patent:  
**28.05.2008 Bulletin 2008/22**

(51) Int Cl.:  
**H01J 61/44<sup>(2006.01)</sup> C09K 11/08<sup>(2006.01)</sup>**  
**H01J 61/00<sup>(2006.01)</sup>**

(21) Application number: **03027497.1**

(22) Date of filing: **01.12.2003**

(54) **UV-Emitting phosphor blend and tanning lamp containing same**

UV-emittierende Leuchtstoffmischung und Bräunungslampe diese beinhaltend

Mélange de matière luminescente émettant UV et lampe de bronzage contenant le mélange

(84) Designated Contracting States:  
**AT BE BG CH CY CZ DE DK EE ES FI FR GB GR HU IE IT LI LU MC NL PT RO SE SI SK TR**

(30) Priority: **21.01.2003 US 348468**

(43) Date of publication of application:  
**28.07.2004 Bulletin 2004/31**

(60) Divisional application:  
**05009135.4 / 1 571 692**

(73) Proprietor: **OSRAM SYLVANIA INC.**  
**Danvers, MA 01923 (US)**

(72) Inventors:  
• **Dutta, Arunava**  
**Winchester, MA 01890 (US)**

- **Tetreault, Aline**  
**Quebec J2C 2Z1 (CA)**
- **Dullea, Leonard V.**  
**Peabody, MA 01960 (US)**
- **Horion, Pascal**  
**Quebec Canada J2C 2S8 (CA)**

(74) Representative: **Grünecker, Kinkeldey,**  
**Stockmair & Schwanhäusser**  
**Anwaltssozietät**  
**Leopoldstrasse 4**  
**80802 München (DE)**

(56) References cited:  
**EP-A- 0 806 792 EP-A- 1 160 830**  
**US-A- 3 821 578 US-A- 4 499 403**  
**US-A- 4 645 969 US-A- 4 859 903**  
**US-A- 4 967 090 US-A1- 2002 050 780**

**EP 1 441 383 B1**

Note: Within nine months of the publication of the mention of the grant of the European patent in the European Patent Bulletin, any person may give notice to the European Patent Office of opposition to that patent, in accordance with the Implementing Regulations. Notice of opposition shall not be deemed to have been filed until the opposition fee has been paid. (Art. 99(1) European Patent Convention).

**Description**TECHNICAL FIELD

5 **[0001]** This invention relates to ultraviolet-emitting phosphors and phosphor blends. More, particularly this invention relates to the UVA output and maintenance of tanning lamps.

BACKGROUND OF THE INVENTION

10 **[0002]** Tanning lamps are similar to conventional mercury-vapor fluorescent lamps in construction except that they contain one or more phosphors which emit radiation in the ultraviolet (UV) region of the electromagnetic spectrum in order to induce a tanning response in human skin. The UV emission from tanning lamps is classified into two regions, UVA and UVB. The U.S. Food & Drug Administration (FDA) defines the UVA region as being from 320-400 nm and the UVB region as being from 260-320 nm. (See, *Performance Standards for Light-Emitting Products: Sunlamp Products and Ultraviolet Lamps intended for use in Sunlamp Products*, 21 C.F.R. 1040.20) The majority of the UV flux of tanning lamps is emitted in the UVA region with the balance in the UVB region. This is intended to generally mimic the relative proportions of UVA and UVB in natural sunlight. Both UVA and UVB have a role in the tanning process. When human skin is exposed to UV light, the melanocytes in the skin's epidermis release extra melanin, a protein pigment responsible for tanning. While UVB radiation is more efficient than UVA in stimulating the production of melanin, UVA radiation is much more efficient than UVB in oxidizing the melanin to produce the brown color which is characteristic of suntans.

15 **[0003]** The typical UV-emitting phosphor employed in tanning lamps is a single-component lead-activated barium disilicate,  $\text{BaSi}_2\text{O}_5:\text{Pb}$ . The  $\text{BaSi}_2\text{O}_5:\text{Pb}$  phosphor intrinsically has low maintenance due to its affinity for mercury. Hence, when this phosphor is used in a mercury-vapor fluorescent lamp, the phosphor surface is usually protected by a coating, typically aluminum oxide, as described in U.S. Patent Nos. 4,585,673, 4,710,674, 4,825,124 and 5,523,018. The alumina coating provides a barrier layer between the phosphor and the mercury-vapor and improves long term-UV maintenance.

20 **[0004]** Reflector tanning lamps (RTLs) are a special class of tanning lamps wherein the UV flux is focused by a reflector which causes the flux to be emitted over a narrower segment of the circumference, for example  $140^\circ$ , instead of through the entire  $360^\circ$  circumference of the lamp. Two key performance parameters of tanning lamps, and RTLs in particular, are the initial UVA output of the lamp and the UVA maintenance. The initial UVA output of the lamp (0 hours) will be herein referred to as the 0h UVA output. The UVA maintenance measures the ability of the lamp to maintain its initial UVA output over a period of time, usually the first 100 hours of operation, and is expressed as a percentage of the initial output. As used herein, the 100h UVA maintenance is defined as the ratio of the UVA output of the lamp after 100 hours of operation to its initial UVA output times 100% ( $(100\text{h UVA output}/0\text{ UVA output}) \times 100\%$ ). For commercial applications, it is very desirable to have both a high 0h UVA output and a high 100h UVA maintenance. Unfortunately, current commercial RTLs either have a high 0h UVA output ( $\geq 8600\ \mu\text{W}/\text{cm}^2$ ) or a high 100h UVA maintenance ( $\geq 87\%$ ) but not both attributes simultaneously. In other words, RTLs that have a high 100h UVA maintenance ( $\geq 87\%$ ) have a 0h UVA output that is much less than  $8600\ \text{mW}/\text{cm}^2$ . Conversely, RTLs that have a high UVA output ( $\geq 8600\ \text{mW}/\text{cm}^2$ ) have a 100h UVA maintenance that is much less than 87%. The inverse relationship between 0h UVA output and 100h UVA maintenance for commercial reflector tanning lamps is shown in Fig. 1.

30 **[0005]** Therefore, it would be an advantage over the present state of the art to have tanning lamps, and RTLs in particular, that exhibit higher 0h UVA outputs at high 100h UVA maintenances.

35 **[0006]** Lamps containing UV-emitting phosphors are also used for other purposes. US 4,859,903 discloses an ultraviolet lamp for accelerated testing on polymers. For this purpose the lamp has to have a spectral distribution similar to that of sunlight. In one embodiment a blend of UV-emitting phosphors consisting of  $\text{LaPO}_4:\text{Ce}$ ,  $\text{SrB}_4\text{O}_7:\text{Eu}$ , and  $\text{BaSi}_2\text{O}_5:\text{Pb}$  is used in a bulb of ultraviolet transmitting glass.

SUMMARY OF THE INVENTION

40 **[0007]** It is an object of the invention to obviate the disadvantages of the prior art.

50 **[0008]** It is another object of the invention to provide tanning lamps having higher 0h UVA outputs at high 100h UVA maintenances.

**[0009]** In accordance with one aspect of the invention, there is provided a UV-emitting phosphor blend which comprises a mixture of at least two UVA-emitting phosphors selected from  $\text{SrB}_4\text{O}_7:\text{Eu}$ ,  $\text{YPO}_4:\text{Ce}$ , and  $\text{BaSi}_2\text{O}_5:\text{Pb}$ , wherein the sum of the weight percentages of the phosphors in the mixture equals 100%. The phosphor blend additionally contains an optional amount of  $\text{SrCe}_{0.08}\text{MgAl}_{11}\text{O}_{18}$  having a range from 0 to 12 wt.% of the mixture.

55 **[0010]** In accordance with another aspect of the invention, there is envelope and a phosphor coating on an inner wall of the envelope. The phosphor coating contains a UV-emitting phosphor blend comprising a mixture of at least two UVA-emitting phosphors selected from  $\text{SrB}_4\text{O}_7:\text{Eu}$ ,  $\text{YPO}_4:\text{Ce}$ , and  $\text{BaSi}_2\text{O}_5:\text{Pb}$ . The phosphor blend additionally contains an

optional amount of  $\text{SrCe}_{0.08}\text{MgAl}_{11}\text{O}_{18}$  having a range from 0 to 12 wt.% of the mixture.

**[0011]** In accordance with a further aspect of the invention, there is provided a fluorescent tanning lamp having a tubular UV-transmissive envelope, a reflector layer, and a UV-emitting phosphor layer. The reflector layer extends over a 220° segment of the circumference of the envelope and is disposed between the envelope and the phosphor layer. The phosphor layer extends over the entire circumference of the envelope and the lamp exhibits a 0h UVA output of at least about 8800  $\mu\text{W}/\text{cm}^2$  and a 100h UVA maintenance of at least about 87%.

#### BRIEF DESCRIPTION OF THE DRAWINGS

##### **[0012]**

Fig. 1 is a graph of the relationship between the 0h UVA output and the 100h UVA maintenance of commercial reflector tanning lamps.

Fig. 2 is a contour plot of the 0h UVA output of several groups of tanning lamps containing various UV-emitting phosphor blends.

Fig. 3 is a contour plot of the 100h UVA maintenance of several groups of tanning lamps containing various UV-emitting phosphor blends.

Fig. 4 is a graphical illustration of the preferred UV-emitting blend compositions of the present invention.

Fig. 5 is a cross-sectional illustration of a reflector tanning lamp.

#### DETAILED DESCRIPTION OF THE INVENTION

**[0013]** For a better understanding of the present invention, together with other and further objects, advantages and capabilities thereof, reference is made to the following disclosure and appended claims taken in conjunction with the above-described drawings.

**[0014]** We have discovered that it is possible to simultaneously achieve a high 0h UVA output at a high 100h UVA maintenance by using a blend containing a mixture of at least two UV-emitting phosphors selected from the group comprising  $\text{SrB}_4\text{O}_7:\text{Eu}$ ,  $\text{YPO}_4:\text{Ce}$ , and  $\text{BaSi}_2\text{O}_5:\text{Pb}$ . All three phosphors in the group emit radiation in the UVA region. The first phosphor,  $\text{SrB}_4\text{O}_7:\text{Eu}$ , exhibits an emission spectrum which peaks at 368 nm. The second phosphor,  $\text{YPO}_4:\text{Ce}$ , exhibits a bimodal emission spectrum with local peaks at 338 and 356 nm. The third phosphor,  $\text{BaSi}_2\text{O}_5:\text{Pb}$ , has an emission spectrum that peaks at 351 nm. As described previously, the  $\text{BaSi}_2\text{O}_5:\text{Pb}$  phosphor is the phosphor of choice in current state-of-the-art RTL applications. For example, all of the lamps shown in Fig. 1 use this phosphor at 100%. Although not required for this invention, it is preferred that an alumina coating be applied to the  $\text{BaSi}_2\text{O}_5:\text{Pb}$  phosphor.

**[0015]** The UV-emitting blend may additionally contain an amount of  $\text{SrCe}_{0.08}\text{MgAl}_{11}\text{O}_{18}$ , a phosphor which emits in the UVB region at 310.5 nm. The amount of this phosphor may range from 0-12 weight percent (wt.%) based on the combined weight of the UVA-emitting phosphors in the blend.

**[0016]** In a first alternate embodiment, the UV-emitting phosphor blend of this invention comprises a mixture of  $\text{BaSi}_2\text{O}_5:\text{Pb}$  and at least one phosphor selected from  $\text{SrB}_4\text{O}_7:\text{Eu}$  and  $\text{YPO}_4:\text{Ce}$ . The relative proportions of the phosphors in the mixture range from 0 to 50 wt.%  $\text{SrB}_4\text{O}_7:\text{Eu}$ , 0 to 40 wt.%  $\text{YPO}_4:\text{Ce}$ , and 30 to 70 wt.%  $\text{BaSi}_2\text{O}_5:\text{Pb}$  wherein the sum of the weight percentages equals 100%. Preferably, the relative proportions of the UVA-emitting phosphors in the mixture range from 30 to 40 wt.%  $\text{SrB}_4\text{O}_7:\text{Eu}$ , 30 to 40 wt.%  $\text{YPO}_4:\text{Ce}$ , and 30 to 40 wt.%  $\text{BaSi}_2\text{O}_5:\text{Pb}$ . More preferably, the proportions range from 30 to 35 wt.%  $\text{SrB}_4\text{O}_7:\text{Eu}$ , 30 to 35 wt.%  $\text{YPO}_4:\text{Ce}$ , and 30 to 35 wt.%  $\text{BaSi}_2\text{O}_5:\text{Pb}$ . And most preferably, the proportions of the mixture are about 33.3 wt.%  $\text{SrB}_4\text{O}_7:\text{Eu}$ , about 33.3 wt.%  $\text{YPO}_4:\text{Ce}$ , and about 33.3 wt.%  $\text{BaSi}_2\text{O}_5:\text{Pb}$ . In each of the above cases, the UV-emitting phosphor blend may additionally contain an optional amount of the UVB-emitting  $\text{SrCe}_{0.08}\text{MgAl}_{11}\text{O}_{18}$  phosphor in an amount from 0 to 12 wt.% of the mixture of UVA-emitting phosphors.

**[0017]** In a second alternate embodiment, the UV-emitting phosphor blend comprises a mixture of  $\text{BaSi}_2\text{O}_5:\text{Pb}$  and at least one phosphor selected from  $\text{SrB}_4\text{O}_7:\text{Eu}$  and  $\text{YPO}_4:\text{Ce}$ , wherein the relative proportions of the mixture range from 0 to 20 wt.%  $\text{SrB}_4\text{O}_7:\text{Eu}$ , 0 to 20 wt.%  $\text{YPO}_4:\text{Ce}$ , and 50 to 70 wt.%  $\text{BaSi}_2\text{O}_5:\text{Pb}$  and the sum of the weight percentages of the phosphors in the mixture equals 100%. Preferably, the relative proportions of the UVA-emitting phosphors range from 15 to 20 wt.%  $\text{SrB}_4\text{O}_7:\text{Eu}$ , 15 to 20 wt.%  $\text{YPO}_4:\text{Ce}$ , and 65 to 70 wt.%  $\text{BaSi}_2\text{O}_5:\text{Pb}$ . More preferably, the proportions are about 16.7 wt.%  $\text{SrB}_4\text{O}_7:\text{Eu}$ , about 16.7 wt.%  $\text{YPO}_4:\text{Ce}$ , and about 66.6 wt.%  $\text{BaSi}_2\text{O}_5:\text{Pb}$ . Again, in each instance, the UV-emitting phosphor blend may additionally contain  $\text{SrCe}_{0.08}\text{MgAl}_{11}\text{O}_{18}$  in an amount from 0 to 12 wt.% of the mixture of UVA-emitting phosphors.

## EP 1 441 383 B1

**[0018]** In a third alternate embodiment, the UV-emitting phosphor blend comprises a mixture of  $\text{BaSi}_2\text{O}_5\text{:Pb}$  and  $\text{SrB}_4\text{O}_7\text{:Eu}$ , wherein the relative proportions range from 40 to 60 wt.%  $\text{SrB}_4\text{O}_7\text{:Eu}$  and 40 to 60 wt.%  $\text{BaSi}_2\text{O}_5\text{:Pb}$  and the sum of their weight percentages equals 100%. Preferably, the relative proportions range from 45 to 55 wt.%  $\text{SrB}_4\text{O}_7\text{:Eu}$  and 45 to 55 wt.%  $\text{BaSi}_2\text{O}_5\text{:Pb}$ . More preferably, the mixture comprises about 50% wt.%  $\text{SrB}_4\text{O}_7\text{:Eu}$  and about 50 wt.%  $\text{BaSi}_2\text{O}_5\text{:Pb}$ . As above, the phosphor blend may additionally contain  $\text{SrCe}_{0.08}\text{MgAl}_{11}\text{O}_{18}$  in an amount from 0 to 12 wt.% of the mixture of UVA-emitting phosphors.

**[0019]** In a fourth alternate embodiment, the UV-emitting phosphor blend comprises a mixture of  $\text{YPO}_4\text{:Ce}$  and  $\text{SrB}_4\text{O}_7\text{:Eu}$ , wherein the relative proportions of the phosphors range from 40 to 60 wt.%  $\text{SrB}_4\text{O}_7\text{:Eu}$  and 40 to 60 wt.%  $\text{YPO}_4\text{:Ce}$  and the sum of their weight percentages equals 100%. Preferably, this mixture comprises 45 to 55 wt.%  $\text{SrB}_4\text{O}_7\text{:Eu}$  and 45 to 55 wt.%  $\text{YPO}_4\text{:Ce}$ . More preferably, the mixture comprises about 50% wt.%  $\text{SrB}_4\text{O}_7\text{:Eu}$  and about 50 wt.%  $\text{YPO}_4\text{:Ce}$ . As above, the phosphor blend may additionally contain  $\text{SrCe}_{0.08}\text{MgAl}_{11}\text{O}_{18}$  in an amount from 0 to 12 wt.% of the mixture of UVA-emitting phosphors.

**[0020]** The following nonlimiting examples are presented.

### EXAMPLES

**[0021]** A number of reflector tanning lamps were made which contained various combinations of the four UV-emitting phosphors used in the UV-emitting blends of this invention. All the four UV-emitting phosphors were manufactured by OSRAM SYLVANIA Products Inc., Towanda, Pennsylvania.  $\text{SrB}_4\text{O}_7\text{:Eu}$  is designated as OSRAM SYLVANIA Type 2052,  $\text{BaSi}_2\text{O}_5\text{:Pb}$  (coated with  $\text{Al}_2\text{O}_3$ ) as OSRAM SYLVANIA Type GS2016,  $\text{YPO}_4\text{:Ce}$  as OSRAM SYLVANIA Type 2040, and  $\text{SrCe}_{0.08}\text{MgAl}_{11}\text{O}_{18}$  as OSRAM SYLVANIA Type 2096. The physical properties of the phosphors are given in Table 1. Particle size distribution was measured by a Coulter LS130 laser diffraction system.

Table 1

Phosphor	50% Size ( $\mu\text{m}$ )	BET Surface Area ( $\text{m}^2/\text{g}$ )	Density ( $\text{g}/\text{cm}^3$ )
$\text{SrB}_4\text{O}_7\text{:Eu}$	9.9	0.61	3.4
$\text{YPO}_4\text{:Ce}$	13.5	0.69	4.24
$\text{BaSi}_2\text{O}_5\text{:Pb}$	11.2	0.65	3.9
$\text{SrCe}_{0.08}\text{MgAl}_{11}\text{O}_{18}$	12.9	0.91	3.5

**[0022]** The effect of the blend composition on the 0h UVA output and 100h UVA maintenance of the lamps may be demonstrated with a Simplex-Centroid design. In particular, the blend composition was varied such that the sum of the mass fractions of the three UVA-emitting phosphors,  $\text{SrB}_4\text{O}_7\text{:Eu}$ ,  $\text{YPO}_4\text{:Ce}$  and  $\text{BaSi}_2\text{O}_5\text{:Pb}$ , added up to unity. The Simplex-Centroid design for the three UVA-emitting phosphors results in a total of ten blends for which the relative amounts of each phosphor are given in Table 2. Each of these ten blends also contained a fixed amount of the UVB-emitting phosphor,  $\text{SrCe}_{0.08}\text{MgAl}_{11}\text{O}_{18}$ , which was 4 wt.% of the mixture of UVA-emitting phosphors. Blend 11 was used as a separate control and contained only the  $\text{BaSi}_2\text{O}_5\text{:Pb}$  phosphor.

Table 2

Blend/Group	$\text{SrB}_4\text{O}_7\text{:Eu}$	$\text{YPO}_4\text{:Ce}$	$\text{BaSi}_2\text{O}_5\text{:Pb}$
1	1	0	0
2	0	1	0
3	0	0	1
4	0.5	0.5	0
5	0.5	0	0.5
6	0	0.5	0.5
7	0.3333	0.3333	0.3333
8	0.6667	0.1667	0.1667
9	0.1667	0.6667	0.1667
10	0.1667	0.1667	0.6667

(continued)

Blend/Group	SrB <sub>4</sub> O <sub>7</sub> :Eu	YPO <sub>4</sub> :Ce	BaSi <sub>2</sub> O <sub>5</sub> :Pb
11 (Control)	0	0	1

5  
10  
15  
[0023] These blends are represented in the triangular composition diagrams shown in Figs. 2-4. Blends 1-3 (Gr 1-3) occupy the vertices of the ternary diagrams. Blends 4 to 6 (Gr 4-6) occupy the mid-points of the three sides of the triangles. For example, blend 5 contains a 50:50 mixture of SrB<sub>4</sub>O<sub>7</sub>:Eu and BaSi<sub>2</sub>O<sub>5</sub>:Pb and is located exactly halfway between the vertices representing SrB<sub>4</sub>O<sub>7</sub>:Eu and BaSi<sub>2</sub>O<sub>5</sub>:Pb. Blends 7 to 10 (Gr 7-10) contain mixtures of SrB<sub>4</sub>O<sub>7</sub>:Eu, YPO<sub>4</sub>:Ce and BaSi<sub>2</sub>O<sub>5</sub>:Pb. In particular, blend 7 is the centroid which is located at the point of intersection of the medians of the triangle. At the centroid, each of the three phosphors is a third of the mixture. Blends 8 to 10 are called axial points and are located on the median lines of the triangle such that one of the components is 2/3 of the mixture while the other two are a sixth each. It is important to remember that each of the ten blends contains 4 wt.% SrCe<sub>0.08</sub>MgAl<sub>11</sub>O<sub>18</sub> wherein the weight percentage is calculated based on the combined weight of the mixture of UVA-emitting phosphors.

#### Coating Suspensions and Bulb Coating

20  
25  
[0024] Organic-based coating suspensions were made using conventional suspension components. These included, in addition to the phosphor blend, a solvent, a polymeric binder, a dispersing agent, a plasticizer and adherence agents. A preferred suspension includes xylene as the solvent, ethyl cellulose as the binder, and benzoic acid and Armeen CD, a primary amine made by Akzo Nobel Chemicals, as the dispersing agent combination. In addition, dibutyl phthalate is a common plasticizer and finely divided aluminum oxide (Aluminum Oxide C from Degussa AG) serves as a good adherence agent.

[0025] Standard six-foot T12 (1.5 in. O.D.) bulbs with a pre-coated alumina reflector covering about 220° of the circumference were used. The phosphor suspension was manually applied over the interior surface using a combination of axial and rotational motions. The coated bulb was then allowed to drain and dry for about 30 minutes yielding a phosphor coating having a total loading of about 8.5 g of phosphor.

#### Lamp Finishing

30  
35  
[0026] The lamps were then loaded into a baker where the residual organic components in the coating were combusted in the presence of air. Electrode mounts were sealed into each end of the baked bulbs. The lamps were then preheated and exhausted through exhaust tubes in the electrode mounts. Mercury and a fill gas were introduced into the lamps and the exhaust tubes were sealed. The fill pressure was 1.8 torr for the ten test groups and 2.7 torr for the control group. The fill gas in all cases was a 70/30 neon-argon mixture. Mercury dosing was 18 mg. Conventional lamp bases were there attached to the lamps. The wattages of the test groups ranged from a low of 167.3 W to a high of 170.2 W whereas the control group wattage was 170.9 W.

40  
[0027] A cross-sectional illustration of a finished reflector lamp is shown in Fig. 5. The lamp UV-transmissive envelope 3 has a partial alumina reflector coating 5 which extends over about 220° of the circumference. The phosphor coating 7 is disposed on top of the reflector coating 5 and extends over the entire circumference of the envelope 3 including the 140° segment 9 where there is no reflector coating.

45  
50  
[0028] Several lamps were made with each phosphor blend. The UV output of each group of test lamps was corrected for the difference in wattages between the test group and the control group. This was done by (1) computing the UV output per watt for each test group, (2) multiplying that value by the wattage differential between each test group and the control group 11, and (3) adding the result to the original UV flux value for the test group. A second correction factor was then applied to account for differences between the experimental measurement setup used for these lamps and a typical measurement setup used for commercial lamps. One of the reasons for the different experimental setup used here was that the UV output from some of lamps was too high to permit the measurement to be made at the normal 10 cm distance from the lamp centerline. A second reason was that a different lamp stabilization method was adopted for these tests that increased the signal-to-noise ratio of the photometric measurement.

55  
[0029] After determining the initial UVA output, five lamps per group were aged to 100h and then the UVA output was measured again. The 100h UVA maintenance was then computed for each of the lamps in all groups. As described previously, the 100h UVA maintenance is defined as the ratio of 100h UVA output to 0h UVA output with the ratio being multiplied by 100 to express it as a percentage. The 100h maintenance of each group was then adjusted by normalizing the maintenance of the control group to 85% which is typical for this lamp. The mean 0h UVA output and 100h UVA maintenance of the groups is shown in Table 3.

Table 3

Group/Blend	Corrected 0h UVA Output ( $\mu\text{W}/\text{cm}^2$ )	Normalized 100h UVA Maintenance (%)
1	7364	91.3
2	7816	87.1
3	8641	84.7
4	7887	92.3
5	9099	89.6
6	8790	84.5
7	8816	90.5
8	8409	89.7
9	8525	87.8
10	8896	87.2
11 (Control)	8388	85.0

**[0030]** From the data in Table 3, it is possible to construct contour diagrams in the triangular composition space. Referring to Fig. 2, there is shown a contour plot for the 0h UVA output. Each contour line connects those compositions which have the same 0h UVA output. The 0h UVA output associated with each contour line is given in  $\mu\text{W}/\text{cm}^2$ .

**[0031]** It is apparent that a higher 0h UVA output is favored by compositions that lie closer to the  $\text{SrB}_4\text{O}_7\text{:Eu-BaSi}_2\text{O}_5\text{:Pb}$  binary line. The blends having the three highest 0h UVA outputs in the Simplex-Centroid design were blends 5, 10 and 7 with 0h UVA outputs of 9100, 8896 and 8816  $\mu\text{W}/\text{cm}^2$  respectively. These outputs exceed the 0h UVA output of the control group 11 by 8.5%, 6%, and 5.1%, respectively. These increases are greater than the approximate 3% increase which is attributable to the lower fill pressure of the test lamps. The increase in the 0h UVA output caused by the lower fill pressure alone can be seen by comparing the 0h UVA outputs of groups 3 and 11.

**[0032]** Blend 5 contains no  $\text{YPO}_4\text{:Ce}$  and its 0h UVA output greatly exceeds the mean 0h UVA output of blends 1 and 3 which represent single-component mixtures of each phosphor in blend 5. This indicates that there is a synergism between the  $\text{SrB}_4\text{O}_7\text{:Eu}$  and  $\text{BaSi}_2\text{O}_5\text{:Pb}$  components which cannot be attributed to wattage or powder weight issues. While not wishing to be bound by theory, a possible explanation for the synergy between the  $\text{SrB}_4\text{O}_7\text{:Eu}$  and  $\text{BaSi}_2\text{O}_5\text{:Pb}$  phosphors may be deduced from the observed overlap between the emission spectrum of the  $\text{BaSi}_2\text{O}_5\text{:Pb}$  phosphor and the excitation spectrum of the  $\text{SrB}_4\text{O}_7\text{:Eu}$  phosphor. The excitation spectrum for  $\text{SrB}_4\text{O}_7\text{:Eu}$  extends up to about 360 nm and the broad emission from  $\text{BaSi}_2\text{O}_5\text{:Pb}$  peaks at about 350 nm. This means that a portion of the emission from the  $\text{BaSi}_2\text{O}_5\text{:Pb}$  phosphor excites the  $\text{SrB}_4\text{O}_7\text{:Eu}$  phosphor which then emits according to its characteristic emission spectrum which peaks at 368nm. The overlap of the excitation and emission spectra coupled with quantum efficiency considerations of individual phosphor components may explain the significant synergy identified for the  $\text{SrB}_4\text{O}_7\text{:Eu-BaSi}_2\text{O}_5\text{:Pb}$  system.

**[0033]** A similar contour plot was constructed for the 100h UVA maintenance. Referring to Fig. 3, the contour lines define the range of compositions having the same 100h UVA maintenance value. The maintenance value associated with each contour line is given in terms of %. The plot shows that higher 100h UVA maintenance values are favored by blend compositions that lie closer to the  $\text{SrB}_4\text{O}_7\text{:Eu-YPO}_4\text{:Ce}$  composition line. The highest 100h UVA maintenance is observed with blend 4 which contains equal amounts of  $\text{SrB}_4\text{O}_7\text{:Eu}$  and  $\text{YPO}_4\text{:Ce}$ . The plot shows that increasing the amount of  $\text{BaSi}_2\text{O}_5\text{:Pb}$  phosphor in the blend lowers the 100h UVA maintenance.

**[0034]** From Figs. 2 and 3, it is clear that the blend composition space that favors a high 0h UVA output is different from the space that is optimal for high 100h UVA maintenance. Therefore, there must be a joint optimization of the two responses. This was done with the help of an overlaid contour plot, Fig. 4, wherein the lower boundary for the 0h UVA response was specified at about 8800  $\mu\text{W}/\text{cm}^2$  and lower boundary for the 100h UVA maintenance response was specified at about 87%. The cross-hatched region in Fig. 4 is where the two responses overlap. This region represents those blend compositions that result in simultaneous high values of 0h UVA output and 100h UVA maintenance. It can be seen that the blends 5, 7 and 10 fall within this region.

**[0035]** The performance of these three blends can be put in perspective when they are compared with the current state of the art represented by control group 11. The lamps in the control group exhibit a 0h UVA output of 8388  $\mu\text{W}/\text{cm}^2$  and a 100h UVA maintenance of 85%. The lamps in group 5 exhibit a 0h UVA output of 9099  $\mu\text{W}/\text{cm}^2$  and a 100h UVA maintenance of 89.6%. This represents a gain of 8.5% in 0h UVA output and an increase of almost 5 percentage points

in 100h UVA maintenance. Similarly, the lamps in groups 7 and 10 represent a gain of about 5-6% in 0h UVA output and an increase of about 2 to more than 4 percentage points in 100h UVA maintenance. As discussed previously, these gains in 0h output are greater than the 3% increase attributable to the lower fill pressure of the test lamps. Thus, the UV-emitting blends of this invention have been shown to exhibit higher 0h UVA outputs at high 100h UVA maintenance values.

**[0036]** It is also worth noting at this point that blend 4 which has a lower 0h UVA output than the control group is nevertheless commercially important because of its very high 100h UVA maintenance. Even though the 0h UVA output of blend 4 is 7887  $\mu\text{W}/\text{cm}^2$  compared to 8388  $\mu\text{W}/\text{cm}^2$  for the control, the much higher 100h UVA maintenance of 92.3% for blend 4 means that at 100 hours the UVA output of blend 4 (7280  $\mu\text{W}/\text{cm}^2$ ) exceeds that of the control (7130  $\mu\text{W}/\text{cm}^2$ ). Therefore, blend 4 would be very desirable for applications in which a very high maintenance is needed.

**[0037]** Blends 1, 2, 3 and 6 are not part of the claimed invention and should be regarded as comparative examples.

**[0038]** While there has been shown and described what are at the present considered the preferred embodiments of the invention, it will be obvious to those skilled in the art that various changes and modifications may be made therein without departing from the scope of the invention as defined by the appended claims.

## Claims

1. A UV-emitting phosphor blend comprising:

a mixture of UVA-emitting phosphors comprising 0 to 50 wt.%  $\text{SrB}_4\text{O}_7:\text{Eu}$ , 0 to 40 wt.%  $\text{YPO}_4:\text{Ce}$ , and 30 to 70 wt.%  $\text{BaSi}_2\text{O}_5:\text{Pb}$ ,

wherein the sum of the weight percentages of the phosphors in the mixture equals 100%, and the phosphor blend additionally contains an optional amount of  $\text{SrCe}_{0.08}\text{MgAl}_{11}\text{O}_{18}$  having a range from 0 to 12 wt.% of the mixture.

2. The phosphor blend of claim 1 wherein the mixture of UVA-emitting phosphors comprises 30 to 40 wt.%  $\text{SrB}_4\text{O}_7:\text{Eu}$ , 30 to 40 wt.%  $\text{YPO}_4:\text{Ce}$ , and 30 to 40 wt.%  $\text{BaSi}_2\text{O}_5:\text{Pb}$ .

3. The phosphor blend of claim 1 wherein the mixture of UVA-emitting phosphors comprises 30 to 35 wt.%  $\text{SrB}_4\text{O}_7:\text{Eu}$ , 30 to 35 wt.%  $\text{YPO}_4:\text{Ce}$ , and 30 to 35 wt.%  $\text{BaSi}_2\text{O}_5:\text{Pb}$ .

4. The phosphor blend of claim 1 wherein the mixture of UVA-emitting phosphors comprises about 33.3 wt.%  $\text{SrB}_4\text{O}_7:\text{Eu}$ , about 33.3 wt.%  $\text{YPO}_4:\text{Ce}$ , and about 33.3 wt.%  $\text{BaSi}_2\text{O}_5:\text{Pb}$ .

5. The phosphor blend of claim 1 wherein the mixture of UVA-emitting phosphors comprises 0 to 20 wt.%  $\text{SrB}_4\text{O}_7:\text{Eu}$ , 0 to 20 wt.%  $\text{YPO}_4:\text{Ce}$ , and 50 to 70 wt.%  $\text{BaSi}_2\text{O}_5:\text{Pb}$ .

6. The phosphor blend of claim 1 wherein the mixture of UVA-emitting phosphors comprises 15 to 20 wt.%  $\text{SrB}_4\text{O}_7:\text{Eu}$ , 15 to 20 wt.%  $\text{YPO}_4:\text{Ce}$ , and 65 to 70 wt.%  $\text{BaSi}_2\text{O}_5:\text{Pb}$ .

7. The phosphor blend of claim 1 wherein the mixture of UVA-emitting phosphors comprises about 16.7 wt.%  $\text{SrB}_4\text{O}_7:\text{Eu}$ , about 16.7 wt.%  $\text{YPO}_4:\text{Ce}$ , and about 66.6 wt.%  $\text{BaSi}_2\text{O}_5:\text{Pb}$ .

8. The phosphor blend of claim 1 wherein the mixture of UVA-emitting phosphors comprises about 50 wt.%  $\text{SrB}_4\text{O}_7:\text{Eu}$  and about 50 wt.%  $\text{BaSi}_2\text{O}_5:\text{Pb}$ .

9. A fluorescent tanning lamp having:

a UV-transmissive envelope (3); and  
a phosphor coating (7) on an inner wall of the envelope (3),  
the phosphor coating (7) containing a UV-emitting phosphor blend comprising:

a mixture of at least two UVA-emitting phosphors selected from  $\text{SrB}_4\text{O}_7:\text{Eu}$ ,  $\text{YPO}_4:\text{Ce}$ , and  $\text{BaSi}_2\text{O}_5:\text{Pb}$ , the phosphor blend additionally containing an optional amount of  $\text{SrCe}_{0.08}\text{MgAl}_{11}\text{O}_{18}$  having a range from 0 to 12 wt.% of the mixture,

wherein the lamp exhibits a 100h UVA maintenance of at least 87%.

10. The fluorescent lamp of claim 9 wherein the lamp exhibits a 0h UVA output of at least 8800  $\mu\text{W}/\text{cm}^2$ .
- 5 11. The fluorescent lamp of claim 9 wherein the mixture of UVA-emitting phosphors comprises 40 to 60 wt.%  $\text{SrB}_4\text{O}_7$ :Eu and 40 to 60 wt.%  $\text{YPO}_4$ :Ce.
12. The fluorescent lamp of claim 10 wherein the mixture of UVA-emitting phosphors comprises 0 to 50 wt.%  $\text{SrB}_4\text{O}_7$ :Eu, 0 to 40 wt.%  $\text{YPO}_4$ :Ce, and 30 to 70 wt.%  $\text{BaSi}_2\text{O}_5$ :Pb.
- 10 13. The fluorescent lamp of claim 10 wherein the mixture of UVA-emitting phosphors comprises 0 to 20 wt.%  $\text{SrB}_4\text{O}_7$ :Eu, 0 to 20 wt.%  $\text{YPO}_4$ :Ce, and 50 to 70 wt.%  $\text{BaSi}_2\text{O}_5$ :Pb.
14. The fluorescent lamp of claim 10 wherein the mixture of UVA-emitting phosphors comprises 40 to 60 wt.%  $\text{SrB}_4\text{O}_7$ :Eu and 40 to 60 wt.%  $\text{BaSi}_2\text{O}_5$ :Pb.
- 15 15. The fluorescent lamp of claim 10 wherein the envelope (3) is tubular and further contains a reflector layer (5) extending over a 220° segment of the circumference of the envelope (3), the reflector layer (5) being disposed between the envelope (3) and the phosphor layer (7),
- 20 the phosphor layer (7) extending over the entire circumference of the envelope (3).

### Patentansprüche

- 25 1. Ultraviolett emittierendes Leuchtstoffgemisch, das umfasst:
- eine Mischung aus UVA-emittierendem Leuchtstoff, die 0 bis 50 Gew.-%  $\text{SrB}_4\text{O}_7$ :Eu, 0 bis 40 Gew.-%  $\text{YPO}_4$ :Ce und 30 bis 70 Gew.-%  $\text{BaSi}_2\text{O}_5$ :Pb umfasst,
- 30 wobei die Summe der prozentualen Gewichtsanteile der Leuchtstoffe in der Mischung 100% ergibt, und das Leuchtstoffgemisch zusätzlich eine optionale Menge an  $\text{SrCe}_{0,08}\text{MgAl}_{11}\text{O}_{18}$  in einem Bereich von 0 bis 12 Gew.-% der Mischung enthält.
- 35 2. Leuchtstoffgemisch nach Anspruch 1, wobei die Mischung aus UVA-emittierenden Leuchtstoffen 30 bis 40 Gew.-%  $\text{SrB}_4\text{O}_7$ :Eu, 30 bis 40 Gew.-%  $\text{YPO}_4$ :Ce und 30 bis 40 Gew.-%  $\text{BaSi}_2\text{O}_5$ :Pb umfasst.
- 40 3. Leuchtstoffgemisch nach Anspruch 1, wobei die Mischung aus UVA-emittierenden Leuchtstoffen 30 bis 35 Gew.-%  $\text{SrB}_4\text{O}_7$ :Eu, 30 bis 35 Gew.-%  $\text{YPO}_4$ :Ce und 30 bis 35 Gew.-%  $\text{BaSi}_2$ :Pb umfasst.
4. Leuchtstoffgemisch nach Anspruch 1, wobei die Mischung aus UVA-emittierenden Leuchtstoffen ungefähr 33,3 Gew.-%  $\text{SrB}_4\text{O}_7$ :Eu, ungefähr 33,3 Gew.-%  $\text{YPO}_4$ :Ce und ungefähr 33,3 Gew.-%  $\text{BaSi}_2\text{O}_5$ :Pb umfasst.
- 45 5. Leuchtstoffgemisch nach Anspruch 1, wobei die Mischung aus UVA-emittierenden Leuchtstoffen 0 bis 20 Gew.-%  $\text{SrB}_4\text{O}_7$ :Eu, 0 bis 20 Gew.-%  $\text{YPO}_4$ :Ce und 50 bis 70 Gew.-%  $\text{BaSi}_2\text{O}_5$ :Pb umfasst.
6. Leuchtstoffgemisch nach Anspruch 1, wobei die Mischung aus UVA-emittierenden Leuchtstoffen 15 bis 20 Gew.-%  $\text{SrB}_4\text{O}_7$ :Eu, 15 bis 20 Gew.-%  $\text{YPO}_4$ :Ce und 65 bis 70 Gew.-%  $\text{BaSi}_2\text{O}_5$ :Pb umfasst.
- 50 7. Leuchtstoffgemisch nach Anspruch 1, wobei die Mischung aus UVA-emittierenden Leuchtstoffen ungefähr 16,7 Gew.-%  $\text{SrB}_4\text{O}_7$ :Eu, ungefähr 16,7 Gew.-%  $\text{YPO}_4$ :Ce und ungefähr 66,6 Gew.-%  $\text{BaSi}_2\text{O}_5$ :Pb umfasst.
8. Leuchtstoffgemisch nach Anspruch 1, wobei die Mischung aus UVA-emittierenden Leuchtstoffen ungefähr 50 Gew.-%  $\text{SrB}_4\text{O}_7$ :Eu und ungefähr 50 Gew.-%  $\text{BaSi}_2\text{O}_5$ :Pb umfasst.
- 55 9. Bräunungs-Leuchtstofflampe, die hat:
- eine UV-durchlässige Umhüllung (3); und  
eine Leuchtstoffbeschichtung (7) an einer Innenwand der Umhüllung (3),

## EP 1 441 383 B1

wobei die Leuchtstoffbeschichtung (7) ein UV-emittierendes Leuchtstoffgemisch enthält, das umfasst:

eine Mischung aus wenigstens zwei UVA-emittierenden Leuchtstoffen, die aus  $\text{SrB}_4\text{O}_7:\text{Eu}$ ,  $\text{YPO}_4:\text{Ce}$  und  $\text{BaSi}_2\text{O}_5:\text{Pb}$  ausgewählt werden,

wobei das Leuchtstoffgemisch zusätzlich eine optionale Menge an  $\text{SrCe}_{0,08}\text{MgAl}_{11}\text{O}_{18}$  in einem Bereich zwischen 0 bis 12 Gew.-% der Mischung enthält,

wobei die Lampe eine 100-h-UVA-Lebensdauer von wenigstens 87 % aufweist.

10. Leuchtstofflampe nach Anspruch 9, wobei die Lampe eine 0-h-UVA-Ausgabe von wenigstens  $8800 \mu\text{W}/\text{cm}^2$  aufweist.

11. Leuchtstofflampe nach Anspruch 9, wobei die Mischung aus UVA-emittierenden Leuchtstoffen 40 bis 60 Gew.-%  $\text{SrB}_4\text{O}_7:\text{Eu}$  und 40 bis 60 Gew.-%  $\text{YPO}_4:\text{Ce}$  umfasst.

12. Leuchtstofflampe nach Anspruch 10, wobei die Mischung aus UVA-emittierenden Leuchtstoffen 0 bis 50 Gew.-%  $\text{SrB}_4\text{O}_7:\text{Eu}$ , 0 bis 40 Gew.-%  $\text{YPO}_4:\text{Ce}$  und 30 bis 70 Gew.-%  $\text{BaSi}_2\text{O}_5:\text{Pb}$  umfasst.

13. Leuchtstofflampe nach Anspruch 10, wobei die Mischung aus UVA-emittierenden Leuchtstoffen 0 bis 20 Gew.-%  $\text{SrB}_4\text{O}_7:\text{Eu}$ , 0 bis 20 Gew.-%  $\text{YPO}_4:\text{Ce}$  und 50 bis 70 Gew.-%  $\text{BaSi}_2\text{O}_5:\text{Pb}$  umfasst.

14. Leuchtstofflampe nach Anspruch 10, wobei die Mischung aus UVA-emittierenden Leuchtstoffen 40 bis 60 Gew.-%  $\text{SrB}_4\text{O}_7:\text{Eu}$  und 40 bis 60 Gew.-%  $\text{BaSi}_2\text{O}_5:\text{Pb}$  umfasst.

15. Leuchtstofflampe nach Anspruch 10, wobei die Umhüllung (3) röhrenförmig ist und des Weiteren eine Reflektorschicht (5) enthält, die sich über ein  $220^\circ$ -Segment des Umfangs der Umhüllung (3) erstreckt, die Reflektorschicht (5) zwischen der Umhüllung (3) und der Leuchtstoffschicht (7) angeordnet ist, die Leuchtstoffschicht (7) sich über den gesamten Umfang der Umhüllung (3) erstreckt.

### Revendications

1. Combinaison de substances phosphorescentes émettant des UV comprenant :

un mélange de substances phosphorescentes émettant des UVA comprenant 0 à 50 % en poids de  $\text{SrB}_4\text{O}_7:\text{Eu}$ , 0 à 40 % en poids de  $\text{YPO}_4:\text{Ce}$ , et 30 à 70 % en poids de  $\text{BaSi}_2\text{O}_5:\text{Pb}$ ,

dans lequel la somme des pourcentages en poids des substances phosphorescentes dans le mélange est égale à 100 % ; et

la combinaison de substances phosphorescentes contient de plus une quantité facultative de  $\text{SrCe}_{0,08}\text{MgAl}_{11}\text{O}_{18}$  à raison de 0 à 12 % en poids du mélange.

2. Combinaison de substances phosphorescentes selon la revendication 1, dans laquelle le mélange de substances phosphorescentes émettant des UVA comprend 30 à 40 % en poids de  $\text{SrB}_4\text{O}_7:\text{Eu}$ , 30 à 40 % en poids de  $\text{YPO}_4:\text{Ce}$ , et 30 à 40 % en poids de  $\text{BaSi}_2\text{O}_5:\text{Pb}$ .

3. Combinaison de substances phosphorescentes selon la revendication 1, dans laquelle le mélange de substances phosphorescentes émettant des UVA comprend 30 à 35 % en poids de  $\text{SrB}_4\text{O}_7:\text{Eu}$ , 30 à 35 % en poids de  $\text{YPO}_4:\text{Ce}$ , et 30 à 35 % en poids de  $\text{BaSi}_2\text{O}_5:\text{Pb}$ .

4. Combinaison de substances phosphorescentes selon la revendication 1, dans laquelle le mélange de substances phosphorescentes émettant des UVA comprend environ 33,3 % en poids de  $\text{SrB}_4\text{O}_7:\text{Eu}$ , environ 33,3 % en poids de  $\text{YPO}_4:\text{Ce}$ , et environ 33,3 % en poids de  $\text{BaSi}_2\text{O}_5:\text{Pb}$ .

5. Combinaison de substances phosphorescentes selon la revendication 1, dans laquelle le mélange de substances phosphorescentes émettant des UVA comprend 0 à 20 % en poids de  $\text{SrB}_4\text{O}_7:\text{Eu}$ , 0 à 20 % en poids de  $\text{YPO}_4:\text{Ce}$ , et 50 à 70 % en poids de  $\text{BaSi}_2\text{O}_5:\text{Pb}$ .

6. Combinaison de substances phosphorescentes selon la revendication 1, dans laquelle le mélange de substances

## EP 1 441 383 B1

phosphorescentes émettant des UVA comprend 15 à 20 % en poids de  $\text{SrB}_4\text{O}_7\text{:Eu}$ , 15 à 20 % en poids de  $\text{YPO}_4\text{:Ce}$ , et 65 à 70 % en poids de  $\text{BaSi}_2\text{O}_5\text{:Pb}$ .

- 5 7. Combinaison de substances phosphorescentes selon la revendication 1, dans laquelle le mélange de substances phosphorescentes émettant des UVA comprend environ 16,7 % en poids de  $\text{SrB}_4\text{O}_7\text{:Eu}$ , environ 16,7 % en poids de  $\text{YPO}_4\text{:Ce}$ , et environ 66,6 % en poids de  $\text{BaSi}_2\text{O}_5\text{:Pb}$ .
- 10 8. Combinaison de substances phosphorescentes selon la revendication 1, dans laquelle le mélange de substances phosphorescentes émettant des UVA comprend environ 50 % en poids de  $\text{SrB}_4\text{O}_7\text{:Eu}$  et environ 50 % en poids de  $\text{BaSi}_2\text{O}_5\text{:Pb}$ .
- 15 9. Lampe bronzante fluorescente ayant :
- une enveloppe transparente aux UV (3) ; et  
un revêtement de substance phosphorescente (7) sur une paroi intérieure de l'enveloppe (3),  
le revêtement de substance phosphorescente (7) contenant une combinaison de substances phosphorescentes comprenant :
- 20 un mélange d'au moins deux substances phosphorescentes émettant des UVA choisies parmi  $\text{SrB}_4\text{O}_7\text{:Eu}$ ,  $\text{YPO}_4\text{:Ce}$ , et  $\text{BaSi}_2\text{O}_5\text{:Pb}$ ,  
la combinaison de substances phosphorescentes contenant de plus une quantité facultative de  $\text{SrCe}_{0,08}\text{MgAl}_{11}\text{O}_{18}$  à raison de 0 à 12 % en poids du mélange,
- 25 laquelle lampe présente un maintien des UVA sur 100 heures d'au moins 87 %.
- 30 10. Lampe fluorescente selon la revendication 9, laquelle lampe délivre au moins  $8800 \mu\text{W}/\text{cm}^2$  d'UVA à 0 heure.
11. Lampe fluorescente selon la revendication 9, dans laquelle le mélange de substances phosphorescentes émettant des UVA comprend 40 à 60 % en poids de  $\text{SrB}_4\text{O}_7\text{:Eu}$  et 40 à 60 % en poids de  $\text{YPO}_4\text{:Ce}$ .
- 35 12. Lampe fluorescente selon la revendication 10, dans laquelle le mélange de substances phosphorescentes émettant des UVA comprend 0 à 50 % en poids de  $\text{SrB}_4\text{O}_7\text{:Eu}$ , 0 à 40 % en poids de  $\text{YPO}_4\text{:Ce}$ , et 30 à 70 % en poids de  $\text{BaSi}_2\text{O}_5\text{:Pb}$ .
13. Lampe fluorescente selon la revendication 10, dans laquelle le mélange de substances phosphorescentes émettant des UVA comprend 0 à 20 % en poids de  $\text{SrB}_4\text{O}_7\text{:Eu}$ , 0 à 20 % en poids de  $\text{YPO}_4\text{:Ce}$ , et 50 à 70 % en poids de  $\text{BaSi}_2\text{O}_5\text{:Pb}$ .
- 40 14. Lampe fluorescente selon la revendication 10, dans laquelle le mélange de substances phosphorescentes émettant des UVA comprend 40 à 60 % en poids de  $\text{SrB}_4\text{O}_7\text{:Eu}$  et 40 à 60 % en poids de  $\text{BaSi}_2\text{O}_5\text{:Pb}$ .
- 45 15. Lampe fluorescente selon la revendication 10, dans laquelle l'enveloppe (3) est tubulaire et contient en outre une couche réfléchissante (5) s'étendant sur un segment de  $220^\circ$  de la circonférence de l'enveloppe (3), la couche réfléchissante (5) étant disposée entre l'enveloppe (3) et la couche de substance phosphorescente (7), la couche de substance fluorescente (7) s'étendant sur toute la circonférence de l'enveloppe (3).
- 50
- 55

**Fig. 1**  
**(Prior Art)**

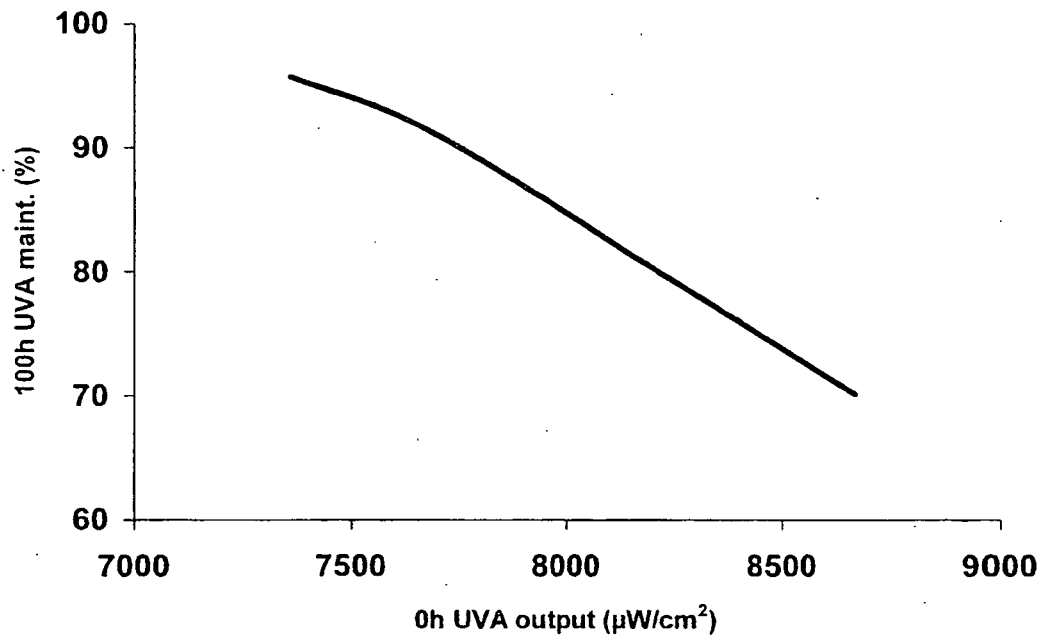

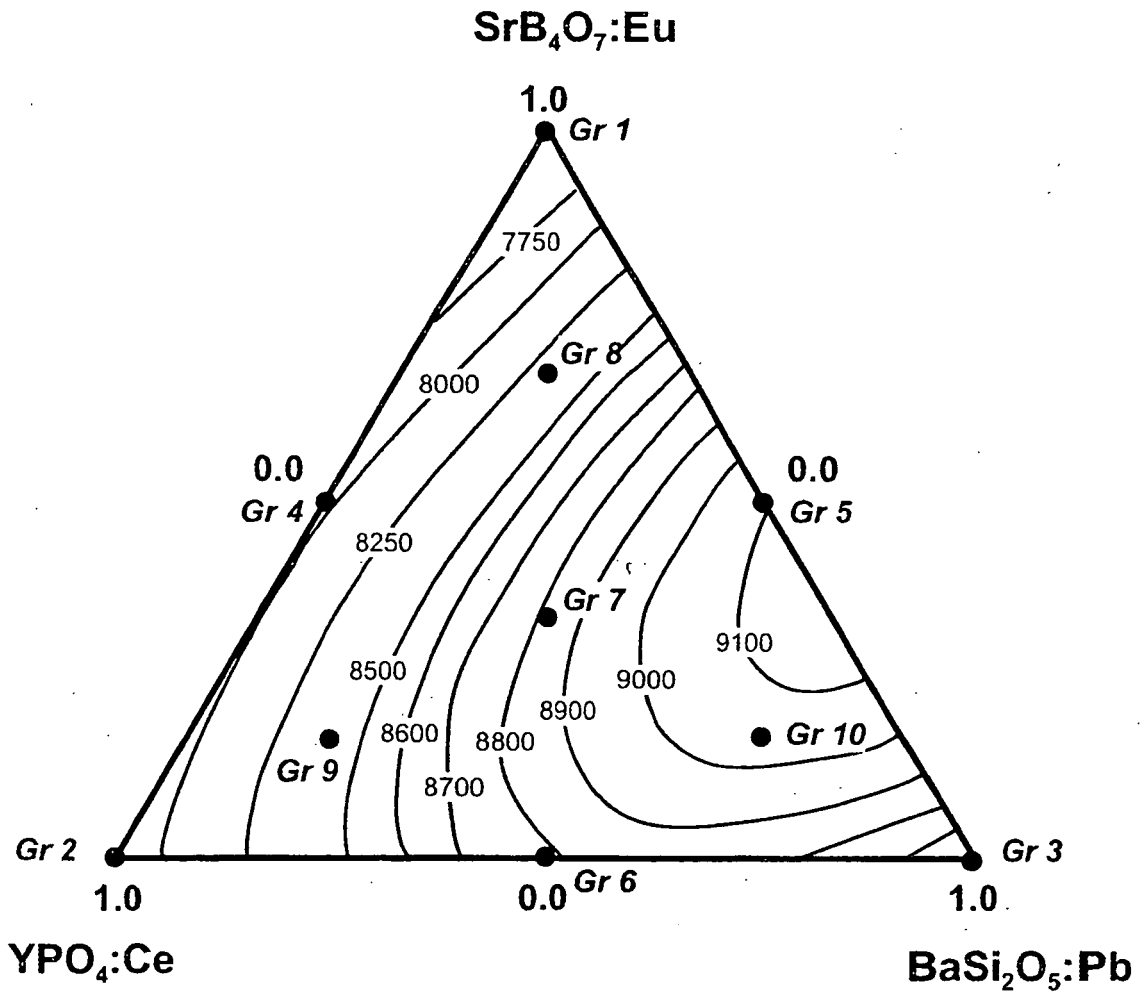

FIG. 2

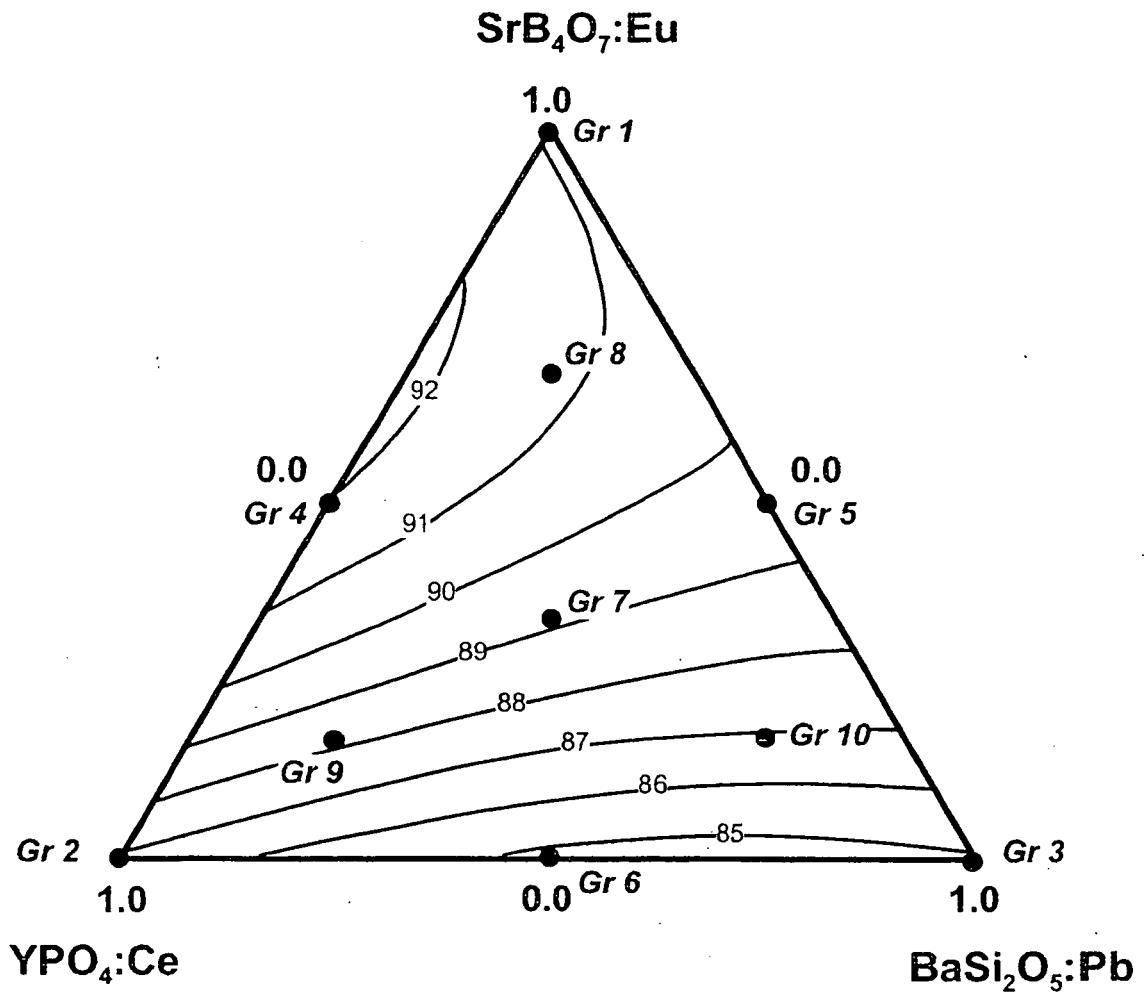

FIG. 3

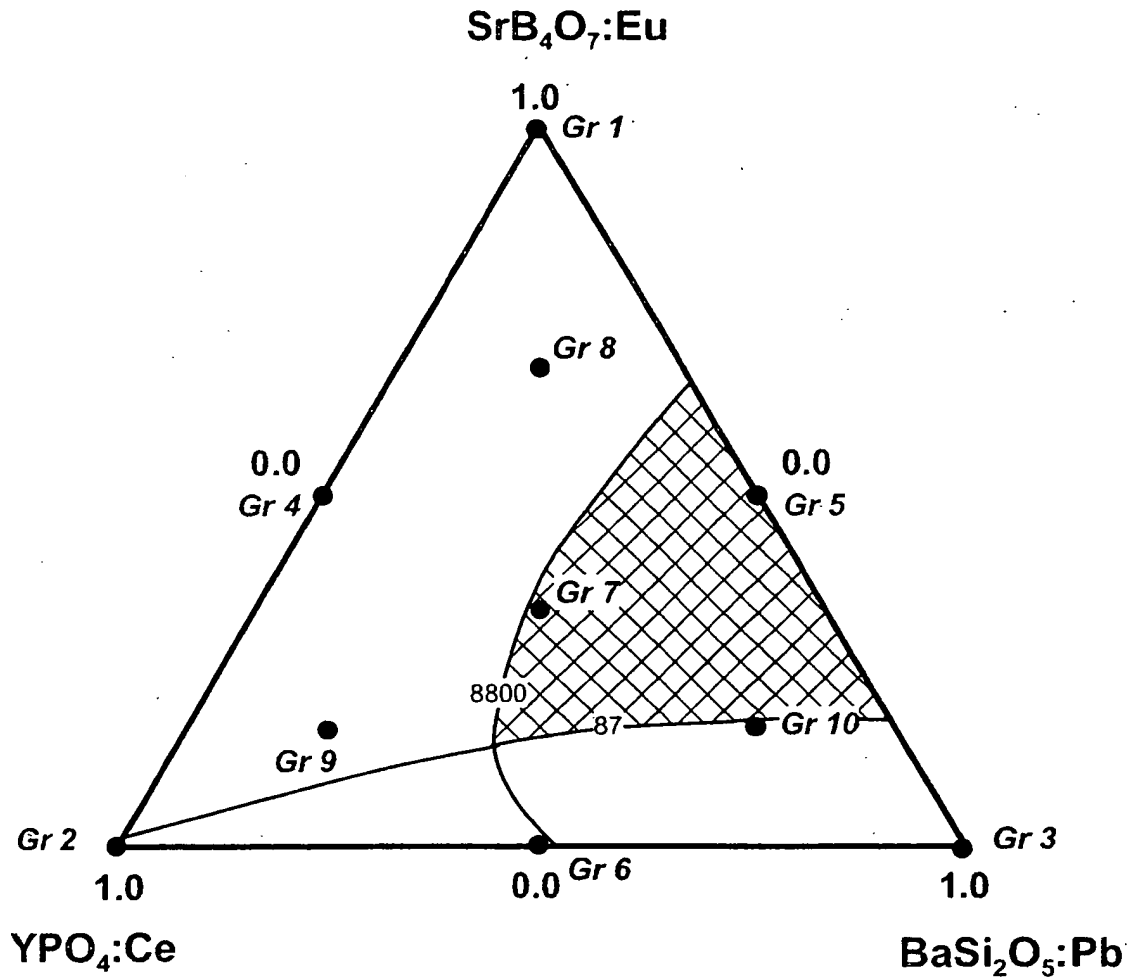
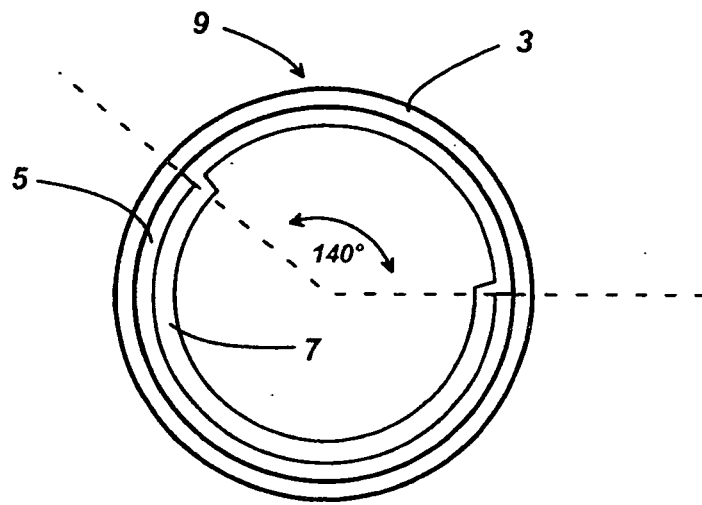

FIG. 4



**FIG. 5**

**REFERENCES CITED IN THE DESCRIPTION**

*This list of references cited by the applicant is for the reader's convenience only. It does not form part of the European patent document. Even though great care has been taken in compiling the references, errors or omissions cannot be excluded and the EPO disclaims all liability in this regard.*

**Patent documents cited in the description**

- US 4585673 A [0003]
- US 4710674 A [0003]
- US 4825124 A [0003]
- US 5523018 A [0003]
- US 4859903 A [0006]