



(11) **EP 3 144 282 A1**

(12) **EUROPEAN PATENT APPLICATION**

(43) Date of publication:
22.03.2017 Bulletin 2017/12

(51) Int Cl.:
C03B 5/235 (2006.01)

(21) Application number: **16188859.9**

(22) Date of filing: **14.09.2016**

(84) Designated Contracting States:
AL AT BE BG CH CY CZ DE DK EE ES FI FR GB GR HR HU IE IS IT LI LT LU LV MC MK MT NL NO PL PT RO RS SE SI SK SM TR
Designated Extension States:
BA ME
Designated Validation States:
MA MD

(72) Inventors:
• **Huber, Aaron Morgan**
Castle Rock, CO 80108 (US)
• **Faulkinbury, Albert Patrick**
Highlands Ranch, CO 80126 (US)

(74) Representative: **Patentanwälte Olbricht Buchhold Keulertz**
Partnerschaft mbB
Bettinastraße 53-55
60325 Frankfurt am Main (DE)

(30) Priority: **15.09.2015 US 201514854271**

(71) Applicant: **Johns Manville**
Denver, CO 80202 (US)

(54) **METHODS OF MELTING FEEDSTOCK USING A SUBMERGED COMBUSTION MELTER**

(57) Methods (600, 700, 800, 900) of maximizing mixing and melting in a submerged combustion melter (SCM) are described. One method (600, 700) includes melting an inorganic feedstock in an SCM using an arrangement of two or more submerged combustion (SC) burners (R1N, R1C, R1S, R2N, R2C, R2S, R3N, R3C, R3S), the SCM having a length (L) and a width (W), a centerline (C), a north side (N) and a south side (S), and operating the arrangement of SC burners (R1N, R1C, R1S, R2N, R2C, R2S, R3N, R3C, R3S) such that a progressively higher percentage of a total combustion flow

from the SC burners (R1N, R1C, R1S, R2N, R2C, R2S, R3N, R3C, R3S) occurs from SC burners (R1 N, R1C, R1S, R2N, R2C, R2S, R3N, R3C, R3S) at progressively downstream positions in the SCM. Other methods (600, 700) include operating the north sided (N) and south sided (S) SC burners (R1N, R1 S, R2N, R2S, R3N, R3S) with more combustion flow than the central burners (R1C, R2C, R3C). Other methods (800) include strategic placement of fuel lean SC burners (R1N, R1C, R1S, R2N, R2C, R2S, R3N, R3C, R3S) and fuel rich SC burners (R1N, R1C, R1S, R2N, R2C, R2S, R3N, R3C, R3S).

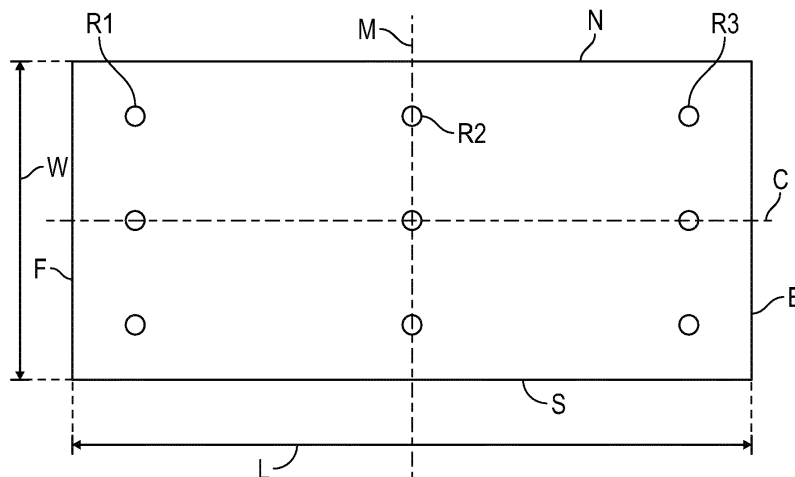

FIG. 11

EP 3 144 282 A1

Description

BACKGROUND INFORMATION

5 **[0001]** This application claims priority of U.S. Patent Application No. 14/854,271, filed on September 15, 2015, the entire disclosure of which is hereby incorporated herein by reference.

Technical Field

10 **[0002]** The present disclosure relates generally to the field of submerged combustion melters and apparatus, and methods of use, and more specifically to submerged combustion melters, and methods of operating same, particularly for melting glass-forming materials, mineral wool forming materials, and other non-metallic inorganic materials.

Background Art

15 **[0003]** A submerged combustion melter (SCM) may be employed to melt glass batch and/or waste glass materials to produce molten glass, or may melt mineral wool feedstock (basalt rock, sometimes referred to as lava rock) to make mineral or rock wool, by passing oxygen, oxygen-enriched mixtures, or air along with a liquid, gaseous and/or particulate fuel (some of which may be in one or more of the feedstock materials), directly into a molten pool of glass or other material, usually through burners submerged in a turbulent melt pool. The introduction of high flow rates of products of combustion of the oxidant and fuel into the molten material, and the expansion of the gases during submerged combustion (SC), cause rapid melting of the feedstock and much turbulence and foaming. Conventional melters operate primarily by combusting fuel and oxidant above the molten pool of melt, and are very laminar in flow characteristics compared to SCMs.

20 **[0004]** Residence time of the material being melted in the SCM is critical to achieving good quality product. Channeling (feedstock exiting the SCM before being well mixed or melted) is problematic as it is wasteful and decreases melt quality. It would be advantageous to maximize mixing and/or heating (increase temperature) in SCMs in order to improve the quality (mainly determined by homogeneity) of the melt from an SCM.

30 SUMMARY

[0005] In accordance with the present disclosure, methods of maximize mixing and/or heating (increase temperature) in SCMs using "SC burner profiling" in order to improve the quality (mainly determined by homogeneity) of the melt from an SCM, and/or or reduce feedstock loss through SCM exhaust, are described that may reduce or eliminate problems with known SCM operation to produce molten glass and other non-metallic inorganic materials, such as rock wool and mineral wool.

[0006] One aspect of this disclosure is a method of maximizing mixing and melting in an SCM, the method comprising (or consisting essentially of, or consisting of):

- 40 (a) melting an inorganic feedstock in an SCM using an arrangement of two or more SC burners, the SCM having a length (L) and a width (W), a centerline (C), a north side (N) and a south side (S); and
(b) operating the arrangement of SC burners such that a progressively higher percentage of a total combustion flow from the SC burners occurs from SC burners at progressively downstream positions.

45 **[0007]** Another method of the disclosure is a method maximizing mixing and melting in an SCM, the method comprising (or consisting essentially of, or consisting of):

- (a) melting an inorganic feedstock in an SCM using an arrangement of two or more SC burners, the SCM having a length and a width, a centerline, a north side and a south side; and
50 (b) operating the arrangement of SC burners such that a progressively lower percentage of total combustion flow rate from the SC burners occurs from SC burners at progressively downstream positions from the feed end of the SCM up to a midpoint of the SCM length, and such that a progressively higher percentage of total combustion flow rate from the SC burners occurs from SC burners at progressively downstream positions from the midpoint to the melt exit end of the SCM.

55 **[0008]** Other method and apparatus embodiments, such as detailed herein, are considered aspects of this disclosure. Systems, apparatus, and methods of the disclosure will become more apparent upon review of the brief description of the drawings, the detailed description of the disclosure, and the claims that follow.

BRIEF DESCRIPTION OF THE DRAWINGS

[0009] The manner in which the objectives of the disclosure and other desirable characteristics can be obtained is explained in the following description and attached drawings in which:

FIG. 1 is a schematic side elevation view, partially in cross-section, of a prior art submerged combustion melter and method, and FIG. 2 is a bar graph illustrating a prior method of operating submerged combustion burners;

FIG. 3 is a line graph comparing tracer concentration for two prior art methods of operating the SCM of FIGS. 1 and 11 with a method of the present disclosure;

FIG. 4 is a bar graph illustrating three methods of operating submerged combustion burners in the SCM of FIG. 1 in accordance with the present disclosure;

FIGS. 5 and 6 are schematic side elevation view, partially in cross-section, of a submerged combustion melter and two alternate methods of operating same in accordance with the present disclosure;

FIGS. 7, 8, 9, and 10 are logic diagrams illustrating various methods of the present disclosure; and

FIG. 11 is a schematic plan view of one melter floor plan in accordance with the present disclosure.

[0010] It is to be noted, however, that the appended drawings are schematic in nature, may not be to scale, and illustrate only typical embodiments of this disclosure and are therefore not to be considered limiting of its scope, for the disclosure may admit to other equally effective embodiments.

DETAILED DESCRIPTION

[0011] In the following description, numerous details are set forth to provide an understanding of the disclosed systems, apparatus, and methods. However, it will be understood by those skilled in the art that the systems, apparatus, and methods covered by the claims may be practiced without these details and that numerous variations or modifications from the specifically described embodiments may be possible and are deemed within the claims. For example, wherever the term "comprising" is used, embodiments and/or components where "consisting essentially of" and "consisting of" are explicitly disclosed herein and are part of this disclosure. All U.S. published patent applications and U.S. Patents referenced herein are hereby explicitly incorporated herein by reference. In the event definitions of terms in the referenced patents and applications conflict with how those terms are defined in the present application, the definitions for those terms that are provided in the present application shall be deemed controlling. All percentages herein are based on weight unless otherwise specified.

[0012] As explained briefly in the Background, one drawback to present operation of SCMs is that channeling (feedstock exiting the SCM before being well mixed or melted) is problematic as it is wasteful and decreases melt quality. It would therefore be extremely advantageous to maximize mixing and/or heating (increase temperature) in SCMs in order to improve the quality (mainly determined by homogeneity) of the melt from an SCM. Inventors herein have discovered various "burner profiles" that achieve the desired goal of increased residence time of the material being melted in the SCM, which is critical to achieving good quality product.

[0013] There are innumerable options, variations within options, and sub-variations of options for the SCM operator to select from when operating an SCM and profiling the SC burners. After all, the SCM is essentially a continuous or semi-batch chemical reactor with simultaneous heat and mass transfer. For example, to name just a few, an operator may choose (option 1) to operate all SC burners equally, that is, using the same fuel and oxidant, and of the total combustion flow rate (TCFR) from the SC burners, each SC burner is operated to produce the same fraction of the TCFR. Another option (option 2) would be to operate as option 1, but with different oxidant in one or more burners. Option 3 may be to operate with same oxidant in all burners, but with different fuel in one or more SC burners. As one can readily see, the number of options is quite large, and selecting the operation of the SC burners in such a chemical reactor with simultaneous heat and mass transfer can be an overwhelming task. Even if the "same" fuel and "same" oxidant are used for each SC burner (an ideal assumption that is never true in practice, since fuel and oxidant compositions change with time), the variations are endless, and can be an overwhelming task to sort through.

[0014] The present disclosure is devoted to resolving this challenge by "burner profiling", in other words, closely adjusting each burner's combustion flow rate so that residence time of feedstock is maximized the melter, and/or increasing mixing and/or temperature, or increasing mixing of melt in the melter without an increase in temperature.

[0015] Various terms are used throughout this disclosure. The terms "process" and "method" are considered

interchangeable. "Submerged" as used herein means that combustion gases emanate from combustion burners or combustion burner panels under the level of the molten glass; the burners or burner panels may be floor-mounted, wall-mounted, or in melter embodiments comprising more than one submerged combustion burner, any combination thereof (for example, two floor mounted burner panels and one wall mounted burner panel). Burner panels (such as described in assignee's co-pending U.S. Patent Application Serial No. 14/838,148, filed August 27, 2015) may form part of an SCM floor and/or wall structure. In certain embodiments one or more burner panels described herein may form the entire floor. A "burner panel" is simply a panel equipped to emit fuel and oxidant, or in some embodiments only one of these (for example a burner panel may only emit fuel, while another burner panel emits only oxidant, and vice versa). "SC" as used herein means "submerged combustion" unless otherwise specifically noted, and "SCM" means submerged combustion melter unless otherwise specifically noted.

[0016] As used herein the phrase "combustion gases" as used herein means substantially gaseous mixtures comprised primarily of combustion products, such as oxides of carbon (such as carbon monoxide, carbon dioxide), oxides of nitrogen, oxides of sulfur, and water, as well as partially combusted fuel, non-combusted fuel, and any excess oxidant. Combustion products may include liquids and solids, for example soot and unburned liquid fuels. "Exhaust", "melter exhaust", and "melter flue gas" are equivalent terms and refer to a combination of combustion gases and effluent from the feedstock being melted, such as adsorbed water, water of hydration, CO₂ liberated from CaCO₃, and the like. Therefore exhaust may comprise oxygen or other oxidants, nitrogen, combustion products (including but not limited to, carbon dioxide, carbon monoxide, NO_x, SO_x, H₂S, and water), uncombusted fuel, reaction products of melt-forming ingredients (for example, but not limited to, basalt, sand (primarily SiO₂), clay, limestone (primarily CaCO₃), burnt dolomitic lime, borax and boric acid, and the like.

[0017] As used herein, unless indicated to the contrary, "feedstock" includes, but is not limited to: glass batch; cullet; and pieces of porous, semi-porous, or solid rock or other non-metallic inorganic material having a weight average particle size ranging from about 1 mm to about 10 cm, or from about 1 cm to about 10 cm, or from about 2 to about 5 cm, or from about 1 to about 2 cm. The only upper limit on feedstock weight average particle size is the internal diameter of feedstock supply structure components, such as described in assignee's co-pending U.S. Patent Application Serial No. 14/844,198, filed September 3, 2015, while the lower size limit is determined by angle of flow, flow rate of feedstock, and in those embodiments where heat is exchanged directly or indirectly from melter exhaust to the feedstock, flow rate of melter exhaust.

[0018] "Oxidant" as used herein includes air, gases having the same molar concentration of oxygen as air (for example "synthetic air"), oxygen-enriched air (air having oxygen concentration greater than 21 mole percent), and "pure" oxygen grades, such as industrial grade oxygen, food grade oxygen, and cryogenic oxygen. Oxygen-enriched air may have 50 mole percent or more oxygen, and in certain embodiments may be 90 mole percent or more oxygen.

[0019] The term "fuel", according to this disclosure, means a combustible composition comprising a major portion of, for example, methane, natural gas, liquefied natural gas, propane, hydrogen, steam-reformed natural gas, atomized hydrocarbon oil, combustible powders and other flowable solids (for example coal powders, carbon black, soot, and the like), and the like. Fuels useful in the disclosure may comprise minor amounts of non-fuels therein, including oxidants, for purposes such as premixing the fuel with the oxidant, or atomizing liquid or particulate fuels. As used herein the term "fuel" includes gaseous fuels, liquid fuels, flowable solids, such as powdered carbon or particulate material, waste materials, slurries, and mixtures or other combinations thereof. Certain methods within the disclosure include methods wherein the fuel may be a substantially gaseous fuel selected from the group consisting of methane, natural gas, liquefied natural gas, propane, carbon monoxide, hydrogen, steam-reformed natural gas, atomized oil or mixtures thereof, and the oxidant may be an oxygen stream comprising at least 90 mole percent oxygen.

[0020] The sources of oxidant and fuel may be one or more conduits, pipelines, storage facilities, cylinders, or, in embodiments where the oxidant is air, ambient air. Oxygen-enriched oxidants may be supplied from a pipeline, cylinder, storage facility, cryogenic air separation unit, membrane permeation separator, or adsorption unit such as a vacuum swing adsorption unit.

[0021] Certain method embodiments may comprise a method maximizing mixing and melting in an SCM, the method comprising (or consisting essentially of, or consisting of):

- (a) melting an inorganic feedstock in an SCM using an arrangement of two or more SC burners, the SCM having a length L and a width W, a centerline C, a north side N and a south side S; and
- (b) operating the arrangement of SC burners such that a progressively higher percentage of a total combustion flow from the SC burners occurs from SC burners at progressively downstream positions.

[0022] Certain method embodiments may include wherein the melting using an arrangement of two or more SC burners comprises melting with a matrix of at least two rows and at least two columns of SC burners wherein a row spans a majority of the width W and a column spans a majority of the length L of the SCM, and wherein the operating is selected from the group consisting of:

EP 3 144 282 A1

(c) each SC burner in a first row R1 operates at a rate r_1 , each SC burner in a second row R2 operates at a rate r_2 , wherein $r_2 > r_1$, and

(d) if the matrix is a two row by three column matrix or larger, SC burners on the N and S sides in the first row R1 operate at a rate r_3 , the SC burner in the center C of the first row R1 operates at a rate r_4 , where $r_3 > r_4$, and SC burners on N and S sides in a second row R2 operate at a rate r_5 and the SC burner in the center C operates at a rate r_6 , where $r_5 > r_6 \geq r_4$, and $r_5 > r_3$.

[0023] Certain method embodiments may include wherein the melting using an arrangement of two or more SC burners comprises melting with a matrix of at least two rows and at least two columns of SC burners wherein a row spans a majority of the width W and a column spans a majority of the length L of the SCM, and wherein the operating comprises

(c) each SC burner in a first row R1 operates at a rate r_1 , each SC burner in a second row R2 operates at a rate r_2 , wherein $r_2 > r_1$.

[0024] Certain method embodiments may include wherein the melting using an arrangement of two or more SC burners comprises melting with a matrix of at least two rows and at least two columns of SC burners wherein a row spans a majority of the width W and a column spans a majority of the length L of the SCM, and wherein the operating comprises

(d) if the matrix is a two row by three column matrix or larger, SC burners on the N and S sides in the first row R1 operate at a rate r_3 , and SC burners in the center C of the first row operate at a rate r_4 , where $r_3 > r_4$, and SC burners on N and S sides in a second row R2 operate at a rate r_5 and SC burners in the center C operate at a rate r_6 , where $r_5 > r_6 \geq r_4$, and $r_5 > r_3$.

[0025] Certain method embodiments may further comprise measuring concentration of a tracer compound or element in melt exiting the SCM to verify an increase in residence time of melt in the SCM compared to residence time of the melt when all SC burners are firing equally. In certain methods, the tracer compound or element may be selected from the group consisting of ZnO (zinc oxide), SrCO₃ (strontium carbonate), BaCO₃ (barium carbonate), and Li₂CO₃ (lithium carbonate), and mixtures and combinations thereof.

[0026] According a special method design, the progressively higher percentage of total combustion flow rate from the SC burners occurs from SC burners at progressively downstream positions from the midpoint to the melt exit end of the SCM, and

(b) operating the arrangement of SC burners such that a progressively lower percentage of total combustion flow rate from the SC burners occurs from SC burners at progressively downstream positions from the feed end of the SCM up to a midpoint of the SCM length.

[0027] Certain method embodiments may include maximizing mixing and melting in an SCM, the method comprising (or consisting essentially of, or consisting of):

(a) melting an inorganic feedstock in an SCM using an arrangement of two or more SC burners, the SCM having a length L and a width W, a centerline C, a north side N and a south side S; and

(b) operating the arrangement of SC burners such that a progressively lower percentage of total combustion flow rate from the SC burners occurs from SC burners at progressively downstream positions from the feed end of the SCM up to a midpoint M of the SCM length L, and such that a progressively higher percentage of total combustion flow rate from the SC burners occurs from SC burners at progressively downstream positions from the midpoint M to the melt exit end of the SCM.

[0028] Certain method embodiments may include wherein the melting using an arrangement of two or more SC burners comprises melting with a matrix of at least two rows and at least two columns of SC burners wherein a row spans a majority of the width W and a column spans a majority of the length L of the SCM, and wherein the operating the arrangement of SC burners comprises operating the SC burners such that SC burners nearer the feed end of the SCM have a flow rate r_7 , SC burners near the melt exit end have a flow rate r_8 , and SC burners near an intersection of L and M have a flow rate r_9 , wherein:

$$r_7 > r_9$$

$$r_8 > r_9,$$

and

$$r_8 \geq r_7.$$

[0029] Certain method embodiments may include wherein the matrix is a 3 row x 3 column matrix, and SC burners on the N and S sides have flow rate greater than the center SC burners.

[0030] In certain embodiments the method further comprises measuring concentration of a tracer compound or element in melt exiting the SCM to verify an increase in residence time of melt in the SCM compared to residence time of the melt when all SC burners are firing equally.

[0031] In certain embodiments the tracer compound or element is selected from the group consisting of ZnO (zinc oxide), SrCO₃ (strontium carbonate), BaCO₃ (barium carbonate), and Li₂CO₃ (lithium carbonate), and mixtures and combinations thereof.

[0032] Certain method embodiments may include maximizing mixing and temperature increase in an SCM, the method comprising (or consisting essentially of, or consisting of):

(a) melting an inorganic feedstock in an SCM using an arrangement of two or more SC burners, the SCM having a length L and a width W, a centerline C, a north side N and a south side S; and

(b) operating the arrangement of SC burners such that SC burners in a first zone of the SCM operate fuel lean, and SC burners in a second zone of the SCM operate fuel rich, and where combustion products of the SC burners in the first zone mix with combustion products of the SC burners of the second zone at a position in the SCM higher than where the lean or rich combustion takes place.

[0033] Certain method embodiments may include wherein the melting using an arrangement of two or more SC burners comprises melting with a matrix of at least two rows and at least two columns of SC burners wherein a row spans a majority of the width W and a column spans a majority of the length L of the SCM.

[0034] Certain method embodiments may include wherein the matrix is a 3 row by 3 column matrix and the first zone is at a midpoint M of the SCM length L, and the second zone is downstream of the midpoint M of the SCM length L.

[0035] Certain method embodiments may include wherein the matrix is a 3 row by 3 column matrix and the first zone is at a midpoint M of the SCM length L, and the second zone is upstream of the midpoint M of the SCM length L.

[0036] Certain method embodiments may include wherein the first (lean) zone is near the feed inlet, and the second (fuel rich) zone is immediately downstream the first zone, and including feeding small (less than 1 mm APS) particle size batch material to the SCM in the feed inlet.

[0037] Certain method embodiments may include maximizing mixing without substantially increasing temperature in an SCM, the method comprising (or consisting essentially of, or consisting of):

(a) melting an inorganic feedstock in an SCM using an arrangement of two or more SC burners, the SCM having a length L and a width W, a centerline C, a north side N and a south side S; and

(b) operating the arrangement of SC burners such that SC burners in a first zone of the SCM operate fuel lean, and SC burners in all other zones of the SCM operate neither fuel rich nor fuel lean.

[0038] Certain method embodiments may include wherein the lean zone is between the feed end of the SCM and the midpoint M. Certain method embodiments may include wherein the lean zone is nearer the melter feed end than any other melting zone. Certain method embodiments may include wherein the lean zone is between the midpoint M and the melter exit end. Certain method embodiments may include wherein one or more SC burners is operated in pulsing mode. Certain method embodiments may include feeding large particle size feedstock (at least 10 cm APS) to the SCM inlet end.

[0039] Referring now to the drawing figures, specifically FIGS. 1, 2, and 11, FIG. 1 is a schematic side elevation view, partially in cross-section, of a prior art SCM system and method, where the SC burners are arranged in a 3 x 3 matrix of rows and columns, as illustrated schematically in the plan view of one melter floor plan in FIG. 11. The SCM includes a sidewall structure 2, floor 4, roof or ceiling 6, exhaust stack 8, and feed or feedstock inlet 10. For purposes of description, the SCM has a feed end (or first end) 12 and a melt exit end (or second end) 16, the latter having a melt exit 14. While not important to the various SCM burner profiling embodiments described herein, the SCM is typically fluidly connected to (but not necessarily structurally connected to) a melter exit structure 18. SCM further includes a refractory lining 20,

and a superstructure 22 that may comprise one or more fluid-cooled panels ("fluid-cooled" is a defined term herein). Also illustrated is a region of melter 24, one or more exhaust gas outlets that can be from the side or top of the SCM. Also illustrated schematically in FIG. 1 are positions of SC burners 26, 28, and 30, which are the centerline SC burners, turbulent melt 32 (with curved arrows indicating approximate flow pattern for burner profile of FIG. 2), and approximate surface 34 of turbulent melt 32.

[0040] Important to certain methods of the present disclosure are the definitions exemplified schematically in FIG. 11: R1, R2, and R3 designate the first row, second row, and third row of SC burners, where the first row R1 is closest to the feed end 12 of the SCM, and the third row R3 is closest to the melt exit end 16. There may be more or less than three rows of SC burners. Further defined in FIG. 11 are the length L of the SCM, the width W, the midpoint M, the centerline C, and the north N and south S sides of the SCM, the SCM having a feed end (F, same as 12) and exit end (E, same as 16), where F and E are deemed more generic than designations 12 and 16 illustrated in FIG. 1.

[0041] Referring now specifically to FIG. 2, FIG. 2 is a bar graph illustrating a prior method of operating the nine SC burners of FIG. 11 in the SCM of FIG. 1. This method of operation is referred to as a "flat profile". As indicated in the bar graph of FIG. 2, all burners are typically operated the same, that is, all burners R1N, R1C, R1S, R2N, R2C, R2S, R3N, R3C, and R3S producing equal portions of the total combustion flow (about 11.1 percent of total).

[0042] FIG. 3 is a line graph comparing tracer concentration (in this case ZnO) for two prior art methods of operating the SCM of FIGS. 1 and 11 with a method of the present disclosure. The SC burner "flat profile" of FIG. 2 is indicated (with solid diamonds), as well as a burner profile similar to the flat profile except with higher SC burner combustion flows nearer the feed end (indicated with solid squares). Contrast those with the burner profiles of the methods designated as embodiment 100, 200, and 300 in FIG. 4, one of which (embodiment 300) is indicated in FIG. 3 with solid triangles. It may be seen in FIG. 3 that the tracer concentration in the melt exit is much lower during the first 15 to 20 minutes for the burner profile of method embodiment 300 having higher percentage of total combustion flow near the exit end of the SCM R3 and when SC burners on both N and S sides of the SCM are operated with higher percentage of combustion flow than the C burners in the same row. Similar results were achieved for method embodiments 100 and 200. This was surprising and unexpected, as it was previously thought that the burner profile of the typical method, illustrated in FIG. 2, would produce the longest residence time for feedstock.

[0043] FIGS. 5 and 6 are schematic side elevation view, partially in cross-section, of an SCM and two alternate method embodiments 400 and 500, respectively, of operating the SCM in accordance with the present disclosure. Rather than adjusting position of burners and their percentage of total combustion flow rate, embodiment 400 seeks to improve quality of the melt by operating one or more SC burners in lean combustion mode, and other SC burners in rich fuel combustion mode, such that combustion is delayed until a region 36 of the turbulent melt is reached by the lean and rich combustion flows. This region 36 thus contributes to more heat of combustion being released in upper region 36, and more mixing of the melt, leading to greater homogeneity of the melt, and higher quality melt. Embodiment 500 illustrated schematically in FIG. 6 seeks to improve quality of the melt by operating one or more SC burners near the feed inlet end of the SCM in lean combustion mode, thus producing more mixing of the feedstock and the melt in this location without a significant increase in temperature. This operation of one or more SC burners in lean combustion mode may be positioned between the feed end of the SCM and the midpoint M of the SCM; or between the midpoint M and the melt exit end of the SCM, or near (or at) the midpoint M, at or near the centerline of the SCM.

[0044] FIGS. 7, 8, 9, and 10 are logic diagrams illustrating various methods of the present disclosure. FIG. 7 illustrates a method 600, which has at least two variations or two sub-embodiments, both having the same two initial steps, and both intended to maximize both mixing and melting in the SCM. Box 602, a method maximizing mixing and melting in an SCM, the method comprising (or consisting essentially of, or consisting of):

- (a) (box 604) melting an inorganic feedstock in an SCM using an arrangement of two or more SC burners, the SCM having a length L and a width W, a centerline C, a north side N and a south side S; and
- (b) (box 606) operating the arrangement of SC burners such that a progressively higher percentage of a total combustion flow from the SC burners occurs from SC burners at progressively downstream positions.

In sub-embodiment or option 1, box 608, the melting using an arrangement of two or more SC burners comprises melting with a matrix of at least two rows and at least two columns of SC burners wherein a row spans a majority of the width W and a column spans a majority of the length L of the SCM, and wherein the operating comprises

- (c) each SC burner in a first row R1 operates at a rate r_1 , each SC burner in a second row R2 operates at a rate r_2 , wherein $r_2 > r_1$.

In sub-embodiment or option 2, box 610, the melting using an arrangement of two or more SC burners comprises melting with a matrix of at least two rows and at least two columns of SC burners wherein a row spans a majority of the width W and a column spans a majority of the length L of the SCM, and wherein the operating comprises

(d) if the matrix is a two row by three column matrix or larger, SC burners on the N and S sides in the first row R1 operate at a rate r_3 , and SC burners in the center C of the first row R1 operate at a rate r_4 , where $r_3 > r_4$, and SC burners on N and S sides in a second row R2 operate at a rate r_5 and SC burners in the center C operate at a rate r_6 , where $r_5 > r_6 \geq r_4$, and $r_5 > r_3$.

[0045] FIG. 8 illustrates a method 700, which has at least two variations or two sub-embodiments, both having the same two initial steps, and both intended to maximize both mixing and melting in the SCM. Box 602, a method maximizing mixing and melting in an SCM, the method comprising (or consisting essentially of, or consisting of):

- (a) (box 604) melting an inorganic feedstock in an SCM using an arrangement of two or more SC burners, the SCM having a length L and a width W, a centerline C, a north side N and a south side S;
- (b) (box 702) operating the arrangement of SC burners such that a progressively lower percentage of total combustion flow rate from the SC burners occurs from SC burners at progressively downstream positions from the feed end of the SCM up to a midpoint M of the SCM length L, and such that a progressively higher percentage of total combustion flow rate from the SC burners occurs from SC burners at progressively downstream positions from the midpoint M to the melt exit end of the SCM.

In sub-embodiment or option 3, (box 704), the melting using an arrangement of two or more SC burners comprises melting with a matrix of at least two rows and at least two columns of SC burners wherein a row spans a majority of the width W and a column spans a majority of the length L of the SCM, and wherein the operating the arrangement of SC burners comprises operating the SC burners such that SC burners nearer the feed end of the SCM have a flow rate r_7 , SC burners near the melt exit end have a flow rate r_8 , and SC burners near an intersection of L and a midpoint M have a flow rate r_9 , wherein:

$$r_7 > r_9$$

$$r_8 > r_9,$$

and

$$r_8 \geq r_7.$$

In sub-embodiment or option 4, (box 706) the matrix is a 3 row x 3 column matrix, and SC burners on the N and S sides have flow rate greater than the center SC burners.

[0046] FIG. 9 illustrates a method 800, which has at least three variations or three sub-embodiments, each having the same two initial steps, and each intended to maximize both mixing and temperature increase in the SCM. Box 802, a method maximizing mixing and temperature increase in an SCM, the method comprising (or consisting essentially of, or consisting of):

- (a) (box 604) melting an inorganic feedstock in an SCM using an arrangement of two or more SC burners, the SCM having a length L and a width W, a centerline C, a north side N and a south side S; and
- (b) (box 804) operating the arrangement of SC burners such that SC burners in a first zone of the SCM operate fuel lean, and SC burners in a second zone of the SCM operate fuel rich, and where combustion products of the SC burners in the first zone mix with combustion products of the SC burners of the second zone at a position in the SCM higher than where the lean or rich combustion takes place.

In sub-embodiment or option 5, (box 806) the melting using an arrangement of two or more SC burners comprises melting with a matrix of at least two rows and at least two columns of SC burners wherein a row spans a majority of the width W and a column spans a majority of the length L of the SCM, and the matrix is a 3 row by 3 column matrix and the first zone is at a midpoint M of the SCM length L, and the second zone is downstream of the midpoint M of the SCM length L. In sub-embodiment or option 6, (box 808) the melting using an arrangement of two or more SC burners comprises melting with a matrix of at least two rows and at least two columns of SC burners wherein a row spans a

majority of the width W and a column spans a majority of the length L of the SCM, and the matrix is a 3 row by 3 column matrix and the first zone is at a midpoint M of the SCM length L, and the second zone is upstream of the midpoint M of the SCM length L. In sub-embodiment or option 12, (box 810) the first (lean) zone is near the feed inlet, and the second (fuel rich) zone is immediately downstream the first zone, and including feeding small (less than 1 mm APS) particle size batch material to the SCM in the feed inlet.

[0047] FIG. 10 illustrates a method 900, which has at least five variations or five sub-embodiments, each having the same two initial steps, and all intended to maximize mixing without substantially increasing temperature of the melt in the SCM. Box 902, a method maximizing mixing without substantially increasing temperature of melt in the SCM, the method comprising (or consisting essentially of, or consisting of):

- (a) (box 604) melting an inorganic feedstock in an SCM using an arrangement of two or more SC burners, the SCM having a length L and a width W, a centerline C, a north side N and a south side S; and
- (b) (box 904) operating the arrangement of SC burners such that SC burners in a first zone of the SCM operate fuel lean, and SC burners in all other zones of the SCM operate neither fuel rich nor fuel lean.

[0048] In sub-embodiment or option 7, (box 906) the lean zone is between the feed end of the SCM and the midpoint M. In sub-embodiment or option 8, (box 908) the lean zone is between the midpoint M and the SCM exit end. In sub-embodiment or option 9, (box 910) the lean zone is nearer the melter feed end than any other melting zone. In sub-embodiment or option 10, (box 912) one or more SC burners is operated in pulsing mode. In sub-embodiment or option 11, (box 914) the feeding large particle size feedstock (at least 10 cm APS) to the SCM inlet end.

[0049] In operation, flow of feedstock into the SCM may be continuous, semi-continuous, semi-batch, or batch. For example, in certain embodiments feedstock could flow into a feedstock heat exchange substructure until the feedstock heat exchange substructure is partially full or completely full of feedstock, then the pre-heated feedstock may be dumped into the SCM. One way of accomplishing that may be by use of a grating at the bottom of a feedstock heat exchange substructure having openings slightly smaller than the feedstock particle size. Such an arrangement is disclosed in assignee's co-pending U.S. Patent Application Serial No. 14/844,198, filed September 3, 2015, incorporated by reference herein.

[0050] The initial raw material feedstock may include any material suitable for forming molten inorganic materials. In certain embodiments where the feedstock is pre-heated by melter exhaust, the feedstock may have a weight average particle size such that most if not all of the feedstock is not fluidized when traversing through the heat exchange structure or exhaust conduit serving as the heat exchange structure. Such materials may include glass precursors or other non-metallic inorganic materials, such as, for example, limestone, glass cullet, feldspar, basalt or other rock wool forming material, and mixtures thereof. Typical examples of basalt that are compositionally stable and available in large quantities are reported in the afore-mentioned U.S. Patent Publication 20120104306, namely an ore having a larger amount of SiO₂ (A, for high-temperature applications) and an ore having a smaller amount of SiO₂ (B, for intermediate-temperature applications), both of which have approximately the same amount of Al₂O₃. Although ore A can be spun into fiber, the resultant basalt fiber has heat-resistance problem at temperature ranges exceeding 750° C. Ore B, on the other hand, is associated with higher energy cost for mass production of fiber. The basalt rock material feedstock for use on the systems and methods of the present disclosure may be selected from: (1) high-temperature ore (A) having substantially the same amount of Al₂O₃ and a larger amount of SiO₂; (2) intermediate-temperature ore (B) having substantially the same amount of Al₂O₃ and a smaller amount of SiO₂; and (3) a mixture of the high-temperature basalt rock ore (A) and the intermediate-temperature basalt rock ore (B).

[0051] Basalt rock (basalt ore) is an igneous rock. According to U.S. Patent Publication 20120104306, major examples of the constituent mineral include: (1) plagioclase: Na(AlSi₃O₈)-Ca(Al₂SiO₈); (2) pyroxene: (Ca, Mg, Fe²⁺, Fe³⁺, Al, Ti)₂[(Si, Al)₂O₆]; and (3) olivine: (Fe, Mg)₂SiO₄. Ukrainian products are inexpensive and good-quality.

[0052] Tables 1 and 2 (from U.S. Patent Publication 20120104306) show examples of element ratios (wt. %) and the oxide-equivalent composition ratios (wt. %) determined by ICP analysis (using an inductively-coupled plasma spectrometer ICPV-8100 by Shimadzu Corporation) performed on a high-temperature basalt ore (for high-temperature applications), an intermediate-temperature basalt ore (for intermediate-temperature applications), and a glass consisting of 85% high-temperature ore and 15% intermediate-temperature ore.

TABLE 1

	Ore (for high-temp.) (wt %)	Ore (for intermediate-temp.) (wt %)	Ore (for high-temp.) 85 wt % Ore (for intermediate-temp.) 15 wt % (wt %)
Si	23.5~28.8	23.5~28.5	25.0~28.8
Al	8.7~9.3	8.7~9.3	9.0~9.5
Fe	6.0~6.6	6.0~7.1	5.7~6.7

EP 3 144 282 A1

(continued)

	Ore (for high-temp.) (wt %)	Ore (for intermediate-temp.) (wt %)	Ore (for high-temp.) 85 wt % Ore (for intermediate-temp.) 15 wt % (wt %)
5	Ca 4.0~4.5	5.6~6.1	4.2~4.7
	Na 2.1~2.3	1.8~2.0	2.0~2.3
	K 1.4~1.8	1.2~1.5	1.4~1.9
	Mg 0.1~1.6	1.4~3.0	1.5~1.7
10	Ti 0.4~0.6	0.5~0.7	0.4~0.6
	Mn 0.1~0.2	0.1~0.2	0.1~0.2
	P 0.05~0.10	0.05~0.09	0.07~0.10
	B 0.02~0.08	0.01~0.06	0.03~0.10
	Ba 0.03~0.05	0.03~0.05	0.09
15	Sr 0.02~0.04	0.02~0.04	0.02~0.05
	Zr 0.01~0.04	0.01~0.04	0.01~0.03
	Cr 0.01~0.03	0.01~0.03	0.01~0.03
	S 0.01~0.03	0.01~0.03	0.01~0.03

20

TABLE 2

	Ore (for high-temp.) (wt %)	Ore (for intermediate-temp.) (wt %)	Ore (for high-temp.) 85 wt % Ore (for intermediate-temp.) 15 wt % (wt %)
25	SiO ₂ 57.1~61.2	54.0~58.2	57.7~60.6
	Al ₂ O ₃ 16.1~19.2	14.9~18.1	16.5~18.9
	FeO + Fe ₂ O ₃ 8.0~9.7	8.1~9.6	7.7~9.6
	CaO 5.5~6.8	7.5~8.8	5.8~7.0
30	Na ₂ O 2.8~3.3	2.2~2.9	2.6~3.2
	K ₂ O 1.8~2.1	1.4~1.8	1.8~2.2
	MgO 0.20~2.5	1.4~4.8	0.2~2.8
	TiO ₂ 0.7~1.0	0.8~1.1	0.1~0.3
	MnO 0.1~0.3	0.1~0.3	0.1~0.3
35	P ₂ O ₅ 0.1~0.3	0.1~0.3	0.1~0.3
	B ₂ O ₃ 0.1~0.3	0.04~0.20	0.04~0.30
	BaO 0.03~0.07	0.02~0.06	0.03~0.12
	SrO 0.02~0.06	0.02~0.07	0.01~0.06
40	ZrO ₂ 0.02~0.05	0.02~0.05	0.01~0.30
	Cr ₂ O ₃ 0.01~0.05	0.01~0.05	0.01~0.04
	SO 0.01~0.03	0.01~0.03	0.01~0.03

45 **[0053]** In embodiments wherein glass batch is used as sole or as a supplemental feedstock, one glass composition for producing glass fibers is "E-glass," which typically includes 52-56% SiO₂, 12-16% Al₂O₃, 0-0.8% Fe₂O₃, 16-25% CaO, 0-6% MgO, 0-10% B₂O₃, 0-2% Na₂O+K₂O, 0-1.5% TiO₂ and 0-1% F₂. Other glass batch compositions may be used, such as those described in assignee's published U.S. application 20080276652.

50 **[0054]** As noted herein, submerged combustion burners and burner panels may produce violent turbulence of the molten inorganic material in the SCM and may result in sloshing of molten material, pulsing of combustion burners, popping of large bubbles above submerged burners, ejection of molten material from the melt against the walls and ceiling of melter, and the like. Frequently, one or more of these phenomena may result in undesirably short life of temperature sensors and other components used to monitor a submerged combustion melter's operation, making monitoring difficult, and use of signals from these sensors for melter control all but impossible for more than a limited time period. Processes and systems of the present disclosure may include indirect measurement of melt temperature in the melter itself, as disclosed in assignee's U.S. Patent 9,096,453, using one or more thermocouples for monitoring and/or control of the melter, for example using a controller. A signal may be transmitted by wire or wirelessly from a thermocouple to a controller, which may control the melter by adjusting any number of parameters, for example feed rate of a feedstock

55

feeder may be adjusted through a signal, and one or more of fuel and/or oxidant conduits may be adjusted via a signal, it being understood that suitable transmitters and actuators, such as valves and the like, are not illustrated for clarity.

5 [0055] Melter apparatus in accordance with the present disclosure may also comprise one or more wall-mounted submerged combustion burners, and/or one or more roof-mounted burners (not illustrated). Roof-mounted burners may be useful to pre-heat the melter apparatus melting zone, and serve as ignition sources for one or more submerged combustion burners and/or burner panels. Roof-mounted burners may be oxy-fuel burners, but as they are only used in certain situations, are more likely to be air/fuel burners. Most often they would be shut-off after pre-heating the melter and/or after starting one or more submerged combustion burners. In certain embodiments, if there is a possibility of carryover of batch particles to the exhaust, one or more roof-mounted burners could be used to form a curtain to prevent particulate carryover. In certain embodiments, all submerged combustion burners and burner panels may be oxy/fuel burners or oxy-fuel burner panels (where "oxy" means oxygen, or oxygen-enriched air, as described earlier), but this is not necessarily so in all embodiments; some or all of the submerged combustion burners or burner panels may be air/fuel burners. Furthermore, heating may be supplemented by electrical (Joule) heating in certain embodiments, in certain melter zones.

15 [0056] Certain system embodiment may comprise burner panels as described in assignee's co-pending U.S. Patent Application Serial No. 14/838,148, filed August 27, 2015, comprising a burner panel body and one or more sets of concentric conduits for flow of oxidant and fuel. Certain burner panels disclosed therein include those wherein the outer conduit of at least some of the sets of concentric conduits are oxidant conduits, and the at least one inner conduit is one or more fuel conduits. Certain burner panel embodiments may comprise non-fluid cooled or fluid-cooled protective members comprising one or more noble metals. Certain burner panel embodiments may comprise non-fluid cooled or fluid-cooled protective members consisting essentially of one or more noble metals. Certain burner panel embodiments may comprise non-fluid cooled or fluid-cooled protective members consisting of one or more noble metals. Certain burner panel embodiments may comprise those wherein the lower fluid-cooled portion and the upper non-fluid cooled portion are positioned in layers, with the lower fluid-cooled portion supporting the sets of conduits and the associated protective members. Certain burner panel embodiments may comprise those wherein the non-fluid cooled protective member is a shaped annular disk having a through passage, the through passage of the shaped annular disk having an internal diameter substantially equal to but not larger than an internal diameter of the outer conduit. Certain burner panel embodiments may comprise those wherein an internal surface of the through passage of the shaped annular disk and a portion of a top surface of the shaped annular disk are not engulfed by the fluid-cooled or non-fluid-cooled portions of the panel body. Certain combustion burner panels may comprise a panel body having a first major surface defined by a lower fluid-cooled portion of the panel body, and a second major surface defined by an upper non-fluid cooled portion of the panel body, the panel body having at least one through passage extending from the first to the second major surface, the through passage diameter being greater in the lower fluid-cooled portion than in the upper non-fluid cooled portion, the panel body supporting at least one set of substantially concentric at least one inner conduit and an outer conduit, each conduit comprising proximal and distal ends, the at least one inner conduit forming a primary passage and the outer conduit forming a secondary passage between the outer conduit and the at least one inner conduit; and (b) a fluid-cooled protective member associated with each set and having connections for coolant fluid supply and return, each fluid-cooled protective member positioned adjacent at least a portion of the circumference of the outer conduit between the proximal and distal ends thereof at approximately a position of the fluid-cooled portion of the panel body. Certain burner panel embodiments may comprise those wherein each fluid-cooled protective member is a fluid-cooled collar having an internal diameter about the same as an external diameter of the outer conduit, the fluid-cooled collar having an external diameter larger than the internal diameter. Certain burner panel embodiments may comprise a mounting sleeve. In certain burner panel embodiments the mounting sleeve having a diameter at least sufficient to accommodate the external diameter of the fluid-cooled collar. In certain embodiments, the burner panel may include only one or more fuel conduits, or only one or more oxidant conduits. These embodiments may be paired with other panels supplying fuel or oxidant (as the case might be), the pair resulting in combustion of the fuel from one panel with the oxidant from the other panel. In certain embodiments the burner panel may comprise a pre-disposed layer or layers of glass, ceramic, refractory, and/or refractory metal or other protective material as a protective skull over the non-fluid cooled body portion or layer. The layer or layers of protective material may or may not be the same as the material to be melted in the SCM.

50 [0057] Suitable materials for glass-contact refractory, which may be present in SCMs, burners, and burner panels useful herein, include AZS (alumina-zirconia-silica), α/β alumina, zirconium oxide, chromium oxide, chrome corundum, so-called "dense chrome", and the like. One "dense chrome" material is available from Saint Gobain under the trade name SEFPRO, such as C1215 and C1221. Other useable "dense chrome" materials are available from the North American Refractories Co., Cleveland, Ohio (U.S.A.) under the trade designations SERV 50 and SERV 95. Other suitable materials for components that require resistance to high temperatures are fused zirconia (ZrO_2), fused cast AZS (alumina-zirconia-silica), rebonded AZS, or fused cast alumina (Al_2O_3). The choice of a particular material may be dictated by the geometry of the apparatus, the type of material being produced, operating temperature, burner body panel geometry,

and type of glass or other product being produced.

5 [0058] The term "fluid-cooled" means use of any coolant fluid (heat transfer fluid) to transfer heat away from the equipment in question, other than ambient air that resides naturally on the outside of the equipment. For example, portions of or the entire panels of sidewall structure, floor, and roof of the SCM, portions or all of heat transfer substructures used to preheat feedstock (for example nearest the melter), portions of feedstock supply conduits, and portions of SC burners, and the like may require fluid cooling. Heat transfer fluids may be any gaseous, liquid, slurry, or some combination of gaseous, liquid, and slurry compositions that functions or is capable of being modified to function as a heat transfer fluid. Gaseous heat transfer fluids may be selected from air, including ambient air and treated air (for example, air treated to remove moisture), inorganic gases, such as nitrogen, argon, and helium, organic gases such as fluoro-, chloro- and chlorofluorocarbons, including perfluorinated versions, such as tetrafluoromethane, and hexafluoroethane, and tetrafluoroethylene, and the like, and mixtures of inert gases with small portions of non-inert gases, such as hydrogen. Heat transfer liquids and slurries may be selected from liquids and slurries that may be organic, inorganic, or some combination thereof, for example, water, salt solutions, glycol solutions, oils and the like. Other possible heat transfer fluids include steam (if cooler than the expected glass melt temperature), carbon dioxide, or mixtures thereof with nitrogen. Heat transfer fluids may be compositions comprising both gas and liquid phases, such as the higher chlorofluorocarbons. Certain SCMs and method embodiments of this disclosure may include fluid-cooled panels such as disclosed in assignee's U.S. Patent No. 8,769,992.

10 [0059] Certain systems and processes of the present disclosure may utilize measurement and control schemes such as described in Applicant's U.S. Patent 9,096,453, and/or feed batch densification systems and methods as described in assignee's co-pending U.S. Patent Application Serial No. 13/540,704, filed July 3, 2012. Certain SCMs and processes of the present disclosure may utilize devices for delivery of treating compositions such as disclosed in assignee's U.S. Patent 8,973,405.

15 [0060] Certain systems, apparatus, and method embodiments of this disclosure may be controlled by one or more controllers. For example, combustion (flame) temperature may be controlled by monitoring one or more parameters selected from velocity of the fuel, velocity of the primary oxidant, mass and/or volume flow rate of the fuel, mass and/or volume flow rate of the primary oxidant, energy content of the fuel, temperature of the fuel as it enters burners or burner panels, temperature of the primary oxidant as it enters burners or burner panels, temperature of the effluent (exhaust) at melter exhaust exit, pressure of the primary oxidant entering burners or burner panels, humidity of the oxidant, burner or burner panel geometry, combustion ratio, and combinations thereof. Certain SCMs and processes of this disclosure may also measure and/or monitor feed rate of batch or other feedstock materials, such as rock wool or mineral wool feedstock, glass batch, cullet, mat or wound roving and treatment compositions, mass of feed, and use these measurements for control purposes. Flow diverter positions may be adjusted or controlled to increase heat transfer in heat transfer substructures and exhaust conduits.

20 [0061] Various conduits, such as feedstock supply conduits, exhaust conduits, oxidant and fuel conduits of burners or burner panels of the present disclosure may be comprised of metal, ceramic, ceramic-lined metal, or combination thereof. Suitable metals include carbon steels, stainless steels, for example, but not limited to, 306 and 316 steel, as well as titanium alloys, aluminum alloys, and the like. High-strength materials like C-110 and C-125 metallurgies that are NACE qualified may be employed for burner body components. (As used herein, "NACE" refers to the corrosion prevention organization formerly known as the National Association of Corrosion Engineers, now operating under the name NACE International, Houston, Texas.) Use of high strength steel and other high strength materials may significantly reduce the conduit wall thickness required, reducing weight of the conduits and/or space required for conduits. In certain locations, precious metals and/or noble metals (or alloys) may be used for portions or all of these conduits. Noble metals and/or other exotic corrosion and/or fatigue-resistant materials such as platinum (Pt), ruthenium (Ru), rhodium (Rh), palladium (Pd), silver (Ag), osmium (Os), iridium (Ir), and gold (Au); alloys of two or more noble metals; and alloys of one or more noble metals with a base metal may be employed. In certain embodiments a protective layer or layers or components may comprise an 80 wt. percent platinum/20 wt. percent rhodium alloy attached to a base metal using brazing, welding or soldering of certain regions, as further explained in assignee's published application WO2014189504.

25 [0062] The choice of a particular material is dictated among other parameters by the chemistry, pressure, and temperature of fuel and oxidant used and type of melt to be produced with certain feedstocks. The skilled artisan, having knowledge of the particular application, pressures, temperatures, and available materials, will be able design the most cost effective, safe, and operable heat transfer substructures, feedstock and exhaust conduits, burners, burner panels, and melters for each particular application without undue experimentation.

30 [0063] The total quantities of fuel and oxidant used by burners or burner panels of the present disclosure may be such that the flow of oxygen may range from about 0.9 to about 1.2 of the theoretical stoichiometric flow of oxygen necessary to obtain the complete combustion of the fuel flow. Another expression of this statement is that the combustion ratio may range from about 0.9 to about 1.2. The amount of heat needed to be produced by combustion of fuel in the melter (and/or Joule heating) will depend upon the efficiency of the preheating of the feedstock in the feedstock heat exchange substructure. The larger the amount of heat transferred to the feedstock, the lower the heat energy required in the melter

from the fuel and/or Joule elements. When operating "lean", the combustion ratio is above about 1.0, or above about 1.5, or above about 2.0, or above about 2.5. When operating "rich", the combustion ratio is below about 1.0, or below about 0.9, or below about 0.8, or below about 0.7, or below about 0.6, or below about 0.5, or below about 0.2.

[0064] In SCMs, the velocity of the fuel in the various burners and/or burner panel embodiments depends on the burner/burner panel geometry used, but generally is at least about 15 meters/second (m/s). The upper limit of fuel velocity depends primarily on the desired penetration of flame and/or combustion products into the glass melt and the geometry of the burner panel; if the fuel velocity is too low, the flame temperature may be too low, providing inadequate temperature in the melter, which is not desired, and if the fuel flow is too high, flame and/or combustion products might impinge on a melter wall or roof, or cause carryover of melt into the exhaust, or be wasted, which is also not desired. Baffles may be provided extending from the roof, and/or in the melter exhaust conduit, such as in the heat exchange substructure, in order to safeguard against this. Similarly, oxidant velocity should be monitored so that flame and/or combustion products do not impinge on an SCM wall or roof, or cause carryover of melt into the exhaust, or be wasted. Oxidant velocities depend on fuel flow rate and fuel velocity, but in general should not exceed about 200 ft/sec (60,96 m/s) at 400 scfh (11,33 m³/h) flow rate.

[0065] Although only a few exemplary embodiments of this disclosure have been described in detail above, those skilled in the art will readily appreciate that many modifications are possible in the exemplary embodiments without materially departing from the novel teachings and advantages of this disclosure. Accordingly, all such modifications are intended to be included within the scope of this disclosure as defined in the following claims. "Means for" clauses are intended to cover the structures, materials, and/or acts described herein as performing the recited function and not only structural equivalents, but also equivalent structures.

Claims

1. A method (600, 700) maximizing mixing and melting in an SCM, the method (600, 700, 800, 900) comprising:

(a) melting an inorganic feedstock in an SCM using an arrangement of two or more SC burners (R1 N, R1 C, R1 S, R2N, R2C, R2S, R3N, R3C, R3S), the SCM having a length (L) and a width (W), a centerline (C), a north side (N) and a south side (S); and

(b) operating the arrangement of SC burners (R1 N, R1 C, R1 S, R2N, R2C, R2S, R3N, R3C, R3S) such that a progressively higher percentage of a total combustion flow from the SC burners (R1 N, R1 C, R1 S, R2N, R2C, R2S, R3N, R3C, R3S) occurs from SC burners at progressively downstream positions.

2. The method (600, 700) in accordance with claim 1 wherein the melting using an arrangement of two or more SC burners (R1 N, R1 C, R1 S, R2N, R2C, R2S, R3N, R3C, R3S) comprises melting with a matrix of at least two rows (R1, R2, R3) and at least two columns of SC burners (R1 N, R1 C, R1 S, R2N, R2C, R2S, R3N, R3C, R3S) wherein a row (R1, R2, R3) spans a majority of the width (W) and a column spans a majority of the length (L) of the SCM, and wherein the operating is selected from the group consisting of:

(c) each SC burner (R1 N, R1 C, R1 S) in a first row (R1) operates at a rate r_1 , each SC burner (R2N, R2C, R2S) in a second row (R2) operates at a rate r_2 , wherein $r_2 > r_1$, and

(d) if the matrix is a two row (R1, R2, R3) by three column matrix or larger, SC burners (R1 N, R1 S) on the north side (N) and the south side (S) in the first row (R1) operate at a rate r_3 , and the SC burner (R1C) in the center (C) of the first row (R1) operates at a rate r_4 , where $r_3 > r_4$, and SC burners (R2N, R2S) on the north side (N) and the south side (S) in a second row (R2) operate at a rate r_5 and SC burners (R2C) in the center (C) operate at a rate r_6 , where $r_5 > r_6 \geq r_4$, and $r_5 > r_3$.

3. The method (600, 700) in accordance with one of the claims 1 or 2 wherein the melting using an arrangement of two or more SC burners (R1 N, R1 C, R1 S, R2N, R2C, R2S, R3N, R3C, R3S) comprises melting with a matrix of at least two rows (R1, R2, R3) and at least two columns of SC burners (R1 N, R1 C, R1 S, R2N, R2C, R2S, R3N, R3C, R3S) wherein a row spans a majority of the width (W) and a column spans a majority of the length (L) of the SCM, and wherein the operating comprises

(c) each SC burner (R1N, R1C, R1S) in a first row (R1) operates at a rate r_1 , each SC burner (R2N, R2C, R2S) in a second row (R2) operates at a rate r_2 , wherein $r_2 > r_1$.

4. The method (600, 700) in accordance with one of the claims 1 to 3 wherein the melting using an arrangement of two or more SC burners (R1 N, R1 C, R1 S, R2N, R2C, R2S, R3N, R3C, R3S) comprises melting with a matrix of

EP 3 144 282 A1

at least two rows (R1, R2, R3) and at least two columns of SC burners (R1 N, R1 C, R1 S, R2N, R2C, R2S, R3N, R3C, R3S) wherein a row (R1, R2, R3) spans a majority of the width (W) and a column spans a majority of the length (L) of the SCM, and wherein the operating comprises

5 (d) if the matrix is a two row (R1, R2, R3) by three column matrix or larger, SC burners (R1 N, R1 S) on the north side (N) and the south side (S) in the first row (R1) operate at a rate r_3 , and SC burners (R1 C) in the center (C) of the first row (R1) operate at a rate r_4 , where $r_3 > r_4$, and SC burners (R2N, R2S) on the north side (N) and south side (S) in a second row (R2) operate at a rate r_5 and SC burners (R1 C, R2C, R3C) in the center (C) operate at a rate r_6 , where $r_5 > r_6 \geq r_4$, and $r_5 > r_3$.

10 5. The method (600, 700) in accordance with one of the claims 1 to 4, wherein the progressively higher percentage of total combustion flow rate from the SC burners (R1 N, R1 C, R1 S, R2N, R2C, R2S, R3N, R3C, R3S) occurs from SC burners (R1 N, R1 C, R1 S, R2N, R2C, R2S, R3N, R3C, R3S) at progressively downstream positions from the midpoint (M) to the melt exit end (16, E) of the SCM, and

15 (b) operating the arrangement of SC burners (R1 N, R1 C, R1 S, R2N, R2C, R2S, R3N, R3C, R3S) such that a progressively lower percentage of total combustion flow rate from the SC burners (R1 N, R1 C, R1 S, R2N, R2C, R2S, R3N, R3C, R3S) occurs from SC burners (R1 N, R1 C, R1 S, R2N, R2C, R2S, R3N, R3C, R3S) at progressively downstream positions from the feed end (12, F) of the SCM up to a midpoint (M) of the SCM length (L).

20 6. The method (600, 700) in accordance with claim 5 wherein the melting using an arrangement of two or more SC burners (R1 N, R1 C, R1 S, R2N, R2C, R2S, R3N, R3C, R3S) comprises melting with a matrix of at least two rows (R1, R2, R3) and at least two columns of SC burners (R1 N, R1 C, R1 S, R2N, R2C, R2S, R3N, R3C, R3S) wherein a row (R1, R2, R3) spans a majority of the width (W) and a column spans a majority of the length (L) of the SCM, and wherein the operating the arrangement of SC burners (R1 N, R1 C, R1 S, R2N, R2C, R2S, R3N, R3C, R3S) comprises operating the SC burners (R1 N, R1 C, R1 S, R2N, R2C, R2S, R3N, R3C, R3S) such that SC burners (R1 N, R1 C, R1 S, R2N, R2C, R2S, R3N, R3C, R3S) nearer the feed end (12, F) of the SCM have a flow rate r_7 , SC burners (R1 N, R1 C, R1 S, R2N, R2C, R2S, R3N, R3C, R3S) near the melt exit end (16, E) have a flow rate r_8 , and SC burners (R1 N, R1 C, R1 S, R2N, R2C, R2S, R3N, R3C, R3S) near an intersection of length (L) and a midpoint (M) have a flow rate r_9 , wherein:

35
$$r_7 > r_9$$

$$r_8 > r_9,$$

40 and

$$r_8 \geq r_7.$$

45 7. The method (600, 700) in accordance with claim 6 wherein the matrix is a 3 row (R1, R2, R3) x 3 column matrix, and SC burners (R1 N, R1 S, R2N, R2S, R3N, R3S) on the north side (N) and south side (S) have flow rate greater than the center SC burners (R1 C, R2C, R3C).

50 8. The method (600, 700) in accordance with one of the claims 1 to 7 further comprising measuring concentration of a tracer compound or element in melt exiting the SCM to verify an increase in residence time of melt in the SCM compared to residence time of the melt when all SC burners are firing equally.

55 9. The method (600, 700) in accordance with claim 8 wherein the tracer compound or element is selected from the group consisting of ZnO (zinc oxide), SrCO₃ (strontium carbonate), BaCO₃ (barium carbonate), and Li₂CO₃ (lithium carbonate), and mixtures and combinations thereof.

10. A method (800) maximizing mixing and temperature increase in an SCM, the method comprising:

(a) melting an inorganic feedstock in an SCM using an arrangement of two or more SC burners (R1 N, R1 C, R1 S, R2N, R2C, R2S, R3N, R3C, R3S), the SCM having a length (L) and a width (W), a centerline (C), a north side (N) and a south side (S); and

(b) operating the arrangement of SC burners (R1 N, R1 C, R1 S, R2N, R2C, R2S, R3N, R3C, R3S) such that SC burners (R1 N, R1 C, R1 S, R2N, R2C, R2S, R3N, R3C, R3S) in a first zone of the SCM operate fuel lean, and SC burners (R1 N, R1 C, R1 S, R2N, R2C, R2S, R3N, R3C, R3S) in a second zone of the SCM operate fuel rich, and where combustion products of the SC burners (R1 N, R1 C, R1 S, R2N, R2C, R2S, R3N, R3C, R3S) in the first zone mix with combustion products of the SC burners (R1 N, R1 C, R1 S, R2N, R2C, R2S, R3N, R3C, R3S) of the second zone at a position in the SCM higher than where the lean or rich combustion takes place.

11. The method (800) in accordance with claim 10 wherein the melting using an arrangement of two or more SC burners (R1 N, R1 C, R1 S, R2N, R2C, R2S, R3N, R3C, R3S) comprises melting with a matrix of at least two rows (R1, R2, R3) and at least two columns of SC burners (R1 N, R1 C, R1 S, R2N, R2C, R2S, R3N, R3C, R3S) wherein a row (R1, R2, R3) spans a majority of the width (W) and a column spans a majority of the length (L) of the SCM.

12. The method (800) in accordance with claim 11 wherein the matrix is a 3 row (R1, R2, R3) by 3 column matrix and the first zone is at a midpoint (M) of the SCM length (L), and the second zone is upstream or downstream of the midpoint (M) of the SCM length (L).

13. The method (800) in accordance with one of the claims 10 to 12 wherein the first zone is near the feed inlet (10), and the second zone is immediately downstream the first zone, and including feeding small particle size batch material to the SCM in the feed inlet (10), wherein the particle size is preferably less than 1 mm APS.

14. A method (900) of maximizing mixing without substantially increasing temperature in an SCM, the method comprising:

(a) melting an inorganic feedstock in an SCM using an arrangement of two or more SC burners (R1N, R1C, R1S, R2N, R2C, R2S, R3N, R3C, R3S), the SCM having a length (L) and a width (W), a centerline (C), a north side (N) and a south side (S); and

(b) operating the arrangement of SC burners (R1 N, R1 C, R1 S, R2N, R2C, R2S, R3N, R3C, R3S) such that SC burners (R1 N, R1 C, R1 S, R2N, R2C, R2S, R3N, R3C, R3S) in a first zone of the SCM operate fuel lean, and SC burners (R1 N, R1 C, R1 S, R2N, R2C, R2S, R3N, R3C, R3S) in all other zones of the SCM operate neither fuel rich nor fuel lean.

15. The method (900) in accordance with claim 14 wherein the lean zone is between the feed end (12, F) of the SCM and the midpoint (M), wherein the lean zone is preferably nearer the melter feed end (12, F) than any other melting zone.

16. The method (900) in accordance with claim 15 wherein the lean zone is between the midpoint (M) and the melter exit end (16, E).

17. The method (900) in accordance with one of the claims 14 to 16 wherein one or more SC burners (R1 N, R1 C, R1 S, R2N, R2C, R2S, R3N, R3C, R3S) is operated in pulsing mode.

18. The method (900) in accordance with claim 15 comprising feeding large particle size feedstock, preferably having at least 10 cm APS, to the SCM inlet end.

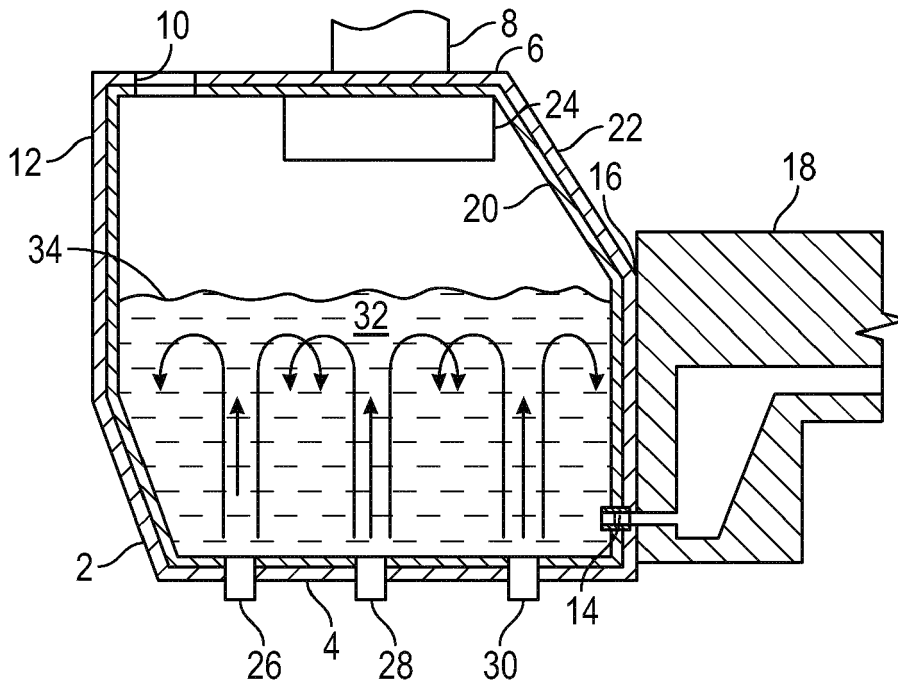

FIG. 1
(Prior Art)

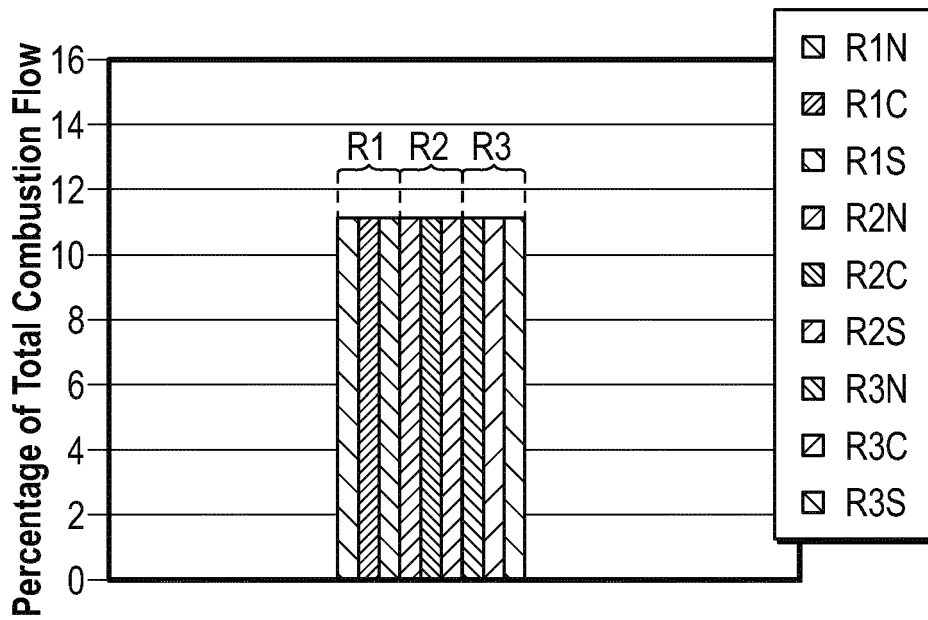

FIG. 2
(Prior Art)

Tracer Studies for Various Burner Profiles

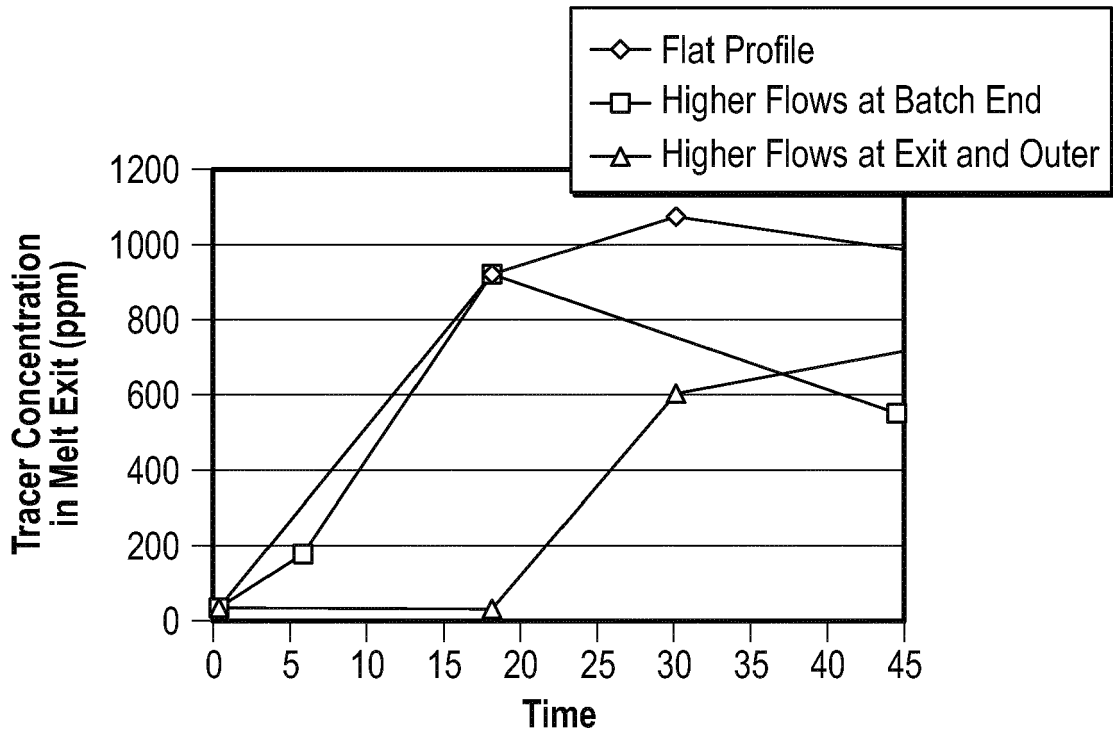

FIG. 3

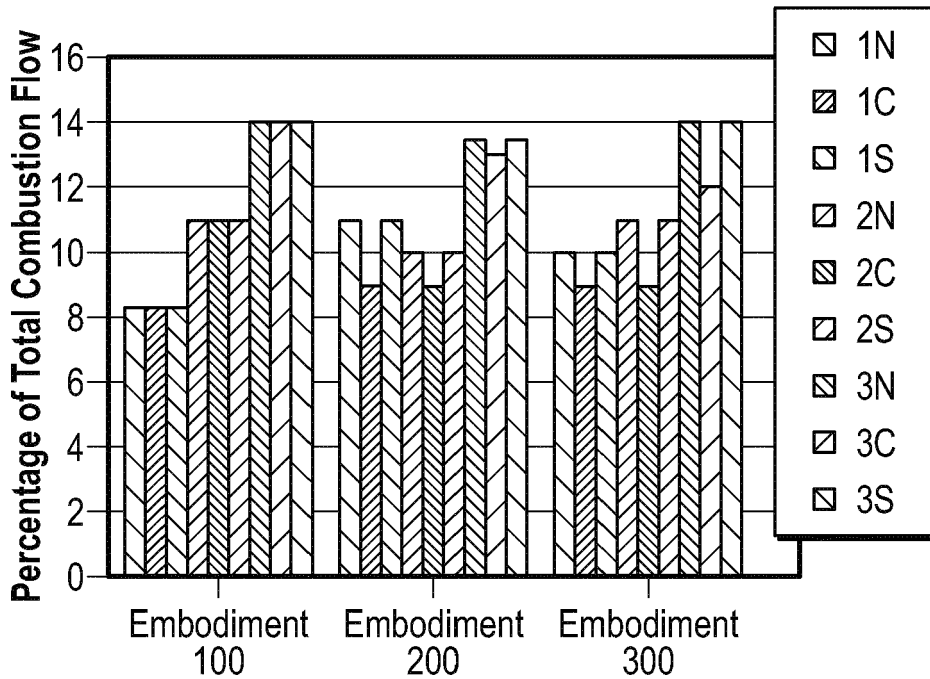

FIG. 4

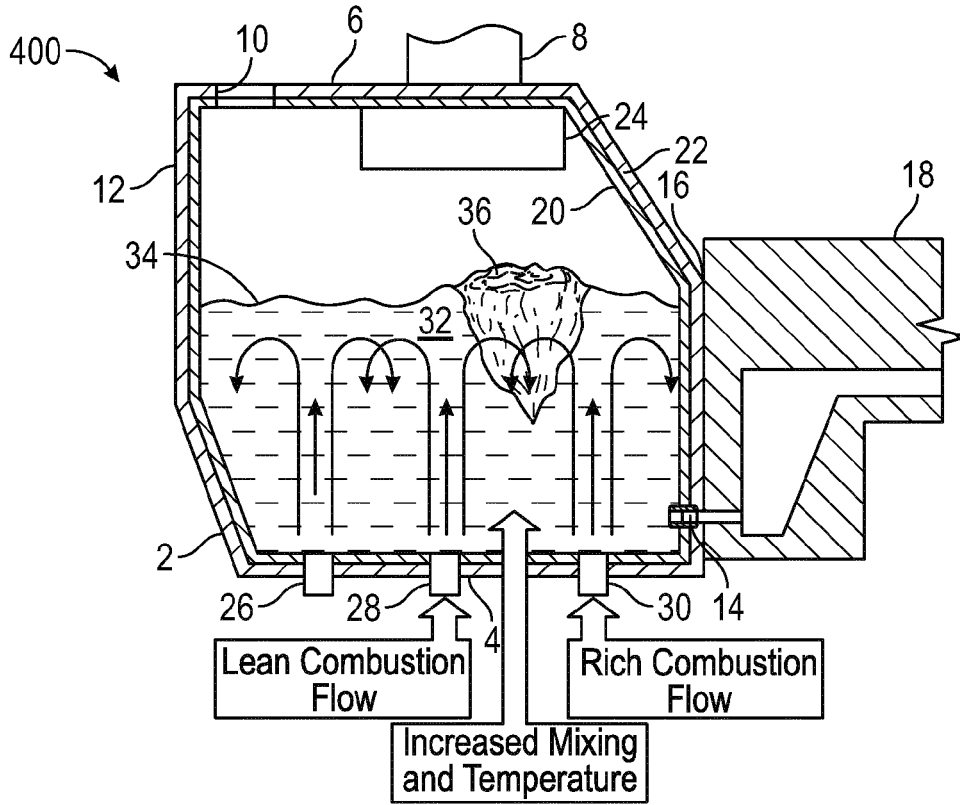

FIG. 5

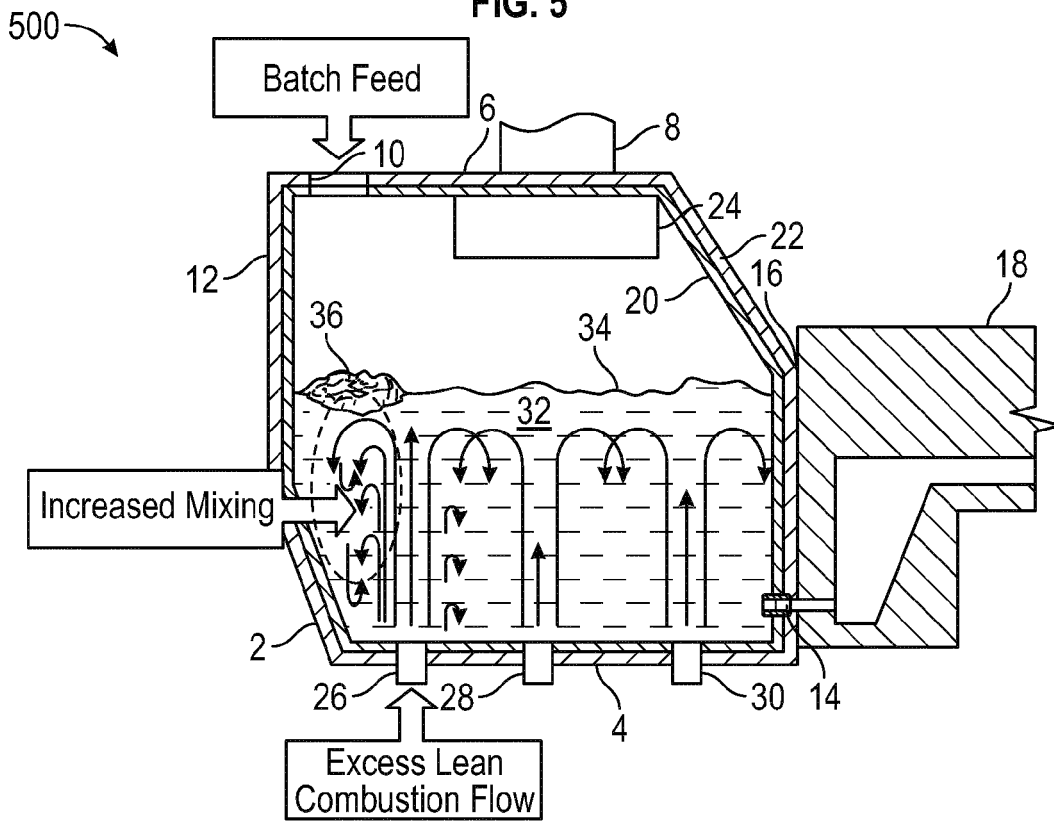

FIG. 6

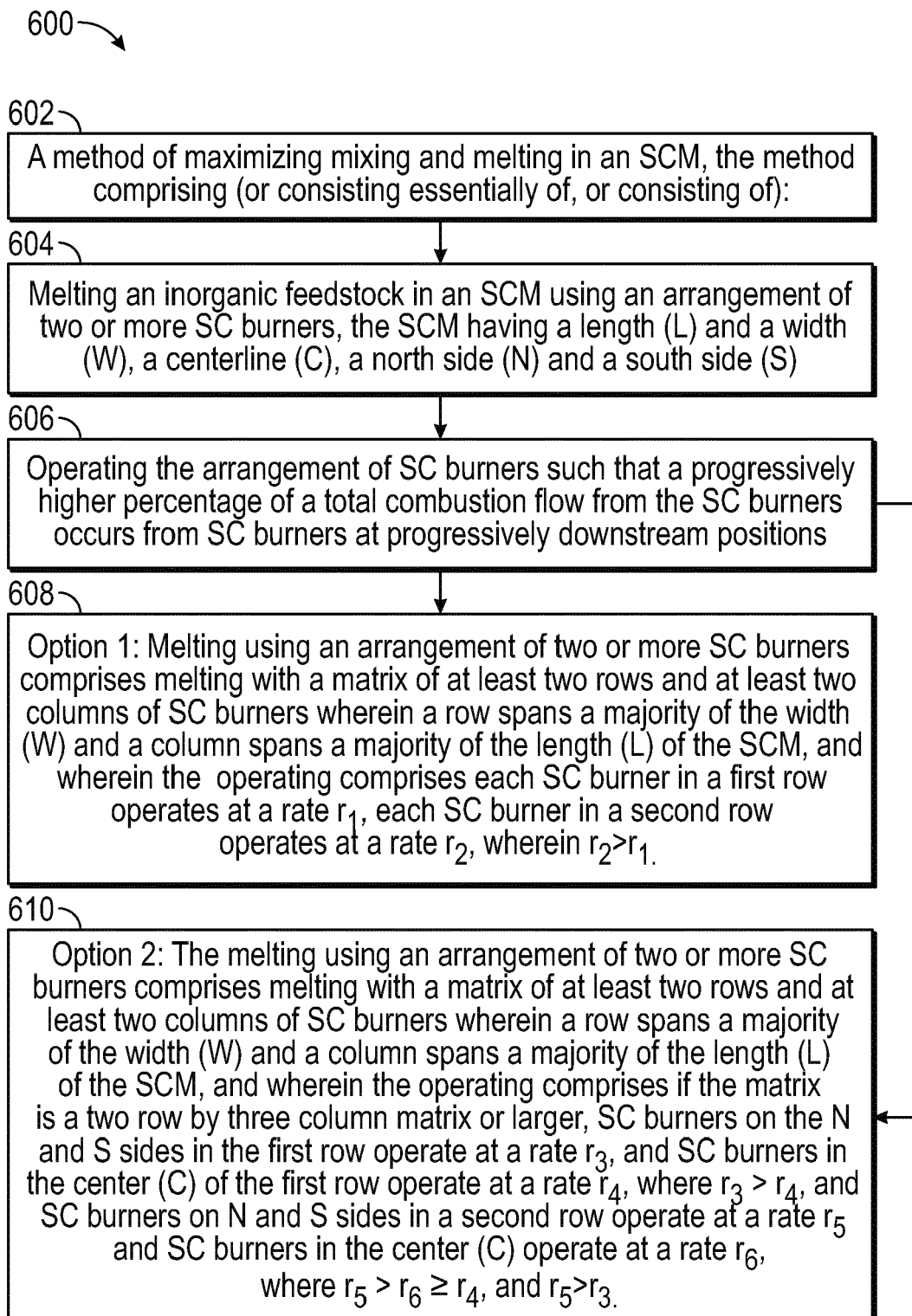

FIG. 7

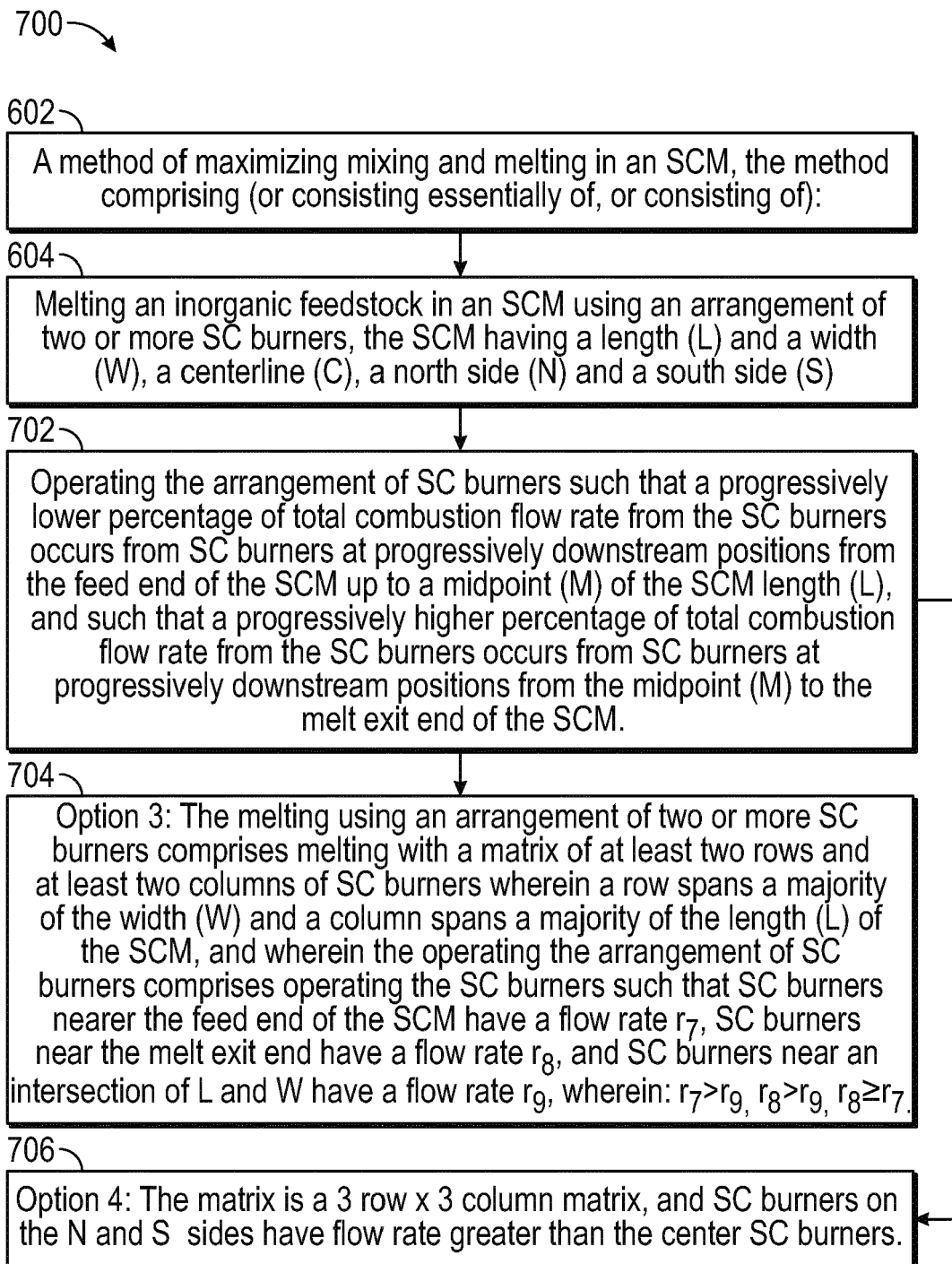

FIG. 8

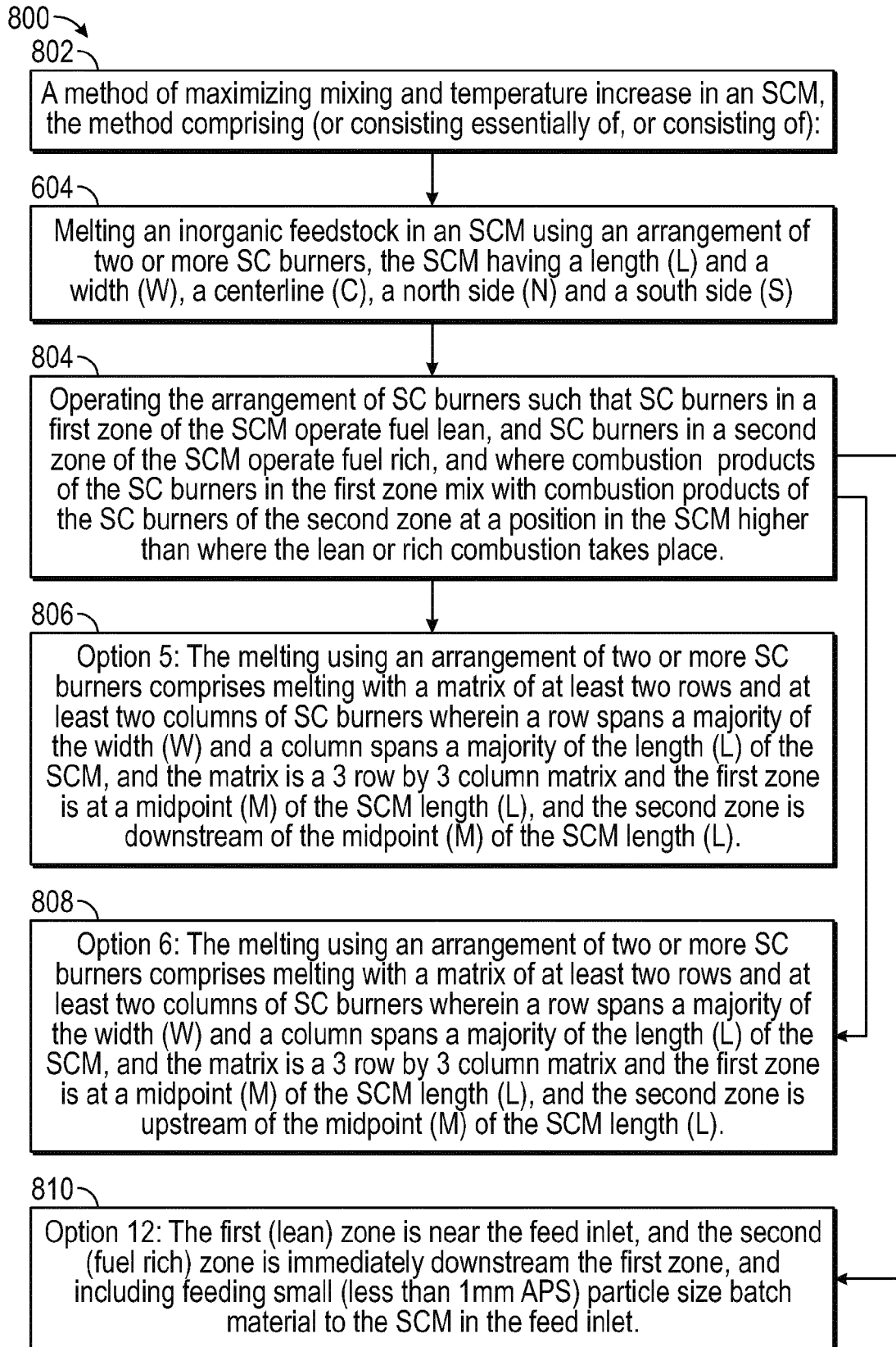

FIG. 9

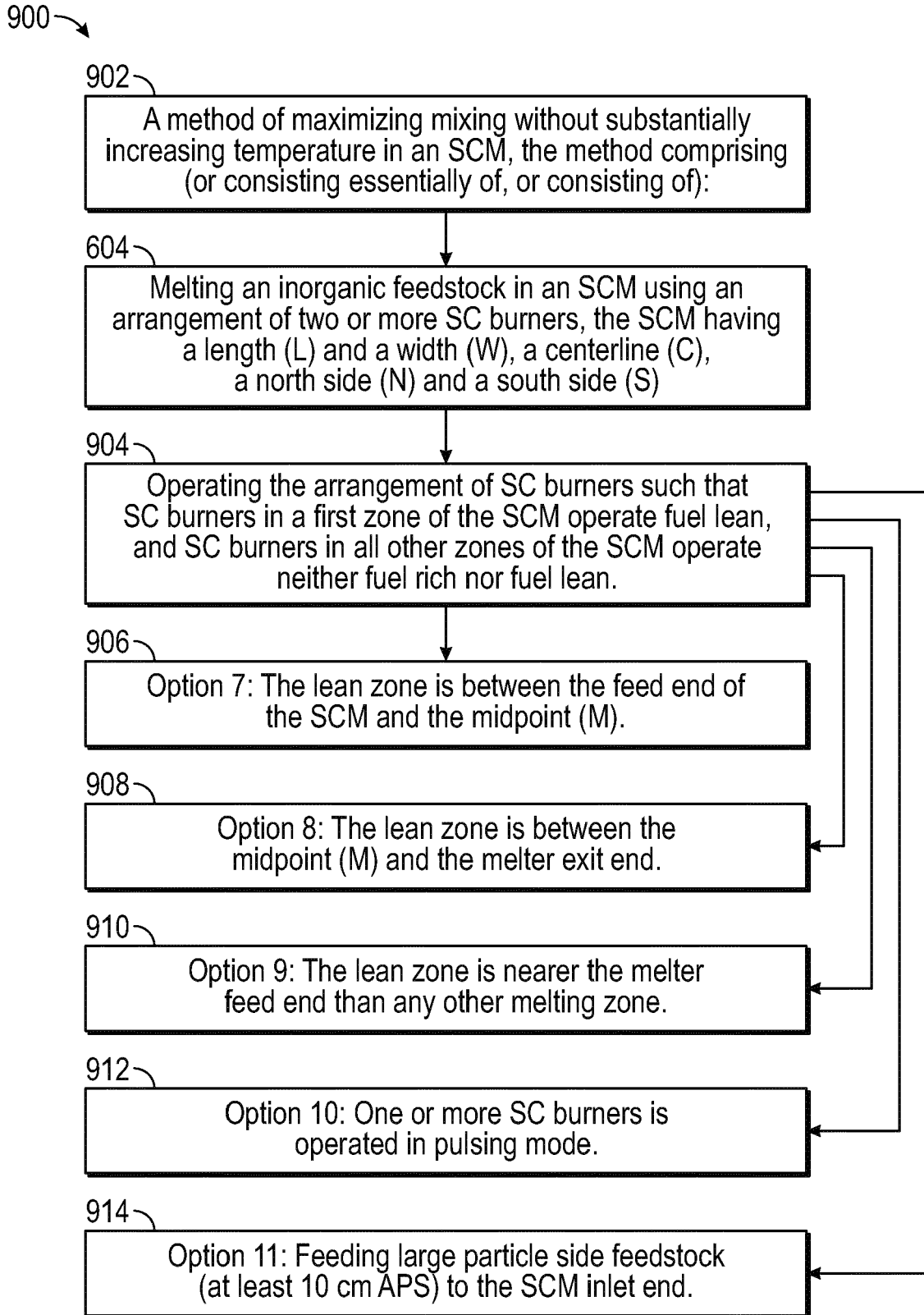

FIG. 10

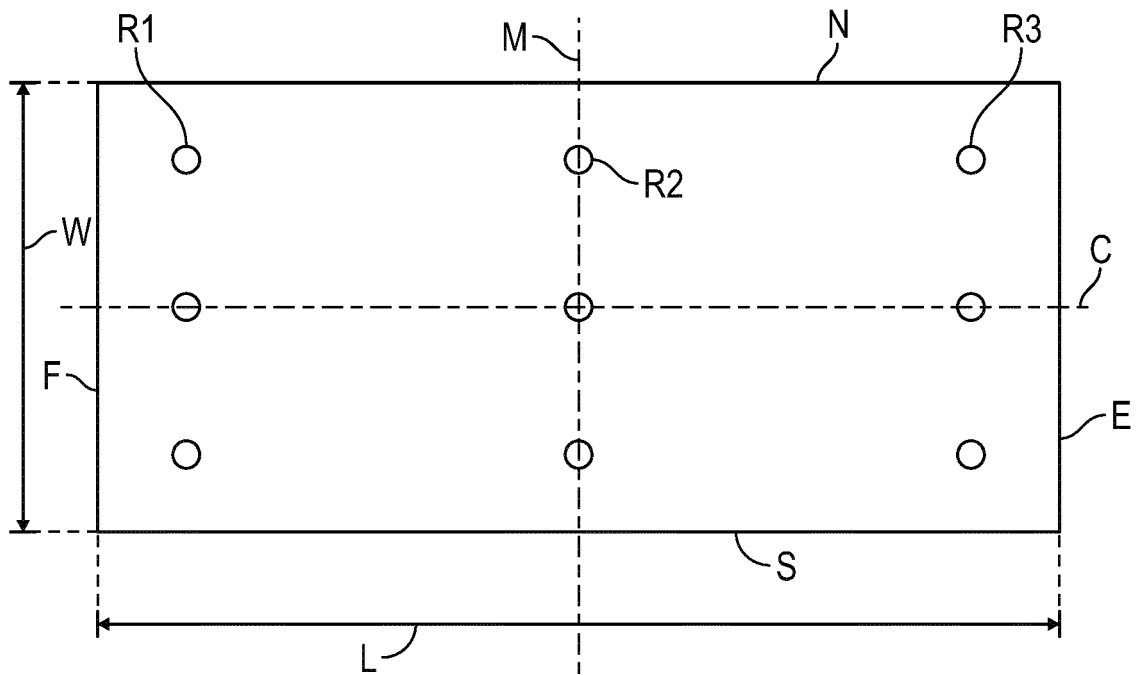

FIG. 11



EUROPEAN SEARCH REPORT

Application Number
EP 16 18 8859

5

10

15

20

25

30

35

40

45

50

55

DOCUMENTS CONSIDERED TO BE RELEVANT			
Category	Citation of document with indication, where appropriate, of relevant passages	Relevant to claim	CLASSIFICATION OF THE APPLICATION (IPC)
X	SU 425 853 A2 (R P POLEVOJ; V I BABICH; D A KRYUCHENKOV) 30 April 1974 (1974-04-30)	1,2,8,9	INV. C03B5/235
Y	* page 1; figures 1-2 *	3-7, 10-18	
Y	US 2011/236846 A1 (RUE DAVID M [US] ET AL) 29 September 2011 (2011-09-29) * paragraphs [0023], [0040] - [0041] *	3-7, 10-14,18	
A	WO 2013/152012 A1 (ECLIPSE [US]) 10 October 2013 (2013-10-10) * page 3, lines 1-3 *	3-7	
A	WO 2012/005768 A1 (JURANITCH JAMES CHARLES; REYNOLDS ALAN C [US]) 12 January 2012 (2012-01-12) * claims 9-13 *	3-7	
A	US 2004/174920 A1 (POPENOV ALEX [US] ET AL) 9 September 2004 (2004-09-09) * paragraph [0074] *	17	
Y	US 2010/068665 A1 (LEROUX BERTRAND [FR] ET AL) 18 March 2010 (2010-03-18) * paragraph [0028] *	10-18	TECHNICAL FIELDS SEARCHED (IPC) C03B F27B F23N F23G
Y,D	US 2008/276652 A1 (BAUER JON FREDERICK [US] ET AL) 13 November 2008 (2008-11-13) * paragraph [0013] *	10-18	
The present search report has been drawn up for all claims			
Place of search The Hague		Date of completion of the search 27 January 2017	Examiner Gkerou, Elisavet
CATEGORY OF CITED DOCUMENTS X : particularly relevant if taken alone Y : particularly relevant if combined with another document of the same category A : technological background O : non-written disclosure P : intermediate document		T : theory or principle underlying the invention E : earlier patent document, but published on, or after the filing date D : document cited in the application L : document cited for other reasons & : member of the same patent family, corresponding document	

EPO FORM 1503 03.82 (P04C01)

ANNEX TO THE EUROPEAN SEARCH REPORT
ON EUROPEAN PATENT APPLICATION NO.

EP 16 18 8859

5 This annex lists the patent family members relating to the patent documents cited in the above-mentioned European search report.
The members are as contained in the European Patent Office EDP file on
The European Patent Office is in no way liable for these particulars which are merely given for the purpose of information.

27-01-2017

Patent document cited in search report	Publication date	Patent family member(s)	Publication date
SU 425853 A2	30-04-1974	NONE	
US 2011236846 A1	29-09-2011	US 2011236846 A1 WO 2009091558 A1	29-09-2011 23-07-2009
WO 2013152012 A1	10-10-2013	CN 104508373 A RU 2014144438 A US 2013260323 A1 WO 2013152012 A1	08-04-2015 27-05-2016 03-10-2013 10-10-2013
WO 2012005768 A1	12-01-2012	CA 2804605 A1 EP 2591286 A1 US 2013318968 A1 WO 2012005768 A1	12-01-2012 15-05-2013 05-12-2013 12-01-2012
US 2004174920 A1	09-09-2004	AU 2003285652 A1 US 2004174920 A1 WO 2004065643 A1	13-08-2004 09-09-2004 05-08-2004
US 2010068665 A1	18-03-2010	BR PI0518522 A2 CN 101095011 A EP 1836438 A1 FR 2880410 A1 JP 4902550 B2 JP 2008527292 A US 2010068665 A1 WO 2006072724 A1	25-11-2008 26-12-2007 26-09-2007 07-07-2006 21-03-2012 24-07-2008 18-03-2010 13-07-2006
US 2008276652 A1	13-11-2008	EP 1990321 A1 US 2008276652 A1	12-11-2008 13-11-2008

EPO FORM P0459

For more details about this annex : see Official Journal of the European Patent Office, No. 12/82

REFERENCES CITED IN THE DESCRIPTION

This list of references cited by the applicant is for the reader's convenience only. It does not form part of the European patent document. Even though great care has been taken in compiling the references, errors or omissions cannot be excluded and the EPO disclaims all liability in this regard.

Patent documents cited in the description

- US 85427115 A [0001]
- US 83814815 A [0015] [0056]
- US 84419815 A [0017] [0049]
- US 20120104306 A [0050] [0051] [0052]
- US 20080276652 A [0053]
- US 9096453 B [0054] [0059]
- US 8769992 B [0058]
- US 54070412 A [0059]
- US 8973405 B [0059]
- WO 2014189504 A [0061]