



(11) **EP 3 716 698 A1**

(12) **EUROPEAN PATENT APPLICATION**

(43) Date of publication:  
**30.09.2020 Bulletin 2020/40**

(51) Int Cl.:  
**H04W 52/02 (2009.01)**

(21) Application number: **20166431.5**

(22) Date of filing: **27.03.2020**

(84) Designated Contracting States:  
**AL AT BE BG CH CY CZ DE DK EE ES FI FR GB GR HR HU IE IS IT LI LT LU LV MC MK MT NL NO PL PT RO RS SE SI SK SM TR**  
Designated Extension States:  
**BA ME**  
Designated Validation States:  
**KH MA MD TN**

• **Xu, Kai**  
**Reston, VA 20190 (US)**

(72) Inventors:  
• **Yi, Yunjung**  
**Reston, VA 20190 (US)**  
• **Dinan, Esmael**  
**Reston, VA 20190 (US)**  
• **Zhou, Hua**  
**Reston, VA 20190 (US)**  
• **Park, Kyungmin**  
**Reston, VA 20190 (US)**  
• **Jeon, Hyongsuk**  
**Reston, VA 20190 (US)**  
• **Babaei, Alireza**  
**Reston, VA 20190 (US)**  
• **Xu, Kai**  
**Reston, VA 20190 (US)**

(30) Priority: **28.03.2019 US 201962825293 P**

(71) Applicants:  
• **Yi, Yunjung**  
**Reston, VA 20190 (US)**  
• **Dinan, Esmael**  
**Reston, VA 20190 (US)**  
• **Zhou, Hua**  
**Reston, VA 20190 (US)**  
• **Park, Kyungmin**  
**Reston, VA 20190 (US)**  
• **Jeon, Hyongsuk**  
**Reston, VA 20190 (US)**  
• **Babaei, Alireza**  
**Reston, VA 20190 (US)**

(74) Representative: **Westphal, Mussgnug & Partner**  
**Patentanwälte mbB**  
**Werinherstrasse 79**  
**81541 München (DE)**

(54) **CROSS-CARRIER SCHEDULING ACTIVATION FOR A DORMANT CELL**

(57) A wireless device receives one or more radio resource control (RRC) messages comprising configuration parameters. The configuration parameters indicate a first secondary cell (SCell) group comprising one or more first cells and a second SCell group comprising a plurality of second cells. The wireless device activates, in a non-dormant state, the one or more first cells and the plurality of second cells. In response to receiving a downlink control information indicating transitioning the first SCell group to a dormant state, the wireless device transitions the one or more first cells to the dormant state and maintains the plurality of second cells in the non-dormant state.

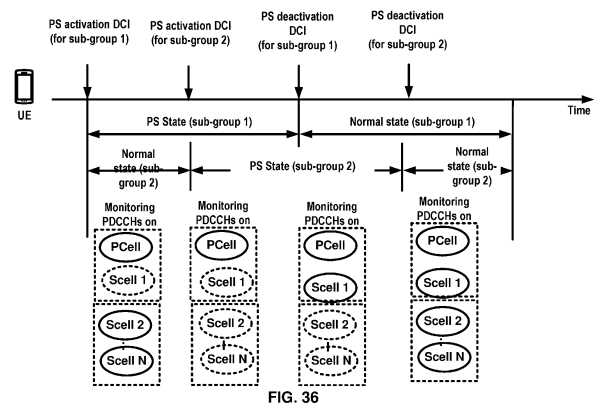

**EP 3 716 698 A1**

**Description****CROSS-REFERENCE TO RELATED APPLICATIONS**

5 **[0001]** This application claims the benefit of U.S. Provisional Application No. 62/825,293, filed March 28, 2019, which is hereby incorporated by reference in its entirety.

**BRIEF DESCRIPTION OF THE SEVERAL VIEWS OF THE DRAWINGS**

10 **[0002]** Examples of several of the various embodiments of the present disclosure are described herein with reference to the drawings.

FIG. 1 is a diagram of an example RAN architecture as per an aspect of an embodiment of the present disclosure.

15 FIG. 2A is a diagram of an example user plane protocol stack as per an aspect of an embodiment of the present disclosure.

FIG. 2B is a diagram of an example control plane protocol stack as per an aspect of an embodiment of the present disclosure.

FIG. 3 is a diagram of an example wireless device and two base stations as per an aspect of an embodiment of the present disclosure.

20 FIG. 4A, FIG. 4B, FIG. 4C and FIG. 4D are example diagrams for uplink and downlink signal transmission as per an aspect of an embodiment of the present disclosure.

FIG. 5A is a diagram of an example uplink channel mapping and example uplink physical signals as per an aspect of an embodiment of the present disclosure.

25 FIG. 5B is a diagram of an example downlink channel mapping and example downlink physical signals as per an aspect of an embodiment of the present disclosure.

FIG. 6 is a diagram depicting an example transmission time or reception time for a carrier as per an aspect of an embodiment of the present disclosure.

FIG. 7A and FIG. 7B are diagrams depicting example sets of OFDM subcarriers as per an aspect of an embodiment of the present disclosure.

30 FIG. 8 is a diagram depicting example OFDM radio resources as per an aspect of an embodiment of the present disclosure.

FIG. 9A is a diagram depicting an example CSI-RS and/or SS block transmission in a multi-beam system.

FIG. 9B is a diagram depicting an example downlink beam management procedure as per an aspect of an embodiment of the present disclosure.

35 FIG. 10 is an example diagram of configured BWPs as per an aspect of an embodiment of the present disclosure.

FIG. 11A, and FIG. 11B are diagrams of an example multi connectivity as per an aspect of an embodiment of the present disclosure.

FIG. 12 is a diagram of an example random access procedure as per an aspect of an embodiment of the present disclosure.

40 FIG. 13 is a structure of example MAC entities as per an aspect of an embodiment of the present disclosure.

FIG. 14 is a diagram of an example RAN architecture as per an aspect of an embodiment of the present disclosure.

FIG. 15 is a diagram of example RRC states as per an aspect of an embodiment of the present disclosure.

FIG. 16A, FIG. 16B and FIG. 16C are examples of MAC subheaders as per an aspect of an embodiment of the present disclosure.

45 FIG. 17A and FIG. 17B are examples of MAC PDUs as per an aspect of an embodiment of the present disclosure.

FIG. 18 is an example of LCIDs for DL-SCH as per an aspect of an embodiment of the present disclosure.

FIG. 19 is an example of LCIDs for UL-SCH as per an aspect of an embodiment of the present disclosure.

FIG. 20A is an example of an SCell Activation/Deactivation MAC CE of one octet as per an aspect of an embodiment of the present disclosure.

50 FIG. 20B is an example of an SCell Activation/Deactivation MAC CE of four octets as per an aspect of an embodiment of the present disclosure.

FIG. 21A is an example of an SCell hibernation MAC CE of one octet as per an aspect of an embodiment of the present disclosure.

55 FIG. 21B is an example of an SCell hibernation MAC CE of four octets as per an aspect of an embodiment of the present disclosure.

FIG. 21C is an example of MAC control elements for an SCell state transitions as per an aspect of an embodiment of the present disclosure.

FIG. 22 is an example of DCI formats as per an aspect of an embodiment of the present disclosure.

FIG. 23 is an example of BWP management on an SCell as per an aspect of an embodiment of the present disclosure.  
 FIG. 24 is an example of discontinuous reception (DRX) operation as per an aspect of an embodiment of the present disclosure.

FIG. 25 is an example of DRX operation as per an aspect of an embodiment of the present disclosure.

5 FIG. 26A is an example of a wake-up signal/channel based power saving operation as per an aspect of an embodiment of the present disclosure.

FIG. 26B is an example of a go-to-sleep signal/channel based power saving operation as per an aspect of an embodiment of the present disclosure.

FIG. 27 is an example of embodiments.

10 FIG. 28 is an example of bandwidth part related higher layer configurations.

FIG. 29 is an example of bandwidth part related higher layer configurations to support a cross-carrier scheduling.

FIG. 30 is an example of embodiment of DRX operation.

FIG. 31 is an example of embodiment of DRX operation with a dormant state.

FIG. 32 shows an example embodiment of monitoring one or more search space sets.

15 FIG. 33 shows an example embodiment of monitoring one or more search space sets.

FIG. 34 shows an example embodiment with a wake-up signal.

FIG. 35 shows an example embodiment with a wake-up signal.

FIG. 36 shows an example embodiment of transition between a dormant state and a normal state based on a DCI.

FIG. 37 shows an example embodiment on a plurality of cells/BWPs.

20 FIG. 38 shows an example embodiment on DCI format size determination.

FIG. 39 shows an example embodiment on a plurality of cells/BWPs.

FIG. 40 shows an example embodiment on a plurality of cells/BWPs.

FIG. 41 shows an example diagram of the embodiment based on a DCI mechanism.

FIG. 42 shows an example diagram of the embodiment based on a DRX mechanism.

25 FIG. 43 is a flow diagram of a method performed by a wireless device as per an aspect of an example embodiment of the present disclosure.

FIG. 44 is a flow diagram of a method performed by a base station as per an aspect of an example embodiment of the present disclosure.

30 **DETAILED DESCRIPTION OF EMBODIMENTS**

**[0003]** Example embodiments of the present disclosure enable wake-up procedure and power saving operations of a wireless device and/or one or more of base station(s). Embodiments of the technology disclosed herein may be employed in the technical field of multicarrier communication systems operated by one or more of base station(s). More particularly, the embodiments of the technology disclosed herein may relate to a wireless device and/or one or more of base station(s) in a multicarrier communication system.

**[0004]** The following Acronyms are used throughout the present disclosure:

3GPP	3rd Generation Partnership Project
40 5GC	5G Core Network
ACK	Acknowledgement
AMF	Access and Mobility Management Function
ARQ	Automatic Repeat Request
AS	Access Stratum
45 ASIC	Application-Specific Integrated Circuit
BA	Bandwidth Adaptation
BCCH	Broadcast Control Channel
BCH	Broadcast Channel
BPSK	Binary Phase Shift Keying
50 BWP	Bandwidth Part
CA	Carrier Aggregation
CC	Component Carrier
CCCH	Common Control Channel
CDMA	Code Division Multiple Access
55 CN	Core Network
CP	Cyclic Prefix
CP-OFDM	Cyclic Prefix- Orthogonal Frequency Division Multiplex
C-RNTI	Cell-Radio Network Temporary Identifier

	CS	Configured Scheduling
	CSI	Channel State Information
	CSI-RS	Channel State Information-Reference Signal
	CQI	Channel Quality Indicator
5	CRC	Cyclic Redundancy Check
	CSS	Common Search Space
	CU	Central Unit
	DAI	Downlink Assignment Index
	DC	Dual Connectivity
10	DCCH	Dedicated Control Channel
	DCI	Downlink Control Information
	DL	Downlink
	DL-SCH	Downlink Shared CHannel
	DM-RS	DeModulation Reference Signal
15	DRB	Data Radio Bearer
	DRX	Discontinuous Reception
	DTCH	Dedicated Traffic Channel
	DU	Distributed Unit
	EPC	Evolved Packet Core
20	E-UTRA	Evolved UMTS Terrestrial Radio Access
	E-UTRAN	Evolved-Universal Terrestrial Radio Access Network
	FDD	Frequency Division Duplex
	FPGA	Field Programmable Gate Arrays
	F1-C	F1-Control plane
25	F1-U	F1-User plane
	gNB	next generation Node B
	HARQ	Hybrid Automatic Repeat reQuest
	HDL	Hardware Description Languages
	IE	Information Element
30	IP	Internet Protocol
	LCID	Logical Channel Identifier
	LTE	Long Term Evolution
	MAC	Media Access Control
	MCG	Master Cell Group
35	MCS	Modulation and Coding Scheme
	MeNB	Master evolved Node B
	MIB	Master Information Block
	MME	Mobility Management Entity
	MN	Master Node
40	NACK	Negative Acknowledgement
	NAS	Non-Access Stratum
	NG CP	Next Generation Control Plane
	NGC	Next Generation Core
	NG-C	NG-Control plane
45	ng-eNB	next generation evolved Node B
	NG-U	NG-User plane
	NR	New Radio
	NR MAC	New Radio MAC
	NR PDCP	New Radio PDCP
50	NR PHY	New Radio PHYsical
	NR RLC	New Radio RLC
	NR RRC	New Radio RRC
	NSSAI	Network Slice Selection Assistance Information
	O&M	Operation and Maintenance
55	OFDM	orthogonal Frequency Division Multiplexing
	PBCH	Physical Broadcast CHannel
	PCC	Primary Component Carrier
	PCCH	Paging Control CHannel

## EP 3 716 698 A1

	PCell	Primary Cell
	PCH	Paging CHannel
	PDCCH	Physical Downlink Control CHannel
	PDCP	Packet Data Convergence Protocol
5	PDSCH	Physical Downlink Shared CHannel
	PDU	Protocol Data Unit
	PHICH	Physical HARQ Indicator CHannel
	PHY	PHYSical
	PLMN	Public Land Mobile Network
10	PMI	Precoding Matrix Indicator
	PRACH	Physical Random Access CHannel
	PRB	Physical Resource Block
	SPCell	Primary Secondary Cell
	PSS	Primary Synchronization Signal
15	pTAG	primary Timing Advance Group
	PT-RS	Phase Tracking Reference Signal
	PUCCH	Physical Uplink Control CHannel
	PUSCH	Physical Uplink Shared CHannel
	QAM	Quadrature Amplitude Modulation
20	QFI	Quality of Service Indicator
	QoS	Quality of Service
	QPSK	Quadrature Phase Shift Keying
	RA	Random Access
	RACH	Random Access CHannel
25	RAN	Radio Access Network
	RAT	Radio Access Technology
	RA-RNTI	Random Access-Radio Network Temporary Identifier
	RB	Resource Blocks
	RBG	Resource Block Groups
30	RI	Rank indicator
	RLC	Radio Link Control
	RLM	Radio Link Monitoring
	RNTI	Radio Network Temporary Identifier
	RRC	Radio Resource Control
35	RRM	Radio Resource Management
	RS	Reference Signal
	RSRP	Reference Signal Received Power
	SCC	Secondary Component Carrier
	SCell	Secondary Cell
40	SCG	Secondary Cell Group
	SC-FDMA	Single Carrier-Frequency Division Multiple Access
	SDAP	Service Data Adaptation Protocol
	SDU	Service Data Unit
	SeNB	Secondary evolved Node B
45	SFN	System Frame Number
	S-GW	Serving GateWay
	SI	System Information
	SIB	System Information Block
	SMF	Session Management Function
50	SN	Secondary Node
	SpCell	Special Cell
	SRB	Signaling Radio Bearer
	SRS	Sounding Reference Signal
	SS	Synchronization Signal
55	SSS	Secondary Synchronization Signal
	sTAG	secondary Timing Advance Group
	TA	Timing Advance
	TAG	Timing Advance Group

TAI	Tracking Area Identifier
TAT	Time Alignment Timer
TB	Transport Block
TCI	Transmission Configuration Indication
5 TC-RNTI	Temporary Cell-Radio Network Temporary Identifier
TDD	Time Division Duplex
TDMA	Time Division Multiple Access
TRP	Transmission Reception Point
TTI	Transmission Time Interval
10 UCI	Uplink Control Information
UE	User Equipment
UL	Uplink
UL-SCH	Uplink Shared CHannel
UPF	User Plane Function
15 UPGW	User Plane Gateway
VHDL	VHSIC Hardware Description Language
Xn-C	Xn-Control plane
Xn-U	Xn-User plane

20 **[0005]** Example embodiments of the disclosure may be implemented using various physical layer modulation and transmission mechanisms. Example transmission mechanisms may include, but not limited to: Code Division Multiple Access (CDMA), Orthogonal Frequency Division Multiple Access (OFDMA), Time Division Multiple Access (TDMA), Wavelet technologies, and/or the like. Hybrid transmission mechanisms such as TDMA/CDMA, and OFDM/CDMA may also be employed. Various modulation schemes may be applied for signal transmission in the physical layer. Examples of modulation schemes include, but are not limited to: phase, amplitude, code, a combination of these, and/or the like. An example radio transmission method may implement Quadrature Amplitude Modulation (QAM) using pi-over-two Binary Phase Shift Keying ( $\pi/2$ -BPSK), Binary Phase Shift Keying (BPSK), Quadrature Phase Shift Keying (QPSK), 16-QAM, 64-QAM, 256-QAM, 1024-QAM, and/or the like. Physical radio transmission may be enhanced by dynamically or semi-dynamically changing the modulation and coding scheme depending on transmission requirements and radio conditions.

25 **[0006]** FIG. 1 is an example Radio Access Network (RAN) architecture as per an aspect of an embodiment of the present disclosure. As illustrated in this example, a RAN node may be a next generation Node B (gNB) (e.g. 120A, 120B) providing New Radio (NR) user plane and control plane protocol terminations towards a first wireless device (e.g. 110A). In an example, a RAN node may be a next generation evolved Node B (ng-eNB) (e.g. 120C, 120D), providing Evolved UMTS Terrestrial Radio Access (E-UTRA) user plane and control plane protocol terminations towards a second wireless device (e.g. 110B). The first wireless device may communicate with a gNB over a Uu interface. The second wireless device may communicate with a ng-eNB over a Uu interface.

30 **[0007]** A gNB or an ng-eNB may host functions such as radio resource management and scheduling, IP header compression, encryption and integrity protection of data, selection of Access and Mobility Management Function (AMF) at User Equipment (UE) attachment, routing of user plane and control plane data, connection setup and release, scheduling and transmission of paging messages (originated from the AMF), scheduling and transmission of system broadcast information (originated from the AMF or Operation and Maintenance (O&M)), measurement and measurement reporting configuration, transport level packet marking in the uplink, session management, support of network slicing, Quality of Service (QoS) flow management and mapping to data radio bearers, support of UEs in RRC\_INACTIVE state, distribution function for Non-Access Stratum (NAS) messages, RAN sharing, dual connectivity or tight interworking between NR and E-UTRA.

35 **[0008]** In an example, one or more gNBs and/or one or more ng-eNBs may be interconnected with each other by means of Xn interface. A gNB or an ng-eNB may be connected by means of NG interfaces to 5G Core Network (5GC). In an example, 5GC may comprise one or more AMF/User Plane Function (UPF) functions (e.g. 130A or 130B). A gNB or an ng-eNB may be connected to a UPF by means of an NG-User plane (NG-U) interface. The NG-U interface may provide delivery (e.g. non-guaranteed delivery) of user plane Protocol Data Units (PDUs) between a RAN node and the UPF. A gNB or an ng-eNB may be connected to an AMF by means of an NG-Control plane (NG-C) interface. The NG-C interface may provide functions such as NG interface management, UE context management, UE mobility management, transport of NAS messages, paging, PDU session management, configuration transfer or warning message transmission.

40 **[0009]** In an example, a UPF may host functions such as anchor point for intra-/inter-Radio Access Technology (RAT) mobility (when applicable), external PDU session point of interconnect to data network, packet routing and forwarding, packet inspection and user plane part of policy rule enforcement, traffic usage reporting, uplink classifier to support

routing traffic flows to a data network, branching point to support multi-homed PDU session, QoS handling for user plane, e.g. packet filtering, gating, Uplink (UL)/Downlink (DL) rate enforcement, uplink traffic verification (e.g. Service Data Flow (SDF) to QoS flow mapping), downlink packet buffering and/or downlink data notification triggering.

**[0010]** In an example, an AMF may host functions such as NAS signaling termination, NAS signaling security, Access Stratum (AS) security control, inter Core Network (CN) node signaling for mobility between 3<sup>rd</sup> Generation Partnership Project (3GPP) access networks, idle mode UE reachability (e.g., control and execution of paging retransmission), registration area management, support of intra-system and inter-system mobility, access authentication, access authorization including check of roaming rights, mobility management control (subscription and policies), support of network slicing and/or Session Management Function (SMF) selection.

**[0011]** FIG. 2A is an example user plane protocol stack, where Service Data Adaptation Protocol (SDAP) (e.g. 211 and 221), Packet Data Convergence Protocol (PDCP) (e.g. 212 and 222), Radio Link Control (RLC) (e.g. 213 and 223) and Media Access Control (MAC) (e.g. 214 and 224) sublayers and Physical (PHY) (e.g. 215 and 225) layer may be terminated in wireless device (e.g. 110) and gNB (e.g. 120) on the network side. In an example, a PHY layer provides transport services to higher layers (e.g. MAC, RRC, etc). In an example, services and functions of a MAC sublayer may comprise mapping between logical channels and transport channels, multiplexing/demultiplexing of MAC Service Data Units (SDUs) belonging to one or different logical channels into/from Transport Blocks (TBs) delivered to/from the PHY layer, scheduling information reporting, error correction through Hybrid Automatic Repeat request (HARQ) (e.g. one HARQ entity per carrier in case of Carrier Aggregation (CA)), priority handling between UEs by means of dynamic scheduling, priority handling between logical channels of one UE by means of logical channel prioritization, and/or padding. A MAC entity may support one or multiple numerologies and/or transmission timings. In an example, mapping restrictions in a logical channel prioritization may control which numerology and/or transmission timing a logical channel may use. In an example, an RLC sublayer may support transparent mode (TM), unacknowledged mode (UM) and acknowledged mode (AM) transmission modes. The RLC configuration may be per logical channel with no dependency on numerologies and/or Transmission Time Interval (TTI) durations. In an example, Automatic Repeat Request (ARQ) may operate on any of the numerologies and/or TTI durations the logical channel is configured with. In an example, services and functions of the PDCP layer for the user plane may comprise sequence numbering, header compression and decompression, transfer of user data, reordering and duplicate detection, PDCP PDU routing (e.g. in case of split bearers), retransmission of PDCP SDUs, ciphering, deciphering and integrity protection, PDCP SDU discard, PDCP re-establishment and data recovery for RLC AM, and/or duplication of PDCP PDUs. In an example, services and functions of SDAP may comprise mapping between a QoS flow and a data radio bearer. In an example, services and functions of SDAP may comprise mapping Quality of Service Indicator (QFI) in DL and UL packets. In an example, a protocol entity of SDAP may be configured for an individual PDU session.

**[0012]** FIG. 2B is an example control plane protocol stack where PDCP (e.g. 233 and 242), RLC (e.g. 234 and 243) and MAC (e.g. 235 and 244) sublayers and PHY (e.g. 236 and 245) layer may be terminated in wireless device (e.g. 110) and gNB (e.g. 120) on a network side and perform service and functions described above. In an example, RRC (e.g. 232 and 241) may be terminated in a wireless device and a gNB on a network side. Note that the same control plane protocol stack is considered between a wireless device and ng-eNB. In an example, services and functions of RRC may comprise broadcast of system information related to AS and NAS, paging initiated by 5GC or RAN, establishment, maintenance and release of an RRC connection between the UE and RAN, security functions including key management, establishment, configuration, maintenance and release of Signaling Radio Bearers (SRBs) and Data Radio Bearers (DRBs), mobility functions, QoS management functions, UE measurement reporting and control of the reporting, detection of and recovery from radio link failure, and/or NAS message transfer to/from NAS from/to a UE. In an example, NAS control protocol (e.g. 231 and 251) may be terminated in the wireless device and AMF (e.g. 130) on a network side and may perform functions such as authentication, mobility management between a UE and a AMF for 3GPP access and non-3GPP access, and session management between a UE and a SMF for 3GPP access and non-3GPP access.

**[0013]** In an example, a base station may configure a plurality of logical channels for a wireless device. A logical channel in the plurality of logical channels may correspond to a radio bearer and the radio bearer may be associated with a QoS requirement. In an example, a base station may configure a logical channel to be mapped to one or more TTIs/numerologies in a plurality of TTIs/numerologies. The wireless device may receive a Downlink Control Information (DCI) via Physical Downlink Control Channel (PDCCH) indicating an uplink grant. In an example, the uplink grant may be for a first TTI/numerology and may indicate uplink resources for transmission of a transport block. The base station may configure each logical channel in the plurality of logical channels with one or more parameters to be used by a logical channel prioritization procedure at the MAC layer of the wireless device. The one or more parameters may comprise priority, prioritized bit rate, etc. A logical channel in the plurality of logical channels may correspond to one or more buffers comprising data associated with the logical channel. The logical channel prioritization procedure may allocate the uplink resources to one or more first logical channels in the plurality of logical channels and/or one or more MAC Control Elements (CEs). The one or more first logical channels may be mapped to the first TTI/numerology. The

MAC layer at the wireless device may multiplex one or more MAC CEs and/or one or more MAC SDUs (e.g., logical channel) in a MAC PDU (e.g., transport block). In an example, the MAC PDU may comprise a MAC header comprising a plurality of MAC sub-headers. A MAC sub-header in the plurality of MAC sub-headers may correspond to a MAC CE or a MAC SUD (logical channel) in the one or more MAC CEs and/or one or more MAC SDUs. In an example, a MAC CE or a logical channel may be configured with a Logical Channel Identifier (LCID). In an example, LCID for a logical channel or a MAC CE may be fixed/pre-configured. In an example, LCID for a logical channel or MAC CE may be configured for the wireless device by the base station. The MAC sub-header corresponding to a MAC CE or a MAC SDU may comprise LCID associated with the MAC CE or the MAC SDU.

**[0014]** In an example, a base station may activate and/or deactivate and/or impact one or more processes (e.g., set values of one or more parameters of the one or more processes or start and/or stop one or more timers of the one or more processes) at the wireless device by employing one or more MAC commands. The one or more MAC commands may comprise one or more MAC control elements. In an example, the one or more processes may comprise activation and/or deactivation of PDCP packet duplication for one or more radio bearers. The base station may transmit a MAC CE comprising one or more fields, the values of the fields indicating activation and/or deactivation of PDCP duplication for the one or more radio bearers. In an example, the one or more processes may comprise Channel State Information (CSI) transmission of on one or more cells. The base station may transmit one or more MAC CEs indicating activation and/or deactivation of the CSI transmission on the one or more cells. In an example, the one or more processes may comprise activation or deactivation of one or more secondary cells. In an example, the base station may transmit a MA CE indicating activation or deactivation of one or more secondary cells. In an example, the base station may transmit one or more MAC CEs indicating starting and/or stopping one or more Discontinuous Reception (DRX) timers at the wireless device. In an example, the base station may transmit one or more MAC CEs indicating one or more timing advance values for one or more Timing Advance Groups (TAGs).

**[0015]** FIG. 3 is a block diagram of base stations (base station 1, 120A, and base station 2, 120B) and a wireless device 110. A wireless device may be called a UE. A base station may be called a NB, eNB, gNB, and/or ng-eNB. In an example, a wireless device and/or a base station may act as a relay node. The base station 1, 120A, may comprise at least one communication interface 320A (e.g. a wireless modem, an antenna, a wired modem, and/or the like), at least one processor 321A, and at least one set of program code instructions 323A stored in non-transitory memory 322A and executable by the at least one processor 321A. The base station 2, 120B, may comprise at least one communication interface 320B, at least one processor 321B, and at least one set of program code instructions 323B stored in non-transitory memory 322B and executable by the at least one processor 321B.

**[0016]** A base station may comprise many sectors for example: 1, 2, 3, 4, or 6 sectors. A base station may comprise many cells, for example, ranging from 1 to 50 cells or more. A cell may be categorized, for example, as a primary cell or secondary cell. At Radio Resource Control (RRC) connection establishment/re-establishment/handover, one serving cell may provide the NAS (non-access stratum) mobility information (e.g. Tracking Area Identifier (TAI)). At RRC connection re-establishment/handover, one serving cell may provide the security input. This cell may be referred to as the Primary Cell (PCell). In the downlink, a carrier corresponding to the PCell may be a DL Primary Component Carrier (PCC), while in the uplink, a carrier may be an UL PCC. Depending on wireless device capabilities, Secondary Cells (SCells) may be configured to form together with a PCell a set of serving cells. In a downlink, a carrier corresponding to an SCell may be a downlink secondary component carrier (DL SCC), while in an uplink, a carrier may be an uplink secondary component carrier (UL SCC). An SCell may or may not have an uplink carrier.

**[0017]** A cell, comprising a downlink carrier and optionally an uplink carrier, may be assigned a physical cell ID and a cell index. A carrier (downlink or uplink) may belong to one cell. The cell ID or cell index may also identify the downlink carrier or uplink carrier of the cell (depending on the context it is used). In the disclosure, a cell ID may be equally referred to a carrier ID, and a cell index may be referred to a carrier index. In an implementation, a physical cell ID or a cell index may be assigned to a cell. A cell ID may be determined using a synchronization signal transmitted on a downlink carrier. A cell index may be determined using RRC messages. For example, when the disclosure refers to a first physical cell ID for a first downlink carrier, the disclosure may mean the first physical cell ID is for a cell comprising the first downlink carrier. The same concept may apply to, for example, carrier activation. When the disclosure indicates that a first carrier is activated, the specification may equally mean that a cell comprising the first carrier is activated.

**[0018]** A base station may transmit to a wireless device one or more messages (e.g. RRC messages) comprising a plurality of configuration parameters for one or more cells. One or more cells may comprise at least one primary cell and at least one secondary cell. In an example, an RRC message may be broadcasted or unicasted to the wireless device. In an example, configuration parameters may comprise common parameters and dedicated parameters.

**[0019]** Services and/or functions of an RRC sublayer may comprise at least one of: broadcast of system information related to AS and NAS; paging initiated by 5GC and/or NG-RAN; establishment, maintenance, and/or release of an RRC connection between a wireless device and NG-RAN, which may comprise at least one of addition, modification and release of carrier aggregation; or addition, modification, and/or release of dual connectivity in NR or between E-UTRA and NR. Services and/or functions of an RRC sublayer may further comprise at least one of security functions comprising

key management; establishment, configuration, maintenance, and/or release of Signaling Radio Bearers (SRBs) and/or Data Radio Bearers (DRBs); mobility functions which may comprise at least one of a handover (e.g. intra NR mobility or inter-RAT mobility) and a context transfer; or a wireless device cell selection and reselection and control of cell selection and reselection. Services and/or functions of an RRC sublayer may further comprise at least one of QoS management functions; a wireless device measurement configuration/reporting; detection of and/or recovery from radio link failure; or NAS message transfer to/from a core network entity (e.g. AMF, Mobility Management Entity (MME)) from/to the wireless device.

**[0020]** An RRC sublayer may support an RRC\_Idle state, an RRC\_Inactive state and/or an RRC\_Connected state for a wireless device. In an RRC\_Idle state, a wireless device may perform at least one of: Public Land Mobile Network (PLMN) selection; receiving broadcasted system information; cell selection/re-selection; monitoring/receiving a paging for mobile terminated data initiated by 5GC; paging for mobile terminated data area managed by 5GC; or DRX for CN paging configured via NAS. In an RRC\_Inactive state, a wireless device may perform at least one of: receiving broadcasted system information; cell selection/re-selection; monitoring/receiving a RAN/CN paging initiated by NG-RAN/5GC; RAN-based notification area (RNA) managed by NG-RAN; or DRX for RAN/CN paging configured by NG-RAN/NAS. In an RRC\_Idle state of a wireless device, a base station (e.g. NG-RAN) may keep a 5GC-NG-RAN connection (both C/U-planes) for the wireless device; and/or store a UE AS context for the wireless device. In an RRC\_Connected state of a wireless device, a base station (e.g. NG-RAN) may perform at least one of: establishment of 5GC-NG-RAN connection (both C/U-planes) for the wireless device; storing a UE AS context for the wireless device; transmit/receive of unicast data to/from the wireless device; or network-controlled mobility based on measurement results received from the wireless device. In an RRC\_Connected state of a wireless device, an NG-RAN may know a cell that the wireless device belongs to.

**[0021]** System information (SI) may be divided into minimum SI and other SIs. The minimum SI may be periodically broadcast. The minimum SI may comprise basic information required for initial access and information for acquiring any other SI broadcast periodically or provisioned on-demand, e.g. scheduling information. The other SI may either be broadcast, or be provisioned in a dedicated manner, either triggered by a network or upon request from a wireless device. A minimum SI may be transmitted via two different downlink channels using different messages (e.g. *MasterInformationBlock* and *SystemInformationBlockType1*). Another SI may be transmitted via *SystemInformationBlockType2*. For a wireless device in an RRC\_Connected state, dedicated RRC signalling may be employed for the request and delivery of the other SI. For the wireless device in the RRC\_Idle state and/or the RRC\_Inactive state, the request may trigger a random-access procedure.

**[0022]** A wireless device may report its radio access capability information which may be static. A base station may request what capabilities for a wireless device to report based on band information. When allowed by a network, a temporary capability restriction request may be sent by the wireless device to signal the limited availability of some capabilities (e.g. due to hardware sharing, interference or overheating) to the base station. The base station may confirm or reject the request. The temporary capability restriction may be transparent to 5GC (e.g., static capabilities may be stored in 5GC).

**[0023]** When CA is configured, a wireless device may have an RRC connection with a network. At RRC connection establishment/re-establishment/handover procedure, one serving cell may provide NAS mobility information, and at RRC connection re-establishment/handover, one serving cell may provide a security input. This cell may be referred to as the PCell. Depending on the capabilities of the wireless device, SCells may be configured to form together with the PCell a set of serving cells. The configured set of serving cells for the wireless device may comprise one PCell and one or more SCells.

**[0024]** The reconfiguration, addition and removal of SCells may be performed by RRC. At intra-NR handover, RRC may also add, remove, or reconfigure SCells for usage with the target PCell. When adding a new SCell, dedicated RRC signalling may be employed to send all required system information of the SCell e.g. while in connected mode, wireless devices may not need to acquire broadcasted system information directly from the SCells.

**[0025]** The purpose of an RRC connection reconfiguration procedure may be to modify an RRC connection, (e.g. to establish, modify and/or release RBs, to perform handover, to setup, modify, and/or release measurements, to add, modify, and/or release SCells and cell groups). As part of the RRC connection reconfiguration procedure, NAS dedicated information may be transferred from the network to the wireless device. The *RRCConnectionReconfiguration* message may be a command to modify an RRC connection. It may convey information for measurement configuration, mobility control, radio resource configuration (e.g. RBs, MAC main configuration and physical channel configuration) comprising any associated dedicated NAS information and security configuration. If the received RRC Connection Reconfiguration message includes the *sCellToReleaseList*, the wireless device may perform an SCell release. If the received RRC Connection Reconfiguration message includes the *sCellToAddModList*, the wireless device may perform SCell additions or modification.

**[0026]** An RRC connection establishment (or reestablishment, resume) procedure may be to establish (or reestablish, resume) an RRC connection. an RRC connection establishment procedure may comprise SRB1 establishment. The RRC connection establishment procedure may be used to transfer the initial NAS dedicated information/ message from

a wireless device to E-UTRAN. The *RRConnectionReestablishment* message may be used to re-establish SRB1.

**[0027]** A measurement report procedure may be to transfer measurement results from a wireless device to NG-RAN. The wireless device may initiate a measurement report procedure after successful security activation. A measurement report message may be employed to transmit measurement results.

**[0028]** The wireless device 110 may comprise at least one communication interface 310 (e.g. a wireless modem, an antenna, and/or the like), at least one processor 314, and at least one set of program code instructions 316 stored in non-transitory memory 315 and executable by the at least one processor 314. The wireless device 110 may further comprise at least one of at least one speaker/microphone 311, at least one keypad 312, at least one display/touchpad 313, at least one power source 317, at least one global positioning system (GPS) chipset 318, and other peripherals 319.

**[0029]** The processor 314 of the wireless device 110, the processor 321A of the base station 1 120A, and/or the processor 321B of the base station 2 120B may comprise at least one of a general-purpose processor, a digital signal processor (DSP), a controller, a microcontroller, an application specific integrated circuit (ASIC), a field programmable gate array (FPGA) and/or other programmable logic device, discrete gate and/or transistor logic, discrete hardware components, and the like. The processor 314 of the wireless device 110, the processor 321A in base station 1 120A, and/or the processor 321B in base station 2 120B may perform at least one of signal coding/processing, data processing, power control, input/output processing, and/or any other functionality that may enable the wireless device 110, the base station 1 120A and/or the base station 2 120B to operate in a wireless environment.

**[0030]** The processor 314 of the wireless device 110 may be connected to the speaker/microphone 311, the keypad 312, and/or the display/touchpad 313. The processor 314 may receive user input data from and/or provide user output data to the speaker/microphone 311, the keypad 312, and/or the display/touchpad 313. The processor 314 in the wireless device 110 may receive power from the power source 317 and/or may be configured to distribute the power to the other components in the wireless device 110. The power source 317 may comprise at least one of one or more dry cell batteries, solar cells, fuel cells, and the like. The processor 314 may be connected to the GPS chipset 318. The GPS chipset 318 may be configured to provide geographic location information of the wireless device 110.

**[0031]** The processor 314 of the wireless device 110 may further be connected to other peripherals 319, which may comprise one or more software and/or hardware modules that provide additional features and/or functionalities. For example, the peripherals 319 may comprise at least one of an accelerometer, a satellite transceiver, a digital camera, a universal serial bus (USB) port, a hands-free headset, a frequency modulated (FM) radio unit, a media player, an Internet browser, and the like.

**[0032]** The communication interface 320A of the base station 1, 120A, and/or the communication interface 320B of the base station 2, 120B, may be configured to communicate with the communication interface 310 of the wireless device 110 via a wireless link 330A and/or a wireless link 330B respectively. In an example, the communication interface 320A of the base station 1, 120A, may communicate with the communication interface 320B of the base station 2 and other RAN and core network nodes.

**[0033]** The wireless link 330A and/or the wireless link 330B may comprise at least one of a bidirectional link and/or a directional link. The communication interface 310 of the wireless device 110 may be configured to communicate with the communication interface 320A of the base station 1 120A and/or with the communication interface 320B of the base station 2 120B. The base station 1 120A and the wireless device 110 and/or the base station 2 120B and the wireless device 110 may be configured to send and receive transport blocks via the wireless link 330A and/or via the wireless link 330B, respectively. The wireless link 330A and/or the wireless link 330B may employ at least one frequency carrier. According to some of various aspects of embodiments, transceiver(s) may be employed. A transceiver may be a device that comprises both a transmitter and a receiver. Transceivers may be employed in devices such as wireless devices, base stations, relay nodes, and/or the like. Example embodiments for radio technology implemented in the communication interface 310, 320A, 320B and the wireless link 330A, 330B are illustrated in FIG. 4A, FIG. 4B, FIG. 4C, FIG. 4D, FIG. 6, FIG. 7A, FIG. 7B, FIG. 8, and associated text.

**[0034]** In an example, other nodes in a wireless network (e.g. AMF, UPF, SMF, etc) may comprise one or more communication interfaces, one or more processors, and memory storing instructions.

**[0035]** A node (e.g. wireless device, base station, AMF, SMF, UPF, servers, switches, antennas, and/or the like) may comprise one or more processors, and memory storing instructions that when executed by the one or more processors causes the node to perform certain processes and/or functions. Example embodiments may enable operation of single-carrier and/or multi-carrier communications. Other example embodiments may comprise a non-transitory tangible computer readable media comprising instructions executable by one or more processors to cause operation of single-carrier and/or multi-carrier communications. Yet other example embodiments may comprise an article of manufacture that comprises a non-transitory tangible computer readable machine-accessible medium having instructions encoded thereon for enabling programmable hardware to cause a node to enable operation of single-carrier and/or multi-carrier communications. The node may include processors, memory, interfaces, and/or the like.

**[0036]** An interface may comprise at least one of a hardware interface, a firmware interface, a software interface, and/or a combination thereof. The hardware interface may comprise connectors, wires, electronic devices such as

drivers, amplifiers, and/or the like. The software interface may comprise code stored in a memory device to implement protocol(s), protocol layers, communication drivers, device drivers, combinations thereof, and/or the like. The firmware interface may comprise a combination of embedded hardware and code stored in and/or in communication with a memory device to implement connections, electronic device operations, protocol(s), protocol layers, communication drivers,

5 device drivers, hardware operations, combinations thereof, and/or the like.  
**[0037]** FIG. 4A, FIG. 4B, FIG. 4C and FIG. 4D are example diagrams for uplink and downlink signal transmission as per an aspect of an embodiment of the present disclosure. FIG. 4A shows an example uplink transmitter for at least one physical channel. A baseband signal representing a physical uplink shared channel may perform one or more functions. The one or more functions may comprise at least one of: scrambling; modulation of scrambled bits to generate complex-valued symbols; mapping of the complex-valued modulation symbols onto one or several transmission layers; transform precoding to generate complex-valued symbols; precoding of the complex-valued symbols; mapping of precoded complex-valued symbols to resource elements; generation of complex-valued time-domain Single Carrier-Frequency Division Multiple Access (SC-FDMA) or CP-OFDM signal for an antenna port; and/or the like. In an example, when transform precoding is enabled, a SC-FDMA signal for uplink transmission may be generated. In an example, when transform precoding is not enabled, an CP-OFDM signal for uplink transmission may be generated by FIG. 4A. These functions are illustrated as examples and it is anticipated that other mechanisms may be implemented in various embodiments.

10 **[0038]** An example structure for modulation and up-conversion to the carrier frequency of the complex-valued SC-FDMA or CP-OFDM baseband signal for an antenna port and/or the complex-valued Physical Random Access CHannel (PRACH) baseband signal is shown in FIG. 4B. Filtering may be employed prior to transmission.

20 **[0039]** An example structure for downlink transmissions is shown in FIG. 4C. The baseband signal representing a downlink physical channel may perform one or more functions. The one or more functions may comprise: scrambling of coded bits in a codeword to be transmitted on a physical channel; modulation of scrambled bits to generate complex-valued modulation symbols; mapping of the complex-valued modulation symbols onto one or several transmission layers; precoding of the complex-valued modulation symbols on a layer for transmission on the antenna ports; mapping of complex-valued modulation symbols for an antenna port to resource elements; generation of complex-valued time-domain OFDM signal for an antenna port; and/or the like. These functions are illustrated as examples and it is anticipated that other mechanisms may be implemented in various embodiments.

25 **[0040]** In an example, a gNB may transmit a first symbol and a second symbol on an antenna port, to a wireless device. The wireless device may infer the channel (e.g., fading gain, multipath delay, etc.) for conveying the second symbol on the antenna port, from the channel for conveying the first symbol on the antenna port. In an example, a first antenna port and a second antenna port may be quasi co-located if one or more large-scale properties of the channel over which a first symbol on the first antenna port is conveyed may be inferred from the channel over which a second symbol on a second antenna port is conveyed. The one or more large-scale properties may comprise at least one of: delay spread; doppler spread; doppler shift; average gain; average delay; and/or spatial Receiving (Rx) parameters.

30 **[0041]** An example modulation and up-conversion to the carrier frequency of the complex-valued OFDM baseband signal for an antenna port is shown in FIG. 4D. Filtering may be employed prior to transmission.

35 **[0042]** FIG. 5A is a diagram of an example uplink channel mapping and example uplink physical signals. FIG. 5B is a diagram of an example downlink channel mapping and a downlink physical signals. In an example, a physical layer may provide one or more information transfer services to a MAC and/or one or more higher layers. For example, the physical layer may provide the one or more information transfer services to the MAC via one or more transport channels. An information transfer service may indicate how and with what characteristics data are transferred over the radio interface.

40 **[0043]** In an example embodiment, a radio network may comprise one or more downlink and/or uplink transport channels. For example, a diagram in FIG. 5A shows example uplink transport channels comprising Uplink-Shared CHannel (UL-SCH) 501 and Random Access CHannel (RACH) 502. A diagram in FIG. 5B shows example downlink transport channels comprising Downlink-Shared CHannel (DL-SCH) 511, Paging CHannel (PCH) 512, and Broadcast CHannel (BCH) 513. A transport channel may be mapped to one or more corresponding physical channels. For example, UL-SCH 501 may be mapped to Physical Uplink Shared CHannel (PUSCH) 503. RACH 502 may be mapped to PRACH 505. DL-SCH 511 and PCH 512 may be mapped to Physical Downlink Shared CHannel (PDSCH) 514. BCH 513 may be mapped to Physical Broadcast CHannel (PBCH) 516.

45 **[0044]** There may be one or more physical channels without a corresponding transport channel. The one or more physical channels may be employed for Uplink Control Information (UCI) 509 and/or Downlink Control Information (DCI) 517. For example, Physical Uplink Control CHannel (PUCCH) 504 may carry UCI 509 from a UE to a base station. For example, Physical Downlink Control CHannel (PDCCH) 515 may carry DCI 517 from a base station to a UE. NR may support UCI 509 multiplexing in PUSCH 503 when UCI 509 and PUSCH 503 transmissions may coincide in a slot at least in part. The UCI 509 may comprise at least one of CSI, Acknowledgement (ACK)/Negative Acknowledgement (NACK), and/or scheduling request. The DCI 517 on PDCCH 515 may indicate at least one of following: one or more downlink assignments and/or one or more uplink scheduling grants

**[0045]** In uplink, a UE may transmit one or more Reference Signals (RSs) to a base station. For example, the one or more RSs may be at least one of Demodulation-RS (DM-RS) 506, Phase Tracking-RS (PT-RS) 507, and/or Sounding RS (SRS) 508. In downlink, a base station may transmit (e.g., unicast, multicast, and/or broadcast) one or more RSs to a UE. For example, the one or more RSs may be at least one of Primary Synchronization Signal (PSS)/Secondary Synchronization Signal (SSS) 521, CSI-RS 522, DM-RS 523, and/or PT-RS 524.

**[0046]** In an example, a UE may transmit one or more uplink DM-RSs 506 to a base station for channel estimation, for example, for coherent demodulation of one or more uplink physical channels (e.g., PUSCH 503 and/or PUCCH 504). For example, a UE may transmit a base station at least one uplink DM-RS 506 with PUSCH 503 and/or PUCCH 504, wherein the at least one uplink DM-RS 506 may be spanning a same frequency range as a corresponding physical channel. In an example, a base station may configure a UE with one or more uplink DM-RS configurations. At least one DM-RS configuration may support a front-loaded DM-RS pattern. A front-loaded DM-RS may be mapped over one or more OFDM symbols (e.g., 1 or 2 adjacent OFDM symbols). One or more additional uplink DM-RS may be configured to transmit at one or more symbols of a PUSCH and/or PUCCH. A base station may semi-statistically configure a UE with a maximum number of front-loaded DM-RS symbols for PUSCH and/or PUCCH. For example, a UE may schedule a single-symbol DM-RS and/or double symbol DM-RS based on a maximum number of front-loaded DM-RS symbols, wherein a base station may configure the UE with one or more additional uplink DM-RS for PUSCH and/or PUCCH. A new radio network may support, e.g., at least for CP-OFDM, a common DM-RS structure for DL and UL, wherein a DM-RS location, DM-RS pattern, and/or scrambling sequence may be same or different.

**[0047]** In an example, whether uplink PT-RS 507 is present or not may depend on a RRC configuration. For example, a presence of uplink PT-RS may be UE-specifically configured. For example, a presence and/or a pattern of uplink PT-RS 507 in a scheduled resource may be UE-specifically configured by a combination of RRC signaling and/or association with one or more parameters employed for other purposes (e.g., Modulation and Coding Scheme (MCS)) which may be indicated by DCI. When configured, a dynamic presence of uplink PT-RS 507 may be associated with one or more DCI parameters comprising at least MCS. A radio network may support plurality of uplink PT-RS densities defined in time/frequency domain. When present, a frequency domain density may be associated with at least one configuration of a scheduled bandwidth. A UE may assume a same precoding for a DMRS port and a PT-RS port. A number of PT-RS ports may be fewer than a number of DM-RS ports in a scheduled resource. For example, uplink PT-RS 507 may be confined in the scheduled time/frequency duration for a UE.

**[0048]** In an example, a UE may transmit SRS 508 to a base station for channel state estimation to support uplink channel dependent scheduling and/or link adaptation. For example, SRS 508 transmitted by a UE may allow for a base station to estimate an uplink channel state at one or more different frequencies. A base station scheduler may employ an uplink channel state to assign one or more resource blocks of good quality for an uplink PUSCH transmission from a UE. A base station may semi-statistically configure a UE with one or more SRS resource sets. For an SRS resource set, a base station may configure a UE with one or more SRS resources. An SRS resource set applicability may be configured by a higher layer (e.g., RRC) parameter. For example, when a higher layer parameter indicates beam management, a SRS resource in each of one or more SRS resource sets may be transmitted at a time instant. A UE may transmit one or more SRS resources in different SRS resource sets simultaneously. A new radio network may support aperiodic, periodic and/or semi-persistent SRS transmissions. A UE may transmit SRS resources based on one or more trigger types, wherein the one or more trigger types may comprise higher layer signaling (e.g., RRC) and/or one or more DCI formats (e.g., at least one DCI format may be employed for a UE to select at least one of one or more configured SRS resource sets. An SRS trigger type 0 may refer to an SRS triggered based on a higher layer signaling. An SRS trigger type 1 may refer to an SRS triggered based on one or more DCI formats. In an example, when PUSCH 503 and SRS 508 are transmitted in a same slot, a UE may be configured to transmit SRS 508 after a transmission of PUSCH 503 and corresponding uplink DM-RS 506.

**[0049]** In an example, a base station may semi-statistically configure a UE with one or more SRS configuration parameters indicating at least one of following: a SRS resource configuration identifier, a number of SRS ports, time domain behavior of SRS resource configuration (e.g., an indication of periodic, semi-persistent, or aperiodic SRS), slot (mini-slot, and/or subframe) level periodicity and/or offset for a periodic and/or aperiodic SRS resource, a number of OFDM symbols in a SRS resource, starting OFDM symbol of a SRS resource, a SRS bandwidth, a frequency hopping bandwidth, a cyclic shift, and/or a SRS sequence ID.

**[0050]** In an example, in a time domain, an SS/PBCH block may comprise one or more OFDM symbols (e.g., 4 OFDM symbols numbered in increasing order from 0 to 3) within the SS/PBCH block. An SS/PBCH block may comprise PSS/SSS 521 and PBCH 516. In an example, in the frequency domain, an SS/PBCH block may comprise one or more contiguous subcarriers (e.g., 240 contiguous subcarriers with the subcarriers numbered in increasing order from 0 to 239) within the SS/PBCH block. For example, a PSS/SSS 521 may occupy 1 OFDM symbol and 127 subcarriers. For example, PBCH 516 may span across 3 OFDM symbols and 240 subcarriers. A UE may assume that one or more SS/PBCH blocks transmitted with a same block index may be quasi co-located, e.g., with respect to Doppler spread, Doppler shift, average gain, average delay, and spatial Rx parameters. A UE may not assume quasi co-location for other SS/PBCH

block transmissions. A periodicity of an SS/PBCH block may be configured by a radio network (e.g., by an RRC signaling) and one or more time locations where the SS/PBCH block may be sent may be determined by sub-carrier spacing. In an example, a UE may assume a band-specific sub-carrier spacing for an SS/PBCH block unless a radio network has configured a UE to assume a different sub-carrier spacing.

**[0051]** In an example, downlink CSI-RS 522 may be employed for a UE to acquire channel state information. A radio network may support periodic, aperiodic, and/or semi-persistent transmission of downlink CSI-RS 522. For example, a base station may semi-statistically configure and/or reconfigure a UE with periodic transmission of downlink CSI-RS 522. A configured CSI-RS resources may be activated and/or deactivated. For semi-persistent transmission, an activation and/or deactivation of CSI-RS resource may be triggered dynamically. In an example, CSI-RS configuration may comprise one or more parameters indicating at least a number of antenna ports. For example, a base station may configure a UE with 32 ports. A base station may semi-statistically configure a UE with one or more CSI-RS resource sets. One or more CSI-RS resources may be allocated from one or more CSI-RS resource sets to one or more UEs. For example, a base station may semi-statistically configure one or more parameters indicating CSI-RS resource mapping, for example, time-domain location of one or more CSI-RS resources, a bandwidth of a CSI-RS resource, and/or a periodicity. In an example, a UE may be configured to employ a same OFDM symbols for downlink CSI-RS 522 and control resource set (coreset) when the downlink CSI-RS 522 and coreset are spatially quasi co-located and resource elements associated with the downlink CSI-RS 522 are the outside of PRBs configured for coreset. In an example, a UE may be configured to employ a same OFDM symbols for downlink CSI-RS 522 and SS/PBCH blocks when the downlink CSI-RS 522 and SS/PBCH blocks are spatially quasi co-located and resource elements associated with the downlink CSI-RS 522 are the outside of PRBs configured for SS/PBCH blocks.

**[0052]** In an example, a UE may transmit one or more downlink DM-RSs 523 to a base station for channel estimation, for example, for coherent demodulation of one or more downlink physical channels (e.g., PDSCH 514). For example, a radio network may support one or more variable and/or configurable DM-RS patterns for data demodulation. At least one downlink DM-RS configuration may support a front-loaded DM-RS pattern. A front-loaded DM-RS may be mapped over one or more OFDM symbols (e.g., 1 or 2 adjacent OFDM symbols). A base station may semi-statistically configure a UE with a maximum number of front-loaded DM-RS symbols for PDSCH 514. For example, a DM-RS configuration may support one or more DM-RS ports. For example, for single user-MIMO, a DM-RS configuration may support at least 8 orthogonal downlink DM-RS ports. For example, for multiuser-MIMO, a DM-RS configuration may support 12 orthogonal downlink DM-RS ports. A radio network may support, e.g., at least for CP-OFDM, a common DM-RS structure for DL and UL, wherein a DM-RS location, DM-RS pattern, and/or scrambling sequence may be same or different.

**[0053]** In an example, whether downlink PT-RS 524 is present or not may depend on a RRC configuration. For example, a presence of downlink PT-RS 524 may be UE-specifically configured. For example, a presence and/or a pattern of downlink PT-RS 524 in a scheduled resource may be UE-specifically configured by a combination of RRC signaling and/or association with one or more parameters employed for other purposes (e.g., MCS) which may be indicated by DCI. When configured, a dynamic presence of downlink PT-RS 524 may be associated with one or more DCI parameters comprising at least MCS. A radio network may support plurality of PT-RS densities defined in time/frequency domain. When present, a frequency domain density may be associated with at least one configuration of a scheduled bandwidth. A UE may assume a same precoding for a DM-RS port and a PT-RS port. A number of PT-RS ports may be fewer than a number of DM-RS ports in a scheduled resource. For example, downlink PT-RS 524 may be confined in the scheduled time/frequency duration for a UE.

**[0054]** FIG. 6 is a diagram depicting an example transmission time and reception time for a carrier as per an aspect of an embodiment of the present disclosure. A multicarrier OFDM communication system may include one or more carriers, for example, ranging from 1 to 32 carriers, in case of carrier aggregation, or ranging from 1 to 64 carriers, in case of dual connectivity. Different radio frame structures may be supported (e.g., for FDD and for TDD duplex mechanisms). FIG. 6 shows an example frame timing. Downlink and uplink transmissions may be organized into radio frames 601. In this example, radio frame duration is 10 ms. In this example, a 10 ms radio frame 601 may be divided into ten equally sized subframes 602 with 1 ms duration. Subframe(s) may comprise one or more slots (e.g. slots 603 and 605) depending on subcarrier spacing and/or CP length. For example, a subframe with 15 kHz, 30 kHz, 60 kHz, 120 kHz, 240 kHz and 480 kHz subcarrier spacing may comprise one, two, four, eight, sixteen and thirty-two slots, respectively. In FIG. 6, a subframe may be divided into two equally sized slots 603 with 0.5 ms duration. For example, 10 subframes may be available for downlink transmission and 10 subframes may be available for uplink transmissions in a 10 ms interval. Uplink and downlink transmissions may be separated in the frequency domain. Slot(s) may include a plurality of OFDM symbols 604. The number of OFDM symbols 604 in a slot 605 may depend on the cyclic prefix length. For example, a slot may be 14 OFDM symbols for the same subcarrier spacing of up to 480 kHz with normal CP. A slot may be 12 OFDM symbols for the same subcarrier spacing of 60kHz with extended CP. A slot may contain downlink, uplink, or a downlink part and an uplink part and/or alike.

**[0055]** FIG. 7A is a diagram depicting example sets of OFDM subcarriers as per an aspect of an embodiment of the present disclosure. In the example, a gNB may communicate with a wireless device with a carrier with an example

channel bandwidth 700. Arrow(s) in the diagram may depict a subcarrier in a multicarrier OFDM system. The OFDM system may use technology such as OFDM technology, SC-FDMA technology, and/or the like. In an example, an arrow 701 shows a subcarrier transmitting information symbols. In an example, a subcarrier spacing 702, between two contiguous subcarriers in a carrier, may be any one of 15KHz, 30KHz, 60 KHz, 120KHz, 240KHz etc. In an example, different subcarrier spacing may correspond to different transmission numerologies. In an example, a transmission numerology may comprise at least: a numerology index; a value of subcarrier spacing; a type of cyclic prefix (CP). In an example, a gNB may transmit to/receive from a UE on a number of subcarriers 703 in a carrier. In an example, a bandwidth occupied by a number of subcarriers 703 (transmission bandwidth) may be smaller than the channel bandwidth 700 of a carrier, due to guard band 704 and 705. In an example, a guard band 704 and 705 may be used to reduce interference to and from one or more neighbor carriers. A number of subcarriers (transmission bandwidth) in a carrier may depend on the channel bandwidth of the carrier and the subcarrier spacing. For example, a transmission bandwidth, for a carrier with 20MHz channel bandwidth and 15KHz subcarrier spacing, may be in number of 1024 subcarriers.

**[0056]** In an example, a gNB and a wireless device may communicate with multiple CCs when configured with CA. In an example, different component carriers may have different bandwidth and/or subcarrier spacing, if CA is supported. In an example, a gNB may transmit a first type of service to a UE on a first component carrier. The gNB may transmit a second type of service to the UE on a second component carrier. Different type of services may have different service requirement (e.g., data rate, latency, reliability), which may be suitable for transmission via different component carrier having different subcarrier spacing and/or bandwidth. FIG. 7B shows an example embodiment. A first component carrier may comprise a first number of subcarriers 706 with a first subcarrier spacing 709. A second component carrier may comprise a second number of subcarriers 707 with a second subcarrier spacing 710. A third component carrier may comprise a third number of subcarriers 708 with a third subcarrier spacing 711. Carriers in a multicarrier OFDM communication system may be contiguous carriers, non-contiguous carriers, or a combination of both contiguous and non-contiguous carriers.

**[0057]** FIG. 8 is a diagram depicting OFDM radio resources as per an aspect of an embodiment of the present disclosure. In an example, a carrier may have a transmission bandwidth 801. In an example, a resource grid may be in a structure of frequency domain 802 and time domain 803. In an example, a resource grid may comprise a first number of OFDM symbols in a subframe and a second number of resource blocks, starting from a common resource block indicated by higher-layer signaling (e.g. RRC signaling), for a transmission numerology and a carrier. In an example, in a resource grid, a resource unit identified by a subcarrier index and a symbol index may be a resource element 805. In an example, a subframe may comprise a first number of OFDM symbols 807 depending on a numerology associated with a carrier. For example, when a subcarrier spacing of a numerology of a carrier is 15KHz, a subframe may have 14 OFDM symbols for a carrier. When a subcarrier spacing of a numerology is 30KHz, a subframe may have 28 OFDM symbols. When a subcarrier spacing of a numerology is 60KHz, a subframe may have 56 OFDM symbols, etc. In an example, a second number of resource blocks comprised in a resource grid of a carrier may depend on a bandwidth and a numerology of the carrier.

**[0058]** As shown in FIG. 8, a resource block 806 may comprise 12 subcarriers. In an example, multiple resource blocks may be grouped into a Resource Block Group (RBG) 804. In an example, a size of a RBG may depend on at least one of: a RRC message indicating a RBG size configuration; a size of a carrier bandwidth; and/or a size of a bandwidth part of a carrier. In an example, a carrier may comprise multiple bandwidth parts. A first bandwidth part of a carrier may have different frequency location and/or bandwidth from a second bandwidth part of the carrier. In an example, there is one or more of active bandwidth part among the configured bandwidth parts where a size of RBG may be determined based on one or more of active bandwidth part(s).

**[0059]** In an example, a gNB may transmit a downlink control information comprising a downlink or uplink resource block assignment to a wireless device or a set of commands. A base station may transmit to or receive from, a wireless device, data packets (e.g. transport blocks) scheduled and transmitted via one or more resource blocks and one or more slots according to parameters in a downlink control information and/or RRC message(s). In an example, a starting symbol relative to a first slot of the one or more slots may be indicated to the wireless device. In an example, a gNB may transmit to or receive from, a wireless device, data packets scheduled on one or more RBGs and one or more slots.

**[0060]** In an example, a gNB may transmit a downlink control information comprising a downlink assignment to a wireless device via one or more PDCCHs. The downlink assignment may comprise parameters indicating at least modulation and coding format; resource allocation; and/or HARQ information related to DL-SCH. In an example, a resource allocation may comprise parameters of resource block allocation; and/or slot allocation. In an example, a gNB may dynamically allocate resources to a wireless device via a Cell-Radio Network Temporary Identifier (C-RNTI) on one or more PDCCHs. The wireless device may monitor the one or more PDCCHs in order to find possible allocation when its downlink reception is enabled. The wireless device may receive one or more downlink data package on one or more PDSCH scheduled by the one or more PDCCHs, when successfully detecting the one or more PDCCHs.

**[0061]** In an example, a gNB may allocate Configured Scheduling (CS) resources for down link transmission to a wireless device. The gNB may transmit one or more RRC messages indicating a periodicity of the CS grant. The gNB

may transmit a DCI via a PDCCH addressed to a Configured Scheduling-RNTI (CS-RNTI) activating the CS resources. The DCI may comprise parameters indicating that the downlink grant is a CS grant. The CS grant may be implicitly reused according to the periodicity defined by the one or more RRC messages, until deactivated.

**[0062]** In an example, a gNB may transmit a downlink control information comprising an uplink grant to a wireless device via one or more PDCCHs. The uplink grant may comprise parameters indicating at least modulation and coding format; resource allocation; and/or HARQ information related to UL-SCH. In an example, a resource allocation may comprise parameters of resource block allocation; and/or slot allocation. In an example, a gNB may dynamically allocate resources to a wireless device via a C-RNTI on one or more PDCCHs. The wireless device may monitor the one or more PDCCHs in order to find possible resource allocation. The wireless device may transmit one or more uplink data package via one or more PUSCH scheduled by the one or more PDCCHs, when successfully detecting the one or more PDCCHs.

**[0063]** In an example, a gNB may allocate CS resources for uplink data transmission to a wireless device. The gNB may transmit one or more RRC messages indicating a periodicity of the CS grant. The gNB may transmit a DCI via a PDCCH addressed to a CS-RNTI activating the CS resources. The DCI may comprise parameters indicating that the uplink grant is a CS grant. The CS grant may be implicitly reused according to the periodicity defined by the one or more RRC message, until deactivated.

**[0064]** In an example, a base station may transmit DCI/control signaling via PDCCH. The DCI may take a format in a plurality of formats. A DCI may comprise downlink and/or uplink scheduling information (e.g., resource allocation information, HARQ related parameters, MCS), request for CSI (e.g., aperiodic CQI reports), request for SRS, uplink power control commands for one or more cells, one or more timing information (e.g., TB transmission/reception timing, HARQ feedback timing, etc.), etc. In an example, a DCI may indicate an uplink grant comprising transmission parameters for one or more transport blocks. In an example, a DCI may indicate downlink assignment indicating parameters for receiving one or more transport blocks. In an example, a DCI may be used by base station to initiate a contention-free random access at the wireless device. In an example, the base station may transmit a DCI comprising slot format indicator (SFI) notifying a slot format. In an example, the base station may transmit a DCI comprising pre-emption indication notifying the PRB(s) and/or OFDM symbol(s) where a UE may assume no transmission is intended for the UE. In an example, the base station may transmit a DCI for group power control of PUCCH or PUSCH or SRS. In an example, a DCI may correspond to an RNTI. In an example, the wireless device may obtain an RNTI in response to completing the initial access (e.g., C-RNTI). In an example, the base station may configure an RNTI for the wireless (e.g., CS-RNTI, TPC-CS-RNTI, TPC-PUCCH-RNTI, TPC-PUSCH-RNTI, TPC-SRS-RNTI). In an example, the wireless device may compute an RNTI (e.g., the wireless device may compute RA-RNTI based on resources used for transmission of a preamble). In an example, an RNTI may have a pre-configured value (e.g., P-RNTI or SI-RNTI). In an example, a wireless device may monitor a group common search space which may be used by base station for transmitting DCIs that are intended for a group of UEs. In an example, a group common DCI may correspond to an RNTI which is commonly configured for a group of UEs. In an example, a wireless device may monitor a UE-specific search space. In an example, a UE specific DCI may correspond to an RNTI configured for the wireless device.

**[0065]** A NR system may support a single beam operation and/or a multi-beam operation. In a multi-beam operation, a base station may perform a downlink beam sweeping to provide coverage for common control channels and/or downlink SS blocks, which may comprise at least a PSS, a SSS, and/or PBCH. A wireless device may measure quality of a beam pair link using one or more RSs. One or more SS blocks, or one or more CSI-RS resources, associated with a CSI-RS resource index (CRI), or one or more DM-RSs of PBCH, may be used as RS for measuring quality of a beam pair link. Quality of a beam pair link may be defined as a reference signal received power (RSRP) value, or a reference signal received quality (RSRQ) value, and/or a CSI value measured on RS resources. The base station may indicate whether an RS resource, used for measuring a beam pair link quality, is quasi-co-located (QCLed) with DM-RSs of a control channel. A RS resource and DM-RSs of a control channel may be called QCLed when a channel characteristics from a transmission on an RS to a wireless device, and that from a transmission on a control channel to a wireless device, are similar or same under a configured criterion. In a multi-beam operation, a wireless device may perform an uplink beam sweeping to access a cell.

**[0066]** In an example, a wireless device may be configured to monitor PDCCH on one or more beam pair links simultaneously depending on a capability of a wireless device. This may increase robustness against beam pair link blocking. A base station may transmit one or more messages to configure a wireless device to monitor PDCCH on one or more beam pair links in different PDCCH OFDM symbols. For example, a base station may transmit higher layer signaling (e.g. RRC signaling) or MAC CE comprising parameters related to the Rx beam setting of a wireless device for monitoring PDCCH on one or more beam pair links. A base station may transmit indication of spatial QCL assumption between an DL RS antenna port(s) (for example, cell-specific CSI-RS, or wireless device-specific CSI-RS, or SS block, or PBCH with or without DM-RSs of PBCH), and DL RS antenna port(s) for demodulation of DL control channel. Signaling for beam indication for a PDCCH may be MAC CE signaling, or RRC signaling, or DCI signaling, or specification-transparent and/or implicit method, and combination of these signaling methods.

**[0067]** For reception of unicast DL data channel, a base station may indicate spatial QCL parameters between DL RS

antenna port(s) and DM-RS antenna port(s) of DL data channel. The base station may transmit DCI (e.g. downlink grants) comprising information indicating the RS antenna port(s). The information may indicate RS antenna port(s) which may be QCLed with the DM-RS antenna port(s). Different set of DM-RS antenna port(s) for a DL data channel may be indicated as QCL with different set of the RS antenna port(s).

5 **[0068]** FIG. 9A is an example of beam sweeping in a DL channel. In an RRC\_INACTIVE state or RRC\_IDLE state, a wireless device may assume that SS blocks form an SS burst 940, and an SS burst set 950. The SS burst set 950 may have a given periodicity. For example, in a multi-beam operation, a base station 120 may transmit SS blocks in multiple beams, together forming a SS burst 940. One or more SS blocks may be transmitted on one beam. If multiple SS bursts 940 are transmitted with multiple beams, SS bursts together may form SS burst set 950.

10 **[0069]** A wireless device may further use CSI-RS in the multi-beam operation for estimating a beam quality of a links between a wireless device and a base station. A beam may be associated with a CSI-RS. For example, a wireless device may, based on a RSRP measurement on CSI-RS, report a beam index, as indicated in a CRI for downlink beam selection, and associated with a RSRP value of a beam. A CSI-RS may be transmitted on a CSI-RS resource including at least one of one or more antenna ports, one or more time or frequency radio resources. A CSI-RS resource may be configured in a cell-specific way by common RRC signaling, or in a wireless device-specific way by dedicated RRC signaling, and/or L1/L2 signaling. Multiple wireless devices covered by a cell may measure a cell-specific CSI-RS resource. A dedicated subset of wireless devices covered by a cell may measure a wireless device-specific CSI-RS resource.

15 **[0070]** A CSI-RS resource may be transmitted periodically, or using aperiodic transmission, or using a multi-shot or semi-persistent transmission. For example, in a periodic transmission in FIG. 9A, a base station 120 may transmit configured CSI-RS resources 940 periodically using a configured periodicity in a time domain. In an aperiodic transmission, a configured CSI-RS resource may be transmitted in a dedicated time slot. In a multi-shot or semi-persistent transmission, a configured CSI-RS resource may be transmitted within a configured period. Beams used for CSI-RS transmission may have different beam width than beams used for SS-blocks transmission.

20 **[0071]** FIG. 9B is an example of a beam management procedure in an example new radio network. A base station 120 and/or a wireless device 110 may perform a downlink L1/L2 beam management procedure. One or more of the following downlink L1/L2 beam management procedures may be performed within one or more wireless devices 110 and one or more base stations 120. In an example, a P-1 procedure 910 may be used to enable the wireless device 110 to measure one or more Transmission (Tx) beams associated with the base station 120 to support a selection of a first set of Tx beams associated with the base station 120 and a first set of Rx beam(s) associated with a wireless device 110. For beamforming at a base station 120, a base station 120 may sweep a set of different TX beams. For beamforming at a wireless device 110, a wireless device 110 may sweep a set of different Rx beams. In an example, a P-2 procedure 920 may be used to enable a wireless device 110 to measure one or more Tx beams associated with a base station 120 to possibly change a first set of Tx beams associated with a base station 120. A P-2 procedure 920 may be performed on a possibly smaller set of beams for beam refinement than in the P-1 procedure 910. A P-2 procedure 920 may be a special case of a P-1 procedure 910. In an example, a P-3 procedure 930 may be used to enable a wireless device 110 to measure at least one Tx beam associated with a base station 120 to change a first set of Rx beams associated with a wireless device 110.

25 **[0072]** A wireless device 110 may transmit one or more beam management reports to a base station 120. In one or more beam management reports, a wireless device 110 may indicate some beam pair quality parameters, comprising at least, one or more beam identifications; RSRP; Precoding Matrix Indicator (PMI)/Channel Quality Indicator (CQI)/Rank Indicator (RI) of a subset of configured beams. Based on one or more beam management reports, a base station 120 may transmit to a wireless device 110 a signal indicating that one or more beam pair links are one or more serving beams. A base station 120 may transmit PDCCH and PDSCH for a wireless device 110 using one or more serving beams.

30 **[0073]** In an example embodiment, new radio network may support a Bandwidth Adaptation (BA). In an example, receive and/or transmit bandwidths configured by an UE employing a BA may not be large. For example, a receive and/or transmit bandwidths may not be as large as a bandwidth of a cell. Receive and/or transmit bandwidths may be adjustable. For example, a UE may change receive and/or transmit bandwidths, e.g., to shrink during period of low activity to save power. For example, a UE may change a location of receive and/or transmit bandwidths in a frequency domain, e.g. to increase scheduling flexibility. For example, a UE may change a subcarrier spacing, e.g. to allow different services.

35 **[0074]** In an example embodiment, a subset of a total cell bandwidth of a cell may be referred to as a Bandwidth Part (BWP). A base station may configure a UE with one or more BWPs to achieve a BA. For example, a base station may indicate, to a UE, which of the one or more (configured) BWPs is an active BWP.

40 **[0075]** FIG. 10 is an example diagram of 3 BWPs configured: BWP1 (1010 and 1050) with a width of 40 MHz and subcarrier spacing of 15 kHz; BWP2 (1020 and 1040) with a width of 10 MHz and subcarrier spacing of 15 kHz; BWP3 1030 with a width of 20 MHz and subcarrier spacing of 60 kHz.

45 **[0076]** In an example, a UE, configured for operation in one or more BWPs of a cell, may be configured by one or more higher layers (e.g. RRC layer) for a cell a set of one or more BWPs (e.g., at most four BWPs) for receptions by

the UE (DL BWP set) in a DL bandwidth by at least one parameter DL-BWP and a set of one or more BWPs (e.g., at most four BWPs) for transmissions by a UE (UL BWP set) in an UL bandwidth by at least one parameter UL-BWP for a cell.

**[0077]** To enable BA on the PCell, a base station may configure a UE with one or more UL and DL BWP pairs. To enable BA on SCells (e.g., in case of CA), a base station may configure a UE at least with one or more DL BWPs (e.g., there may be none in an UL).

**[0078]** In an example, an initial active DL BWP may be defined by at least one of a location and number of contiguous PRBs, a subcarrier spacing, or a cyclic prefix, for a control resource set for at least one common search space. For operation on the PCell, one or more higher layer parameters may indicate at least one initial UL BWP for a random access procedure. If a UE is configured with a secondary carrier on a primary cell, the UE may be configured with an initial BWP for random access procedure on a secondary carrier.

**[0079]** In an example, for unpaired spectrum operation, a UE may expect that a center frequency for a DL BWP may be same as a center frequency for a UL BWP.

**[0080]** For example, for a DL BWP or an UL BWP in a set of one or more DL BWPs or one or more UL BWPs, respectively, a base station may semi-statistically configure a UE for a cell with one or more parameters indicating at least one of following: a subcarrier spacing; a cyclic prefix; a number of contiguous PRBs; an index in the set of one or more DL BWPs and/or one or more UL BWPs; a link between a DL BWP and an UL BWP from a set of configured DL BWPs and UL BWPs; a DCI detection to a PDSCH reception timing; a PDSCH reception to a HARQ-ACK transmission timing value; a DCI detection to a PUSCH transmission timing value; an offset of a first PRB of a DL bandwidth or an UL bandwidth, respectively, relative to a first PRB of a bandwidth.

**[0081]** In an example, for a DL BWP in a set of one or more DL BWPs on a PCell, a base station may configure a UE with one or more control resource sets for at least one type of common search space and/or one UE-specific search space. For example, a base station may not configure a UE without a common search space on a PCell, or on a SPCell, in an active DL BWP.

**[0082]** For an UL BWP in a set of one or more UL BWPs, a base station may configure a UE with one or more resource sets for one or more PUCCH transmissions.

**[0083]** In an example, if a DCI comprises a BWP indicator field, a BWP indicator field value may indicate an active DL BWP, from a configured DL BWP set, for one or more DL receptions. If a DCI comprises a BWP indicator field, a BWP indicator field value may indicate an active UL BWP, from a configured UL BWP set, for one or more UL transmissions.

**[0084]** In an example, for a PCell, a base station may semi-statistically configure a UE with a default DL BWP among configured DL BWPs. If a UE is not provided a default DL BWP, a default BWP may be an initial active DL BWP.

**[0085]** In an example, a base station may configure a UE with a timer value for a PCell. For example, a UE may start a timer, referred to as BWP inactivity timer, when a UE detects a DCI indicating an active DL BWP, other than a default DL BWP, for a paired spectrum operation or when a UE detects a DCI indicating an active DL BWP or UL BWP, other than a default DL BWP or UL BWP, for an unpaired spectrum operation. The UE may increment the timer by an interval of a first value (e.g., the first value may be 1 millisecond or 0.5 milliseconds) if the UE does not detect a DCI during the interval for a paired spectrum operation or for an unpaired spectrum operation. In an example, the timer may expire when the timer is equal to the timer value. A UE may switch to the default DL BWP from an active DL BWP when the timer expires.

**[0086]** In an example, a base station may semi-statistically configure a UE with one or more BWPs. A UE may switch an active BWP from a first BWP to a second BWP in response to receiving a DCI indicating the second BWP as an active BWP and/or in response to an expiry of BWP inactivity timer (for example, the second BWP may be a default BWP). For example, FIG. 10 is an example diagram of 3 BWPs configured, BWP1 (1010 and 1050), BWP2 (1020 and 1040), and BWP3 (1030). BWP2 (1020 and 1040) may be a default BWP. BWP1 (1010) may be an initial active BWP. In an example, a UE may switch an active BWP from BWP1 1010 to BWP2 1020 in response to an expiry of BWP inactivity timer. For example, a UE may switch an active BWP from BWP2 1020 to BWP3 1030 in response to receiving a DCI indicating BWP3 1030 as an active BWP. Switching an active BWP from BWP3 1030 to BWP2 1040 and/or from BWP2 1040 to BWP1 1050 may be in response to receiving a DCI indicating an active BWP and/or in response to an expiry of BWP inactivity timer.

**[0087]** In an example, if a UE is configured for a secondary cell with a default DL BWP among configured DL BWPs and a timer value, UE procedures on a secondary cell may be same as on a primary cell using the timer value for the secondary cell and the default DL BWP for the secondary cell.

**[0088]** In an example, if a base station configures a UE with a first active DL BWP and a first active UL BWP on a secondary cell or carrier, a UE may employ an indicated DL BWP and an indicated UL BWP on a secondary cell as a respective first active DL BWP and first active UL BWP on a secondary cell or carrier.

**[0089]** FIG. 11A and FIG. 11B show packet flows employing a multi connectivity (e.g. dual connectivity, multi connectivity, tight interworking, and/or the like). FIG. 11A is an example diagram of a protocol structure of a wireless device 110 (e.g. UE) with CA and/or multi connectivity as per an aspect of an embodiment. FIG. 11B is an example diagram of a protocol structure of multiple base stations with CA and/or multi connectivity as per an aspect of an embodiment.

The multiple base stations may comprise a master node, MN 1130 (e.g. a master node, a master base station, a master gNB, a master eNB, and/or the like) and a secondary node, SN 1150 (e.g. a secondary node, a secondary base station, a secondary gNB, a secondary eNB, and/or the like). A master node 1130 and a secondary node 1150 may co-work to communicate with a wireless device 110.

**[0090]** When multi connectivity is configured for a wireless device 110, the wireless device 110, which may support multiple reception/transmission functions in an RRC connected state, may be configured to utilize radio resources provided by multiple schedulers of a multiple base stations. Multiple base stations may be inter-connected via a non-ideal or ideal backhaul (e.g. Xn interface, X2 interface, and/or the like). A base station involved in multi connectivity for a certain wireless device may perform at least one of two different roles: a base station may either act as a master base station or as a secondary base station. In multi connectivity, a wireless device may be connected to one master base station and one or more secondary base stations. In an example, a master base station (e.g. the MN 1130) may provide a master cell group (MCG) comprising a primary cell and/or one or more secondary cells for a wireless device (e.g. the wireless device 110). A secondary base station (e.g. the SN 1150) may provide a secondary cell group (SCG) comprising a primary secondary cell (SPCell) and/or one or more secondary cells for a wireless device (e.g. the wireless device 110).

**[0091]** In multi connectivity, a radio protocol architecture that a bearer employs may depend on how a bearer is setup. In an example, three different type of bearer setup options may be supported: an MCG bearer, an SCG bearer, and/or a split bearer. A wireless device may receive/transmit packets of an MCG bearer via one or more cells of the MCG, and/or may receive/transmits packets of an SCG bearer via one or more cells of an SCG. Multi-connectivity may also be described as having at least one bearer configured to use radio resources provided by the secondary base station. Multi-connectivity may or may not be configured/implemented in some of the example embodiments.

**[0092]** In an example, a wireless device (e.g. Wireless Device 110) may transmit and/or receive: packets of an MCG bearer via an SDAP layer (e.g. SDAP 1110), a PDCP layer (e.g. NR PDCP 1111), an RLC layer (e.g. MN RLC 1114), and a MAC layer (e.g. MN MAC 1118); packets of a split bearer via an SDAP layer (e.g. SDAP 1110), a PDCP layer (e.g. NR PDCP 1112), one of a master or secondary RLC layer (e.g. MN RLC 1115, SN RLC 1116), and one of a master or secondary MAC layer (e.g. MN MAC 1118, SN MAC 1119); and/or packets of an SCG bearer via an SDAP layer (e.g. SDAP 1110), a PDCP layer (e.g. NR PDCP 1113), an RLC layer (e.g. SN RLC 1117), and a MAC layer (e.g. MN MAC 1119).

**[0093]** In an example, a master base station (e.g. MN 1130) and/or a secondary base station (e.g. SN 1150) may transmit/receive: packets of an MCG bearer via a master or secondary node SDAP layer (e.g. SDAP 1120, SDAP 1140), a master or secondary node PDCP layer (e.g. NR PDCP 1121, NR PDCP 1142), a master node RLC layer (e.g. MN RLC 1124, MN RLC 1125), and a master node MAC layer (e.g. MN MAC 1128); packets of an SCG bearer via a master or secondary node SDAP layer (e.g. SDAP 1120, SDAP 1140), a master or secondary node PDCP layer (e.g. NR PDCP 1122, NR PDCP 1143), a secondary node RLC layer (e.g. SN RLC 1146, SN RLC 1147), and a secondary node MAC layer (e.g. SN MAC 1148); packets of a split bearer via a master or secondary node SDAP layer (e.g. SDAP 1120, SDAP 1140), a master or secondary node PDCP layer (e.g. NR PDCP 1123, NR PDCP 1141), a master or secondary node RLC layer (e.g. MN RLC 1126, SN RLC 1144, SN RLC 1145, MN RLC 1127), and a master or secondary node MAC layer (e.g. MN MAC 1128, SN MAC 1148).

**[0094]** In multi connectivity, a wireless device may configure multiple MAC entities: one MAC entity (e.g. MN MAC 1118) for a master base station, and other MAC entities (e.g. SN MAC 1119) for a secondary base station. In multi-connectivity, a configured set of serving cells for a wireless device may comprise two subsets: an MCG comprising serving cells of a master base station, and SCGs comprising serving cells of a secondary base station. For an SCG, one or more of following configurations may be applied: at least one cell of an SCG has a configured UL CC and at least one cell of a SCG, named as primary secondary cell (SPCell, PCell of SCG, or sometimes called PCell), is configured with PUCCH resources; when an SCG is configured, there may be at least one SCG bearer or one Split bearer; upon detection of a physical layer problem or a random access problem on a SPCell, or a number of NR RLC retransmissions has been reached associated with the SCG, or upon detection of an access problem on a SPCell during a SCG addition or a SCG change: an RRC connection re-establishment procedure may not be triggered, UL transmissions towards cells of an SCG may be stopped, a master base station may be informed by a wireless device of a SCG failure type, for split bearer, a DL data transfer over a master base station may be maintained; an NR RLC acknowledged mode (AM) bearer may be configured for a split bearer; PCell and/or SPCell may not be de-activated; SPCell may be changed with a SCG change procedure (e.g. with security key change and a RACH procedure); and/or a bearer type change between a split bearer and a SCG bearer or simultaneous configuration of a SCG and a split bearer may or may not supported.

**[0095]** With respect to interaction between a master base station and a secondary base stations for multi-connectivity, one or more of the following may be applied: a master base station and/or a secondary base station may maintain Radio Resource Management (RRM) measurement configurations of a wireless device; a master base station may (e.g. based on received measurement reports, traffic conditions, and/or bearer types) may decide to request a secondary base station to provide additional resources (e.g. serving cells) for a wireless device; upon receiving a request from a master base station, a secondary base station may create/modify a container that may result in configuration of additional

5 serving cells for a wireless device (or decide that the secondary base station has no resource available to do so); for a UE capability coordination, a master base station may provide (a part of) an AS configuration and UE capabilities to a secondary base station; a master base station and a secondary base station may exchange information about a UE configuration by employing of RRC containers (inter-node messages) carried via Xn messages; a secondary base station may initiate a reconfiguration of the secondary base station existing serving cells (e.g. PUCCH towards the secondary base station); a secondary base station may decide which cell is a SPCell within a SCG; a master base station may or may not change content of RRC configurations provided by a secondary base station; in case of a SCG addition and/or a SCG SCell addition, a master base station may provide recent (or the latest) measurement results for SCG cell(s); a master base station and secondary base stations may receive information of SFN and/or subframe offset of each other from OAM and/or via an Xn interface, (e.g. for a purpose of DRX alignment and/or identification of a measurement gap). In an example, when adding a new SCG SCell, dedicated RRC signaling may be used for sending required system information of a cell as for CA, except for a SFN acquired from a MIB of a SPCell of a SCG.

10 **[0096]** FIG. 12 is an example diagram of a random access procedure. One or more events may trigger a random access procedure. For example, one or more events may be at least one of following: initial access from RRC\_IDLE, RRC connection re-establishment procedure, handover, DL or UL data arrival during RRC\_CONNECTED when UL synchronization status is non-synchronized, transition from RRC\_Inactive, and/or request for other system information. For example, a PDCCH order, a MAC entity, and/or a beam failure indication may initiate a random access procedure.

15 **[0097]** In an example embodiment, a random access procedure may be at least one of a contention based random access procedure and a contention free random access procedure. For example, a contention based random access procedure may comprise, one or more Msg 1 1220 transmissions, one or more Msg2 1230 transmissions, one or more Msg3 1240 transmissions, and contention resolution 1250. For example, a contention free random access procedure may comprise one or more Msg 1 1220 transmissions and one or more Msg2 1230 transmissions.

20 **[0098]** In an example, a base station may transmit (e.g., unicast, multicast, or broadcast), to a UE, a RACH configuration 1210 via one or more beams. The RACH configuration 1210 may comprise one or more parameters indicating at least one of following: available set of PRACH resources for a transmission of a random access preamble, initial preamble power (e.g., random access preamble initial received target power), an RSRP threshold for a selection of a SS block and corresponding PRACH resource, a power-ramping factor (e.g., random access preamble power ramping step), random access preamble index, a maximum number of preamble transmission, preamble group A and group B, a threshold (e.g., message size) to determine the groups of random access preambles, a set of one or more random access preambles for system information request and corresponding PRACH resource(s), if any, a set of one or more random access preambles for beam failure recovery request and corresponding PRACH resource(s), if any, a time window to monitor RA response(s), a time window to monitor response(s) on beam failure recovery request, and/or a contention resolution timer.

25 **[0099]** In an example, the Msg1 1220 may be one or more transmissions of a random access preamble. For a contention based random access procedure, a UE may select a SS block with a RSRP above the RSRP threshold. If random access preambles group B exists, a UE may select one or more random access preambles from a group A or a group B depending on a potential Msg3 1240 size. If a random access preambles group B does not exist, a UE may select the one or more random access preambles from a group A. A UE may select a random access preamble index randomly (e.g. with equal probability or a normal distribution) from one or more random access preambles associated with a selected group. If a base station semi-statistically configures a UE with an association between random access preambles and SS blocks, the UE may select a random access preamble index randomly with equal probability from one or more random access preambles associated with a selected SS block and a selected group.

30 **[0100]** For example, a UE may initiate a contention free random access procedure based on a beam failure indication from a lower layer. For example, a base station may semi-statistically configure a UE with one or more contention free PRACH resources for beam failure recovery request associated with at least one of SS blocks and/or CSI-RSs. If at least one of SS blocks with a RSRP above a first RSRP threshold amongst associated SS blocks or at least one of CSI-RSs with a RSRP above a second RSRP threshold amongst associated CSI-RSs is available, a UE may select a random access preamble index corresponding to a selected SS block or CSI-RS from a set of one or more random access preambles for beam failure recovery request.

35 **[0101]** For example, a UE may receive, from a base station, a random access preamble index via PDCCH or RRC for a contention free random access procedure. If a base station does not configure a UE with at least one contention free PRACH resource associated with SS blocks or CSI-RS, the UE may select a random access preamble index. If a base station configures a UE with one or more contention free PRACH resources associated with SS blocks and at least one SS block with a RSRP above a first RSRP threshold amongst associated SS blocks is available, the UE may select the at least one SS block and select a random access preamble corresponding to the at least one SS block. If a base station configures a UE with one or more contention free PRACH resources associated with CSI-RSs and at least one CSI-RS with a RSRP above a second RSRP threshold amongst the associated CSI-RSs is available, the UE may select the at least one CSI-RS and select a random access preamble corresponding to the at least one CSI-RS.

**[0102]** A UE may perform one or more Msg1 1220 transmissions by transmitting the selected random access preamble. For example, if a UE selects an SS block and is configured with an association between one or more PRACH occasions and one or more SS blocks, the UE may determine an PRACH occasion from one or more PRACH occasions corresponding to a selected SS block. For example, if a UE selects a CSI-RS and is configured with an association between one or more PRACH occasions and one or more CSI-RSs, the UE may determine a PRACH occasion from one or more PRACH occasions corresponding to a selected CSI-RS. A UE may transmit, to a base station, a selected random access preamble via a selected PRACH occasions. A UE may determine a transmit power for a transmission of a selected random access preamble at least based on an initial preamble power and a power-ramping factor. A UE may determine a RA-RNTI associated with a selected PRACH occasions in which a selected random access preamble is transmitted. For example, a UE may not determine a RA-RNTI for a beam failure recovery request. A UE may determine an RA-RNTI at least based on an index of a first OFDM symbol and an index of a first slot of a selected PRACH occasions, and/or an uplink carrier index for a transmission of Msg1 1220.

**[0103]** In an example, a UE may receive, from a base station, a random access response, Msg 2 1230. A UE may start a time window (e.g., *ra-ResponseWindow*) to monitor a random access response. For beam failure recovery request, a base station may configure a UE with a different time window (e.g., *bfr-Response Window*) to monitor response on beam failure recovery request. For example, a UE may start a time window (e.g., *ra-ResponseWindow* or *bfr-ResponseWindow*) at a start of a first PDCCH occasion after a fixed duration of one or more symbols from an end of a preamble transmission. If a UE transmits multiple preambles, the UE may start a time window at a start of a first PDCCH occasion after a fixed duration of one or more symbols from an end of a first preamble transmission. A UE may monitor a PDCCH of a cell for at least one random access response identified by a RA-RNTI or for at least one response to beam failure recovery request identified by a C-RNTI while a timer for a time window is running.

**[0104]** In an example, a UE may consider a reception of random access response successful if at least one random access response comprises a random access preamble identifier corresponding to a random access preamble transmitted by the UE. A UE may consider the contention free random access procedure successfully completed if a reception of random access response is successful. If a contention free random access procedure is triggered for a beam failure recovery request, a UE may consider a contention free random access procedure successfully complete if a PDCCH transmission is addressed to a C-RNTI. In an example, if at least one random access response comprises a random access preamble identifier, a UE may consider the random access procedure successfully completed and may indicate a reception of an acknowledgement for a system information request to upper layers. If a UE has signaled multiple preamble transmissions, the UE may stop transmitting remaining preambles (if any) in response to a successful reception of a corresponding random access response.

**[0105]** In an example, a UE may perform one or more Msg 3 1240 transmissions in response to a successful reception of random access response (e.g., for a contention based random access procedure). A UE may adjust an uplink transmission timing based on a timing advanced command indicated by a random access response and may transmit one or more transport blocks based on an uplink grant indicated by a random access response. Subcarrier spacing for PUSCH transmission for Msg3 1240 may be provided by at least one higher layer (e.g. RRC) parameter. A UE may transmit a random access preamble via PRACH and Msg3 1240 via PUSCH on a same cell. A base station may indicate an UL BWP for a PUSCH transmission of Msg3 1240 via system information block. A UE may employ HARQ for a retransmission of Msg 3 1240.

**[0106]** In an example, multiple UEs may perform Msg 1 1220 by transmitting a same preamble to a base station and receive, from the base station, a same random access response comprising an identity (e.g., TC-RNTI). Contention resolution 1250 may ensure that a UE does not incorrectly use an identity of another UE. For example, contention resolution 1250 may be based on C-RNTI on PDCCH or a UE contention resolution identity on DL-SCH. For example, if a base station assigns a C-RNTI to a UE, the UE may perform contention resolution 1250 based on a reception of a PDCCH transmission that is addressed to the C-RNTI. In response to detection of a C-RNTI on a PDCCH, a UE may consider contention resolution 1250 successful and may consider a random access procedure successfully completed. If a UE has no valid C-RNTI, a contention resolution may be addressed by employing a TC-RNTI. For example, if a MAC PDU is successfully decoded and a MAC PDU comprises a UE contention resolution identity MAC CE that matches the CCCH SDU transmitted in Msg3 1250, a UE may consider the contention resolution 1250 successful and may consider the random access procedure successfully completed.

**[0107]** FIG. 13 is an example structure for MAC entities as per an aspect of an embodiment. In an example, a wireless device may be configured to operate in a multi-connectivity mode. A wireless device in RRC\_CONNECTED with multiple RX/TX may be configured to utilize radio resources provided by multiple schedulers located in a plurality of base stations. The plurality of base stations may be connected via a non-ideal or ideal backhaul over the Xn interface. In an example, a base station in a plurality of base stations may act as a master base station or as a secondary base station. A wireless device may be connected to one master base station and one or more secondary base stations. A wireless device may be configured with multiple MAC entities, e.g. one MAC entity for master base station, and one or more other MAC entities for secondary base station(s). In an example, a configured set of serving cells for a wireless device may comprise

two subsets: an MCG comprising serving cells of a master base station, and one or more SCGs comprising serving cells of a secondary base station(s). Figure 13 illustrates an example structure for MAC entities when MCG and SCG are configured for a wireless device.

**[0108]** In an example, at least one cell in a SCG may have a configured UL CC, wherein a cell of at least one cell may be called SPCell or PCell of SCG, or sometimes may be simply called PCell. A SPCell may be configured with PUCCH resources. In an example, when a SCG is configured, there may be at least one SCG bearer or one split bearer. In an example, upon detection of a physical layer problem or a random access problem on a SPCell, or upon reaching a number of RLC retransmissions associated with the SCG, or upon detection of an access problem on a SPCell during a SCG addition or a SCG change: an RRC connection re-establishment procedure may not be triggered, UL transmissions towards cells of an SCG may be stopped, a master base station may be informed by a UE of a SCG failure type and DL data transfer over a master base station may be maintained.

**[0109]** In an example, a MAC sublayer may provide services such as data transfer and radio resource allocation to upper layers (e.g. 1310 or 1320). A MAC sublayer may comprise a plurality of MAC entities (e.g. 1350 and 1360). A MAC sublayer may provide data transfer services on logical channels. To accommodate different kinds of data transfer services, multiple types of logical channels may be defined. A logical channel may support transfer of a particular type of information. A logical channel type may be defined by what type of information (e.g., control or data) is transferred. For example, BCCH, PCCH, CCCH and DCCH may be control channels and DTCH may be a traffic channel. In an example, a first MAC entity (e.g. 1310) may provide services on PCCH, BCCH, CCCH, DCCH, DTCH and MAC control elements. In an example, a second MAC entity (e.g. 1320) may provide services on BCCH, DCCH, DTCH and MAC control elements.

**[0110]** A MAC sublayer may expect from a physical layer (e.g. 1330 or 1340) services such as data transfer services, signaling of HARQ feedback, signaling of scheduling request or measurements (e.g. CQI). In an example, in dual connectivity, two MAC entities may be configured for a wireless device: one for MCG and one for SCG. A MAC entity of wireless device may handle a plurality of transport channels. In an example, a first MAC entity may handle first transport channels comprising a PCCH of MCG, a first BCH of MCG, one or more first DL-SCHs of MCG, one or more first UL-SCHs of MCG and one or more first RACHs of MCG. In an example, a second MAC entity may handle second transport channels comprising a second BCH of SCG, one or more second DL-SCHs of SCG, one or more second UL-SCHs of SCG and one or more second RACHs of SCG.

**[0111]** In an example, if a MAC entity is configured with one or more SCells, there may be multiple DL-SCHs and there may be multiple UL-SCHs as well as multiple RACHs per MAC entity. In an example, there may be one DL-SCH and UL-SCH on a SpCell. In an example, there may be one DL-SCH, zero or one UL-SCH and zero or one RACH for an SCell. A DL-SCH may support receptions using different numerologies and/or TTI duration within a MAC entity. A UL-SCH may also support transmissions using different numerologies and/or TTI duration within the MAC entity.

**[0112]** In an example, a MAC sublayer may support different functions and may control these functions with a control (e.g. 1355 or 1365) element. Functions performed by a MAC entity may comprise mapping between logical channels and transport channels (e.g., in uplink or downlink), multiplexing (e.g. 1352 or 1362) of MAC SDUs from one or different logical channels onto transport blocks (TB) to be delivered to the physical layer on transport channels (e.g., in uplink), demultiplexing (e.g. 1352 or 1362) of MAC SDUs to one or different logical channels from transport blocks (TB) delivered from the physical layer on transport channels (e.g., in downlink), scheduling information reporting (e.g., in uplink), error correction through HARQ in uplink or downlink (e.g. 1363), and logical channel prioritization in uplink (e.g. 1351 or 1361). A MAC entity may handle a random access process (e.g. 1354 or 1364).

**[0113]** FIG. 14 is an example diagram of a RAN architecture comprising one or more base stations. In an example, a protocol stack (e.g. RRC, SDAP, PDCP, RLC, MAC, and PHY) may be supported at a node. A base station (e.g. gNB 120A or 120B) may comprise a base station central unit (CU) (e.g. gNB-CU 1420A or 1420B) and at least one base station distributed unit (DU) (e.g. gNB-DU 1430A, 1430B, 1430C, or 1430D) if a functional split is configured. Upper protocol layers of a base station may be located in a base station CU, and lower layers of the base station may be located in the base station DUs. An F1 interface (e.g. CU-DU interface) connecting a base station CU and base station DUs may be an ideal or non-ideal backhaul. F1-C may provide a control plane connection over an F1 interface, and F1-U may provide a user plane connection over the F1 interface. In an example, an Xn interface may be configured between base station CUs.

**[0114]** In an example, a base station CU may comprise an RRC function, an SDAP layer, and a PDCP layer, and base station DUs may comprise an RLC layer, a MAC layer, and a PHY layer. In an example, various functional split options between a base station CU and base station DUs may be possible by locating different combinations of upper protocol layers (RAN functions) in a base station CU and different combinations of lower protocol layers (RAN functions) in base station DUs. A functional split may support flexibility to move protocol layers between a base station CU and base station DUs depending on service requirements and/or network environments.

**[0115]** In an example, functional split options may be configured per base station, per base station CU, per base station DU, per UE, per bearer, per slice, or with other granularities. In per base station CU split, a base station CU may have

a fixed split option, and base station DUs may be configured to match a split option of a base station CU. In per base station DU split, a base station DU may be configured with a different split option, and a base station CU may provide different split options for different base station DUs. In per UE split, a base station (base station CU and at least one base station DUs) may provide different split options for different wireless devices. In per bearer split, different split options may be utilized for different bearers. In per slice splice, different split options may be applied for different slices.

5 **[0116]** FIG. 15 is an example diagram showing RRC state transitions of a wireless device. In an example, a wireless device may be in at least one RRC state among an RRC connected state (e.g. RRC Connected 1530, RRC\_Connected), an RRC idle state (e.g. RRC Idle 1510, RRC\_Idle), and/or an RRC inactive state (e.g. RRC Inactive 1520, RRC\_Inactive). In an example, in an RRC connected state, a wireless device may have at least one RRC connection with at least one base station (e.g. gNB and/or eNB), which may have a UE context of the wireless device. A UE context (e.g. a wireless device context) may comprise at least one of an access stratum context, one or more radio link configuration parameters, bearer (e.g. data radio bearer (DRB), signaling radio bearer (SRB), logical channel, QoS flow, PDU session, and/or the like) configuration information, security information, PHY/MAC/RLC/PDCP/SDAP layer configuration information, and/or the like configuration information for a wireless device. In an example, in an RRC idle state, a wireless device may not have an RRC connection with a base station, and a UE context of a wireless device may not be stored in a base station. In an example, in an RRC inactive state, a wireless device may not have an RRC connection with a base station. A UE context of a wireless device may be stored in a base station, which may be called as an anchor base station (e.g. last serving base station).

10 **[0117]** In an example, a wireless device may transition a UE RRC state between an RRC idle state and an RRC connected state in both ways (e.g. connection release 1540 or connection establishment 1550; or connection reestablishment) and/or between an RRC inactive state and an RRC connected state in both ways (e.g. connection inactivation 1570 or connection resume 1580). In an example, a wireless device may transition its RRC state from an RRC inactive state to an RRC idle state (e.g. connection release 1560).

15 **[0118]** In an example, an anchor base station may be a base station that may keep a UE context (a wireless device context) of a wireless device at least during a time period that a wireless device stays in a RAN notification area (RNA) of an anchor base station, and/or that a wireless device stays in an RRC inactive state. In an example, an anchor base station may be a base station that a wireless device in an RRC inactive state was lastly connected to in a latest RRC connected state or that a wireless device lastly performed an RNA update procedure in. In an example, an RNA may comprise one or more cells operated by one or more base stations. In an example, a base station may belong to one or more RNAs. In an example, a cell may belong to one or more RNAs.

20 **[0119]** In an example, a wireless device may transition a UE RRC state from an RRC connected state to an RRC inactive state in a base station. A wireless device may receive RNA information from the base station. RNA information may comprise at least one of an RNA identifier, one or more cell identifiers of one or more cells of an RNA, a base station identifier, an IP address of the base station, an AS context identifier of the wireless device, a resume identifier, and/or the like.

25 **[0120]** In an example, an anchor base station may broadcast a message (e.g. RAN paging message) to base stations of an RNA to reach to a wireless device in an RRC inactive state, and/or the base stations receiving the message from the anchor base station may broadcast and/or multicast another message (e.g. paging message) to wireless devices in their coverage area, cell coverage area, and/or beam coverage area associated with the RNA through an air interface.

30 **[0121]** In an example, when a wireless device in an RRC inactive state moves into a new RNA, the wireless device may perform an RNA update (RNAU) procedure, which may comprise a random access procedure by the wireless device and/or a UE context retrieve procedure. A UE context retrieve may comprise: receiving, by a base station from a wireless device, a random access preamble; and fetching, by a base station, a UE context of the wireless device from an old anchor base station. Fetching may comprise: sending a retrieve UE context request message comprising a resume identifier to the old anchor base station and receiving a retrieve UE context response message comprising the UE context of the wireless device from the old anchor base station.

35 **[0122]** In an example embodiment, a wireless device in an RRC inactive state may select a cell to camp on based on at least a on measurement results for one or more cells, a cell where a wireless device may monitor an RNA paging message and/or a core network paging message from a base station. In an example, a wireless device in an RRC inactive state may select a cell to perform a random access procedure to resume an RRC connection and/or to transmit one or more packets to a base station (e.g. to a network). In an example, if a cell selected belongs to a different RNA from an RNA for a wireless device in an RRC inactive state, the wireless device may initiate a random access procedure to perform an RNA update procedure. In an example, if a wireless device in an RRC inactive state has one or more packets, in a buffer, to transmit to a network, the wireless device may initiate a random access procedure to transmit one or more packets to a base station of a cell that the wireless device selects. A random access procedure may be performed with two messages (e.g. 2 stage random access) and/or four messages (e.g. 4 stage random access) between the wireless device and the base station.

40 **[0123]** In an example embodiment, a base station receiving one or more uplink packets from a wireless device in an

RRC inactive state may fetch a UE context of a wireless device by transmitting a retrieve UE context request message for the wireless device to an anchor base station of the wireless device based on at least one of an AS context identifier, an RNA identifier, a base station identifier, a resume identifier, and/or a cell identifier received from the wireless device. In response to fetching a UE context, a base station may transmit a path switch request for a wireless device to a core network entity (e.g. AMF, MME, and/or the like). A core network entity may update a downlink tunnel endpoint identifier for one or more bearers established for the wireless device between a user plane core network entity (e.g. UPF, S-GW, and/or the like) and a RAN node (e.g. the base station), e.g. changing a downlink tunnel endpoint identifier from an address of the anchor base station to an address of the base station.

**[0124]** A gNB may communicate with a wireless device via a wireless network employing one or more new radio technologies. The one or more radio technologies may comprise at least one of: multiple technologies related to physical layer; multiple technologies related to medium access control layer; and/or multiple technologies related to radio resource control layer. Example embodiments of enhancing the one or more radio technologies may improve performance of a wireless network. Example embodiments may increase the system throughput, or data rate of transmission. Example embodiments may reduce battery consumption of a wireless device. Example embodiments may improve latency of data transmission between a gNB and a wireless device. Example embodiments may improve network coverage of a wireless network. Example embodiments may improve transmission efficiency of a wireless network.

**[0125]** A gNB may transmit one or more MAC PDUs to a wireless device. In an example, a MAC PDU may be a bit string that is byte aligned (e.g., a multiple of eight bits) in length. In an example, bit strings may be represented by tables in which the most significant bit is the leftmost bit of the first line of the table, and the least significant bit is the rightmost bit on the last line of the table. More generally, the bit string may be read from left to right and then in the reading order of the lines. In an example, the bit order of a parameter field within a MAC PDU is represented with the first and most significant bit in the leftmost bit and the last and least significant bit in the rightmost bit.

**[0126]** In an example, a MAC SDU may be a bit string that is byte aligned (e.g., a multiple of eight bits) in length. In an example, a MAC SDU may be included in a MAC PDU from the first bit onward.

**[0127]** In an example, a MAC CE may be a bit string that is byte aligned (e.g., a multiple of eight bits) in length.

**[0128]** In an example, a MAC subheader may be a bit string that is byte aligned (e.g., a multiple of eight bits) in length. In an example, a MAC subheader may be placed immediately in front of a corresponding MAC SDU, MAC CE, or padding.

**[0129]** In an example, a MAC entity may ignore a value of reserved bits in a DL MAC PDU.

**[0130]** In an example, a MAC PDU may comprise one or more MAC subPDUs. A MAC subPDU of the one or more MAC subPDUs may comprise: a MAC subheader only (including padding); a MAC subheader and a MAC SDU; a MAC subheader and a MAC CE; and/or a MAC subheader and padding. In an example, the MAC SDU may be of variable size. In an example, a MAC subheader may correspond to a MAC SDU, a MAC CE, or padding.

**[0131]** In an example, when a MAC subheader corresponds to a MAC SDU, a variable-sized MAC CE, or padding, the MAC subheader may comprise: an R field with a one bit length; an F field with a one bit length; an LCID field with a multi-bit length; and/or an L field with a multi-bit length.

**[0132]** FIG. 16A shows an example of a MAC subheader with an R field, an F field, an LCID field, and an L field. In the example MAC subheader of FIG. 16A, the LCID field may be six bits in length, and the L field may be eight bits in length. FIG. 16B shows example of a MAC subheader with an R field, an F field, an LCID field, and an L field. In the example MAC subheader of FIG. 16B, the LCID field may be six bits in length, and the L field may be sixteen bits in length.

**[0133]** In an example, when a MAC subheader corresponds to a fixed sized MAC CE or padding, the MAC subheader may comprise: an R field with a two bit length and an LCID field with a multi-bit length. FIG. 16C shows an example of a MAC subheader with an R field and an LCID field. In the example MAC subheader of FIG. 16C, the LCID field may be six bits in length, and the R field may be two bits in length.

**[0134]** FIG. 17A shows an example of a DL MAC PDU. In the example of FIG. 17A, multiple MAC CEs, such as MAC CE 1 and 2, may be placed together. A MAC subPDU comprising a MAC CE may be placed before any MAC subPDU comprising a MAC SDU or a MAC subPDU comprising padding.

**[0135]** FIG. 17B shows an example of a UL MAC PDU. In the example of FIG. 17B, multiple MAC CEs, such as MAC CE 1 and 2, may be placed together. A MAC subPDU comprising a MAC CE may be placed after all MAC subPDUs comprising a MAC SDU. In addition, the MAC subPDU may be placed before a MAC subPDU comprising padding.

**[0136]** In an example, a MAC entity of a gNB may transmit one or more MAC CEs to a MAC entity of a wireless device. FIG. 18 shows an example of multiple LCIDs that may be associated with the one or more MAC CEs. In the example of FIG. 18, the one or more MAC CEs comprise at least one of: a SP ZP CSI-RS Resource Set Activation/Deactivation MAC CE; a PUCCH spatial relation Activation/Deactivation MAC CE; a SP SRS Activation/Deactivation MAC CE; a SP CSI reporting on PUCCH Activation/Deactivation MAC CE; a TCI State Indication for UE-specific PDCCH MAC CE; a TCI State Indication for UE-specific PDSCH MAC CE; an Aperiodic CSI Trigger State Subselection MAC CE; a SP CSI-RS/CSI-IM Resource Set Activation/Deactivation MAC CE; a UE contention resolution identity MAC CE; a timing advance command MAC CE; a DRX command MAC CE; a Long DRX command MAC CE; an SCell activation/deactivation MAC CE (1 Octet); an SCell activation/deactivation MAC CE (4 Octet); and/or a duplication activation/deactivation MAC CE.

In an example, a MAC CE, such as a MAC CE transmitted by a MAC entity of a gNB to a MAC entity of a wireless device, may have an LCID in the MAC subheader corresponding to the MAC CE. Different MAC CE may have different LCID in the MAC subheader corresponding to the MAC CE. For example, an LCID given by 111011 in a MAC subheader may indicate that a MAC CE associated with the MAC subheader is a long DRX command MAC CE.

**[0137]** In an example, the MAC entity of the wireless device may transmit to the MAC entity of the gNB one or more MAC CEs. FIG. 19 shows an example of the one or more MAC CEs. The one or more MAC CEs may comprise at least one of: a short buffer status report (BSR) MAC CE; a long BSR MAC CE; a C-RNTI MAC CE; a configured grant confirmation MAC CE; a single entry PHR MAC CE; a multiple entry PHR MAC CE; a short truncated BSR; and/or a long truncated BSR. In an example, a MAC CE may have an LCID in the MAC subheader corresponding to the MAC CE. Different MAC CE may have different LCID in the MAC subheader corresponding to the MAC CE. For example, an LCID given by 111011 in a MAC subheader may indicate that a MAC CE associated with the MAC subheader is a short-truncated command MAC CE.

**[0138]** In carrier aggregation (CA), two or more component carriers (CCs) may be aggregated. A wireless device may simultaneously receive or transmit on one or more CCs, depending on capabilities of the wireless device, using the technique of CA. In an example, a wireless device may support CA for contiguous CCs and/or for non-contiguous CCs. CCs may be organized into cells. For example, CCs may be organized into one primary cell (PCell) and one or more secondary cells (SCells).

**[0139]** When configured with CA, a wireless device may have one RRC connection with a network. During an RRC connection establishment/re-establishment/handover, a cell providing NAS mobility information may be a serving cell. During an RRC connection re-establishment/handover procedure, a cell providing a security input may be a serving cell. In an example, the serving cell may denote a PCell. In an example, a gNB may transmit, to a wireless device, one or more messages comprising configuration parameters of a plurality of one or more SCells, depending on capabilities of the wireless device.

**[0140]** When configured with CA, a base station and/or a wireless device may employ an activation/deactivation mechanism of an SCell to improve battery or power consumption of the wireless device. When a wireless device is configured with one or more SCells, a gNB may activate or deactivate at least one of the one or more SCells. Upon configuration of an SCell, the SCell may be deactivated unless an SCell state associated with the SCell is set to "activated" or "dormant".

**[0141]** In an example, a wireless device may activate/deactivate an SCell in response to receiving an SCell Activation/Deactivation MAC CE.

**[0142]** In an example, a gNB may transmit, to a wireless device, one or more messages comprising an SCell timer (e.g., *sCellDeactivationTimer*). In an example, a wireless device may deactivate an SCell in response to an expiry of the SCell timer.

**[0143]** When a wireless device receives an SCell Activation/Deactivation MAC CE activating an SCell, the wireless device may activate the SCell. In response to the activating the SCell, the wireless device may perform operations comprising: SRS transmissions on the SCell; CQI/PMI/RI/CRI reporting for the SCell; PDCCH monitoring on the SCell; PDCCH monitoring for the SCell; and/or PUCCH transmissions on the SCell.

**[0144]** In an example, in response to the activating the SCell, the wireless device may start or restart a first SCell timer (e.g., *sCellDeactivationTimer*) associated with the SCell. The wireless device may start or restart the first SCell timer in the slot when the SCell Activation/Deactivation MAC CE activating the SCell has been received. In an example, in response to the activating the SCell, the wireless device may (re-)initialize one or more suspended configured uplink grants of a configured grant Type 1 associated with the SCell according to a stored configuration. In an example, in response to the activating the SCell, the wireless device may trigger PHR.

**[0145]** When a wireless device receives an SCell Activation/Deactivation MAC CE deactivating an activated SCell, the wireless device may deactivate the activated SCell. In an example, when a first SCell timer (e.g., *sCellDeactivationTimer*) associated with an activated SCell expires, the wireless device may deactivate the activated SCell. In response to the deactivating the activated SCell, the wireless device may stop the first SCell timer associated with the activated SCell. In an example, in response to the deactivating the activated SCell, the wireless device may clear one or more configured downlink assignments and/or one or more configured uplink grants of a configured uplink grant Type 2 associated with the activated SCell. In an example, in response to the deactivating the activated SCell, the wireless device may: suspend one or more configured uplink grants of a configured uplink grant Type 1 associated with the activated SCell; and/or flush HARQ buffers associated with the activated SCell.

**[0146]** In an example, when an SCell is deactivated, a wireless device may not perform operations comprising: transmitting SRS on the SCell; reporting CQI/PMI/RI/CRI for the SCell; transmitting on UL-SCH on the SCell; transmitting on RACH on the SCell; monitoring at least one first PDCCH on the SCell; monitoring at least one second PDCCH for the SCell; and/or transmitting a PUCCH on the SCell.

**[0147]** In an example, when at least one first PDCCH on an activated SCell indicates an uplink grant or a downlink assignment, a wireless device may restart a first SCell timer (e.g., *sCellDeactivationTimer*) associated with the activated

SCell. In an example, when at least one second PDCCH on a serving cell (e.g. a PCell or an SCell configured with PUCCH, e.g. PUCCH SCell) scheduling the activated SCell indicates an uplink grant or a downlink assignment for the activated SCell, a wireless device may restart the first SCell timer (e.g., *sCellDeactivationTimer*) associated with the activated SCell.

**[0148]** In an example, when an SCell is deactivated, if there is an ongoing random access procedure on the SCell, a wireless device may abort the ongoing random access procedure on the SCell.

**[0149]** FIG. 20A shows an example of an SCell Activation/Deactivation MAC CE of one octet. A first MAC PDU subheader with a first LCID (e.g., '111010' as shown in FIG. 18) may identify the SCell Activation/Deactivation MAC CE of one octet. The SCell Activation/Deactivation MAC CE of one octet may have a fixed size. The SCell Activation/Deactivation MAC CE of one octet may comprise a single octet. The single octet may comprise a first number of C-fields (e.g. seven) and a second number of R-fields (e.g., one).

**[0150]** FIG. 20B shows an example of an SCell Activation/Deactivation MAC CE of four octets. A second MAC PDU subheader with a second LCID (e.g., '111001' as shown in FIG. 18) may identify the SCell Activation/Deactivation MAC CE of four octets. The SCell Activation/Deactivation MAC CE of four octets may have a fixed size. The SCell Activation/Deactivation MAC CE of four octets may comprise four octets. The four octets may comprise a third number of C-fields (e.g., 31) and a fourth number of R-fields (e.g., 1).

**[0151]** In FIG. 20A and/or FIG. 20B, a  $C_i$  field may indicate an activation/deactivation status of an SCell with an SCell index  $i$  if an SCell with SCell index  $i$  is configured. In an example, when the  $C_i$  field is set to one, an SCell with an SCell index  $i$  may be activated. In an example, when the  $C_i$  field is set to zero, an SCell with an SCell index  $i$  may be deactivated. In an example, if there is no SCell configured with SCell index  $i$ , the wireless device may ignore the  $C_i$  field. In FIG. 20A and FIG. 20B, an R field may indicate a reserved bit. The R field may be set to zero.

**[0152]** When configured with CA, a base station and/or a wireless device may employ a hibernation mechanism for an SCell to improve battery or power consumption of the wireless device and/or to improve latency of SCell activation/addition. When the wireless device hibernates the SCell, the SCell may be transitioned into a dormant state. In response to the SCell being transitioned into a dormant state, the wireless device may: stop transmitting SRS on the SCell; report CQI/PMI/RI/PTI/CRI for the SCell according to a periodicity configured for the SCell in a dormant state; not transmit on UL-SCH on the SCell; not transmit on RACH on the SCell; not monitor the PDCCH on the SCell; not monitor the PDCCH for the SCell; and/or not transmit PUCCH on the SCell. In an example, reporting CSI for an SCell and not monitoring the PDCCH on/for the SCell, when the SCell is in a dormant state, may provide the base station an always-updated CSI for the SCell. With the always-updated CSI, the base station may employ a quick and/or accurate channel adaptive scheduling on the SCell once the SCell is transitioned back into active state, thereby speeding up the activation procedure of the SCell. In an example, reporting CSI for the SCell and not monitoring the PDCCH on/for the SCell, when the SCell is in dormant state, may improve battery or power consumption of the wireless device, while still providing the base station timely and/or accurate channel information feedback. In an example, a PCell/SPCell and/or a PUCCH secondary cell may not be configured or transitioned into dormant state.

**[0153]** When configured with one or more SCells, a gNB may activate, hibernate, or deactivate at least one of the one or more SCells. In an example, a gNB may transmit one or more RRC messages comprising parameters indicating at least one SCell being set to an active state, a dormant state, or an inactive state, to a wireless device.

**[0154]** In an example, when an SCell is in an active state, the wireless device may perform: SRS transmissions on the SCell; CQI/PMI/RI/CRI reporting for the SCell; PDCCH monitoring on the SCell; PDCCH monitoring for the SCell; and/or PUCCH/SPUCCH transmissions on the SCell.

**[0155]** In an example, when an SCell is in an inactive state, the wireless device may: not transmit SRS on the SCell; not report CQI/PMI/RI/CRI for the SCell; not transmit on UL-SCH on the SCell; not transmit on RACH on the SCell; not monitor PDCCH on the SCell; not monitor PDCCH for the SCell; and/or not transmit PUCCH/SPUCCH on the SCell.

**[0156]** In an example, when an SCell is in a dormant state, the wireless device may: not transmit SRS on the SCell; report CQI/PMI/RI/CRI for the SCell; not transmit on UL-SCH on the SCell; not transmit on RACH on the SCell; not monitor PDCCH on the SCell; not monitor PDCCH for the SCell; and/or not transmit PUCCH/SPUCCH on the SCell.

**[0157]** When configured with one or more SCells, a gNB may activate, hibernate, or deactivate at least one of the one or more SCells. In an example, a gNB may transmit one or more MAC control elements comprising parameters indicating activation, deactivation, or hibernation of at least one SCell to a wireless device.

**[0158]** In an example, a gNB may transmit a first MAC CE (e.g., activation/deactivation MAC CE, as shown in FIG. 20A or FIG. 20B) indicating activation or deactivation of at least one SCell to a wireless device. In FIG. 20A and/or FIG. 20B, a  $C_i$  field may indicate an activation/deactivation status of an SCell with an SCell index  $i$  if an SCell with SCell index  $i$  is configured. In an example, when the  $C_i$  field is set to one, an SCell with an SCell index  $i$  may be activated. In an example, when the  $C_i$  field is set to zero, an SCell with an SCell index  $i$  may be deactivated. In an example, if there is no SCell configured with SCell index  $i$ , the wireless device may ignore the  $C_i$  field. In FIG. 20A and FIG. 20B, an R field may indicate a reserved bit. In an example, the R field may be set to zero.

**[0159]** In an example, a gNB may transmit a second MAC CE (e.g., hibernation MAC CE) indicating activation or

hibernation of at least one SCell to a wireless device. In an example, the second MAC CE may be associated with a second LCID different from a first LCID of the first MAC CE (e.g., activation/deactivation MAC CE). In an example, the second MAC CE may have a fixed size. In an example, the second MAC CE may consist of a single octet containing seven C-fields and one R-field. FIG. 21A shows an example of the second MAC CE with a single octet. In another example, the second MAC CE may consist of four octets containing 31 C-fields and one R-field. FIG. 21B shows an example of the second MAC CE with four octets. In an example, the second MAC CE with four octets may be associated with a third LCID different from the second LCID for the second MAC CE with a single octet, and/or the first LCID for activation/deactivation MAC CE. In an example, when there is no SCell with a serving cell index greater than 7, the second MAC CE of one octet may be applied, otherwise the second MAC CE of four octets may be applied.

**[0160]** In an example, when the second MAC CE is received, and the first MAC CE is not received,  $C_i$  may indicate a dormant/activated status of an SCell with SCell index  $i$  if there is an SCell configured with SCell index  $i$ , otherwise the MAC entity may ignore the  $C_i$  field. In an example, when  $C_i$  is set to "1", the wireless device may transition an SCell associated with SCell index  $i$  into a dormant state. In an example, when  $C_i$  is set to "0", the wireless device may activate an SCell associated with SCell index  $i$ . In an example, when  $C_i$  is set to "0" and the SCell with SCell index  $i$  is in a dormant state, the wireless device may activate the SCell with SCell index  $i$ . In an example, when  $C_i$  is set to "0" and the SCell with SCell index  $i$  is not in a dormant state, the wireless device may ignore the  $C_i$  field.

**[0161]** In an example, when both the first MAC CE (activation/deactivation MAC CE) and the second MAC CE (hibernation MAC CE) are received, two  $C_i$  fields of the two MAC CEs may indicate possible state transitions of the SCell with SCell index  $i$  if there is an SCell configured with SCell index  $i$ , otherwise the MAC entity may ignore the  $C_i$  fields. In an example, the  $C_i$  fields of the two MAC CEs may be interpreted according to FIG. 21C.

**[0162]** When configured with one or more SCells, a gNB may activate, hibernate, or deactivate at least one of the one or more SCells. In an example, a MAC entity of a gNB and/or a wireless device may maintain an SCell deactivation timer (e.g., *sCellDeactivationTimer*) per configured SCell (except the SCell configured with PUCCH/SPUCCH, if any) and deactivate the associated SCell upon its expiry.

**[0163]** In an example, a MAC entity of a gNB and/or a wireless device may maintain an SCell hibernation timer (e.g., *sCellHibernationTimer*) per configured SCell (except the SCell configured with PUCCH/SPUCCH, if any) and hibernate the associated SCell upon the SCell hibernation timer expiry if the SCell is in active state. In an example, when both the SCell deactivation timer and the SCell hibernation timer are configured, the SCell hibernation timer may take priority over the SCell deactivation timer. In an example, when both the SCell deactivation timer and the SCell hibernation timer are configured, a gNB and/or a wireless device may ignore the SCell deactivation timer regardless of the SCell deactivation timer expiry.

**[0164]** In an example, a MAC entity of a gNB and/or a wireless device may maintain a dormant SCell deactivation timer (e.g., *dormantSCellDeactivationTimer*) per configured SCell (except the SCell configured with PUCCH/SPUCCH, if any), and deactivate the associated SCell upon the dormant SCell deactivation timer expiry if the SCell is in dormant state.

**[0165]** In an example, when a MAC entity of a wireless device is configured with an activated SCell upon SCell configuration, the MAC entity may activate the SCell. In an example, when a MAC entity of a wireless device receives a MAC CE(s) activating an SCell, the MAC entity may activate the SCell. In an example, the MAC entity may start or restart the SCell deactivation timer associated with the SCell in response to activating the SCell. In an example, the MAC entity may start or restart the SCell hibernation timer (if configured) associated with the SCell in response to activating the SCell. In an example, the MAC entity may trigger PHR procedure in response to activating the SCell.

**[0166]** In an example, when a MAC entity of a wireless device receives a MAC CE(s) indicating deactivating an SCell, the MAC entity may deactivate the SCell. In an example, in response to receiving the MAC CE(s), the MAC entity may: deactivate the SCell; stop an SCell deactivation timer associated with the SCell; and/or flush all HARQ buffers associated with the SCell.

**[0167]** In an example, when an SCell deactivation timer associated with an activated SCell expires and an SCell hibernation timer is not configured, the MAC entity may: deactivate the SCell; stop the SCell deactivation timer associated with the SCell; and/or flush all HARQ buffers associated with the SCell.

**[0168]** In an example, when a first PDCCH on an activated SCell indicates an uplink grant or downlink assignment, or a second PDCCH on a serving cell scheduling an activated SCell indicates an uplink grant or a downlink assignment for the activated SCell, or a MAC PDU is transmitted in a configured uplink grant or received in a configured downlink assignment, the MAC entity may: restart the SCell deactivation timer associated with the SCell; and/or restart the SCell hibernation timer associated with the SCell if configured. In an example, when an SCell is deactivated, an ongoing random access procedure on the SCell may be aborted.

**[0169]** In an example, when a MAC entity is configured with an SCell associated with an SCell state set to dormant state upon the SCell configuration, or when the MAC entity receives MAC CE(s) indicating transitioning the SCell into a dormant state, the MAC entity may: transition the SCell into a dormant state; transmit one or more CSI reports for the SCell; stop an SCell deactivation timer associated with the SCell; stop an SCell hibernation timer associated with the

SCell if configured; start or restart a dormant SCell deactivation timer associated with the SCell; and/or flush all HARQ buffers associated with the SCell. In an example, when the SCell hibernation timer associated with the activated SCell expires, the MAC entity may: hibernate the SCell; stop the SCell deactivation timer associated with the SCell; stop the SCell hibernation timer associated with the SCell; and/or flush all HARQ buffers associated with the SCell. In an example, when a dormant SCell deactivation timer associated with a dormant SCell expires, the MAC entity may: deactivate the SCell; and/or stop the dormant SCell deactivation timer associated with the SCell. In an example, when an SCell is in dormant state, ongoing random access procedure on the SCell may be aborted.

**[0170]** FIG. 22 shows DCI formats for an example of 20 MHz FDD operation with 2 Tx antennas at the base station and no carrier aggregation in an LTE system. In a NR system, the DCI formats may comprise at least one of: DCI format 0\_0/0\_1 indicating scheduling of PUSCH in a cell; DCI format 1\_0/1\_1 indicating scheduling of PDSCH in a cell; DCI format 2\_0 notifying a group of UEs of slot format; DCI format 2\_1 notifying a group of UEs of PRB(s) and OFDM symbol(s) where a UE may assume no transmission is intended for the UE; DCI format 2\_2 indicating transmission of TPC commands for PUCCH and PUSCH; and/or DCI format 2\_3 indicating transmission of a group of TPC commands for SRS transmission by one or more UEs. In an example, a gNB may transmit a DCI via a PDCCH for scheduling decision and power-control commands. More specifically, the DCI may comprise at least one of: downlink scheduling assignments, uplink scheduling grants, power-control commands. The downlink scheduling assignments may comprise at least one of: PDSCH resource indication, transport format, HARQ information, and control information related to multiple antenna schemes, a command for power control of the PUCCH used for transmission of ACK/NACK in response to downlink scheduling assignments. The uplink scheduling grants may comprise at least one of: PUSCH resource indication, transport format, and HARQ related information, a power control command of the PUSCH.

**[0171]** In an example, the different types of control information correspond to different DCI message sizes. For example, supporting spatial multiplexing with noncontiguous allocation of RBs in the frequency domain may require a larger scheduling message in comparison with an uplink grant allowing for frequency-contiguous allocation only. The DCI may be categorized into different DCI formats, where a format corresponds to a certain message size and usage.

**[0172]** In an example, a UE may monitor one or more PDCCH candidates to detect one or more DCI with one or more DCI format. The one or more PDCCH may be transmitted in common search space or UE-specific search space. A UE may monitor PDCCH with only a limited set of DCI format, to save power consumption. For example, a normal UE may not be required to detect a DCI with DCI format 6 which is used for an eMTC UE. The more DCI format to be detected, the more power be consumed at the UE.

**[0173]** In an example, the one or more PDCCH candidates that a UE monitors may be defined in terms of PDCCH UE-specific search spaces. A PDCCH UE-specific search space at CCE aggregation level  $L \in \{1, 2, 4, 8\}$  may be defined by a set of PDCCH candidates for CCE aggregation level  $L$ . In an example, for a DCI format, a UE may be configured per serving cell by one or more higher layer parameters a number of PDCCH candidates per CCE aggregation level  $L$ .

**[0174]** In an example, in non-DRX mode operation, a UE may monitor one or more PDCCH candidate in control resource set  $q$  according to a periodicity of  $W_{\text{PDCCH},q}$  symbols that may be configured by one or more higher layer parameters for control resource set  $q$ .

**[0175]** In an example, the information in the DCI formats used for downlink scheduling may be organized into different groups, with the field present varying between the DCI formats, including at least one of: resource information, consisting of: carrier indicator (0 or 3bits), RB allocation; HARQ process number; MCS, NDI, and RV (for the first TB); MCS, NDI and RV (for the second TB); MIMO related information; PDSCH resource-element mapping and QCI; Downlink assignment index (DAI); TPC for PUCCH; SRS request (1bit), triggering one-shot SRS transmission; ACK/NACK offset; DCI format 0/1A indication, used to differentiate between DCI format 1A and 0; and padding if necessary. The MIMO related information may comprise at least one of: PMI, precoding information, transport block swap flag, power offset between PDSCH and reference signal, reference-signal scrambling sequence, number of layers, and/or antenna ports for the transmission.

**[0176]** In an example, the information in the DCI formats used for uplink scheduling may be organized into different groups, with the field present varying between the DCI formats, including at least one of: resource information, consisting of: carrier indicator, resource allocation type, RB allocation; MCS, NDI (for the first TB); MCS, NDI (for the second TB); phase rotation of the uplink DMRS; precoding information; CSI request, requesting an aperiodic CSI report; SRS request (2bit), used to trigger aperiodic SRS transmission using one of up to three preconfigured settings; uplink index/DAI; TPC for PUSCH; DCI format 0/1A indication; and padding if necessary.

**[0177]** In an example, a gNB may perform cyclic redundancy check (CRC) scrambling for a DCI, before transmitting the DCI via a PDCCH. The gNB may perform CRC scrambling by bitwise addition (or Modulo-2 addition or exclusive OR (XOR) operation) of multiple bits of at least one wireless device identifier (e.g., C-RNTI, CS-RNTI, TPC-CS-RNTI, TPC-PUCCH-RNTI, TPC-PUSCH-RNTI, SP CSI C-RNTI, SRS-TPC-RNTI, INT-RNTI, SFI-RNTI, P-RNTI, SI-RNTI, RA-RNTI, and/or MCS-C-RNTI) with the CRC bits of the DCI. The wireless device may check the CRC bits of the DCI, when detecting the DCI. The wireless device may receive the DCI when the CRC is scrambled by a sequence of bits that is the same as the at least one wireless device identifier.

**[0178]** In a NR system, in order to support wide bandwidth operation, a gNB may transmit one or more PDCCH in different control resource sets. A gNB may transmit one or more RRC message comprising configuration parameters of one or more control resource sets. At least one of the one or more control resource sets may comprise at least one of: a first OFDM symbol; a number of consecutive OFDM symbols; a set of resource blocks; a CCE-to-REG mapping; and a REG bundle size, in case of interleaved CCE-to-REG mapping.

**[0179]** A base station (gNB) may configure a wireless device (UE) with uplink (UL) bandwidth parts (BWPs) and downlink (DL) BWPs to enable bandwidth adaptation (BA) on a PCell. If carrier aggregation is configured, the gNB may further configure the UE with at least DL BWP(s) (e.g., there may be no UL BWPs in the UL) to enable BA on an SCell. For the PCell, an initial active BWP may be a first BWP used for initial access. For the SCell, a first active BWP may be a second BWP configured for the UE to operate on the SCell upon the SCell being activated.

**[0180]** In paired spectrum (e.g. FDD), a gNB and/or a UE may independently switch a DL BWP and an UL BWP. In unpaired spectrum (e.g. TDD), a gNB and/or a UE may simultaneously switch a DL BWP and an UL BWP.

**[0181]** In an example, a gNB and/or a UE may switch a BWP between configured BWPs by means of a DCI or a BWP inactivity timer. When the BWP inactivity timer is configured for a serving cell, the gNB and/or the UE may switch an active BWP to a default BWP in response to an expiry of the BWP inactivity timer associated with the serving cell. The default BWP may be configured by the network.

**[0182]** In an example, for FDD systems, when configured with BA, one UL BWP for each uplink carrier and one DL BWP may be active at a time in an active serving cell. In an example, for TDD systems, one DL/UL BWP pair may be active at a time in an active serving cell. Operating on the one UL BWP and the one DL BWP (or the one DL/UL pair) may improve UE battery consumption. BWPs other than the one active UL BWP and the one active DL BWP that the UE may work on may be deactivated. On deactivated BWPs, the UE may: not monitor PDCCH; and/or not transmit on PUCCH, PRACH, and UL-SCH.

**[0183]** In an example, a serving cell may be configured with at most a first number (e.g., four) of BWPs. In an example, for an activated serving cell, there may be one active BWP at any point in time.

**[0184]** In an example, a BWP switching for a serving cell may be used to activate an inactive BWP and deactivate an active BWP at a time. In an example, the BWP switching may be controlled by a PDCCH indicating a downlink assignment or an uplink grant. In an example, the BWP switching may be controlled by a BWP inactivity timer (e.g., *bwp-Inactivity-Timer*). In an example, the BWP switching may be controlled by a MAC entity in response to initiating a Random Access procedure. Upon addition of an SpCell or activation of an SCell, one BWP may be initially active without receiving a PDCCH indicating a downlink assignment or an uplink grant. The active BWP for a serving cell may be indicated by RRC and/or PDCCH. In an example, for unpaired spectrum, a DL BWP may be paired with a UL BWP, and BWP switching may be common for both UL and DL.

**[0185]** FIG. 23 shows an example of BWP switching on an SCell. In an example, a UE may receive RRC message comprising parameters of a SCell and one or more BWP configuration associated with the SCell. The RRC message may comprise: RRC connection reconfiguration message (e.g., *RRCReconfiguration*); RRC connection reestablishment message (e.g., *RRCReestablishment*); and/or RRC connection setup message (e.g., *RRCSetup*). Among the one or more BWPs, at least one BWP may be configured as the first active BWP (e.g., BWP 1 in FIG. 23), one BWP as the default BWP (e.g., BWP 0 in FIG. 23). The UE may receive a MAC CE to activate the SCell at  $n^{\text{th}}$  slot. The UE may start a SCell deactivation timer (e.g., *sCellDeactivationTimer*), and start CSI related actions for the SCell, and/or start CSI related actions for the first active BWP of the SCell. The UE may start monitoring a PDCCH on BWP 1 in response to activating the SCell.

**[0186]** In an example, the UE may start restart a BWP inactivity timer (e.g., *bwp-InactivityTimer*) at  $m^{\text{th}}$  slot in response to receiving a DCI indicating DL assignment on BWP 1. The UE may switch back to the default BWP (e.g., BWP 0) as an active BWP when the BWP inactivity timer expires, at  $s^{\text{th}}$  slot. The UE may deactivate the SCell and/or stop the BWP inactivity timer when the *sCellDeactivationTimer* expires.

**[0187]** Employing the BWP inactivity timer may further reduce UE's power consumption when the UE is configured with multiple cells with each cell having wide bandwidth (e.g., 1 GHz). The UE may only transmit on or receive from a narrow-bandwidth BWP (e.g., 5MHz) on the PCell or SCell when there is no activity on an active BWP.

**[0188]** In an example, a MAC entity may apply normal operations on an active BWP for an activated serving cell configured with a BWP comprising: transmitting on UL-SCH; transmitting on RACH; monitoring a PDCCH; transmitting PUCCH; receiving DL-SCH; and/or (re-) initializing any suspended configured uplink grants of configured grant Type 1 according to a stored configuration, if any.

**[0189]** In an example, on an inactive BWP for each activated serving cell configured with a BWP, a MAC entity may: not transmit on UL-SCH; not transmit on RACH; not monitor a PDCCH; not transmit PUCCH; not transmit SRS, not receive DL-SCH; clear any configured downlink assignment and configured uplink grant of configured grant Type 2; and/or suspend any configured uplink grant of configured Type 1.

**[0190]** In an example, if a MAC entity receives a PDCCH for a BWP switching of a serving cell while a Random Access procedure associated with this serving cell is not ongoing, a UE may perform the BWP switching to a BWP indicated by

the PDCCH.

**[0191]** In an example, if a bandwidth part indicator field is configured in DCI format 1\_1, the bandwidth part indicator field value may indicate the active DL BWP, from the configured DL BWP set, for DL receptions. In an example, if a bandwidth part indicator field is configured in DCI format 0\_1, the bandwidth part indicator field value may indicate the active UL BWP, from the configured UL BWP set, for UL transmissions.

**[0192]** In an example, for a primary cell, a UE may be provided by a higher layer parameter Default-DL-BWP a default DL BWP among the configured DL BWPs. If a UE is not provided a default DL BWP by the higher layer parameter Default-DL-BWP, the default DL BWP is the initial active DL BWP.

**[0193]** In an example, a UE may be provided by higher layer parameter *bwp-InactivityTimer*, a timer value for the primary cell. If configured, the UE may increment the timer, if running, every interval of 1 millisecond for frequency range 1 or every 0.5 milliseconds for frequency range 2 if the UE may not detect a DCI format 1\_1 for paired spectrum operation or if the UE may not detect a DCI format 1\_1 or DCI format 0\_1 for unpaired spectrum operation during the interval.

**[0194]** In an example, if a UE is configured for a secondary cell with higher layer parameter Default-DL-BWP indicating a default DL BWP among the configured DL BWPs and the UE is configured with higher layer parameter *bwp-InactivityTimer* indicating a timer value, the UE procedures on the secondary cell may be same as on the primary cell using the timer value for the secondary cell and the default DL BWP for the secondary cell.

**[0195]** In an example, if a UE is configured by higher layer parameter Active-BWP-DL-SCell a first active DL BWP and by higher layer parameter Active-BWP-UL-SCell a first active UL BWP on a secondary cell or carrier, the UE may use the indicated DL BWP and the indicated UL BWP on the secondary cell as the respective first active DL BWP and first active UL BWP on the secondary cell or carrier.

**[0196]** In an example, a wireless device may transmit one or more uplink control information (UCI) via one or more PUCCH resources to a base station. The one or more UCI may comprise at least one of: HARQ-ACK information; scheduling request (SR); and/or CSI report. In an example, a PUCCH resource may be identified by at least: frequency location (e.g., starting PRB); and/or a PUCCH format associated with initial cyclic shift of a base sequence and time domain location (e.g., starting symbol index). In an example, a PUCCH format may be PUCCH format 0, PUCCH format 1, PUCCH format 2, PUCCH format 3, or PUCCH format 4. A PUCCH format 0 may have a length of 1 or 2 OFDM symbols and be less than or equal to 2 bits. A PUCCH format 1 may occupy a number between 4 and 14 of OFDM symbols and be less than or equal to 2 bits. A PUCCH format 2 may occupy 1 or 2 OFDM symbols and be greater than 2 bits. A PUCCH format 3 may occupy a number between 4 and 14 of OFDM symbols and be greater than 2 bits. A PUCCH format 4 may occupy a number between 4 and 14 of OFDM symbols and be greater than 2 bits. The PUCCH resource may be configured on a PCell, or a PUCCH secondary cell.

**[0197]** In an example, when configured with multiple uplink BWPs, a base station may transmit to a wireless device, one or more RRC messages comprising configuration parameters of one or more PUCCH resource sets (e.g., at most 4 sets) on an uplink BWP of the multiple uplink BWPs. Each PUCCH resource set may be configured with a PUCCH resource set index, a list of PUCCH resources with each PUCCH resource being identified by a PUCCH resource identifier (e.g., *pucch-Resourceid*), and/or a maximum number of UCI information bits a wireless device may transmit using one of the plurality of PUCCH resources in the PUCCH resource set.

**[0198]** In an example, when configured with one or more PUCCH resource sets, a wireless device may select one of the one or more PUCCH resource sets based on a total bit length of UCI information bits (e.g., HARQ-ARQ bits, SR, and/or CSI) the wireless device will transmit. In an example, when the total bit length of UCI information bits is less than or equal to 2, the wireless device may select a first PUCCH resource set with the PUCCH resource set index equal to "0". In an example, when the total bit length of UCI information bits is greater than 2 and less than or equal to a first configured value, the wireless device may select a second PUCCH resource set with the PUCCH resource set index equal to "1". In an example, when the total bit length of UCI information bits is greater than the first configured value and less than or equal to a second configured value, the wireless device may select a third PUCCH resource set with the PUCCH resource set index equal to "2". In an example, when the total bit length of UCI information bits is greater than the second configured value and less than or equal to a third value (e.g., 1706), the wireless device may select a fourth PUCCH resource set with the PUCCH resource set index equal to "3".

**[0199]** In an example, a wireless device may determine, based on a number of uplink symbols of UCI transmission and a number of UCI bits, a PUCCH format from a plurality of PUCCH formats comprising PUCCH format 0, PUCCH format 1, PUCCH format 2, PUCCH format 3 and/or PUCCH format 4. In an example, the wireless device may transmit UCI in a PUCCH using PUCCH format 0 if the transmission is over 1 symbol or 2 symbols and the number of HARQ-ACK information bits with positive or negative SR (HARQ-ACK/SR bits) is 1 or 2. In an example, the wireless device may transmit UCI in a PUCCH using PUCCH format 1 if the transmission is over 4 or more symbols and the number of HARQ-ACK/SR bits is 1 or 2. In an example, the wireless device may transmit UCI in a PUCCH using PUCCH format 2 if the transmission is over 1 symbol or 2 symbols and the number of UCI bits is more than 2. In an example, the wireless device may transmit UCI in a PUCCH using PUCCH format 3 if the transmission is over 4 or more symbols, the number of UCI bits is more than 2 and PUCCH resource does not include an orthogonal cover code. In an example, the wireless

device may transmit UCI in a PUCCH using PUCCH format 4 if the transmission is over 4 or more symbols, the number of UCI bits is more than 2 and the PUCCH resource includes an orthogonal cover code.

**[0200]** In an example, in order to transmit HARQ-ACK information on a PUCCH resource, a wireless device may determine the PUCCH resource from a PUCCH resource set. The PUCCH resource set may be determined as mentioned above. The wireless device may determine the PUCCH resource based on a PUCCH resource indicator field in a DCI (e.g., with a DCI format 1\_0 or DCI for 1\_1) received on a PDCCH. A 3-bit PUCCH resource indicator field in the DCI may indicate one of eight PUCCH resources in the PUCCH resource set. The wireless device may transmit the HARQ-ACK information in a PUCCH resource indicated by the 3-bit PUCCH resource indicator field in the DCI.

**[0201]** In an example, the wireless device may transmit one or more UCI bits via a PUCCH resource of an active uplink BWP of a PCell or a PUCCH secondary cell. Since at most one active uplink BWP in a cell is supported for a wireless device, the PUCCH resource indicated in the DCI is naturally a PUCCH resource on the active uplink BWP of the cell.

**[0202]** In an example, DRX operation may be used by a wireless device (UE) to improve UE battery lifetime. In an example, in DRX, UE may discontinuously monitor downlink control channel, e.g., PDCCH or EPDCCH. In an example, the base station may configure DRX operation with a set of DRX parameters, e.g., using RRC configuration. The set of DRX parameters may be selected based on the application type such that the wireless device may reduce power and resource consumption. In an example, in response to DRX being configured/activated, a UE may receive data packets with an extended delay, since the UE may be in DRX Sleep/Off state at the time of data arrival at the UE and the base station may wait until the UE transitions to the DRX ON state.

**[0203]** In an example, during a DRX mode, the UE may power down most of its circuitry when there are no packets to be received. The UE may monitor PDCCH discontinuously in the DRX mode. The UE may monitor the PDCCH continuously when a DRX operation is not configured. During this time the UE listens to the downlink (DL) (or monitors PDCCHs) which is called DRX Active state. In a DRX mode, a time during which UE doesn't listen/monitor PDCCH is called DRX Sleep state.

**[0204]** FIG. 24 shows an example of the embodiment. A gNB may transmit an RRC message comprising one or more DRX parameters of a DRX cycle. The one or more parameters may comprise a first parameter and/or a second parameter. The first parameter may indicate a first time value of the DRX Active state (e.g., DRX On duration) of the DRX cycle. The second parameter may indicate a second time of the DRX Sleep state (e.g., DRX Off duration) of the DRX cycle. The one or more parameters may further comprise a time duration of the DRX cycle. During the DRX Active state, the UE may monitor PDCCHs for detecting one or more DCIs on a serving cell. During the DRX Sleep state, the UE may stop monitoring PDCCHs on the serving cell. When multiple cells are in active state, the UE may monitor all PDCCHs on (or for) the multiple cells during the DRX Active state. During the DRX off duration, the UE may stop monitoring all PDCCH on (or for) the multiple cells. The UE may repeat the DRX operations according to the one or more DRX parameters.

**[0205]** In an example, DRX may be beneficial to the base station. In an example, if DRX is not configured, the wireless device may be transmitting periodic CSI and/or SRS frequently (e.g., based on the configuration). With DRX, during DRX OFF periods, the UE may not transmit periodic CSI and/or SRS. The base station may assign these resources to the other UEs to improve resource utilization efficiency.

**[0206]** In an example, the MAC entity may be configured by RRC with a DRX functionality that controls the UE's downlink control channel (e.g., PDCCH) monitoring activity for a plurality of RNTIs for the MAC entity. The plurality of RNTIs may comprise at least one of: C-RNTI; CS-RNTI; INT-RNTI; SP-CSI-RNTI; SFI-RNTI; TPC-PUCCH-RNTI; TPC-PUSCH-RNTI; Semi-Persistent Scheduling C-RNTI; eIMTA-RNTI; SL-RNTI; SL-V-RNTI; CC-RNTI; or SRS-TPC-RNTI. In an example, in response to being in RRC\_CONNECTED, if DRX is configured, the MAC entity may monitor the PDCCH discontinuously using the DRX operation; otherwise the MAC entity may monitor the PDCCH continuously.

**[0207]** In an example, RRC may control DRX operation by configuring a plurality of timers. The plurality of timers may comprise: a DRX On duration timer (e.g., *drx-onDurationTimer*); a DRX inactivity timer (e.g., *drx-InactivityTimer*); a downlink DRX HARQ RTT timer (e.g., *drx-HARQ-RTT-TimerDL*); an uplink DRX HARQ RTT Timer (e.g., *drx-HARQ-RTT-TimerUL*); a downlink retransmission timer (e.g., *drx-RetransmissionTimerDL*); an uplink retransmission timer (e.g., *drx-RetransmissionTimerUL*); one or more parameters of a short DRX configuration (e.g., *drx-ShortCycle* and/or *drx-ShortCycleTimer*) and one or more parameters of a long DRX configuration (e.g., *drx-LongCycle*). In an example, time granularity for DRX timers may be in terms of PDCCH subframes (e.g., indicated as psf in the DRX configurations), or in terms of milliseconds.

**[0208]** In an example, in response to a DRX cycle being configured, the Active Time may include the time while at least one timer is running. The at least one timer may comprise *drx-onDurationTimer*, *drx-InactivityTimer*, *drx-RetransmissionTimerDL*, *drx-RetransmissionTimerUL*, or *mac-ContentionResolutionTimer*.

**[0209]** In an example, *drx-Inactivity-Timer* may specify a time duration for which the UE may be active after successfully decoding a PDCCH indicating a new transmission (UL or DL or SL). In an example, this timer may be restarted upon receiving PDCCH for a new transmission (UL or DL or SL). In an example, the UE may transition to a DRX mode (e.g., using a short DRX cycle or a long DRX cycle) in response to the expiry of this timer.

**[0210]** In an example, *drx-ShortCycle* may be a first type of DRX cycle (e.g., if configured) that needs to be followed when UE enters DRX mode. In an example, a DRX-Config IE indicates the length of the short cycle.

**[0211]** In an example, *drx-ShortCycleTimer* may be expressed as multiples of shortDRX-Cycle. The timer may indicate the number of initial DRX cycles to follow the short DRX cycle before entering the long DRX cycle.

**[0212]** In an example, *drx-onDurationTimer* may specify the time duration at the beginning of a DRX Cycle (e.g., DRX ON). In an example, *drx-onDurationTimer* may indicate the time duration before entering the sleep mode (DRX OFF).

**[0213]** In an example, *drx-HARQ-RTT-TimerDL* may specify a minimum duration from the time new transmission is received and before the UE may expect a retransmission of a same packet. In an example, this timer may be fixed and may not be configured by RRC.

**[0214]** In an example, *drx-RetransmissionTimerDL* may indicate a maximum duration for which UE may be monitoring PDCCH when a retransmission from the eNodeB is expected by the UE.

**[0215]** In an example, in response to a DRX cycle being configured, the Active Time may comprise the time while a Scheduling Request is sent on PUCCH and is pending.

**[0216]** In an example, in response to a DRX cycle being configured, the Active Time may comprise the time while an uplink grant for a pending HARQ retransmission may occur and there is data in the corresponding HARQ buffer for synchronous HARQ process.

**[0217]** In an example, in response to a DRX cycle being configured, the Active Time may comprise the time while a PDCCH indicating a new transmission addressed to the C-RNTI of the MAC entity has not been received after successful reception of a Random Access Response for the preamble not selected by the MAC entity.

**[0218]** In an example, DRX may be configured for a wireless device. A DL HARQ RTT Timer may expire in a subframe and the data of the corresponding HARQ process may not be successfully decoded. The MAC entity may start the *drx-RetransmissionTimerDL* for the corresponding HARQ process.

**[0219]** In an example, DRX may be configured for a wireless device. An UL HARQ RTT Timer may expire in a subframe. The MAC entity may start the *drx-RetransmissionTimerUL* for the corresponding HARQ process.

**[0220]** In an example, DRX may be configured for a wireless device. A DRX Command MAC control element or a Long DRX Command MAC control element may be received. The MAC entity may stop *drx-onDurationTimer* and stop *drx-InactivityTimer*.

**[0221]** In an example, DRX may be configured for a wireless device. In an example, *drx-InactivityTimer* may expire or a DRX Command MAC control element may be received in a subframe. In an example, in response to Short DRX cycle being configured, the MAC entity may start or restart *drx-ShortCycleTimer* and may use Short DRX Cycle. Otherwise, the MAC entity may use the Long DRX cycle.

**[0222]** In an example, DRX may be configured for a wireless device. In an example, *drx-ShortCycleTimer* may expire in a subframe. The MAC entity may use the Long DRX cycle.

**[0223]** In an example, DRX may be configured for a wireless device. In an example, a Long DRX Command MAC control element may be received. The MAC entity may stop *drx-ShortCycleTimer* and may use the Long DRX cycle.

**[0224]** In an example, DRX may be configured for a wireless device. In an example, if the Short DRX Cycle is used and  $[(SFN * 10) + \text{subframe number}] \bmod (drx-ShortCycle) = (drxStartOffset) \bmod (drx-ShortCycle)$ , the wireless device may start *drx-onDurationTimer*.

**[0225]** In an example, DRX may be configured for a wireless device. In an example, if the Long DRX Cycle is used and  $[(SFN * 10) + \text{subframe number}] \bmod (drx-longCycle) = drxStartOffset$ , the wireless device may start *drx-onDurationTimer*.

**[0226]** FIG. 25 shows example of DRX operation in a legacy system. A base station may transmit an RRC message comprising configuration parameters of DRX operation. A base station may transmit a DCI for downlink resource allocation via a PDCCH, to a UE. the UE may start the *drx-InactivityTimer* during which, the UE may monitor the PDCCH. After receiving a transmission block (TB) when the *drx-InactivityTimer* is running, the UE may start a HARQ RTT Timer (e.g., *drx-HARQ-RTT-TimerDL*), during which, the UE may stop monitoring the PDCCH. The UE may transmit a NACK to the base station upon unsuccessful receiving the TB. When the HARQ RTT Timer expires, the UE may monitor the PDCCH and start a HARQ retransmission timer (e.g., *drx-RetransmissionTimerDL*). When the HARQ retransmission timer is running, the UE may receive a second DCI indicating a DL grant for the retransmission of the TB. If not receiving the second DCI before the HARQ retransmission timer expires, the UE may stop monitoring the PDCCH.

**[0227]** In an LTE/LTE-A or 5G system, when configured with DRX operation, a UE may monitor PDCCH for detecting one or more DCIs during the DRX Active time of a DRX cycle. The UE may stop monitoring PDCCH during the DRX sleep/Off time of the DRX cycle, to save power consumption. In some cases, the UE may fail to detect the one or more DCIs during the DRX Active time, since the one or more DCIs are not addressed to the UE. For example, a UE may be an URLLC UE, or a NB-IoT UE, or an MTC UE. The UE may not always have data to be received from a gNB, in which case, waking up to monitor PDCCH in the DRX active time may result in useless power consumption. A wake-up mechanism combined with DRX operation may be used to further reduce power consumption specifically in a DRX active time. FIG. 26A and FIG. 26B show examples of the wake-up mechanism.

[0228] In FIG. 26A, a gNB may transmit one or more messages comprising parameters of a wake-up duration (or a power saving duration), to a UE. The wake-up duration may be located a number of slots (or symbols) before a DRX On duration of a DRX cycle. The number of slots (or symbols), or, referred to as a gap between a wakeup duration and a DRX on duration, may be configured in the one or more RRC messages or predefined as a fixed value. The gap may be used for at least one of: synchronization with the gNB; measuring reference signals; and/or retuning RF parameters. The gap may be determined based on a capability of the UE and/or the gNB. In an example, the wake-up mechanism may be based on a wake-up signal. The parameters of the wake-up duration may comprise at least one of: a wake-up signal format (e.g., numerology, sequence length, sequence code, etc.); a periodicity of the wake-up signal; a time duration value of the wake-up duration; a frequency location of the wake-up signal. In LTE Re.15 specification, the wake-up signal for paging may comprise a signal sequence (e.g., Zadoff-Chu sequence) generated based on a cell identification

(e.g., cell ID) as:  $w(m) = \theta_{n_f, n_s}(m) \cdot e^{-\frac{j\pi un(n+1)}{131}}$ . In the example,  $m = 0, 1, \dots, 132M - 1$ , and  $n = m \bmod 132$ .

$$\theta_{n_f, n_s}(m) = \begin{cases} 1, & \text{if } c_{n_f, n_s}(2m) = 0 \text{ and } c_{n_f, n_s}(2m + 1) = 0 \\ -1, & \text{if } c_{n_f, n_s}(2m) = 0 \text{ and } c_{n_f, n_s}(2m + 1) = 1 \\ j, & \text{if } c_{n_f, n_s}(2m) = 1 \text{ and } c_{n_f, n_s}(2m + 1) = 0 \\ -j, & \text{if } c_{n_f, n_s}(2m) = 1 \text{ and } c_{n_f, n_s}(2m + 1) = 1 \end{cases}$$

[0229] In an example,

$u = (N_{ID}^{cell} \bmod 126) + 3 \cdot N_{ID}^{cell}$  may be a cell ID of the serving cell.  $M$  may be a number of subframes in which the WUS may be transmitted,  $1 \leq M \leq M_{WUSmax}$ , where  $M_{WUSmax}$  is the maximum number of subframes in which the WUS may be transmitted.  $c_{n_f, n_s}(i)$ ,  $i = 0, 1, \dots, 2 \cdot 132M - 1$  may be a scrambling sequence (e.g., a length-31 Gold sequence), which may be initialized at start of transmission of the WUS with:

$c_{init\_WUS} = (N_{ID}^{cell} + 1) \left( \left( 10n_{f\_start\_PO} + \left\lfloor \frac{n_{s\_start\_PO}}{2} \right\rfloor \right) \bmod 2048 + 1 \right) 2^9 + N_{ID}^{cell}$ , where  $n_{f\_start\_PO}$  is the first frame of a first paging occasion to which the WUS is associated, and  $n_{s\_start\_PO}$  is a first slot of the first paging occasion to which the WUS is associated.

[0230] In an example, the parameters of the wake-up duration may be pre-defined without RRC configuration. In an example, the wake-up mechanism may be based on a wake-up channel (e.g., a PDCCH, or a DCI). The parameters of the wake-up duration may comprise at least one of: a wake-up channel format (e.g., numerology, DCI format, PDCCH format); a periodicity of the wake-up channel; a control resource set and/or a search space of the wake-up channel. When configured with the parameters of the wake-up duration, the UE may monitor the wake-up signal or the wake-up channel during the wake-up duration. A UE may monitor the wake-up signal or the wake-up channel during a first few slots of DRX OnDuration. In response to receiving the wake-up signal/channel, the UE may wake-up to monitor PDCCHs as expected according to the DRX configuration. In an example, in response to receiving the wake-up signal/channel, the UE may monitor PDCCHs in the DRX active time (e.g., when *drx-onDurationTimer* is running). The UE may go back to sleep if not receiving PDCCHs in the DRX active time. The UE may keep in sleep during the DRX off duration of the DRX cycle. In an example, if the UE doesn't receive the wake-up signal/channel during the wake-up duration, the UE may skip monitoring PDCCHs during the DRX active time. This mechanism may reduce power consumption for PDCCH monitoring during the DRX active time. The wake-up signal/channel may comprise a list of power states, a power state for a cell. The UE may transition to the indicated power state of the cell in response to the wake-up signal/channel. In the example, during the wake-up duration, a UE may monitor the wake-up signal/channel only. During the DRX off duration, the UE may stop monitoring PDCCHs and the wake-up signal/channel. During the DRX active duration, the UE may monitor PDCCHs except of the wake-up signal/channel, if receiving the wake-up signal/channel in the wake-up duration. In an example, the gNB and/or the UE may apply the wake-up mechanism in paging operation when the UE is in an RRC\_idle state or an RRC\_inactive state, or in a connected DRX operation (C-DRX) when the UE is in an RRC\_CONNECTED state.

[0231] In an example, a wake-up mechanism may be based on a go-to-sleep signal/channel. FIG. 26B shows an example. A gNB may transmit one or more messages comprising parameters of a wake-up duration (or a power saving duration), to a UE. The one or more messages may comprise at least one RRC message. The at least one RRC message may comprise one or more cell-specific or cell-common RRC messages (e.g., *ServingCellConfig* IE, *ServingCellConfigCommon* IE, *MAC-CellGroupConfig* IE). The wake-up duration may be located a number of slots (or symbols) before a DRX On duration of a DRX cycle. The number of slots (or symbols) may be configured in the one or more RRC messages or predefined as a fixed value. In an example, the wake-up mechanism may be based on a go-to-sleep signal. The parameters of the wake-up duration may comprise at least one of: a go-to-sleep signal format (e.g., numerology,

sequence length, sequence code, etc.); a periodicity of the go-to-sleep signal; a time duration value of the wake-up duration; a frequency location of the go-to-sleep signal. In an example, the wake-up mechanism may be based on a go-to-sleep channel (e.g., a PDCCH, or a DCI). The parameters of the wake-up duration may comprise at least one of: a go-to-sleep channel format (e.g., numerology, DCI format, PDCCH format); a periodicity of the go-to-sleep channel; a control resource set and/or a search space of the go-to-sleep channel. When configured with the parameters of the wake-up duration, the UE may monitor the go-to-sleep signal or the go-to-sleep channel during the wake-up duration. A UE may monitor the go-to-sleep signal or the wake-up channel during a first few slots of DRX OnDuration. In response to receiving the go-to-sleep signal/channel, the UE may go back to sleep and skip monitoring PDCCHs during the DRX active time. The go-to-sleep signal/channel may comprise a list of power states, a power state for a cell. The UE may transition to the indicated power state of the cell in response to the wake-up signal/channel. In an example, if the UE doesn't receive the go-to-sleep signal/channel during the wake-up duration, the UE may monitor PDCCHs during the DRX active time. This mechanism may reduce power consumption for PDCCH monitoring during the DRX active time. In an example, compared with a wake-up signal based wake-up mechanism, a go-to-sleep signal based mechanism may be more robust to detection error. If the UE miss detects the go-to-sleep signal, the consequence is that the UE may wrongly start monitoring PDCCH, which may result in extra power consumption. However, if the UE miss detects the wake-up signal, the consequence is that the UE may miss a DCI which may be addressed to the UE. In the case, missing the DCI may result in communication interruption. In some cases (e.g., URLLC service or V2X service), the UE and/or the gNB may not allow communication interruption compared with extra power consumption.

**[0232]** In existing technologies, a base station may transmit one or more medium access control (MAC) control element (CE) messages comprising a plurality of bits, wherein each bit of the plurality of bits corresponds to a cell of one or more secondary serving cells, indicating transitions of the one or more secondary serving cells between a dormant state and a normal state (e.g., a non-dormant state) to a wireless device. In response to receiving the one or more MAC CE messages, the wireless device may determine whether to transition between the dormant state and the normal state for the one or more secondary serving cells. Existing mechanisms based on the one or more MAC CE messages may not be efficient with high resource overhead and large transition latency. For example, the base station may need to transmit at least one DCI comprising a resource assignment for a PDSCH and transmit, in the resources of the resource assignment, the one or more MAC CEs carried via the PDSCH. The wireless device may need to receive the at least one DCI and the PDSCH to be able to receive the one or more MAC CEs. Existing mechanisms may not be scalable with large latency and high overhead, when frequent transitions between the dormant state and the normal state occur and/or a large number of serving cells is configured to the wireless device. To achieve effective UE power saving without performance degradation, enhancements to allow a fast, dynamic and scalable transitions of serving cells between different power states are necessary.

**[0233]** In an example, a base station may transmit one or more radio resource control (RRC) messages to a wireless device. The one or more RRC messages may comprise configuration parameters. The configuration parameters may indicate/comprise a first secondary cell (SCell) group comprising one or more first cells and a second SCell group comprising a plurality of second cells. The base station may configure a plurality of serving cells to the wireless device, wherein the plurality of serving cells may comprise the one or more first cells and the plurality of second cells. The wireless device may activate, in a non-dormant state, the one or more first cells and the plurality of second cells. The base station may determine the first SCell group of the one or more first cells, wherein each cell of the one or more first cells may operate in a first frequency band and/or a first frequency band combination. The base station may determine the second SCell group of the plurality of second cells, wherein each cell of the plurality of second cells may operate in a second frequency band and/or a second frequency band combination. The wireless device may share one or more first radio frequency (RF) resources (e.g., radio frequency equipment, antennas, baseband processor, transceiver/receiver, and/or the like) for the one or more first cells. The wireless device may share one or more second RF resources for the plurality of second cells. When a first cell of the one or more first cells is in a dormant state whereas a second cell of the one or more first cells is in a normal state, the wireless device may not be able to turn off or reduce power consumptions significantly on the one or more first RF resources.

**[0234]** In an example, to enable enhanced power saving of the wireless device, the base station may transition the one or more first cells as a whole between the dormant state and the normal state. The base station may transition the plurality of second cells as a whole between the power states. The base station may transmit a DCI indicating transitioning the first SCell group to a dormant state. The wireless device, in response to receiving the DCI, may transition the one or more first cells to the dormant state. The wireless device, in response to the receiving the DCI, may maintain the plurality of second cells in the non-dormant state.

**[0235]** A grouping of serving cells in to a few SCell groups may allow low overhead in signaling and enhance power saving of the wireless device. With reduced signaling overhead, an indication of transitioning one or more serving cells between a dormant state and a normal state may be introduced in a dynamic signaling such as a DCI, a scheduling DCI, a group-common DCI, and/or the like. The reduced signaling overhead by the grouping may allow fast, dynamic and scalable transitioning mechanism.

**[0236]** In existing technologies, a wireless device may stop monitoring a DCI comprising a resource assignment of a first cell, in response to a command indicating that the first cell transitions to a dormant state (e.g., a dormant SCell). For example, the wireless device may monitor a first DCI, wherein the first DCI comprises a resource assignment for the first cell, on one or more first CORESETs on the first cell, when a self-carrier scheduling is configured for the first cell. For example, the wireless device may monitor a second DCI, wherein the second DCI may comprises a resource assignment for the first cell, on one or more second CORESETs on a second cell when a cross-carrier scheduling is configured for the first cell with the second cell as a scheduling cell for the first cell. The wireless device may stop monitoring for the first DCI on the one or more first CORESETs of the first cell (e.g., self-carrier scheduling) or stop monitoring for the second DCI on the one or more second CORESETs of the second cell (e.g., cross-carrier scheduling) in response to the first cell being switched/transitioned to the dormant state. A base station may need to transmit another signaling, which may be another DCI or a MAC-CE signaling, to wake-up/transition the first cell from the dormant state. Implementation of existing technologies based on one or more MAC CE messages may utilize more resources to transmit additional signaling related to power saving/dormant state. The network may need to add more resources as the number of dormant cells becomes larger. There is a need for an enhanced monitoring mechanism on a DCI to wake-up a cell from a dormant state.

**[0237]** FIG. 27 illustrates an example of an embodiment. In FIG. 27, a wireless device may monitor a DCI comprising a resource assignment for a first cell (e.g. Cell 1) on one or more second CORESETs of a second cell (e.g. Cell 0), wherein the DCI may indicate transitioning/waking-up the first cell from a dormant state to a normal state. The DCI may schedule downlink scheduling or uplink grant for the first cell. The DCI may indicate the wake-up command for the first cell and/or the transition to the normal state from the dormant state of the first cell. The DCI may comprise the resource assignment for the first cell and the wake-up/transition command. This may reduce additional overhead to transmit additional signaling to wake-up dormant cells or to transition one or more cells from the dormant state to the normal state. This may reduce the latency to receive a scheduling DCI on the dormant cell.

**[0238]** In FIG. 27, the wireless device may monitor for a first DCI via one or more first CORESETs of a first cell (Cell 1), wherein the first cell is in a second power state (e.g., normal state or non-dormant state). For example, as shown in FIG. 27, the one or more first CORESETs comprises SS1/CORESET1, SS2/CORESET2, and SSn/CORESETn of a BWP (BPW1) of the first cell (Cell 1). The wireless device may monitor for a second DCI via the one or more second CORESETs of the second cell (Cell 0), wherein the first cell is in a first power state (e.g., a power saving state, dormant state). For example, as shown in FIG. 27, the one or more second CORESETs comprises SS1/CORESET1 and SSk/CORESETk of a BWP (BPW0) of the second cell (Cell 0). The wireless device may monitor for a DCI comprising a resource assignment for the first cell via the one or more first CORESETs of the first cell or the one or more second CORESETs of the second cell based on a power state of the first cell (e.g., a normal state or a dormant state). The wireless device may receive the first DCI, transmitted via the one or more first CORESETs. The first DCI may comprise a resource assignment for the first cell and may indicate a transition from the second power state to the first power state for the first cell. The first DCI may indicate the transition from the second power state to the first power state without comprising the resource assignment for the first cell. In response to the first DCI, the wireless device may transition the first cell from the second power state to the first power state. The first cell may be in the dormant state. The wireless device may receive the second DCI, transmitted via the one or more second CORESETs of the second cell, for the first cell. The second DCI may comprise a resource assignment for the first cell and may indicate transition from the first power state to the second power state for the first cell. The second DCI may indicate the transition from the first power state to the second power state without comprising the resource assignment for the first cell. The second DCI may comprise a first bandwidth part index for the first cell. The wireless device may switch to the first BWP of the first cell in response to receiving the second DCI. The wireless device may monitor for a third DCI comprising a resource assignment for the first cell on one or more third CORESETs in response to receiving the second DCI. The one or more third CORESETs are CORESETs configured to or is associated with the first BWP of the first cell. In FIG. 27, the wireless device may monitor BWP2 on Cell 1 in response to receiving the second DCI indicating the transition to the second power state for Cell 1 (e.g., a power saving release command) from Cell 0.

**[0239]** In existing technologies, a wireless device may receive at least one RRC message comprising configuration parameters of a first BWP and a second BWP for a cell. The wireless device is configured with either self-carrier scheduling or cross-carrier scheduling for the cell, wherein the self-carrier scheduling or the cross-carrier scheduling is used regardless of which BWP is activated. The wireless device may monitor a first DCI via one or more first CORESETs configured/associated on an active DL BWP of the cell if self-carrier scheduling is configured. The wireless device may monitor a second DCI via one or more second CORESETs configured/associated on an active DL BWP of a scheduling cell (e.g., a second cell, another cell) for the first cell, when the cross-carrier scheduling is configured for the first cell. As a self-carrier scheduling or a cross-carrier scheduling is configured per cell level, a base station may apply the self-carrier scheduling for a default BWP of the first cell when the self-carrier scheduling is configured to the first cell. Based on the configuration, a wireless device and the base station may need to maintain the cell in a non-dormant or a normal state, even when an active BWP of the cell is the default BWP and there is low active traffic scheduled for the cell. The

wireless device may consume unnecessary power to maintain one or more cells, configured with a self-carrier scheduling, with low activity in a normal state. There is a need for an enhanced downlink control monitoring mechanism for a cell with low traffic or no traffic.

5 **[0240]** FIG. 28 illustrates a configuration of a BWP in relationship to a cross-carrier or a self-carrier scheduling as implemented in legacy technologies. A wireless device may be configured with a cross-carrier scheduling for a cell by receiving one or more parameters of `CrossCarrierSchedulingConfig`, wherein the one or more parameters are applied to all configured bandwidth parts of the cell. In existing technologies, the wireless device may not apply self-carrier and cross-carrier differently per bandwidth part. To dynamically adapt the self-carrier or the cross-carrier scheduling based on an active BWP of the cell, the base station may need to reconfigure the self-carrier or the cross-carrier scheduling for the cell. This may increase network signaling and increase wireless device power consumption. There is a need to develop enhanced cross/self-scheduling mechanisms to reduce network signaling and increase wireless device power consumption. Example embodiments are directed to enhanced cross/self-scheduling mechanisms on a per BWP basis to improve network and wireless device performance.

10 **[0241]** In an embodiment, a wireless device may be configured with either a cross-carrier scheduling or a self-carrier scheduling for a bandwidth part configuration of a cell. A base station may configure a self-carrier scheduling for a first BWP of the cell. The base station may configure a cross-carrier scheduling for a second BWP of the cell. The wireless device may receive at least one message (e.g. RRC message) comprising configuration parameters indicating a self-carrier scheduling for a second BWP of a first cell and a cross carrier scheduling for a first BWP of the first cell. In an example, the wireless device may not monitor a control channel on the first cell in response to the wireless device switching to the first bandwidth part as an active BWP. In an example, the wireless device may monitor the control channel on the first cell in response to the wireless device switching to the second BWP as the active BWP. In an example, the wireless device may reduce power consumption by not monitoring the control channel on the first cell when the first BWP is the active BWP. As the wireless device may monitor a scheduling DCI for the first cell via a scheduling cell based on the cross-carrier scheduling configuration of the first BWP of the first cell, scheduling latency would be kept similar to a self-carrier scheduling case. Example embodiments may enhance power saving of the wireless device by stopping monitoring on the first cell with a low traffic on the first cell, while keeping scheduling latency for the first cell with the cross-carrier scheduling enabled. Example embodiments may increase flexibility and power saving by allowing dynamic switching of a scheduling cell for the first cell between the first cell and a second cell configured as the scheduling cell for the first cell when the cross-carrier scheduling is enabled. The base station may dynamically switch the scheduling cell based on a BWP switching.

15 **[0242]** FIG. 29 illustrates an example of related configurations to an embodiment. A wireless device may receive at least one message (e.g. RRC) comprising a cross-carrier scheduling parameters for a BWP. For example, BWP configuration may comprise `PDCCH-Config` indicating the cross-carrier scheduling or a self-scheduling configuration of the BWP. The wireless device may perform the cross-carrier scheduling in response to a bandwidth part switching to a first BWP of a cell configured with the cross-carrier scheduling. In an example, the cross-carrier scheduling may be configured for a default BWP of the cell. The wireless device may stop monitoring a control channel on the cell based on the wireless device being configured with cross-carrier scheduling for the default BWP of the cell, wherein an active BWP of the cell is the default BWP. In an example, a wireless device may transition to a dormant state of an SCell in response to the wireless device switching to a default BWP of the SCell and the default BWP being configured with a cross-carrier scheduling. The wireless device may perform measurements, such as RRM (radio resource management), RLM (radio link monitoring), L1-RSRP (physical layer reference signal receive power), and/or the like on the default BWP based on the default BWP being activated. The wireless device may skip monitoring any CORESET on the default BWP based on cross-carrier scheduling being configured on the default BWP, wherein the default BWP is an active BWP.

20 **[0243]** In an example, a wireless device may receive at least one message (e.g. RRC) comprising a set of parameters of a dormant state of a cell. The set of parameters may comprise a `bwp-Id` and a cross-carrier scheduling cell ID (e.g., SCell index, cell ID, cell index). Based on the wireless device transitioning to a dormant state of a cell, the wireless device may perform measurements of signals such as RRM, RLM, L1-RSRP, CSI, and/or the like on a BWP with the `bwp-Id` of the cell. The wireless device may stop monitoring a DCI on the dormant cell. The wireless device may start monitoring a DCI, comprising a resource assignment for the dormant cell, on a cell with the cross-carrier scheduling cell ID.

25 **[0244]** In an example, the wireless device may transition to a dormant state for a cell (e.g., activating/switching to /transitioning to a dormant SCell) in response to receiving a command indicating switching to a BWP with the `bwp-Id` (e.g., the `bwp-Id` configured for a dormant state) of the cell. In an example, the wireless device may transition to a dormant state for a cell (e.g., activating a dormant SCell) and switch to a BWP with the BWP-Id of the cell in response to receiving a command indicating transition to a power state (e.g., a dormant state) for the cell. The wireless device may receive the command via one or more DCIs, by one or more power state related timers (e.g., `dormantTimer`), by a BWP saving timer (e.g., `bwp-inactivityTimer`), by a DRX (e.g., starting `drx-onDurationTimer`), and/or the like.

30 **[0245]** FIG. 30 illustrates an example DRX operation with dormant cell (or a dormant state of a cell) in accordance with embodiments of the present disclosure. As shown in FIG. 30, at the beginning of a DRX active time signaled by a

drx-onDurationTimer, one or more SCells for a wireless device may be in a dormant state. The wireless device may switch the one or more SCells from the dormant state to an active state during the DRX active time. For example, the wireless device may switch the one or more SCells from the dormant state to the active state during the DRX active time based on receiving a DCI indicating an uplink or downlink grant (scheduling DCI). The wireless device may monitor for the DCI on the PCell. The wireless device may start drx-inactivityTimer in response to receiving the DCI for a downlink or uplink transmission.

**[0246]** The duration of time between starting the drx-onDurationTimer and starting the drx-inactivityTimer may be referred to as a first power state PS 1 (e.g., a dormant state or a power state). The duration of time between starting of the drx-inactivityTimer and starting of the DRX Off Duration may be referred to as a second power state PS2 (e.g., an active state or a normal state or a non-dormant state). During PS1, the wireless device may monitor for a DCI via one or more CORESETs of the PCell. During PS2, the wireless device may monitor for one or more DCIs via the one or more CORESETs of the PCell and one or more second CORESETs of the one or more SCells. The wireless device may transition the one or more SCells from the dormant state to the active state PS2. In an example, a wireless device may perform a reduced PDCCH monitoring on a PCell in PS1. For example, the wireless device may monitor for a DCI/PDCCH on a smaller number of PDCCH candidates, monitor a DCI/PDCCH with a larger periodicity, or monitor a DCI/PDCCH with a smaller number of search spaces, or monitor a DCI/PDCCH with a smaller number of CORESETs in response to the reduced PDCCH monitoring. The wireless device may switch/transition the PCell to PS1 for in response to starting of drx-onDurationTimer.

**[0247]** FIG. 31 illustrates an example of DRX operation enhancement with a sub-groups of cells and a dormant state for a cell. A wireless device may receive configuration parameters of one or more sub-groups within a cell group (e.g., a first cell group, a second cell group, or a PUCCH group). Example procedures described in the specification may apply within a sub-group of cells within a cell group. The wireless device may wake up a PCell or SPCell or transition the PCell or SPCell to a normal state that belongs to respective sub-group of cells, in response to *drx-onDurationTimer*. The wireless device may continue a sleep mode for one or more SCells or maintain a dormant state or a power saving state for the one or more SCells, wherein the one or more SCells belong to the same sub-group of cells as the PCell or SPCell in response to starting of the *drx-onDurationTimer*. The wireless device may switch an SCell to a dormant state for a sub-group of cells that does not include PCell or SPCell. A wireless device and/or a base station may determine an SCell to be placed into the dormant state (e.g., a dormant SCell) based on an SCell index of the SCell. For example, an SCell with the lowest cell index among the SCells in a sub-group of cells may be placed into the dormant state and referred to as a dormant SCell. In another example, the SCell with the highest cell index among the SCells in a sub-group of cells may be placed into the dormant state and referred to as a dormant SCell. Other example pre-determined rules may be implemented for determining a dormant SCell.

**[0248]** A wireless device may receive from a base station at least one message indicating a dormant SCell for a sub-group of cells. As shown in FIG. 31, the wireless device may switch the state of a PCell, in a first sub-group of cells (shown by a dashed box in FIG. 31) within a group of cells, to a normal state (e.g., an active or non-dormant state) in response to drx-onDurationTimer. In addition, in response to drxonDurationTimer, the wireless device may further keep SCell 1 and SCell N in asleep mode, but may switch SCell 2 (e.g., the selected SCell in the second sub-group) to a dormant state. In response to an event on the first sub-group of cells (e.g., reception of a scheduling DCI on the PCell), the wireless device may wake up SCells in the first sub-group of cells (e.g., SCell 1). In response to an event on the second sub-group of cells (e.g., reception of a scheduling DCI for SCell 2), the wireless device may wake up SCells in the second sub-group of cells. The wireless device may monitor a DCI comprising a resource assignment for SCell 2 on the PCell based on a cross-carrier configuration on a dormant state for SCell 2. The wireless device may monitor a DCI on active CORESETs for a cell in a normal power state.

**[0249]** In an example, a wireless device may wake-up one or more cell in a sub-group of cells in the first power state (e.g., start of drx-onDurationTimer). The wireless device may monitor a DCI at least on a PCell or a SPCell or the selected SCell as a leader of a sub-group.

**[0250]** In an example, a wireless device may receive configuration parameters of one or more sub-groups of cells within a cell group. The wireless device may wake-up one or more cells in a sub-group of cells in response to receiving a wake-up signal for the sub-group of cells. The wireless device may wake-up a PCell, SPCell, or a leader SCell of a sub-group of cells in response to receiving a go-to-sleep signal for the sub-group of cells or not receiving a wake-up signal for the sub-group of cells. The wireless device may switch a cell to a dormant state in response to receiving a go-to-sleep signal for the cell/sub-group of cells, where the cell belongs or not receiving a wake-up signal for the cell/sub-group where the cell belongs.

**[0251]** In an example, a wireless device switches to a dormant state for one or more SCells belonging to a sub-group, where the SCell is not a PCell, a SPCell or a SCell which is indicated as the leader SCell in the sub-group of cells, in response to drx-onDurationTimer. The wireless device switches to the normal state for a PCell, a SPCell, or a SCell which is indicated as the leader SCell in a sub-group, in response to drx-onDurationTimer. The wireless switches from a dormant state to a normal state of a cell upon receiving a scheduling DCI on a cell belonging to the same sub-group

of cells.

**[0252]** In an example, a wireless device may maintain at least one active DL BWP (and at least one UL BWP for a UL carrier if the UL carrier is present) of a cell regardless of a power state change of the cell. In an example, an event to change a power state may include changes between DRX On Duration and DRX Off Duration state based on DRX operation, changes between a first and second power state based on enhanced DRX operation, or switching from a power state to another power state based on a DCI command, a MAC-CE, or a timer.

**[0253]** In an example, a wireless device may keep the most recently activated DL BWP or UL BWP of a cell as the active DL BWP or UL BWP of the cell in response to a command indicating switching from a normal state to a dormant state of the cell (e.g., switching from PS2 to PS1). In an example, a wireless device may switch to a default DL BWP of a cell in response to a command indicating switching from a normal state to a dormant state of the cell.

**[0254]** In an example, a wireless device may not monitor a DCI comprising a resource assignment for a first cell, where the first cell is in a dormant state. In an embodiment, the wireless device is configured to monitor one or more search space sets or one or more CORESETs in a second cell, in response to a command indicating a power state from a normal to a dormant state of the first cell. In an example, a wireless device is configured with a cross-carrier scheduling cell for the first cell and the second cell is the scheduling cell.

**[0255]** FIG. 32 illustrates an example of an embodiment. A base station may configure one search space (e.g., SSi) for a BWP, and a BWP for a cell (e.g., SS1 for PCell, SS2 for SCell 1, SS3 for SCell 2, and SSk for SCell N) to a wireless device. The wireless device may be configured with a self-carrier scheduling on a cell when the cell is in a normal state. The wireless device may monitor a DCI on a cell, when the cell is in a normal state, comprising a resource assignment for the cell based on a self-carrier scheduling configuration. Based on an example shown in FIG. 31, the wireless device may receive RRC messages configuring two sub-groups of cells. The wireless device may wake-up only a PCell in a first power state (e.g., at the start of drx-onDurationTimer), may maintain a sleep state for SCell 1 and SCell N, and may switch SCell 2 to a dormant state. The wireless device may receive RRC messages to enable a cross-carrier scheduling for SCell 2 during a dormant state. The wireless device may receive a RRC message of a cross-carrier scheduling ID for SCell 2. For example, the wireless device may receive PCell as the cross-carrier scheduling cell for SCell 2. The wireless device may monitor a DCI comprising a resource assignment for SCell 2 on PCell while SCell 2 is in the dormant state (or in PS1). The wireless device may stop monitoring a DCI comprising a resource assignment for SCell 2 on PCell while SCell 2 is in a normal state (or in PS2). The wireless device receives a scheduling DCI for SCell 2 from PCell. In response to receiving the scheduling DCI, it may wake-up up the second sub-group. In waking-up the second sub-group, the wireless device may wake-up SCell N and may switch a power state of SCell 2 to a normal state (e.g., PS2). The wireless device may keep sleep mode during DRX Off duration. The wireless device may repeat the procedure in the next DRX cycle. The wireless device may not switch a power state of a cell without a command indicating the transition. FIG. 32 illustrates that SS1 on PCell may carry a first DCI and a second DCI when SCell 2 is in a dormant state (e.g., PS1), where the first DCI may comprise a resource assignment for PCell and the second DCI may comprise a resource assignment for SCell 2. For example, SS1 on PCell may not carry the second DCI in response to switching SCell 2 from PS1 to PS2. FIG. 32 illustrate a solid line indicating a DCI comprising a resource assignment for the indicated cell, and a dotted line indicating disabled the cross-carrier scheduling.

**[0256]** In an example, a wireless device may be configured with a plurality of BWPs of a first cell, wherein the first cell is configured as a cross-carrier scheduling cell for a second cell. The wireless device may switch from a first BWP of the plurality of BWPs of the first cell to a second BWP of the plurality of BWPs of the first cell in response to a BWP adaptation/switching command such as a DCI or a bwp-inactivityTimer, while the wireless device may stay on a first power state (e.g., a power saving state, a dormant state, PS1) of the second cell. The wireless device may monitor one or more DCIs for the second cell via one or more CORESETs of the first cell, wherein the second cell is in the first power state or in the dormant state. In monitoring the one or more DCIs for the second cell via the first cell, the wireless device may monitor one or more first CORESETs on the first BWP of the first cell based on an active BWP of the first cell is the first BWP. In monitoring the one or more DCIs for the second cell, the wireless device may monitor one or more second CORESETs of the second BWP of the first cell based on the active BWP of the first cell is switched/transitioned to the second BWP. The wireless device may monitor one or more search space CORESETs configured to the active BWP of the first cell, to receive a DCI comprising a resource assignment for the second cell during the dormant state of the second cell. The wireless device may determine the CORESET(s) and search space set(s), based on the active DL and/or UL BWP of the first cell, in response to a command switching the second cell to the dormant state on the scheduling cell or in response to a second command switching a BWP of the first cell.

**[0257]** For receiving a scheduling DCI on the second cell when the cross-carrier scheduling is enabled for the second cell (e.g., monitor PCell for a dormant SCell 2 in FIG. 32 in PS2 of SCell 2), a wireless device may monitor one or more search space of the first BWP of the first cell, where the one or more search space may carry a DCI comprising a resource assignment for the second cell. A wireless device may receive RRC messages comprising one or more parameters that indicate one or more search space sets monitored on the first cell (e.g., PCell in FIG. 32) for receiving a scheduling DCI for the second cell when a cross-carrier scheduling is enabled for the second cell.

**[0258]** FIG. 26A and FIG. 26B show an example embodiment of power saving enabling/disabling (or activating/deactivating) mechanism based on a DCI. A base station may transmit to a wireless device, one or more RRC messages comprising configuration parameters of a power saving (e.g., DRX state in FIG. 26A and 26B) operation (procedure, mode, or state). Upon receiving power saving activation (e.g., DRX state in FIG. 26A and 26B), a UE may assume that, at least for SCells, it may switch the cell/carrier to dormant state. In other words, different configurations may be configured per each serving cell depending on whether it is PCell (or SPCell) or SCell. The wireless device continues monitoring at least for PCell, SPCell or SCell of PUCCH SCell. The wireless device may receive a wake-up signal via a MAC-CE signaling or one or more of reference signals such as CSI-RS and/or tracking reference signals (TRS).

**[0259]** In an embodiment, a wireless device may switch a first cell from a first power state (e.g., a dormant state or PS1) to a second power state (e.g., a normal state or PS2) in response to receiving a command switching a bandwidth part on the first cell. In an example, the wireless device may transition to a power saving state (e.g., a dormant state) in response to receiving a DCI indicating a bandwidth part index that is not mapped to one of the configured BWPs for the first cell. In an example, the wireless device may be configured with three BWPs in the first cell, where the indices of the three BWPs may be 1, 2, and 3, respectively. When the wireless device receives a DCI indicating a BWP ID = 4 (e.g., BWP ID of non-configured BWP) for the first cell, the wireless may transition to a dormant state for the first cell. In this way, the wireless device may trigger a dormant state for a cell based on BWP adaptation mechanism using DCI signaling.

**[0260]** In an example, the size of a DCI field used to indicate a bandwidth part index may be increased to jointly indicate a bandwidth part index and/or a power state. In an example, states [0-3] may be used to indicate an index of a BWP of a cell, and states [4-7] may be used to indicate a power state of the cell. The wireless device may switch a power state of the cell if the BWP index is in the range of [4-7], while maintaining a currently active DL or UL BWP of the cell. The wireless device may switch the BWP of the cell if the BWP index is in the range of [0-3], while keeping the currently active power state of the cell.

**[0261]** In an example, a wireless device may skip monitoring a DCI in response to receiving a command indicating switching of a cell from a normal to a dormant state in one or more search space sets, in one or more CORESETs, with one or more RNTIs, and/or the like. For example, the wireless device may skip monitoring a DCI in one or more CORESETs among the configured CORESETs, or one or more SSs among the configured SSs in a dormant state of a cell. For example, the wireless device may skip monitoring a DCI with a set of RNTIs such as C-RNTI in a dormant state of a cell. In the example, the wireless may monitor a DCI with a set of RNTIs such as CS-RNTI, SI-RNTI, P-RNTI, SFI-RNTI, TCP-PUSCH-RNTI, TPC-PUCCH-RNTI, or INT-RNTI. In an example, a wireless device may be configured with a set of CORESETs, a set of search space, or a set of RNTIs monitored during a dormant state for a cell by the network via RRC messages and/or MAC CE and/or DCIs.

**[0262]** In an example, at least for an SCell, the wireless device may skip monitoring a DCI on one or more search space sets and CORESETs configured for an active DL BWP or UL BWP of a cell based on the cell being in the dormant state. For example, a wireless device may skip monitoring a DCI comprising a resource assignment for a scheduled cell on a set of search spaces or CORESETs on a scheduling cell in response to a configuration of cross-carrier scheduling, when the scheduled cell is in a dormant state.

**[0263]** In an example, for a cell in a dormant state, the wireless device may continue monitoring a DCI on beam-recovery CORESET(s)/search space set(s) and may skip monitoring of other CORESET(s)/search space set(s) associated with an active DL BWP or UL BWP of the cell. For example, a wireless device may continue beam recovery procedure in the dormant state of the cell. For example, when the wireless device is configured with a cross-carrier scheduling for a first cell, wherein a second cell is a scheduling cell for the first cell, the wireless device may receive one or more RRC messages indicating beam-recovery CORESET(s)/search space set(s) on the second cell. The wireless device may monitor the beam-recovery CORESET(s)/search space set(s) on the second cell and may skip monitoring other CORESET(s)/search space set(s) on the second cell for a DCI comprising a resource assignment for the first cell.

**[0264]** In an example, the wireless device may continue monitoring one or more CORESETs/search space sets of an active BWP in a dormant cell (e.g., a cell in a dormant state). For example, the one or more CORESETs/search space sets may carry a DCI comprising a resource assignment for broadcast or a group-common message such as SFI, TPC, puncturing indication, and/or the like. For example, the one or more CORESETs/search space sets may carry a DCI that is CRC scrambled with a RNTI such as SI-RNTI, P-RNTI, SFI-RNTI, and/or the like. For example, the one or more CORESETs/search space sets may carry a DCI that is CRC scrambled with a RNTI such as SI-RNTI, P-RNTI, SFI-RNTI, INT-RNTI, TPC-PUCCH-RNTI, TPC-PUSCH-RNTI, TPC-SRS-RNTI, and/or the like.

**[0265]** A wireless device may continue/perform measurements and reporting for a cell, such as CSI measurement/feedback, L1-RSRP measurement/feedback, new candidate beam RS measurement/beam-failure recovery, radio link monitoring/failure recovery, and/or the like when the cell is in a dormant state. The wireless device may receive one or more RRC messages comprising one or more RS parameters used for the measurements and reporting for the cell in a dormant state. The wireless device may determine the one or more RS parameters based on the one or more RRC messages if provided. The wireless device may determine the one or more RS parameters based on one or more second

RS parameters associated with an active DL or UL BWP of the cell, or associated with the cell, if it is not provided by the one or more RRC messages. The wireless device may determine the one or more RS parameters based on the one or more second RS parameters and a power state (e.g., a dormant state or a normal state) of the cell. For example, a wireless device may perform a limited number of measurements and reporting, such as RRM or RLM. A wireless device may keep active DL or UL BWP of the cell in response to switching to a dormant state of the cell. The wireless device may use one or more RS parameters of currently/previously active DL or UL BWP of the cell in response to switching to the dormant state of the cell. The wireless device may receive one or more RRC messages comprising RS parameters for measurement/reporting.

**[0266]** In an example, a wireless device may switch to a dormant state of a first cell in response to receiving a go-to-sleep or not receiving a wake-up signal, and may switch to a normal state of a second cell in response to receiving a wake-up or not receiving a go-to-signal. For example, the wireless device may not monitor a first DCI comprising a resource assignment for a downlink data in the first cell. The wireless device may monitor a second DCI comprising a resource assignment for broadcast or a group common DCI such as SFI, TPC, and/or the like. The wireless device may continue a dormant state of the first cell until the next wake-up duration or wake-up signal occasion. In FIG. 33, the wireless device may receive a wake-up signal indicating waking PCell and SCell 1, and not waking up SCell 2 and SCellN. In response to the command, it may start monitoring on SS1 and SS2 which are configured to PCell and SCell 1, and it may skip monitoring on SS3 and SSk which are configured to SCell 2 and SCellN. In the example, a wireless device is not able to receive a scheduling DCI on SCell 2 and SCellN until the next round of wake-up signal transmission. In an example, a wake-up signal may jointly operate with DRX operation, e.g., wake-up signal indicates DRX OnDuration active and a go-to-sleep signal may indicate DRX Off (e.g., skip DRX active time in the current DRX cycle). In an example, a wake-up signal may operate with or without a DRX configuration. Regardless of DRX configuration, a wake-up signal may indicate a wireless device to wake-up the indicated cell. FIG. 35 illustrates an example on UE monitoring a DCI on different set of search spaces.

**[0267]** In an example, a wireless device may receive a wake-up signal indicating PCell wake-up. The wireless device may wake-up in response to the wake-up signal, and may keep SCell 1 in a sleep mode. In the example, the wireless device is configured with two sub-groups, wherein the first group consists of PCell and SCell 1 and the second group consists of SCell 2 and SCellN (based on FIG. 31). The wireless device may switch SCell 2, a leading cell of the second sub-group, to a dormant state, and may start monitoring a scheduling DCI on PCell for SCell 2 (as configured for scheduling cell for SCell 2) during the dormant state of SCell 2. When the wireless device receives a scheduling DCI on SCell 2, it may wake up all other cells in the second sub-group, and may start monitoring a DCI on search spaces on the cells. The wireless device may switch to self-carrier scheduling once it switches from a dormant state to a normal state on SCell 2. In response to switching to the normal state of SCell 2, the wireless may stop monitoring a DCI based on a cross-carrier scheduling from PCell on SCell 2. The wireless device may stop the cross-carrier scheduling when SCell 2 switches from the dormant state to the normal state.

**[0268]** In an example, a wireless device may receive a first DCI indicating a wake-up or go-to-sleep state or transitioning of a power state (e.g., a dormant state, a normal state) of each cell belonging to a first sub-group or a first cell group. The wireless device may receive a second DCI indicating a wake-up or go-to-sleep state or transitioning of a power state (e.g., the dormant state, the normal state) of each cell belonging to a second sub-group or a second cell group. The first DCI may be transmitted jointly or independently from the second DCI. For example, the first DCI may be a same to the second DCI. The first DCI may be a separate DCI from the second DCI. The wireless device may change the state of each cell based on the signal per each sub-group or per cell-group. FIG. 36 illustrates an example. The wireless may receive a first DCI activating the first sub-group. The wireless device may start monitoring on PCell in response to the first DCI (e.g., PS activation DCI) for the first sub-group. The wireless device may receive a second DCI indicating PS activation on the second sub-group. The wireless device may switch the cells in the second-group to a dormant state (e.g., power state or PS1) in response to the second DCI (e.g., PS activation DCI). The wireless device may switch all the cells of the second sub-group to a dormant state based on the second sub-group having no PCell, SPCell or PUCCH SCell. The wireless device may deactivate a power state or switch from the dormant state to the normal state in response to receiving a third DCI deactivating power state or changing a power state to the normal state.

**[0269]** A power saving activation/deactivation DCIs may be jointly transmitted with a scheduling DCI, wherein the scheduling DCI may comprise a resource assignment for a cell and one or more indications to transition one or more sub-groups between the dormant state and the normal state. In the example, the wireless device may switch/transition PCell or a primary cell of a cell group to the dormant state regardless of indications via the power saving activation/deactivation DCI. For example, the primary cell may be a primary cell of a first cell group or a master cell group. For example, the primary cell may be a primary cell of a second cell group or a secondary cell group. For example, the primary cell may be a PUCCH cell of a PUCCH group. In response to receiving the power saving activation/deactivation DCI for a sub-group, the wireless device may transition each cell of the sub-group to the dormant state or to the non-dormant state. For example, in FIG. 36, the wireless device transitions a first secondary cell (SCell 1) to a dormant state in response to receiving the first DCI indicating transition to the dormant state of the first sub-group. The wireless device

may maintain the PCell in the non-dormant/normal state, and transition the SCell 1 to the dormant state.

**[0270]** The wireless device receives the second DCI indicating transition of the second sub-group to the dormant state. The wireless device transitions SCell 2, ..., SCell N to the dormant state. The wireless device maintains previous power state for other sub-groups. For example, the wireless device maintains the dormant state for the first sub-group in response to the second DCI. The wireless device receives the third DCI indicating transition of the first sub-group to the normal state. The wireless device transitions SCell 1 and PCell to the normal state. The wireless device maintains the dormant state for one or more cells of the second sub-group. The wireless device receives a fourth DCI indicating transition of the second sub-group to the normal state. The wireless device transitions SCell 2, ..., SCell N to the normal state while maintaining the power state for cells of the first sub-group.

**[0271]** Grouping cells into a few sub-groups may reduce signaling overhead. Moreover, a wireless device may assume that all cells in a sub-group may transition simultaneously. Based on the configuration, the wireless device may assign/allocate its radio resources more effectively. For example, when a first cell and a second cell belong to a same sub-group, the wireless device may assign shared RF resources between the first cell and the second cell. When the same sub-group transitions to the dormant state, the wireless device may reduce or turn off the shared RF resources for both cells. Embodiments allow enhanced power saving with a low signaling overhead. Embodiments allow a scalable signaling design for transitioning a power state between the dormant state and the normal state with increased frequencies of power state transitions and a number of serving cells.

**[0272]** In an example, a wireless device may be configured with a special BWP triggering a dormant state for a cell. The wireless device may switch to the dormant state for a first cell in response to receiving a command indicating switching to the special BWP of the first cell. In an example, a wireless device may receive RRC configurations to enable a cross-carrier scheduling in response to switching to the special BWP. The wireless device may be configured with a cross-carrier scheduling for the special BWP while the wireless device is configured with a self-carrier scheduling for another BWP(s) of the first cell. FIG. 37 shows an example. A wireless device is configured with BWP1 and a default BWP (e.g., BWP0 and a default BWP indicates BWPO) for Cell 0, and BWP2, a default BWP0 and a special BWP1 which is used for the dormant state for SCell 1. The wireless device may be configured with a self-carrier scheduling on BWP2 and BWP0 of SCell 1. The wireless device may be configured with a cross-carrier scheduling on BWP1 (e.g., dormant state). The wireless device may activate SCell 1 with BWP2 based on BWP2 being configured as the first active BWP for SCell 1. In response to receiving a DCI on SS3 indicating a BWP switching to BWP1 on SCell 1, the wireless device may transition SCell 2 to the dormant state. In response to transitioning to a dormant state, the wireless device may activate a cross-carrier scheduling for SCell 1 on Cell 0, wherein the wireless device monitors SS0 (search space of the current active BWP of Cell 0) for a DCI comprising a resource assignment for SCell 1 and a DCI comprising a resource assignment for Cell 0. In response to receiving a BWP switching on SCell 1 from a dormant BWP (e.g., BWP1) to BWP2, the wireless device may stop the cross-carrier scheduling from Cell 0 and starts self-carrier scheduling monitoring on SS2.

**[0273]** In an example, the wireless device may switch to the special BWP in response to a timer or a command via a DCI instead of based on a DCI comprising a resource assignment and bandwidth part index. The wireless device may be indicated with a bandwidth part index indicating the BWP used in dormant state by a DCI.

**[0274]** In an embodiment, a wireless device may indicate to a base station/network whether the wireless device may support additional cross-carrier scheduling in a dormant state of a cell. The network may configure a cross-carrier scheduling for a dormant cell in response to the indication that the wireless device may support.

**[0275]** In an embodiment, a wireless device may perform a cross-carrier scheduling for a dormant cell without incurring additional blind decoding or candidates. In an example, a same DCI format and size is used for a first DCI and a second DCI on the same search space of a scheduling cell. The wireless device may monitor the first DCI comprising a resource assignment for a first cell. The wireless device may monitor the second DCI comprising a resource assignment for a second cell. The second cell is in a dormant state and the first cell may schedule a DCI for the second cell while the second cell is in a power saving state. The wireless device may determine each DCI field size of the first and second DCI based on the current active DL or UL BWP of the first cell. The wireless device may interpret or decode each DCI field of the first DCI based on the active DL or UL BWP of the first cell (e.g., a scheduling cell) or based on the new active DL or UL BWP of the first cell that the second DCI may include a bandwidth part index and may indicate a switching of BWP on the first cell. The wireless device may interpret or decode each DCI field of the second DCI based on the active DL or UL BWP of the second cell (e.g., a dormant cell) or based on the new active DL or UL BWP of the second cell that the second DCI may include a bandwidth part index and may indicate a switching of BWP on the second cell. The DCI field of the first DCI may be truncated or padded with zero bits to align a size of a DCI field to a required size of the DCI field. The wireless device may determine the required size of a DCI field, for the second DCI, based on the active DL or UL BWP of the second cell (e.g., a dormant cell) or based on the new active DL or UL BWP of the first cell that the second DCI may include a bandwidth part index and may indicate a switching of BWP on the second cell.

**[0276]** The wireless device may use a first RNTI on the first DCI, and a second RNTI on the second DCI. In an example, the wireless device may use the first RNTI on a DCI comprising a resource assignment on a cell in a cell group, where

the cell is not in dormant state. The wireless device may use C-RNTI as the first RNTI. The wireless device may derive the second RNTI based on the first RNTI. In an example, the second RNTI is based on the first RNTI + offset or the first RNTI + SCell index of a dormant cell or the first RNTI + an indicated offset where the offset is indicated by the network via a RRC message. The wireless device may receive RRC messages indicating one or more values for the second RNTI.

5 **[0277]** FIG. 38 illustrates an example of a DCI size of the second DCI. The wireless device may determine each DCI field size for the second DCI based on the scheduling cell configuration (e.g., the first cell). For example, CIF is not used for the cross-carrier scheduling in response to a cross-carrier scheduling activated for a cell when the cell becomes a dormant state. For other DCI field sizes, the sizes are determined based on the scheduling cell's active DL or UL BWP. The size of DCI field is determined based on active UL BWP of the scheduling cell if a DCI comprises uplink resource assignment. The size of DCI field is determined based on an active DL BWP of the scheduling cell if a DCI comprises downlink resource assignment. In an example, the wireless device interprets each DCI field based on the configurations of the active or indicated DL or UL BWP of the scheduled cell (e.g., dormant cell) in response to a DCI scheduled by cross-carrier. The wireless device applies padding or truncation of a DCI field in interpreting the field according to the scheduled cell.

15 **[0278]** In an example, a wireless device may determine the size of the second DCI based on the size of the first DCI. The wireless device may determine the size of the first DCI based on current active DL and/or UL BWP of the first cell (e.g., scheduling cell). The wireless device may use a new DCI format for the second DCI compared to the DCI format used in the first DCI while keeping the same size between the first and second DCI. For example, the new DCI format may comprise CIF (e.g., cross-carrier indication field), one or more DCI fields from a fallback DCI (e.g., DCI format 0\_0 for uplink scheduling and 1\_0 for downlink scheduling), and zero or one or more bits reserved. In case, sizes that are sum of CIF bits and one or more DCI fields from the fallback DCI may be larger than the size of the first DCI, the wireless device may not perform a cross-carrier scheduling of the second cell while the second cell is in the dormant state.

20 **[0279]** In response to the second cell being configured with only one bandwidth part, the second DCI sets the bandwidth part index field (if present) to '00', '0' or a constant, depending on the bit size. In response to the first DCI not having a bandwidth part index field, a 'pre-fixed' BWP of the second cell is indicated in case the wireless is configured with more than one BWPs in the second cell. For example, the pre-fixed BWP is the lowest indexed BWP among BWPs configured to the second cell. For example, the pre-fixed BWP is the highest indexed BWP among BWPs configured to the second cell. For example, the pre-fixed BWP is the current active DL or UL BWP of the second cell. For example, the pre-fixed BWP is a default BWP of the second cell. For example, the pre-fixed BWP is a previously active DL or UL BWP except for the special BWP of the second cell when the special BWP is used to switch to the dormant state.

25 **[0280]** In interpreting DCI field sizes, for example, frequency domain resource allocation is determined based on bandwidth, RBG size and resource allocation type configuration of active BWP of scheduling cell, and for scheduled cell, the required field size may be smaller or larger depending on the configuration in the scheduled cell's BWP. In case, scheduled cell may require larger size, zero padding on MSBs is assumed. In case scheduled cell may require smaller size, truncation on MSBs is assumed.

30 **[0281]** In an example, a wireless device may monitor one or more DCI formats for the second DCI on the first cell when cross-carrier scheduling is enabled. For example, the wireless device may monitor a non-fallback DCI (such as DCI format 1\_1 or DCI format 0\_1). For example, the wireless may monitor a non-fallback DCI and fallback DCI formats (e.g., DCI format 1\_1, 1\_0, 0\_0, 0\_1).

35 **[0282]** In an example, a wireless device may consider additional blind decoding or candidates from cross-carrier scheduling to support a dormant cell in the UE capability regardless of whether the device is performing cross-carrier scheduling or not. In the example, the wireless device may take the additional budget into account to support a cross-carrier scheduling regardless whether the cross-carrier scheduling is enabled or not.

40 **[0283]** In an example, a wireless device may be configured with one or more semi-persistent search space sets (SP-SSs) for a first cell and the associated parameters such as one or more DCI formats and RNTIs monitored on a search space set. A wireless device may receive RRC messages comprising one or more parameters indicating periodicity, offset, duration for a SP-SS, cross-carrier or self-carrier (or a scheduling cell ID). The wireless device may activate the one or more SP-SSs on the scheduling cell in response to transition of the first cell to a dormant state. For example, the periodicity and the duration of a SP-SS may be aligned with the DRX cycle periodicity and DRX OnDuration.

45 **[0284]** In an example, a wireless device may change one or more search space sets or CORESETs for monitoring a DCI on a cell via a dynamic signaling. In an example, for each cell, the wireless device may receive a bitmap comprising all the CORESETs configured over the all active cells. In response to an indication that a CORESET in another cell is activated, the wireless device may start a cross-carrier scheduling on the indicated cell.

50 **[0285]** In an example, a base station may configure a wireless device to associate between a BWP to a DRX state for a cell. For example, the wireless may receive RRC messages associating a first BWP to a first power state on DRX OnDuration (e.g. a first DRX state) and a second BWP to a second power state on DRX OnDuration (e.g., a second DRX state). FIG. 39 illustrates an example. In the example, a wireless device is configured with BWP1 for PCell and BWP2 for SCell during the second DRX state to be activated. The wireless device, on the first DRX state, may activate

BWP0 of PCell (assuming default BWP is BWPO) and a dormant state of BWP0 for SCell. The wireless device may switch a BWP in each cell in response to a switching of DRX state to the second DRX state, to BWP1 and BWP2 for PCell and SCell respectively. In response to the bwp-inactivityTimer expiry on SCell, the wireless device switches SCell BWP to BWP0. In an example, a same procedure may be applied to one or more power states triggered by a DCI or

5  
[0286] FIG. 40 illustrates an example of the above mechanism in case of one or more sub-group configuration. For each cell, a first and a second BWP may be associated with a first and second DRX state respectively. The wireless device switches DRX state per each sub-group. In an example, the wireless device switches from the first DRX state to the second DRX state for SCell 2 in response to receiving a scheduling DCI on SCell 2 instead of responding to a scheduling DCI on PCell.

10  
[0287] In an example, a wireless may monitor RNTIs corresponding to a unicast scheduling such as C-RNTI, SPS-RNTI, MCS-new-RNTI, and/or the like on the set of search spaces configured/indicated to monitor on another cell when the cross-carrier scheduling is enabled in response to a power state change from a normal to a dormant state of a cell.

15  
[0288] In an example, a wireless may monitor one or more first search spaces of the current active DL or UL BWP of the another scheduling cell for a DCI comprising a resource assignment on the cell which is in dormant state, wherein the one or more first search spaces may carry a DCI comprising a resource assignment for unicast downlink or uplink transmission.

20  
[0289] FIG. 41 illustrates a diagram of the embodiment based on a power state change via a DCI mechanism. For example, a wireless device may receive one or more RRC messages comprising parameters of one or more first CORESETs of a first cell. The configuration parameters may further comprise a second cell ID. The wireless device may receive a DCI comprising a resource assignment for the first cell, wherein the DCI is transmitted via one or more first CORESETs of the first cell. The wireless device may receive a DCI indicating transition or activation of a dormant state or a power saving state via a DCI, a MAC CE, or DRX state change. The wireless device may determine one or more second CORESETs of the second cell, based on an active BWP of the second cell, in response to transition to the dormant state of the first cell. The wireless device may monitor a DCI comprising a resource assignment for the first cell via the one or more second CORESETs of the second cell. In response to the DCI indicating transition the first cell to a normal state, the wireless device may transition to the normal state for the first cell. The wireless device may receive data via the first cell in response to the switching to the normal state. Otherwise, the wireless device may continue monitoring the one or more second CORESETs of the second cell for the first cell.

25  
30  
[0290] FIG. 42 illustrates a diagram of the embodiment based on a power state change via a DRX mechanism. In an example, a wireless device may receive one or more RRC messages. The one or more RRC messages may comprise configuration parameters of a first BWP for a secondary cell (SCell). The wireless device may start drx-onDurationTimer. The wireless device may start a first DRX state and may switch to the first BWP of the SCell. In response to switching to the first BWP of the SCell, the wireless device may stop monitoring for one or more DCIs on the first BWP. The wireless device may receive a first DCI based on a cross-carrier scheduling, wherein the first DCI may be transmitted via a second cell. The wireless device may determine whether the first DCI is a unicast scheduling DCI. In response to the first DCI being the unicast scheduling DCI, the wireless device may start drx-inactivityTimer. The wireless device may switch to a second BWP, wherein the second BWP may be indicated in the first DCI. The wireless device may monitor a second DCI on the second BWP of the SCell.

35  
40  
45  
50  
55  
[0291] A wireless device may receive one or more radio resource control (RRC) messages comprising: a first control resource set on a first cell and/or a second control resource set on a second cell for receiving a downlink control information (DCI) comprising a resource assignment on the first cell. Example configuration parameters include a bandwidth part configuration for the first cell, a PDCCH-config comprising a set of CORESETs and set of search spaces, a PDSCH-config comprising a list of resource allocations, and/or the like. For example, a PDCCH-config of a BWP of the first cell may include a cross-carrier scheduling cell ID. For example, a cross-carrier scheduling cell ID may be configured to the first cell regardless of a bandwidth part, wherein the cross-carrier scheduling cell will schedule a DCI for the first cell in response to a command switching the first cell from a normal state to a dormant state (or from a first power state to a second power state). The wireless device may monitor the first control resource set on the first cell in response to the first cell being in a first power state. The wireless device may receive a command indicating switching the first cell from the first power state to a second power state. In response to the command, the wireless device may monitor the second control resource set on the second cell for receiving a DCI comprising a resource assignment on the first cell. In response to the command, may stop monitoring the first control resource set on the first cell. The wireless device may receive a DCI on the second cell during the monitoring the second control resource set, wherein the DCI indicates a resource assignment for the first cell. In response to the DCI, the wireless monitors the first control resource set on the first cell. The wireless device may continue monitoring on the second control resource set for a DCI scheduling for the second cell and stop monitoring the second control resource set on the second cell for a receiving a scheduling DCI for the first cell.

[0292] In an example, a wireless device determines the first control resource sets on the first cell based on the current active DL or UL BWP of the first cell, and self-carrier and cross-carrier scheduling configuration. In an example, if cross-

carrier scheduling is configured for the first power state, a first cross-carrier scheduling cell used in the first power state and the second cell used in the second power state may be different.

**[0293]** In an example, a wireless device determines the second control resource sets on the second cell based on the current active DL or UL BWP of the second cell. In an example, the wireless device selects all of the one or more configured CORESETs in the current active DL or UL BWP of the second cell as the second control resource set. In the example, the wireless device receives one or more RRC messages indicating a cross-carrier scheduling cell ID, wherein the cell ID is to indicate the second cell. In an example, the network may transmit RRC message(s) to indicate one or more CORESETs from the one or more configured CORESETs in the current active DL or UL BWP of the second cell as the second control resource set.

**[0294]** In an example, the wireless device may select one or more third CORESETs/search space sets from the one or more configured CORESETs in the current active DL or UL BWP of the second cell as the second control resource set, wherein the one or more third CORESETs/search space may transmit a DCI comprising a resource assignment of unicast downlink or uplink data.

**[0295]** In an example, the wireless device may monitor a DCI on the second resource set of the second cell, wherein the DCI may comprise a resource assignment for a unicast downlink or uplink data for the first cell. The wireless device may skip monitoring on another DCI on the second resource set of the second cell, wherein the DCI may comprise a resource assignment for broadcast downlink or a list of entries for a group-common DCI such as SFI, puncturing indication, TPC commands.

**[0296]** In an example, the wireless device may monitor RNTI for a unicast data scheduling, and may not monitor other RNTIs on the second resource set.

**[0297]** In an example, the wireless device may determine transmission parameters for the scheduled downlink or uplink data based on one or more DCI fields of a second DCI on the first cell and an active downlink or uplink BWP of the first cell, wherein it monitors the second DCI on the first control resource set.

**[0298]** In an example, the wireless device may determine a DCI field size of a third DCI based on one or more DCI formats and fields on the second cell and an active downlink or uplink BWP of the second cell, wherein the wireless device monitors the third DCI on the second control resource set. In the example, the wireless device may interpret a DCI field of the third DCI based on an active downlink or uplink BWP or an indicated downlink or uplink BWP by the third DCI.

**[0299]** The wireless device may use a first RNTI on the first CORESETs on the first cell in detecting a DCI comprising a resource assignment of the first cell.

**[0300]** In an example, the wireless device may use a second RNTI on the second CORESETs on the second cell in detecting a DCI comprising a resource assignment for the first cell.

**[0301]** In an example, the wireless device may receive the third DCI indicating a bandwidth part of the first cell and a resource assignment of the first cell on the second cell. In an example, a BWP ID of the first cell may be indicated by the network by one or more RRC messages. In an example, the wireless device may switch to the indicated BWP ID of the second cell in response to the third DCI if the third DCI contains a BWP ID, or in response to the one or more RRC messages if the third DCI may not contain a BWP ID.

**[0302]** In an example, a wireless may receive one or more second RRC messages comprising: one or more third CORESETs for a first BWP part of the first cell and one or more fourth CORESETs for a second BWP of the first cell. For example, the wireless device may receive one or more RRC messages comprising a cross-carrier scheduling ID associated with the one or more fourth CORESETs. In the example, the wireless device may monitor the one or more third CORESETs on the first cell. The wireless device may monitor the one or more fourth CORESETs on a third cell (on the cross-carrier scheduling ID indicated cell), wherein a DCI on the fourth CORESETs may comprise a resource assignment on the second BWP of the first cell.

**[0303]** In an example, the wireless device applies same embodiments, for the second CORESET and associated DCIs on the second cell for the first cell, to the fourth CORESETs and associated DCIs.

**[0304]** In an example, the wireless device and base station may use DRX mechanism, and/or MAC CEs for power saving activation and/or deactivation instead of or in addition to DCI based power saving activation and/or deactivation mechanisms. For example, the wireless device may receive a MAC CE on the PCell or another cell to activate a dormant state or a power saving state. For example, the wireless device may start drx-onDurationTimer on a cell group or on the PCell or another cell to activate a dormant state of SCells or other cells or power saving state of SCells or other cells.

**[0305]** In an example, a wireless device determines a first power state in response to drx-onDurationTimer start, and a second power state in response to drx-inactivityTimer start.

**[0306]** In an example, a wireless device receives one or more RRC messages indicating a first BWP and a second BWP of a cell for the first and second power state of DRX state. The wireless device switches to the first BWP in response to drx-onDurationTimer start and switches to the second BWP in response to drx-inactivityTimer start.

**[0307]** A wireless device may receive one or more radio resource control (RRC) messages comprising: a first control resource set on a first cell and/or a second control resource set on a second cell for receiving a downlink control information

(DCI) comprising a resource assignment on the first cell. The wireless device may monitor the first control resource set on the first cell in response to the first cell being in a first power state. The wireless device may receive a command indicating switching the first cell from the first power state to a second power state. In response to the command, the wireless device may monitor the second control resource set on the second cell for receiving a DCI comprising a resource assignment on the first cell. In response to the command, may stop monitoring the first control resource set on the first cell. In monitoring the second control resource set on the second cell, the wireless device may monitor a first DCI with a first RNTI for receiving a DCI comprising a resource assignment for the second cell and the wireless device may monitor a second DCI with a second RNTI for receiving a DCI comprising a resource assignment for the first cell. The wireless device may receive a DCI on the second cell during the monitoring the second control resource set, wherein the DCI indicates a resource assignment for the first cell. In response to the DCI, the wireless monitors the first control resource set on the first cell. The wireless device may continue monitoring on the second control resource set for a DCI scheduling for the second cell and stop monitoring the second control resource set on the second cell for a receiving a scheduling DCI for the first cell.

**[0308]** A wireless device may receive one or more radio resource control (RRC) messages for a first cell. The one or more RRC messages may comprise a first scheduling cell and a first bandwidth part. The first scheduling cell is the first cell. The one or more RRC messages may comprise a second scheduling cell and a second bandwidth part. The first scheduling cell is a second cell. In response to receiving a command indicating a bandwidth part switching to the first bandwidth part of the first cell, the wireless device may switch to the first bandwidth part and start monitoring a DCI on the first cell. The DCI may comprise a resource assignment for the first bandwidth part of the first cell. In response to receiving a command indicating a bandwidth part switching to the second bandwidth part, the wireless device may switch to the second bandwidth part of the first cell and start monitoring a second DCI on the second cell. The second DCI may comprise a resource assignment for the second bandwidth part of the first cell.

**[0309]** A wireless device may receive one or more radio resource control (RRC) messages comprising: a first control resource set on a first cell and/or a second control resource set on a second cell for receiving a downlink control information (DCI) comprising a resource assignment on the first cell. The wireless device may monitor the first control resource set on the first cell in response to the first cell being in a first power state. The wireless device may receive a command indicating switching the first cell from the first power state to a second power state. In response to the command, the wireless device may determine the second control resource set based on a current active DL BWP of the second cell, one or more search space configurations of the current active DL BWP of the second cell, and/or one or more RNTIs used for a DCI comprising a resource assignment for a unicast DL or UL data for the first cell. In response to the command and based on the second resource set determination, the wireless device may monitor the second control resource set on the second cell for receiving a DCI comprising a resource assignment on the first cell. In response to the command, may stop monitoring the first control resource set on the first cell. The wireless device may receive a DCI on the second cell during the monitoring the second control resource set, wherein the DCI indicates a resource assignment for the first cell. In response to the DCI, the wireless monitors the first control resource set on the first cell. The wireless device may continue monitoring on the second control resource set for a DCI scheduling for the second cell and stop monitoring the second control resource set on the second cell for a receiving a scheduling DCI for the first cell.

**[0310]** FIG. 43 is a flow diagram of a method performed by a wireless device as per an aspect of an example embodiment of the present disclosure. At 4310, the wireless device may receive one or more radio resource control (RRC) messages comprising configuration parameters indicating a first secondary cell (SCell) group comprising one or more first cells and a second SCell group comprising a plurality of second cells. At 4320, the wireless device may activate, in a non-dormant state, the one or more first cells and the plurality of second cells. At 4330, in response to receiving a downlink control information indicating transitioning the first SCell group to a dormant state, the wireless device may transition the one or more first cells to the dormant state and maintain the plurality of second cells in the non-dormant state.

**[0311]** In an example, transitioning a cell to the dormant state may comprise transitioning from a non-dormant BWP of the cell to a dormant BWP of the cell as an active BWP.

**[0312]** In an example, the non-dormant BWP of the cell may be different from the dormant BWP of the cell.

**[0313]** In an example, an active BWP of a cell in the non-dormant state is a non-dormant BWP.

**[0314]** In an example, the one or more first cells and the plurality of second cells are activated serving cells of the wireless device.

**[0315]** In an example, the wireless device may stop monitoring for a DCI on a first cell in the dormant state, wherein the first cell is one of the one or more first cells or one of the plurality of second cells.

**[0316]** In an example, the wireless device may perform channel state information (CSI) measurement for CSI feedback of the first cell in the dormant state. The wireless device may perform a L1 reference signal receive power (RSRP) measurement for beam management of the first cell in the dormant state.

**[0317]** In an example, the wireless device may maintain a primary cell, a special primary cell, or a PUCCH cell in the non-dormant state regardless of an indication to transition a power state.

**[0318]** In an example, a cell, of the one or more first cells or the plurality of second cells, in the dormant state, may

be activated in the dormant state, wherein a first active BWP configured for the cell is a dormant BWP of the cell.

**[0319]** FIG. 45 is a flow diagram of a method performed by base station as per an aspect of an example embodiment of the present disclosure. At 4410, a base station may transmit one or more radio resource control (RRC) messages comprising configuration parameters indicating: a first secondary cell (SCell) group comprising one or more first cells and a second SCell group comprising a plurality of second cells. At 4420, the base station may transmit one or more commands activating, in a non-dormant state, the one or more first cells and the plurality of second cells. At 4430, the base station may determine transitioning the first SCell group to a dormant state and maintaining the plurality of second cells in the non-dormant state. At 4440, the base station may transmit a downlink control information indicating the transitioning of the first SCell group to the dormant state.

**[0320]** In an example, transitioning a cell to the dormant state may comprise indicating transitioning from a non-dormant BWP of the cell to a dormant BWP of the cell as an active BWP.

**[0321]** In an example, the non-dormant BWP of the cell may be different from the dormant BWP of the cell.

**[0322]** In an example, the base station may configure the one or more first cells and the plurality of second cells as activated serving cells to a wireless device.

**[0323]** In an example, the base station may stop transmitting a DCI on a first cell in the dormant state, wherein the first cell is one of the one or more first cells or one of the plurality of second cells.

**[0324]** In an example, the base station may maintain a primary cell, a special primary cell, or a PUCCH cell in the non-dormant state regardless of an indication to transition a power state.

**[0325]** In an example, the base station may configure a first active BWP of a second cell as a dormant BWP of the second cell, wherein the base station determines to activate the second cell in the dormant state in response to an activation command.

**[0326]** In an example, a wireless device may receive one or more radio resource control (RRC) messages comprising configuration parameters indicating a first secondary cell (SCell) group comprising one or more first cells and a second SCell group comprising a plurality of second cells. The wireless device may activate the one or more first cells, wherein each cell of the one or more first cells in respective first non-dormant bandwidth part (BWP). The wireless device may activate the plurality of second cells, wherein each cell of the plurality of second cells is in respective second non-dormant BWP. The wireless device may receive a downlink control information (DCI) indicating transitioning the first SCell group to a dormant state. The wireless device, in response to the DCI, may transition from the respective first non-dormant BWP to a respective dormant BWP for each of the one or more first cells and may maintain the second respective non-dormant BWP for each of the plurality of second cells.

**[0327]** In an example, the one or more first cells are activated serving cells of the wireless device. The plurality of first cells are activated serving cells of the wireless device.

**[0328]** In an example, the one or more first cells are in a dormant state or a first power state, wherein the each cell of the one or more first cells is in the respective dormant BWP.

**[0329]** In an example, the one or more first cells are in a non-dormant state or a second power state, wherein the each cell of the one or more first cells is in the respective first non-dormant BWP.

**[0330]** In an example, the plurality of second cells are in the dormant state or the first power state, wherein each cell of the plurality of second cells is in a second respective dormant BWP.

**[0331]** In an example, the plurality of second cells are in the non-dormant state or the second power state, wherein the each cell of the plurality of second cells is in the respective second non-dormant BWP.

**[0332]** In an example, the wireless device may stop monitoring for a DCI on a first cell of the one or more first cells or the plurality of second cells, wherein the first cell is in the dormant state.

**[0333]** In an example, the wireless device may continue performing measurements such as CSI and L1-RSRP on the first cell, wherein the first cell is in the dormant state.

**[0334]** In an example, the wireless device may maintain a primary cell of a first cell group, a special primary cell of a second cell group or a PUCCH cell of a PUCCH group in the non-dormant state in response to receiving the DCI.

**[0335]** In an example, a non-dormant BWP of a first cell, of the one or more first cells or the plurality of second cells, may be different from a dormant BWP of the first cell.

**[0336]** In an example, the DCI may be a scheduling DCI, wherein the DCI may comprise resource assignments for a downlink or an uplink data/signal.

**[0337]** In an example, the wireless device may activate a third cell in the non-dormant state, wherein a first active BWP configured for the third cell may be a dormant BWP of the third cell.

**[0338]** In an example, the one or more first cells and the plurality of second cells may belong to a same cell group.

**[0339]** In an example, the primary cell of the first cell group or the special primary cell of the second cell group or the PUCCH cell of the PUCCH group may belong to the same cell group.

**[0340]** In an example, a base station may configure the second respective dormant BWP for the each of the plurality of second cells via RRC messages, MAC CE messages and/or DCI messages.

**[0341]** In an example, the base station may configure the respective dormant BWP for the each of the one or more

first cells via RRC messages, MAC CE messages and/or DCI messages.

5 **[0342]** In an example, a wireless device may receive one or more radio resource control (RRC) messages comprising configuration parameters indicating a first secondary cell (SCell) group. The first SCell group may comprise a plurality of first cells. The wireless device may activate the plurality of first cells, wherein each cell of the plurality of first cells is in a first non-dormant bandwidth part (BWP) of the each cell. The wireless device may receive a downlink control information (DCI) indicating transitioning the first SCell group to a dormant state. In response to the DCI, the wireless device may transition from the respective first non-dormant BWP to the dormant BWP of the each cell of the plurality of first cells. The wireless device may maintain a primary cell of a cell group, wherein the plurality of first cells belongs to the cell group, in the non-dormant state.

10 **[0343]** In an example, a wireless device may receive one or more radio resource control (RRC) messages comprising configuration parameters indicating a first secondary cell (SCell) group. The first SCell group may comprise a plurality of first cells. The wireless device may activate the plurality of first cells, wherein each cell of the plurality of first cells is in a non-dormant state. The wireless device may receive a downlink control information (DCI) indicating transitioning the first SCell group to a dormant state. In response to the DCI, the wireless device may transition the plurality of first cells to the dormant state. The wireless device may maintain a primary cell of a cell group, wherein the plurality of first cells belongs to the cell group, in the non-dormant state.

15 **[0344]** In an example, a wireless device may receive one or more radio resource control (RRC) messages for a first cell. The one or more RRC messages may comprise a first scheduling cell and a first bandwidth part (BWP), wherein the first scheduling cell is the first cell. The one or more RRC messages may comprise a second scheduling cell and a second BWP, wherein the second scheduling cells is a second cell. The wireless device may receive a first command indicating a BWP switching to the first BWP of the first cell. The wireless device may switch to the first BWP in response to the receiving the first command. The wireless device may monitor a DCI on the first cell, wherein the DCI may comprise a resource assignment for the first BWP of the first cell. The wireless device may receive a second command indicating a BWP switching to the second BWP of the first cell from the first BWP. In response to the second command, the wireless device may switch to the second BWP of the first cell. In response to the switching, the wireless device may monitor a second DCI on the second cell, wherein the second DCI may comprise a resource assignment for the second BWP of the first cell.

20 **[0345]** In an example, a wireless device may receive one or more radio resource control (RRC) messages. The RRC messages may comprise a first control resource set (coreset) on a first cell and a second coreset on a second cell. The second coreset on the second cell may be for receiving a downlink control information (DCI) comprising a resource assignment of data on the first cell. The wireless device may monitor the first coreset on the first cell in response to the first cell being in a first state. The wireless device may receive a command indicating switching the first cell from the first state to a second state. In response to the command, the wireless device may monitor the second coreset on the second cell for receiving a second DCI comprising a resource assignment of data on the first cell. In response to the command, the wireless device may stop monitoring the first coreset on the first cell. The wireless device may receive the second DCI on the second cell during the monitoring the second coreset, wherein the second DCI may indicate a resource assignment for the first cell. In response to the second DCI, the wireless device may start monitoring the first coreset on the first cell. In response to the second DCI, the wireless device may stop monitoring the second coreset for receiving a DCI comprising a resource assignment of data for the first cell.

25 **[0346]** Embodiments may be configured to operate as needed. The disclosed mechanism may be performed when certain criteria are met, for example, in a wireless device, a base station, a radio environment, a network, a combination of the above, and/or the like. Example criteria may be based, at least in part, on for example, wireless device or network node configurations, traffic load, initial system set up, packet sizes, traffic characteristics, a combination of the above, and/or the like. When the one or more criteria are met, various example embodiments may be applied. Therefore, it may be possible to implement example embodiments that selectively implement disclosed protocols.

30 **[0347]** A base station may communicate with a mix of wireless devices. Wireless devices and/or base stations may support multiple technologies, and/or multiple releases of the same technology. Wireless devices may have some specific capability(ies) depending on wireless device category and/or capability(ies). A base station may comprise multiple sectors. When this disclosure refers to a base station communicating with a plurality of wireless devices, this disclosure may refer to a subset of the total wireless devices in a coverage area. This disclosure may refer to, for example, a plurality of wireless devices of a given LTE or 5G release with a given capability and in a given sector of the base station. The plurality of wireless devices in this disclosure may refer to a selected plurality of wireless devices, and/or a subset of total wireless devices in a coverage area which perform according to disclosed methods, and/or the like. There may be a plurality of base stations or a plurality of wireless devices in a coverage area that may not comply with the disclosed methods, for example, because those wireless devices or base stations perform based on older releases of LTE or 5G technology.

35 **[0348]** In this disclosure, "a" and "an" and similar phrases are to be interpreted as "at least one" and "one or more." Similarly, any term that ends with the suffix "(s)" is to be interpreted as "at least one" and "one or more." In this disclosure,

the term "may" is to be interpreted as "may, for example." In other words, the term "may" is indicative that the phrase following the term "may" is an example of one of a multitude of suitable possibilities that may, or may not, be employed to one or more of the various embodiments.

5 **[0349]** If A and B are sets and every element of A is also an element of B, A is called a subset of B. In this specification, only non-empty sets and subsets are considered. For example, possible subsets of  $B = \{\text{cell1}, \text{cell2}\}$  are:  $\{\text{cell1}\}$ ,  $\{\text{cell2}\}$ , and  $\{\text{cell1}, \text{cell2}\}$ . The phrase "based on" (or equally "based at least on") is indicative that the phrase following the term "based on" is an example of one of a multitude of suitable possibilities that may, or may not, be employed to one or more of the various embodiments. The phrase "in response to" (or equally "in response at least to") is indicative that the phrase following the phrase "in response to" is an example of one of a multitude of suitable possibilities that may, or may not, be employed to one or more of the various embodiments. The phrase "depending on" (or equally "depending at least to") is indicative that the phrase following the phrase "depending on" is an example of one of a multitude of suitable possibilities that may, or may not, be employed to one or more of the various embodiments. The phrase "employing/using" (or equally "employing/using at least") is indicative that the phrase following the phrase "employing/using" is an example of one of a multitude of suitable possibilities that may, or may not, be employed to one or more of the various embodiments.

10 **[0350]** The term configured may relate to the capacity of a device whether the device is in an operational or non-operational state. Configured may also refer to specific settings in a device that effect the operational characteristics of the device whether the device is in an operational or non-operational state. In other words, the hardware, software, firmware, registers, memory values, and/or the like may be "configured" within a device, whether the device is in an operational or nonoperational state, to provide the device with specific characteristics. Terms such as "a control message to cause in a device" may mean that a control message has parameters that may be used to configure specific characteristics or may be used to implement certain actions in the device, whether the device is in an operational or non-operational state.

15 **[0351]** In this disclosure, various embodiments are disclosed. Limitations, features, and/or elements from the disclosed example embodiments may be combined to create further embodiments within the scope of the disclosure.

20 **[0352]** In this disclosure, parameters (or equally called, fields, or Information elements: IEs) may comprise one or more information objects, and an information object may comprise one or more other objects. For example, if parameter (IE) N comprises parameter (IE) M, and parameter (IE) M comprises parameter (IE) K, and parameter (IE) K comprises parameter (information element) J. Then, for example, N comprises K, and N comprises J. In an example embodiment, when one or more messages comprise a plurality of parameters, it implies that a parameter in the plurality of parameters is in at least one of the one or more messages, but does not have to be in each of the one or more messages.

25 **[0353]** Furthermore, many features presented above are described as being optional through the use of "may" or the use of parentheses. For the sake of brevity and legibility, the present disclosure does not explicitly recite each and every permutation that may be obtained by choosing from the set of optional features. However, the present disclosure is to be interpreted as explicitly disclosing all such permutations. For example, a system described as having three optional features may be embodied in seven different ways, namely with just one of the three possible features, with any two of the three possible features or with all three of the three possible features.

30 **[0354]** Many of the elements described in the disclosed embodiments may be implemented as modules. A module is defined here as an element that performs a defined function and has a defined interface to other elements. The modules described in this disclosure may be implemented in hardware, software in combination with hardware, firmware, wetware (e.g. hardware with a biological element) or a combination thereof, all of which may be behaviorally equivalent. For example, modules may be implemented as a software routine written in a computer language configured to be executed by a hardware machine (such as C, C++, Fortran, Java, Basic, Matlab or the like) or a modeling/simulation program such as Simulink, Stateflow, GNU Octave, or LabVIEWMathScript. Additionally, it may be possible to implement modules using physical hardware that incorporates discrete or programmable analog, digital and/or quantum hardware. Examples of programmable hardware comprise: computers, microcontrollers, microprocessors, application-specific integrated circuits (ASICs); field programmable gate arrays (FPGAs); and complex programmable logic devices (CPLDs). Computers, microcontrollers and microprocessors are programmed using languages such as assembly, C, C++ or the like. FPGAs, ASICs and CPLDs are often programmed using hardware description languages (HDL) such as VHSIC hardware description language (VHDL) or Verilog that configure connections between internal hardware modules with lesser functionality on a programmable device. The above mentioned technologies are often used in combination to achieve the result of a functional module.

35 **[0355]** The disclosure of this patent document incorporates material which is subject to copyright protection. The copyright owner has no objection to the facsimile reproduction by anyone of the patent document or the patent disclosure, as it appears in the Patent and Trademark Office patent file or records, for the limited purposes required by law, but otherwise reserves all copyright rights whatsoever.

40 **[0356]** While various embodiments have been described above, it should be understood that they have been presented by way of example, and not limitation. It will be apparent to persons skilled in the relevant art(s) that various changes in form and detail may be made therein without departing from the scope. In fact, after reading the above description, it

will be apparent to one skilled in the relevant art(s) how to implement alternative embodiments. Thus, the present embodiments should not be limited by any of the above described exemplary embodiments.

[0357] In addition, it should be understood that any figures which highlight the functionality and advantages, are presented for example purposes only. The disclosed architecture is sufficiently flexible and configurable, such that it may be utilized in ways other than that shown. For example, the actions listed in any flowchart may be re-ordered or only optionally used in some embodiments.

[0358] Further, the purpose of the Abstract of the Disclosure is to enable the U.S. Patent and Trademark Office and the public generally, and especially the scientists, engineers and practitioners in the art who are not familiar with patent or legal terms or phraseology, to determine quickly from a cursory inspection the nature and essence of the technical disclosure of the application. The Abstract of the Disclosure is not intended to be limiting as to the scope in any way.

[0359] Finally, it is the applicant's intent that only claims that include the express language "means for" or "step for" be interpreted under 35 U.S.C. 112. Claims that do not expressly include the phrase "means for" or "step for" are not to be interpreted under 35 U.S.C. 112.

## Claims

### 1. A method comprising:

receiving, by a wireless device, one or more radio resource control (RRC) messages comprising configuration parameters indicating:

a first secondary cell (SCell) group comprising one or more first cells; and  
a second SCell group comprising a plurality of second cells;

activating, in a non-dormant state, the one or more first cells and the plurality of second cells; and  
in response to receiving a downlink control information indicating transitioning the first SCell group to a dormant state:

transitioning the one or more first cells to the dormant state; and  
maintaining the plurality of second cells in the non-dormant state.

2. The method of claim 1, wherein transitioning a cell to the dormant state comprises transitioning from a non-dormant BWP of the cell to a dormant BWP of the cell as an active BWP.

3. The method of claim 2, wherein the non-dormant BWP of the cell is different from the dormant BWP of the cell.

4. The method of claim 1, wherein an active BWP of a cell in the non-dormant state is a non-dormant BWP.

5. The method of claim 1, wherein the one or more first cells and the plurality of second cells are activated serving cells of the wireless device.

### 6. A wireless device comprising:

one or more processors; and  
memory storing instructions that, when executed by the one or more processors, cause the wireless device to perform the method of any one of claims 1 to 5.

7. A non-transitory computer-readable medium comprising instructions that, when executed by one or more processors, cause the one or more processors to perform the method of any one of claims 1 to 5.

### 8. A method comprising:

transmitting, by a base station, one or more radio resource control (RRC) messages comprising configuration parameters indicating:

a first secondary cell (SCell) group comprising one or more first cells; and  
a second SCell group comprising a plurality of second cells;

transmitting one or more commands activating, in a non-dormant state, the one or more first cells and the plurality of second cells; and  
determining to transition the first SCell group to a dormant state and maintain the plurality of second cells in the non-dormant state; and  
5 in response to the determining, transmitting a downlink control information indicating transitioning of the first SCell group to the dormant state.

9. The method of claim 8, wherein transitioning a cell to the dormant state comprises transitioning from a non-dormant BWP of the cell to a dormant BWP of the cell as an active BWP.

10. The method of claim 9, wherein the non-dormant BWP of the cell is different from the dormant BWP of the cell.

11. The method of claim 8, wherein an active BWP of a cell in the non-dormant state is a non-dormant BWP.

12. The method of claim 8, wherein the one or more first cells and the plurality of second cells are activated serving cells of a wireless device.

13. A base station comprising:

20 one or more processors; and  
memory storing instructions that, when executed by the one or more processors, cause the base station to perform the method of any one of claims 8 to 12.

14. A non-transitory computer-readable medium comprising instructions that, when executed by one or more processors, cause the one or more processors to perform the method of any one of claims 8 to 12.

15. A system comprising:

a wireless device comprising:

30 one or more first processors; and  
a first memory storing first instructions that, when executed by the one or more first processors, cause the wireless device to:

35 receive one or more radio resource control (RRC) messages comprising configuration parameters indicating:

a first secondary cell (SCell) group comprising one or more first cells; and  
a second SCell group comprising a plurality of second cells;

40 activate, in a non-dormant state, the one or more first cells and the plurality of second cells; and  
in response to receiving a downlink control information indicating transitioning the first SCell group to a dormant state:

45 transition the one or more first cells to the dormant state; and  
maintain the plurality of second cells in the non-dormant state; and

a base station comprising:

50 one or more second processors; and  
a second memory storing second instructions that, when executed by the one or more second processors, cause the base station to transmit to the wireless device:

55 the one or more RRC messages; and  
the downlink control information.

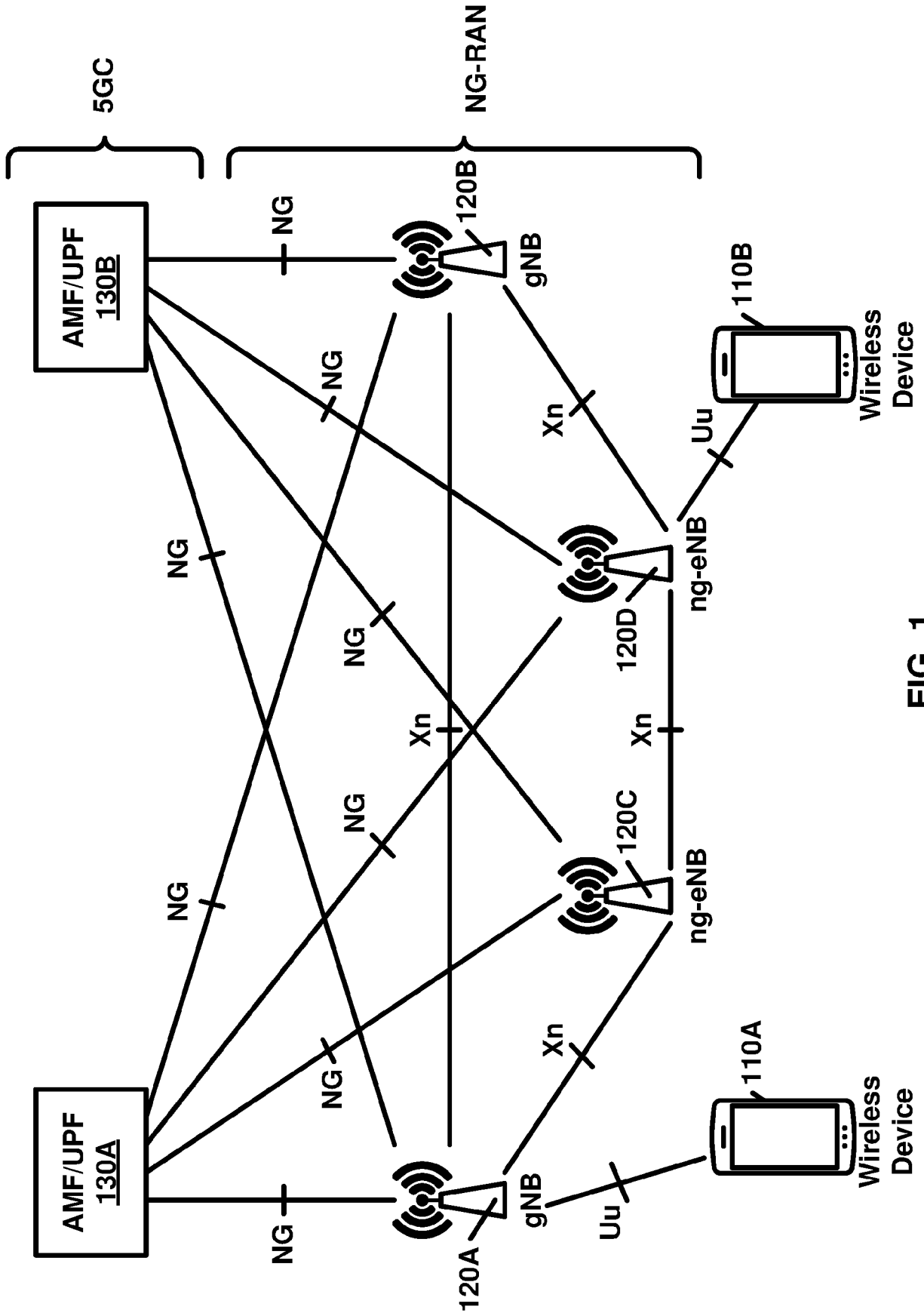

FIG. 1

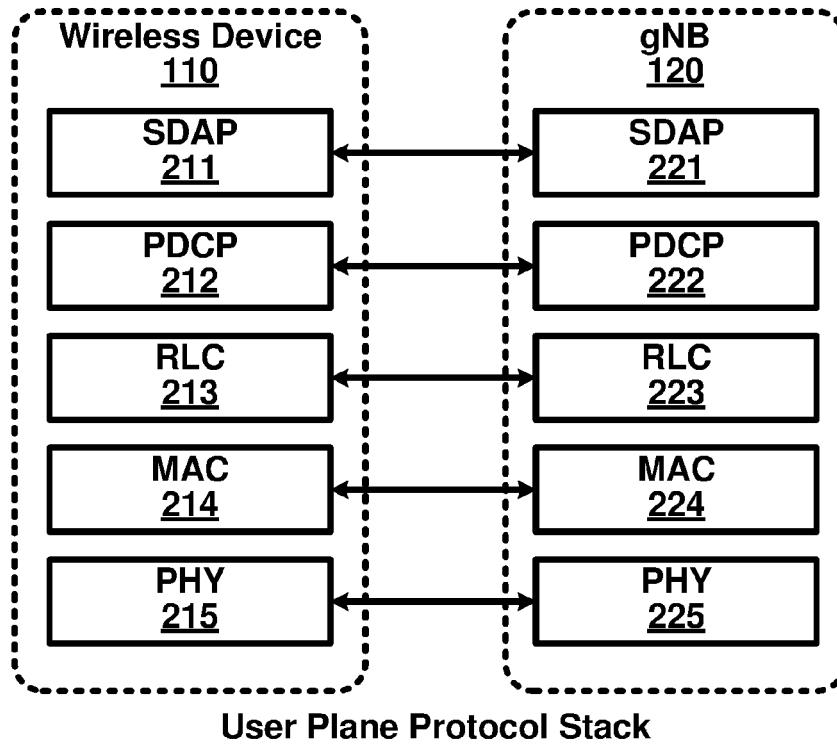

FIG. 2A

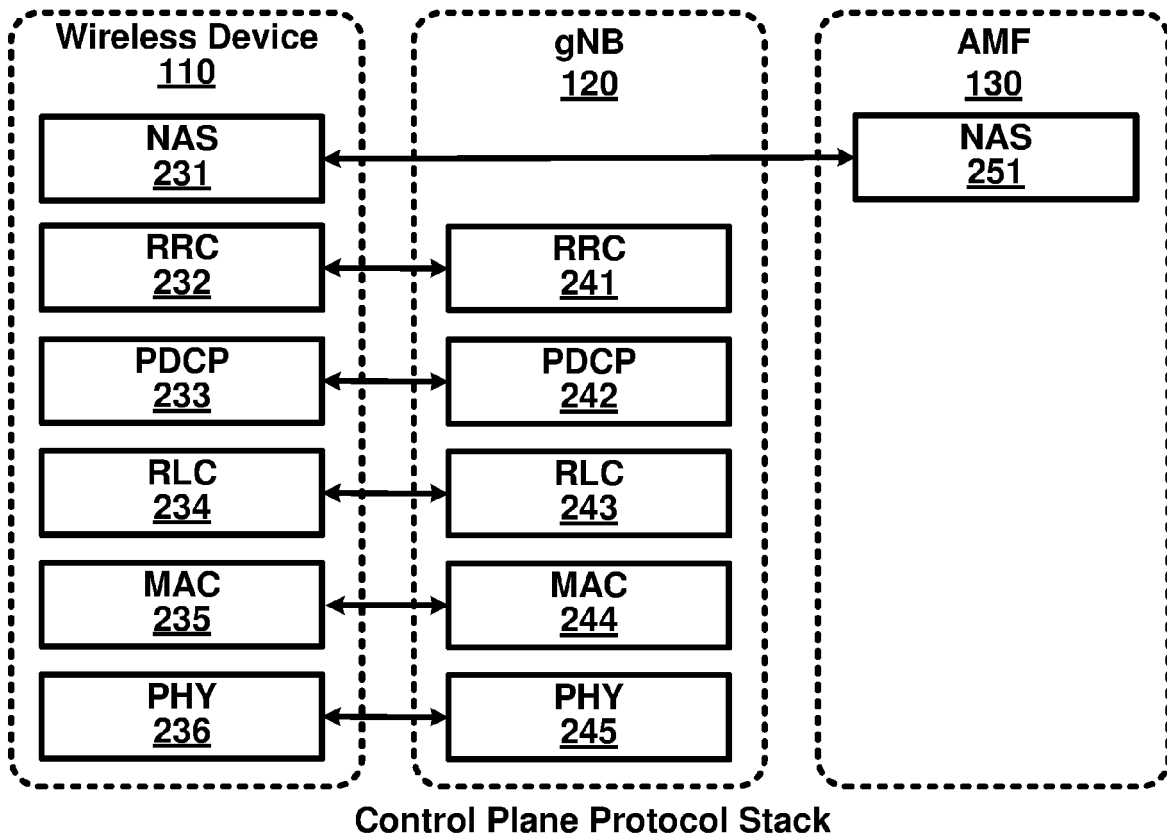

FIG. 2B

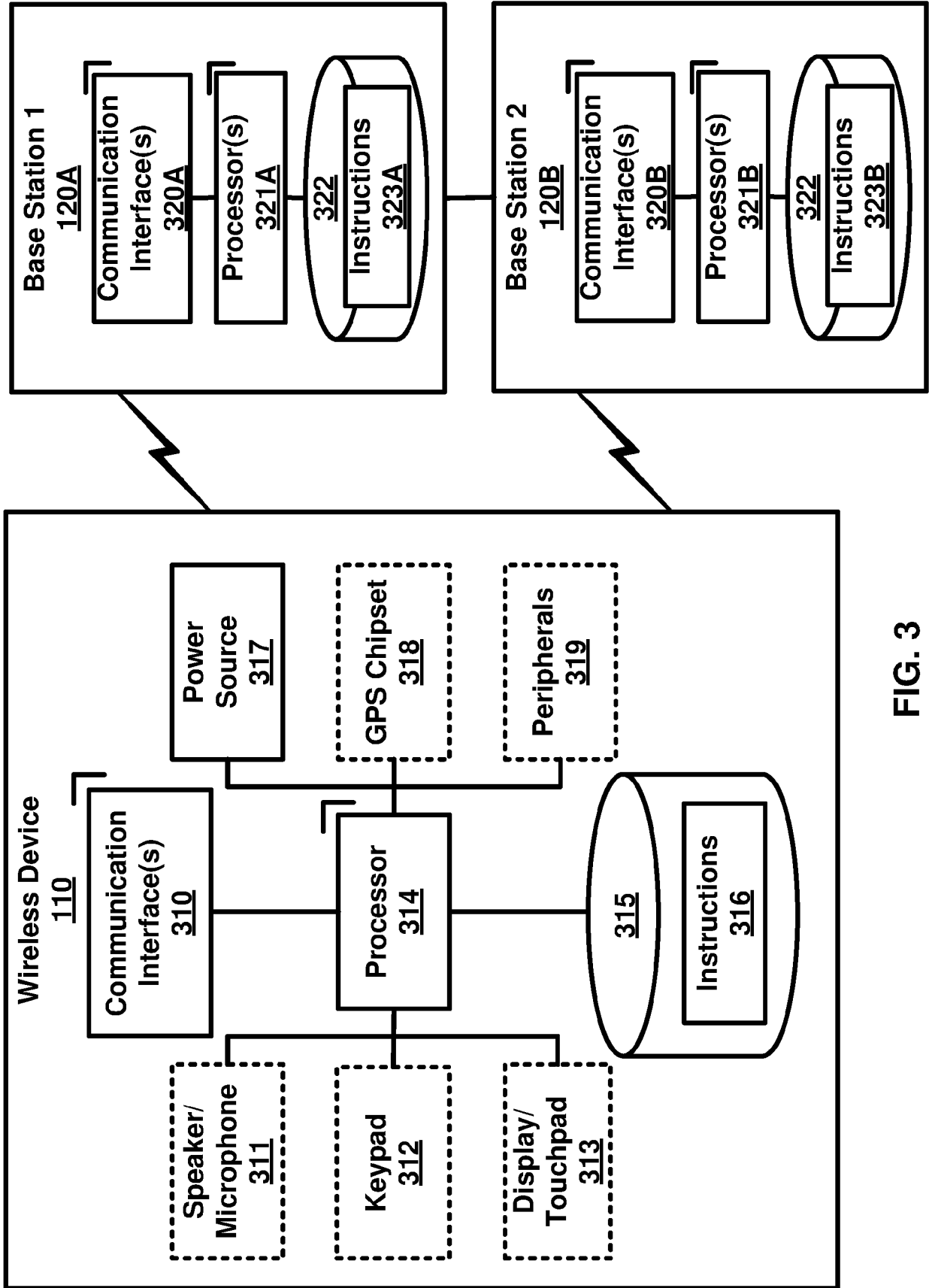

FIG. 3

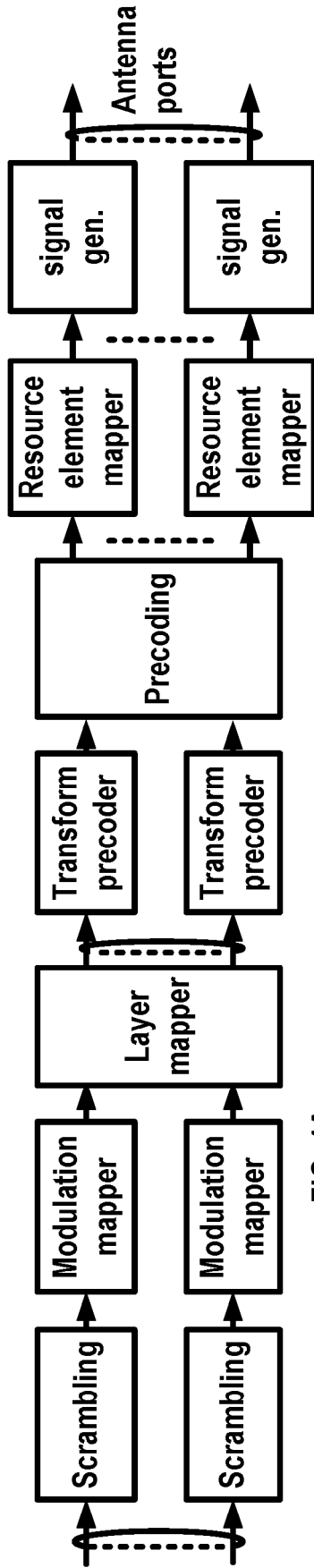

FIG. 4A

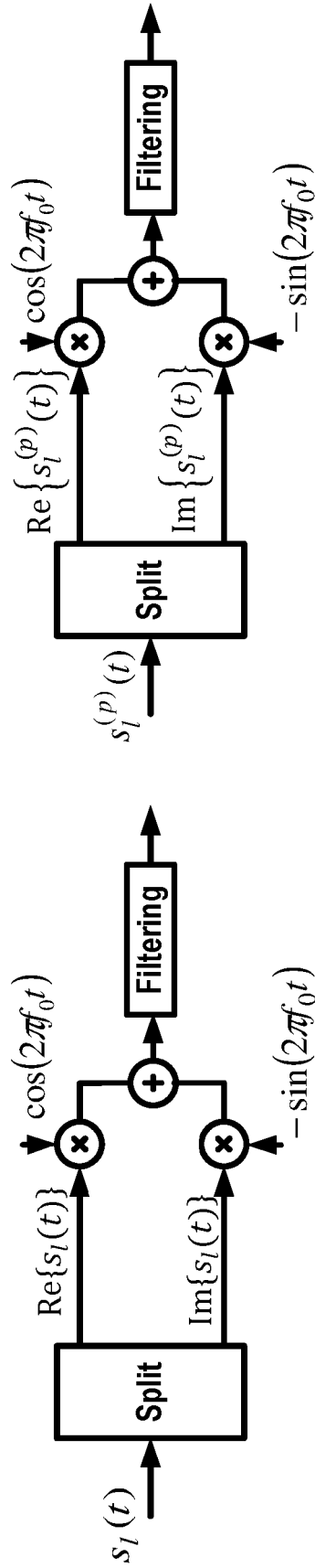

FIG. 4B

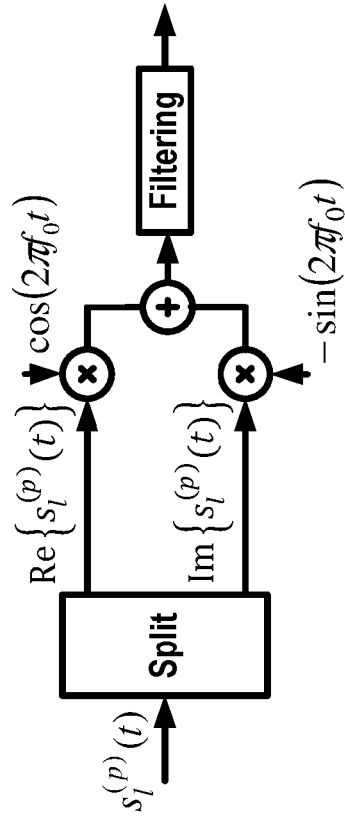

FIG. 4D

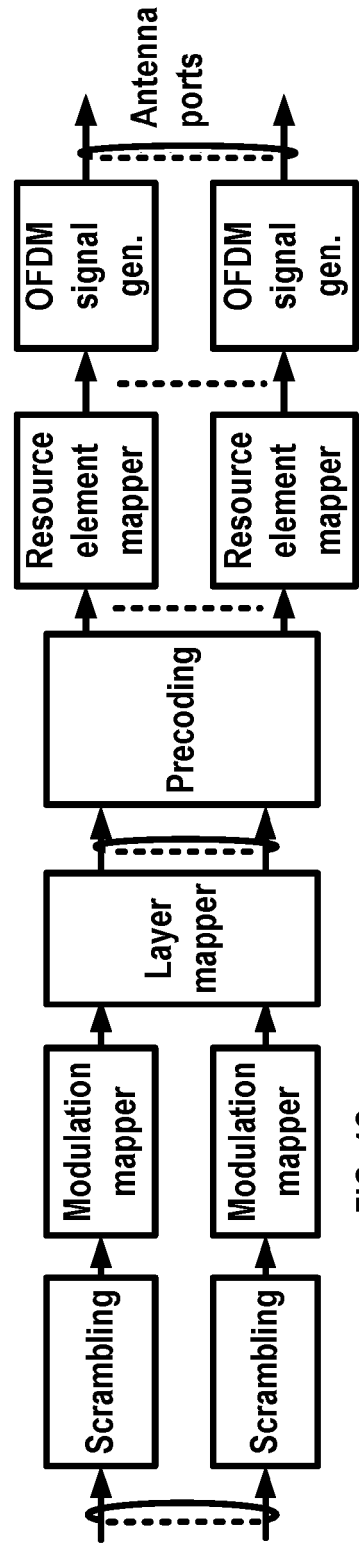

FIG. 4C

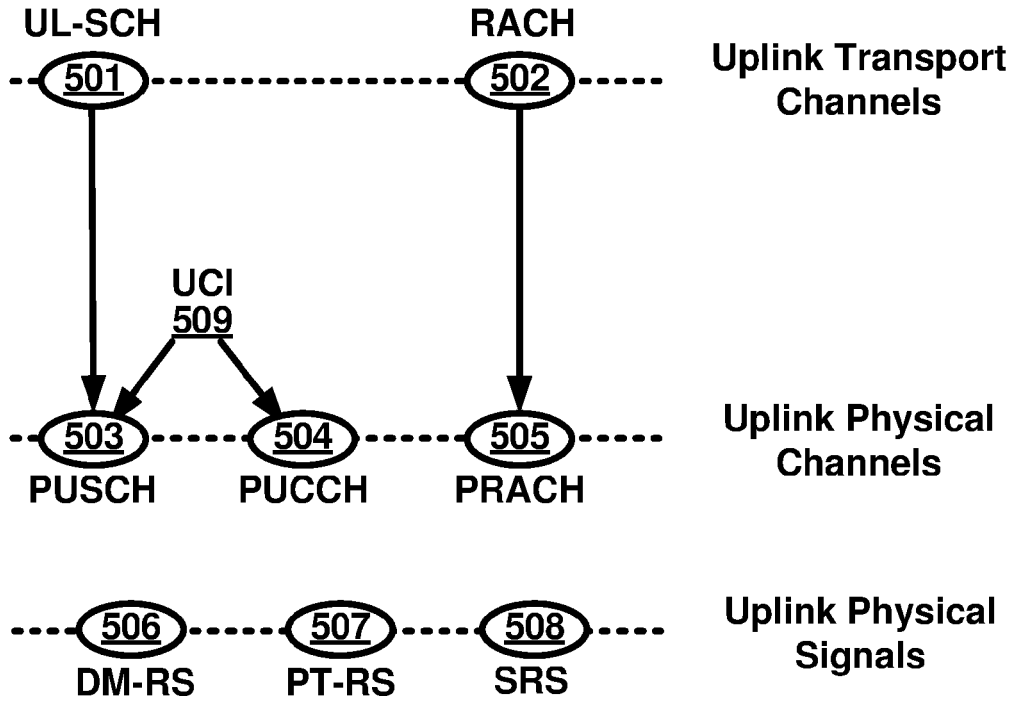

FIG. 5A

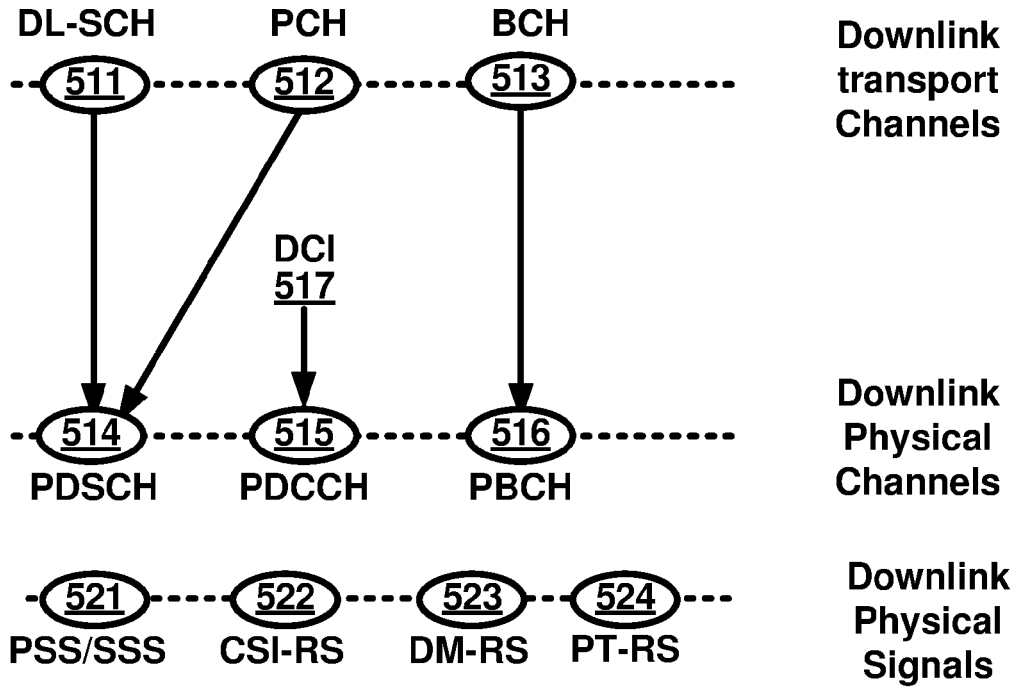

FIG. 5B

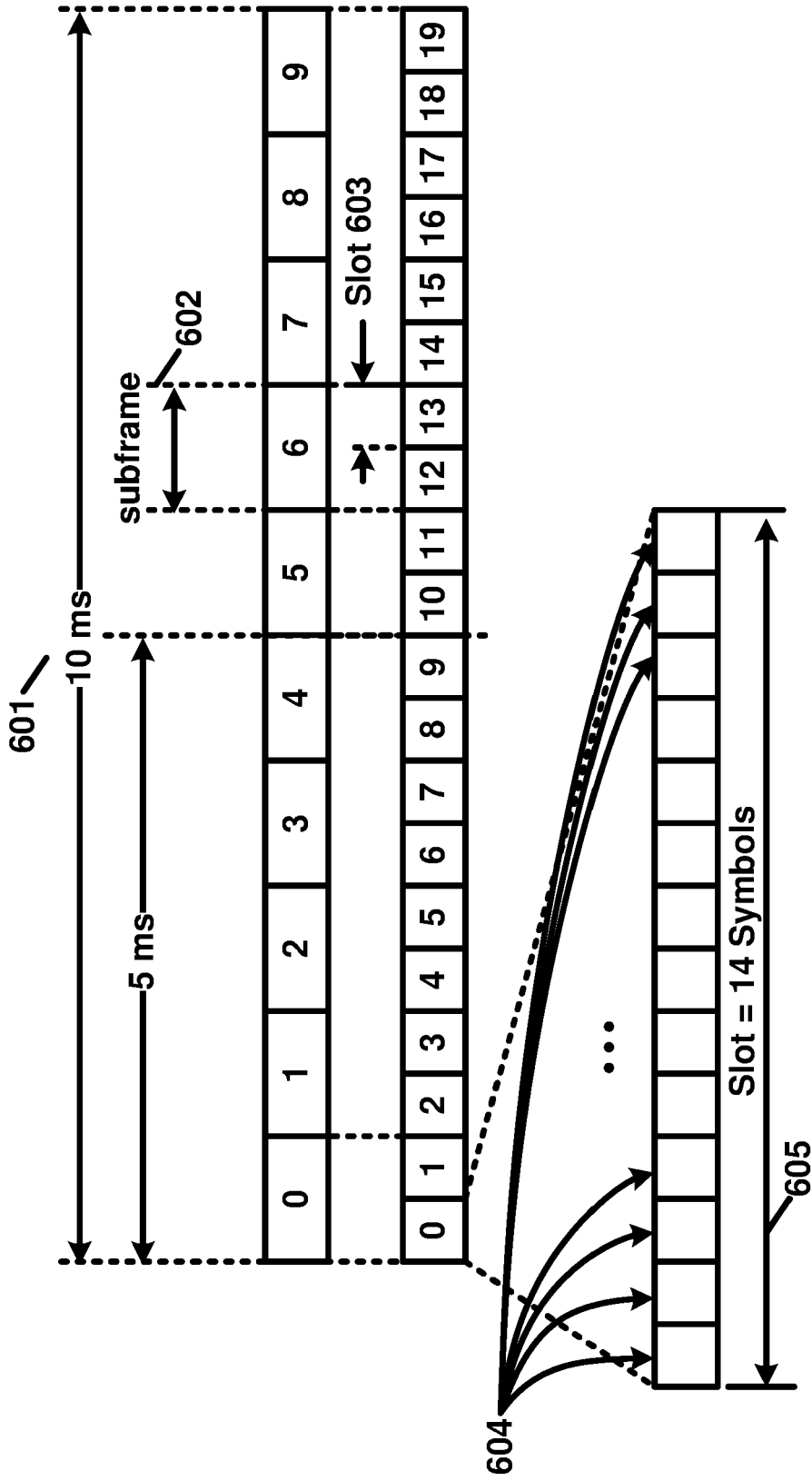

FIG. 6

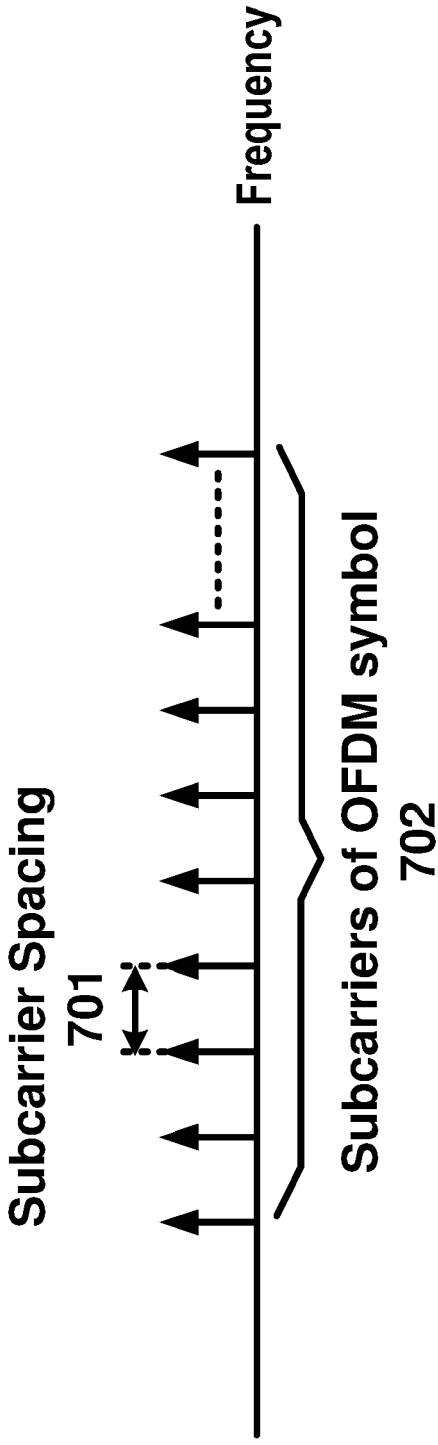

FIG. 7A

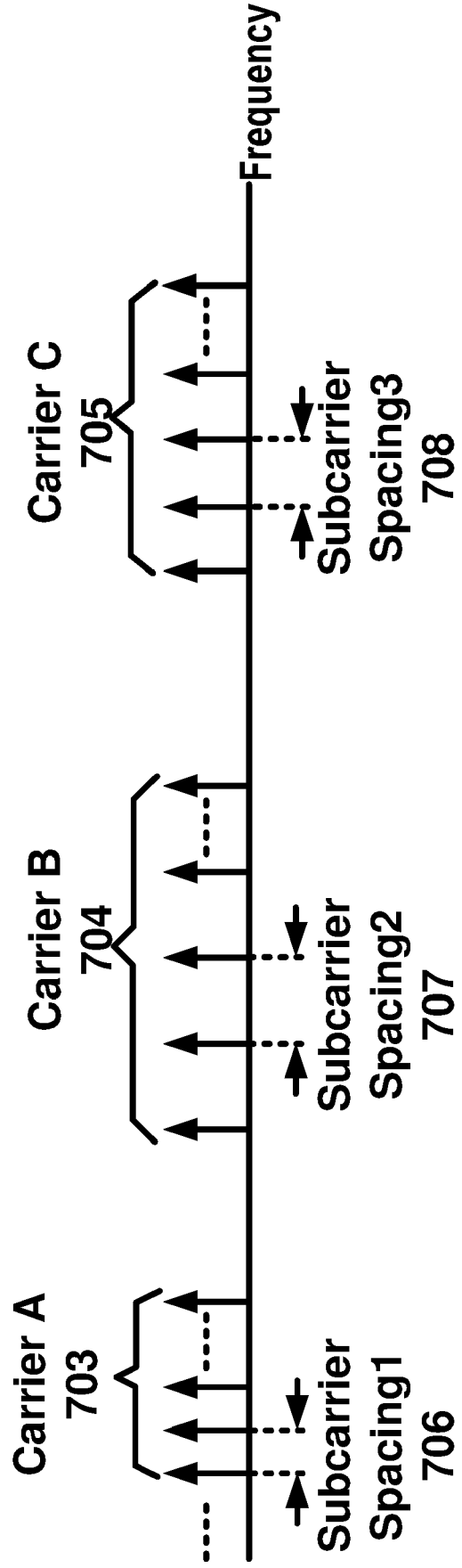

FIG. 7B

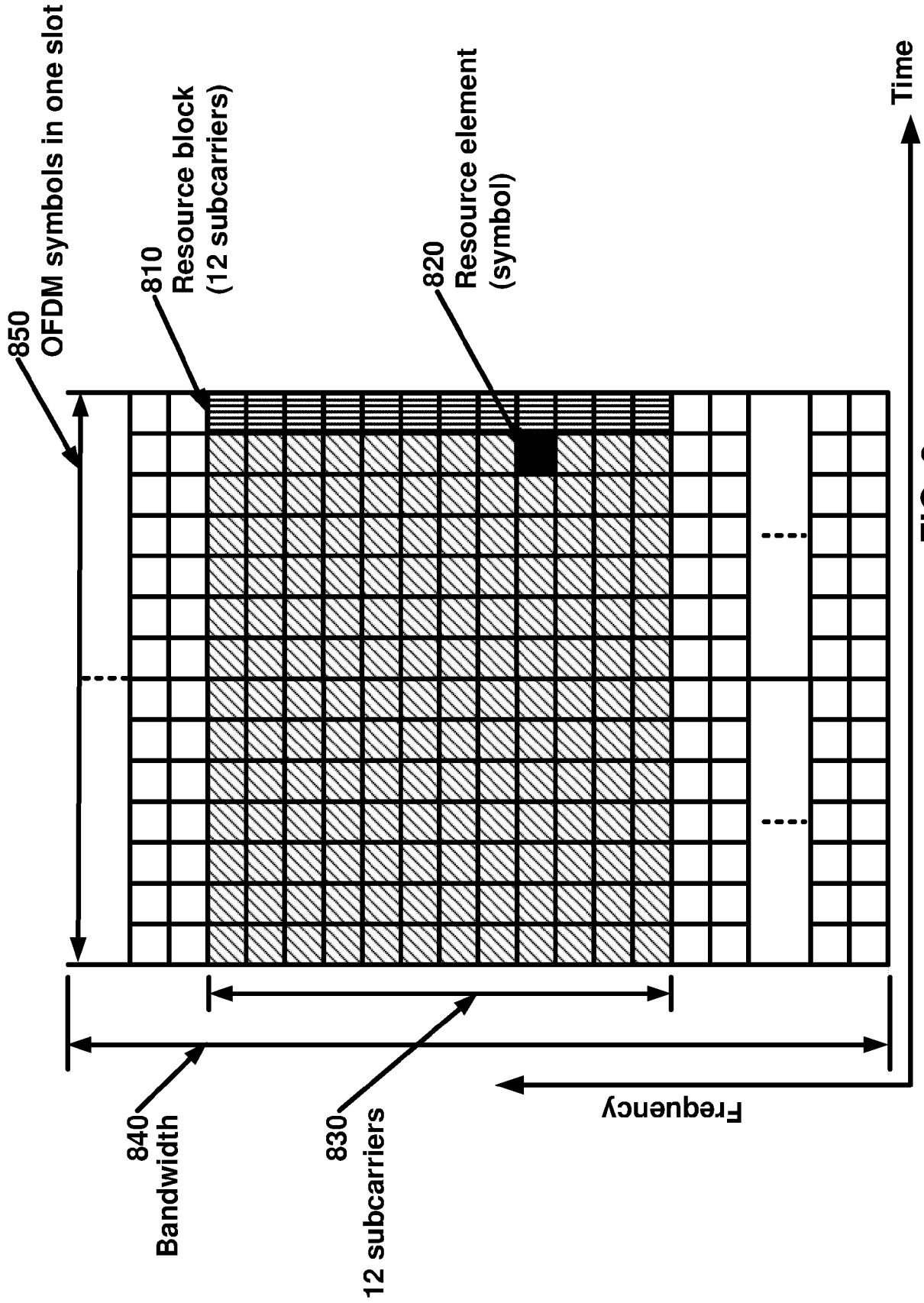

FIG. 8

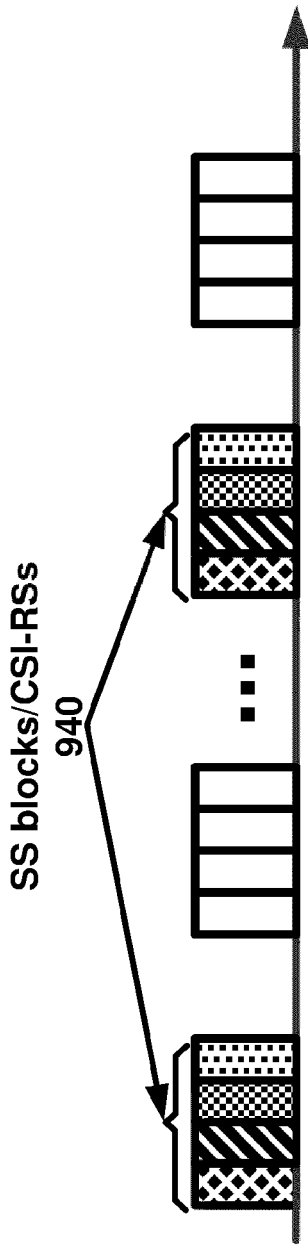

FIG. 9A

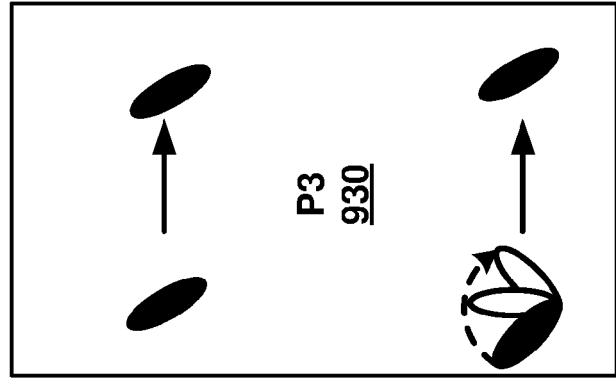
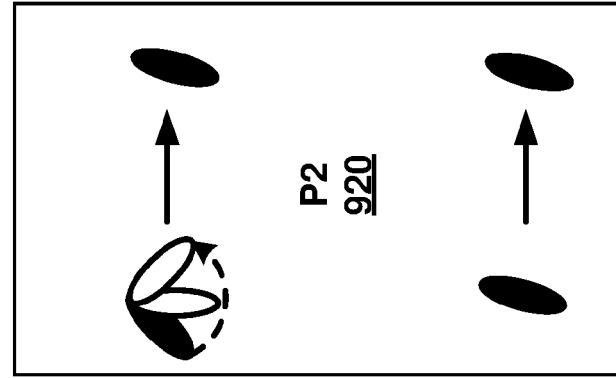
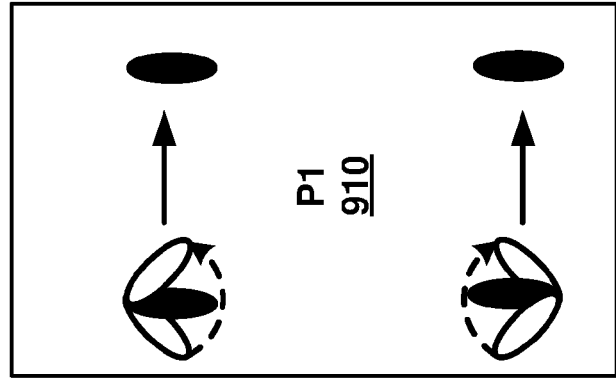
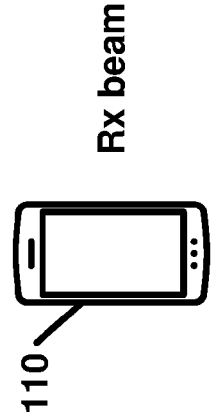
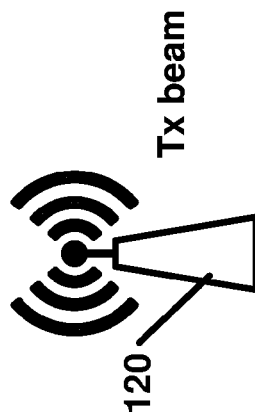
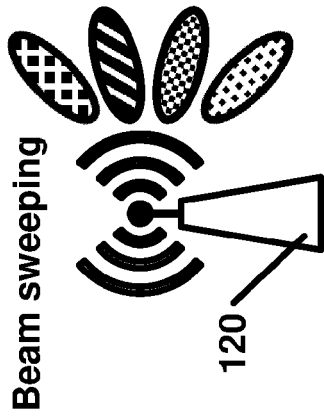

FIG. 9B

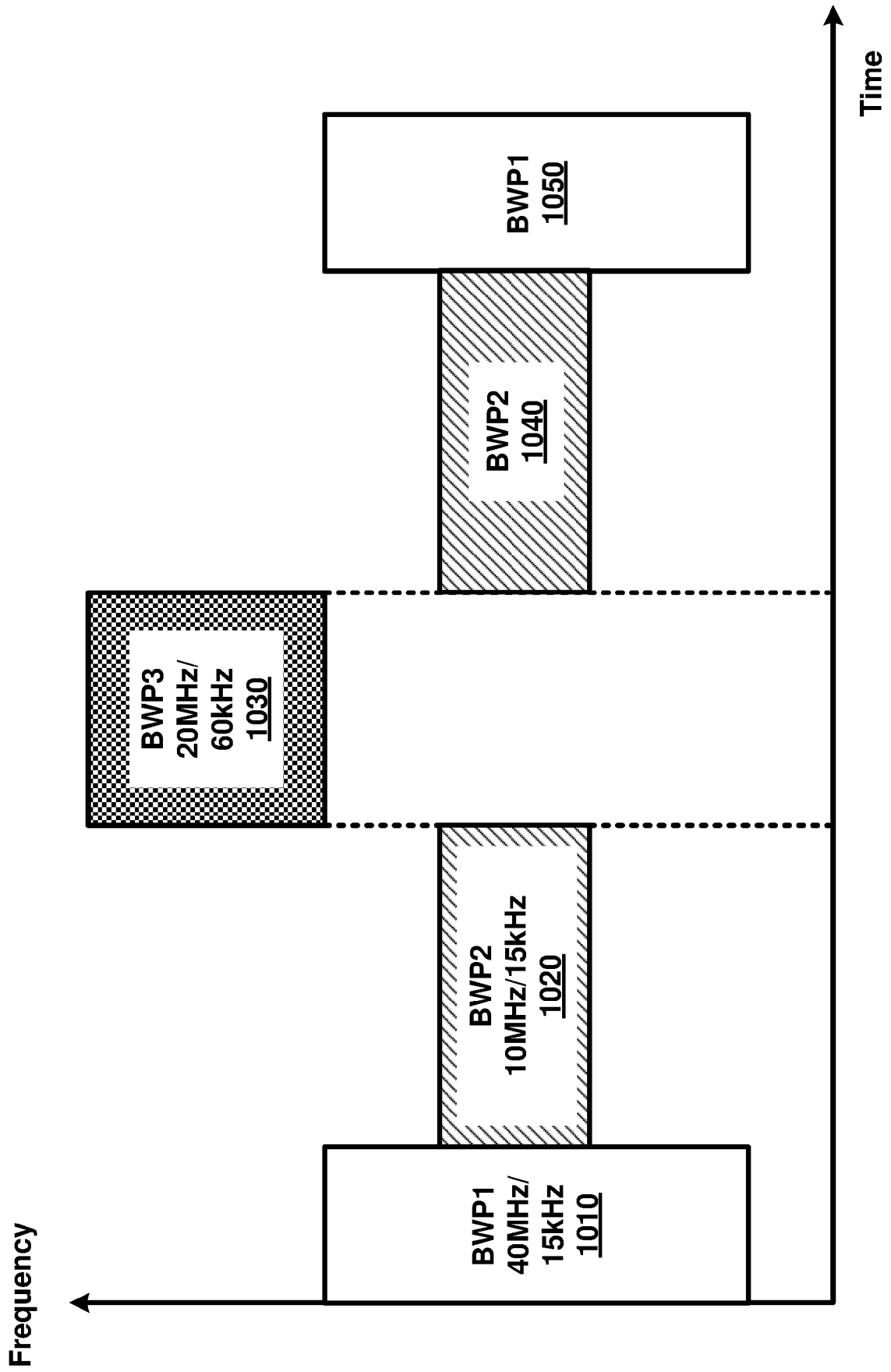

FIG. 10

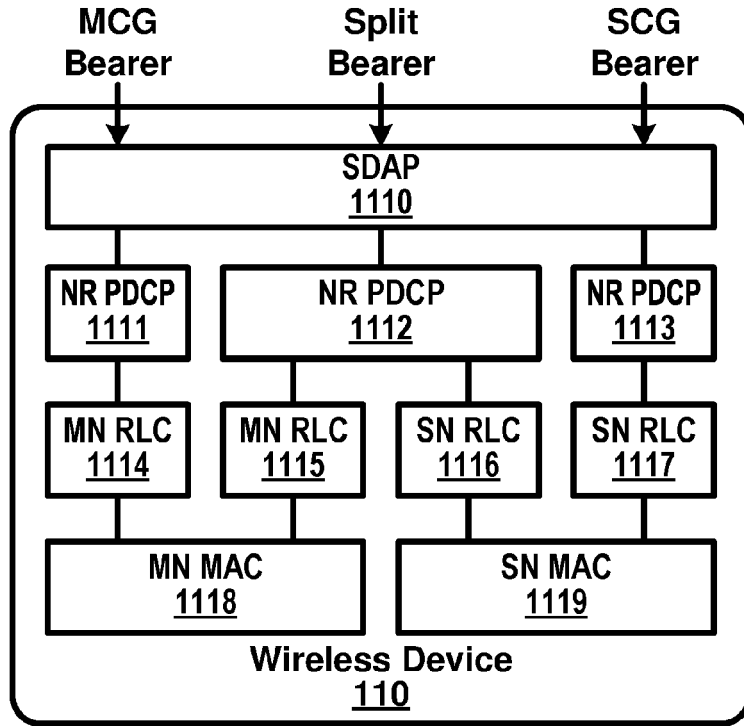

FIG. 11A

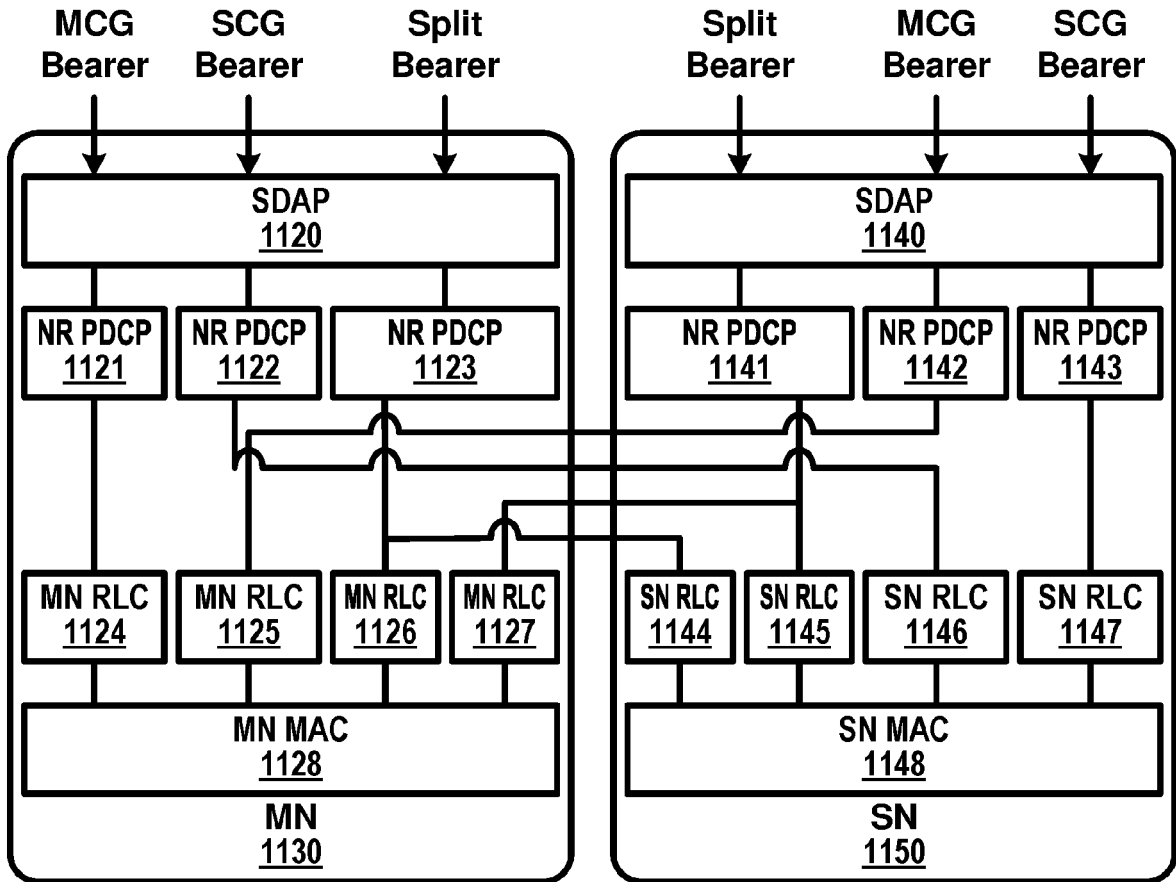

FIG. 11B

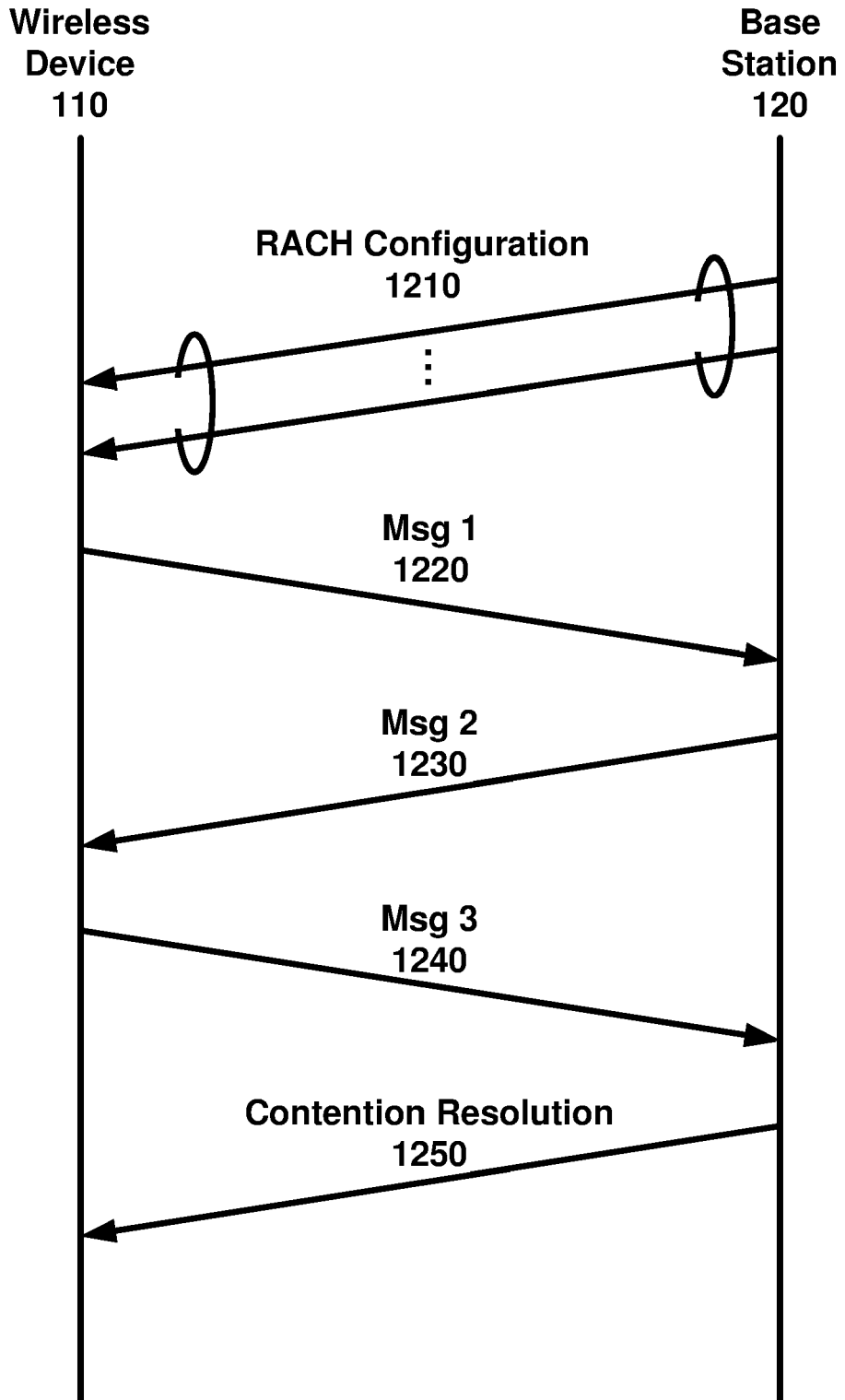

FIG. 12

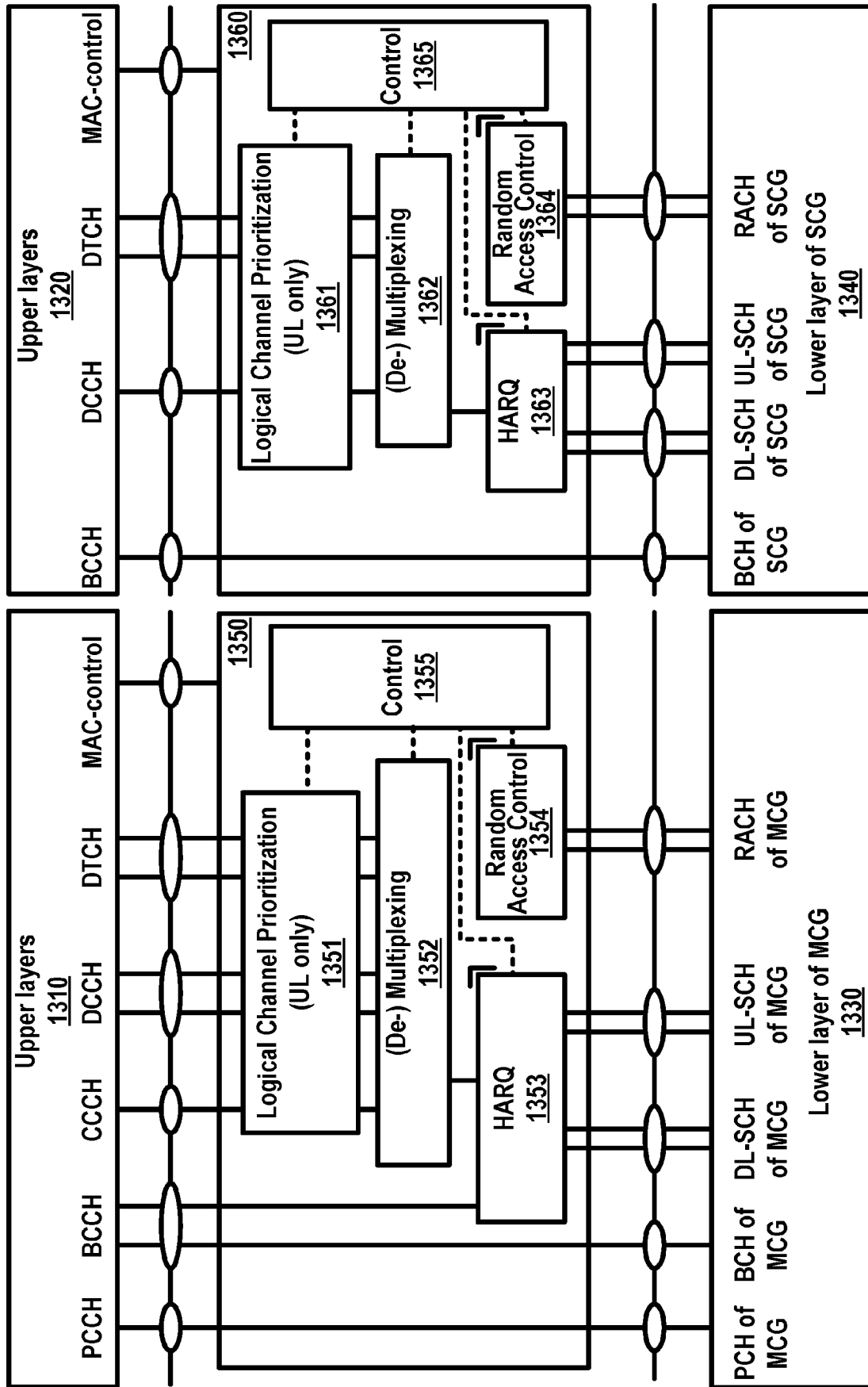

FIG. 13

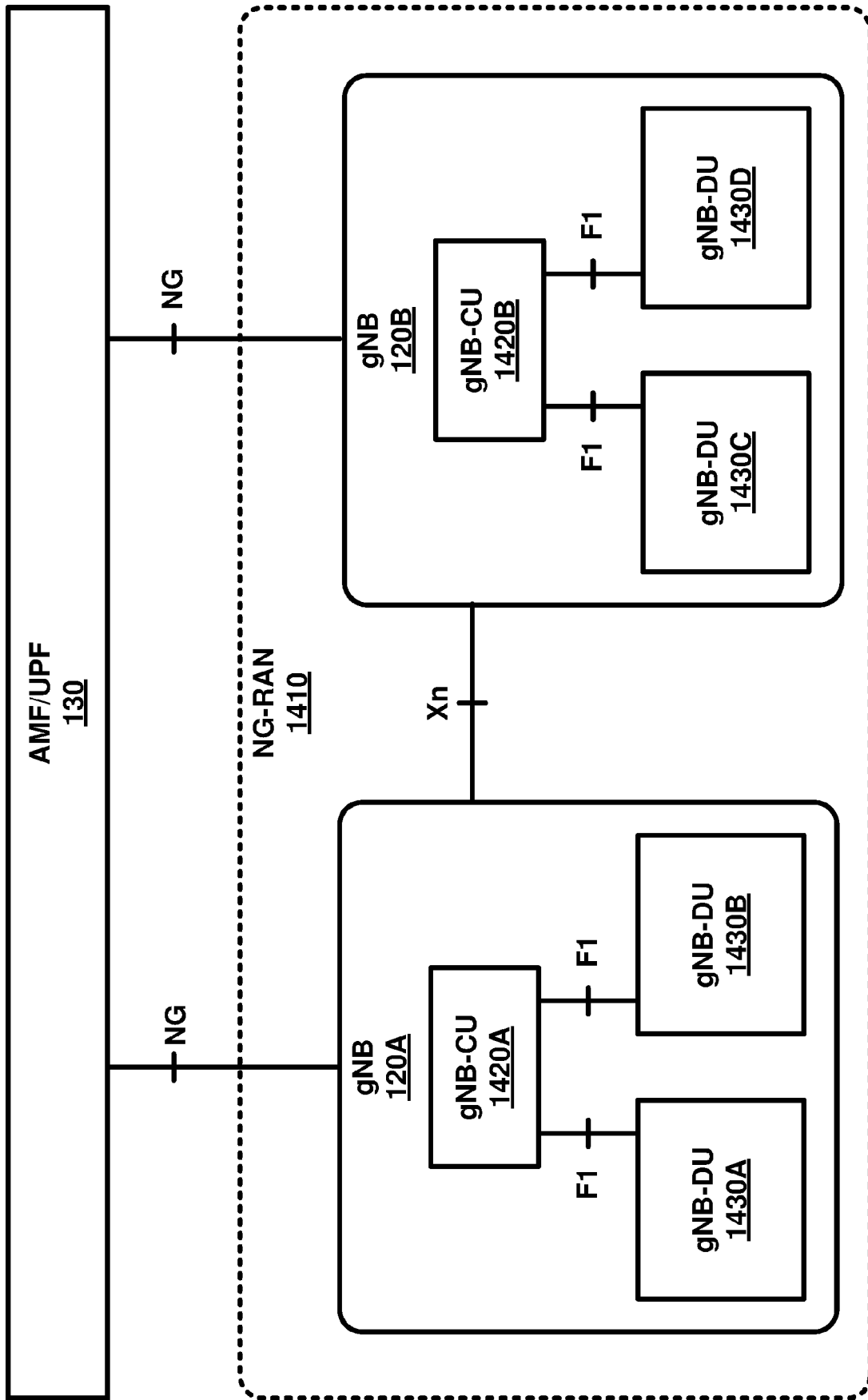

FIG. 14

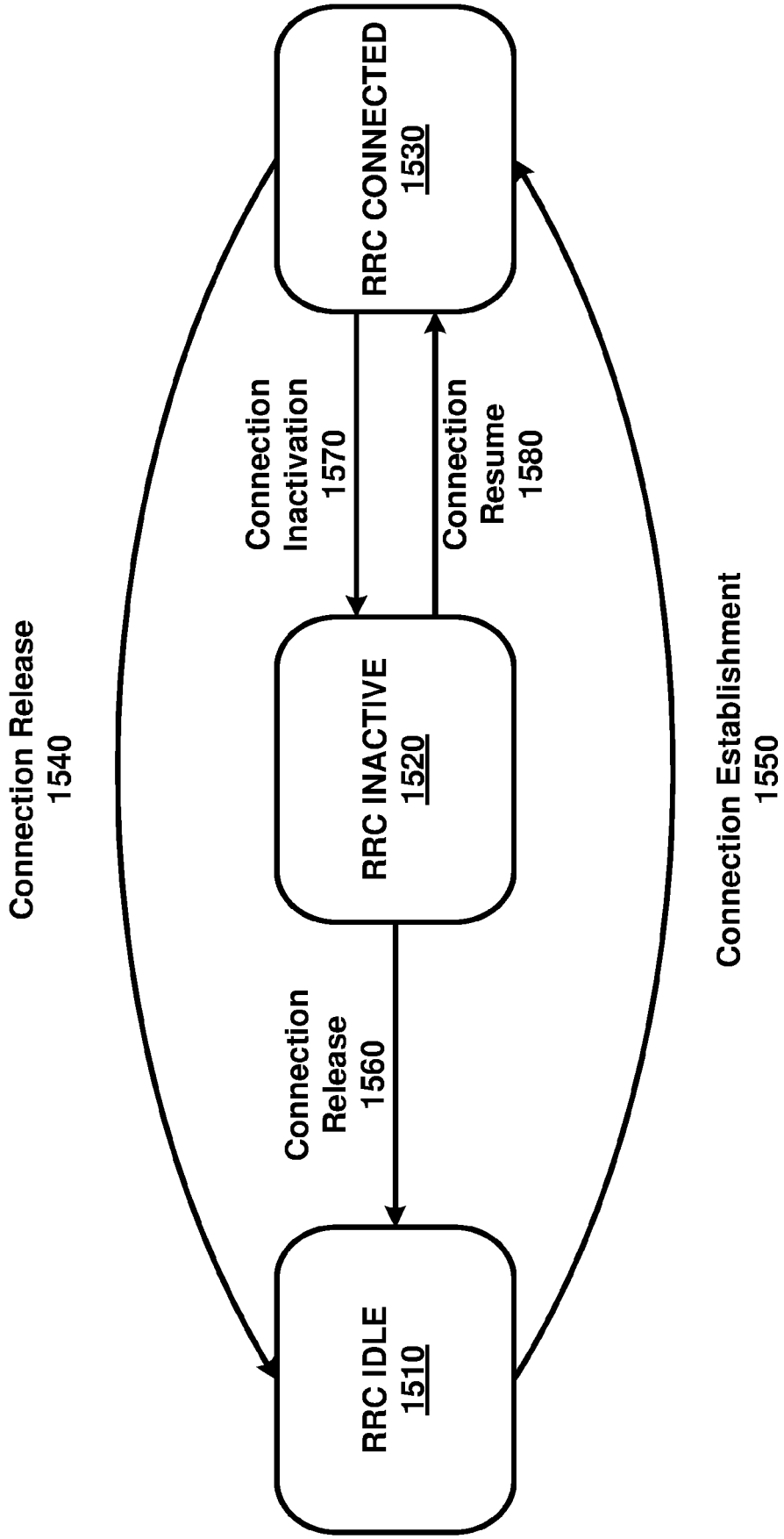
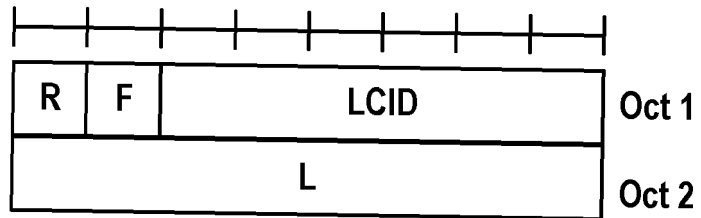
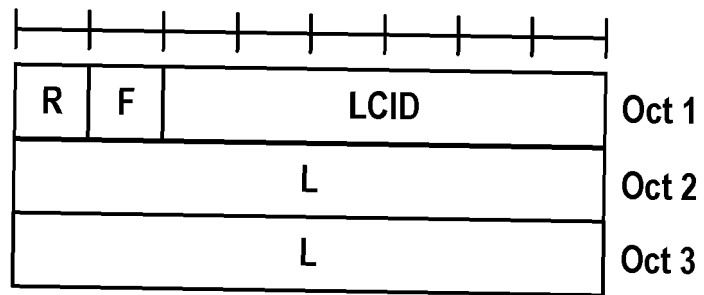

FIG. 15



**FIG. 16A**



**FIG. 16B**

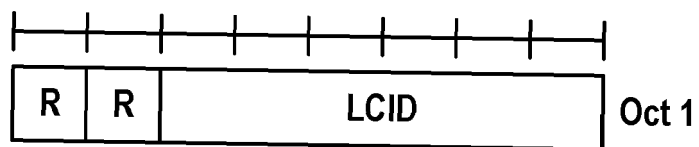

**FIG. 16C**

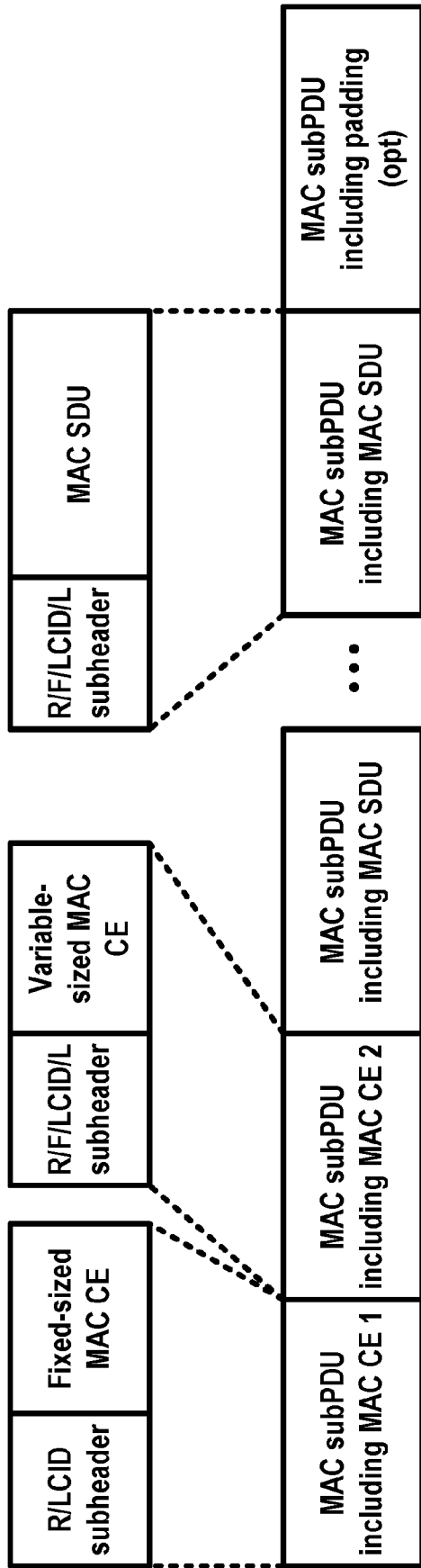

FIG. 17A

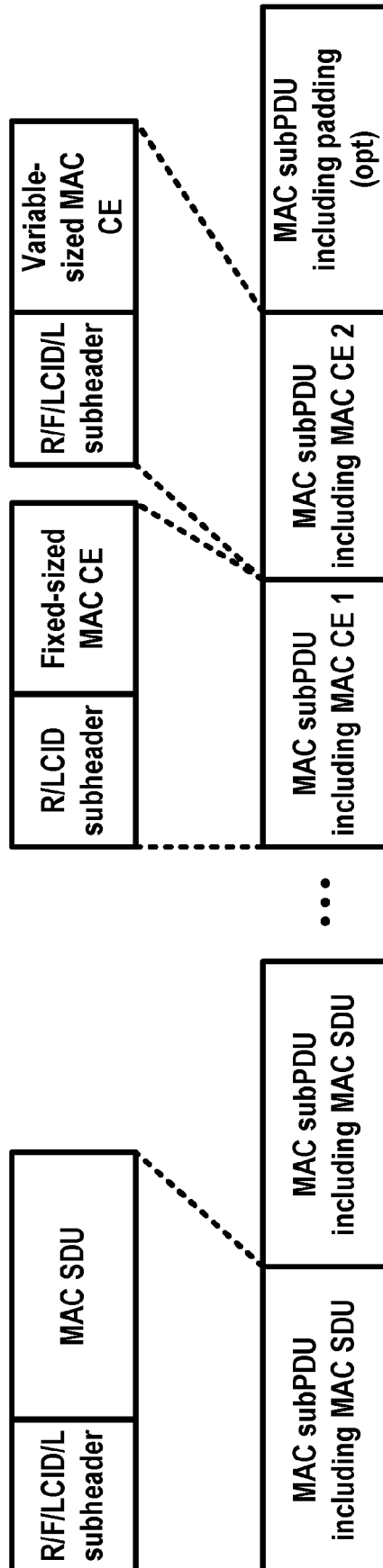

FIG. 17B

<b>Index</b>	<b>LCID values</b>
<b>000000</b>	<b>CCCH</b>
<b>000001-100000</b>	<b>Identity of a logical channel</b>
<b>100001-101111</b>	<b>Reserved</b>
<b>110000</b>	<b>SP ZP CSI-RS Resource Set Act./Deact.</b>
<b>110001</b>	<b>PUCCH spatial relation Act./Deact.</b>
<b>110010</b>	<b>SP SRS Act./Deact.</b>
<b>110011</b>	<b>SP CSI reporting on PUCCH Act./Deact.</b>
<b>110100</b>	<b>TCI State Indication for UE-specific PDCCH</b>
<b>110101</b>	<b>TCI State Indication for UE-specific PDSCH</b>
<b>110110</b>	<b>Aperiodic CSI Trigger State Subselection</b>
<b>110111</b>	<b>SP CSI-RS/CSI-IM Resource Set Act./Deact.</b>
<b>111000</b>	<b>Duplication Activation/deactivation</b>
<b>111001</b>	<b>SCell activation/deactivation (4 Octet)</b>
<b>111010</b>	<b>SCell activation/deactivation (1 Octet)</b>
<b>111011</b>	<b>Long DRX Command</b>
<b>111100</b>	<b>DRX Command</b>
<b>111101</b>	<b>Timing Advance Command</b>
<b>111110</b>	<b>UE Contention Resolution Identity</b>
<b>111111</b>	<b>Padding</b>

**FIG. 18**

<b>Index</b>	<b>LCID values</b>
<b>000000</b>	<b>CCCH</b>
<b>000001-100000</b>	<b>Identity of a logical channel</b>
<b>100001-110110</b>	<b>Reserved</b>
<b>110111</b>	<b>Configured Grant Confirmation</b>
<b>111000</b>	<b>Multiple Entry PHR</b>
<b>111001</b>	<b>Single Entry PHR</b>
<b>111010</b>	<b>C-RNTI</b>
<b>111011</b>	<b>Short Truncated BSR</b>
<b>111100</b>	<b>Long Truncated BSR</b>
<b>111101</b>	<b>Short BSR</b>
<b>111110</b>	<b>Long BSR</b>
<b>111111</b>	<b>Padding</b>

**FIG. 19**

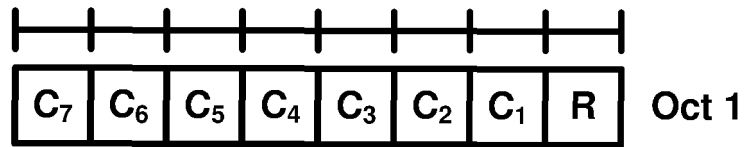

FIG. 20A

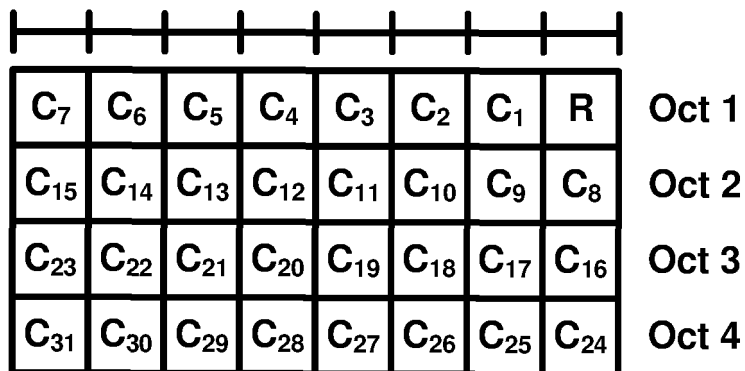

FIG. 20B

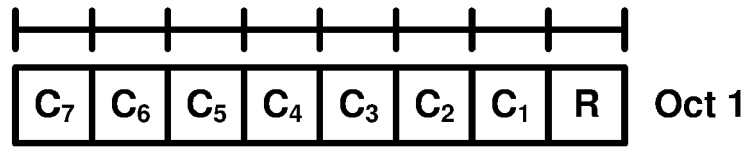

FIG. 21A

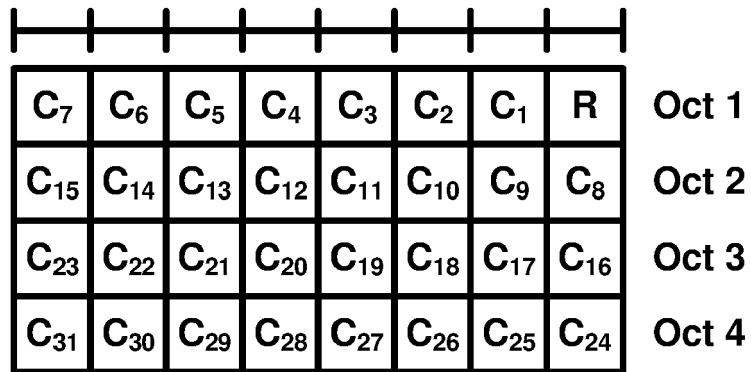

FIG. 21B

Hibernation MAC CE $C_i$	Activation/ Deactivation MAC CE $C_i$	SCell may be
0	0	Deactivated
0	1	Activated
1	0	Reserved MAC CE combination
1	1	Dormant

FIG. 21C

	DCI format	Example size (Bits)	Usage
Uplink	0	45	Uplink scheduling grant
	4	53	Uplink scheduling grant with spatial multiplexing
	6-0A, 6-0B	46, 36	Uplink scheduling grant for eMTC devices
Downlink	1C	31	Special purpose compact assignment
	1A	45	Contiguous allocation only
	1B	46	Codebook-based beamforming using CRS
	1D	46	MU-MIMO using CRS
	1	55	Flexible allocations
	2A	64	Open-loop spatial multiplexing using CRS
	2B	64	Dual-layer transmission using DM-RS (TM8)
	2C	66	Multi-layer transmission using DM-RS (TM9)
	2D	68	Multi-layer transmission using DM-RS (TM9)
	2	67	Closed-loop spatial multiplexing using CRS
	6-1A, 6-1B	46, 36	Downlink scheduling grants for eMTC devices
Special	3, 3A	45	Power control commands
	5		Sidelink operation
	6-2		Paging/direct indication for eMTC devices

FIG. 22

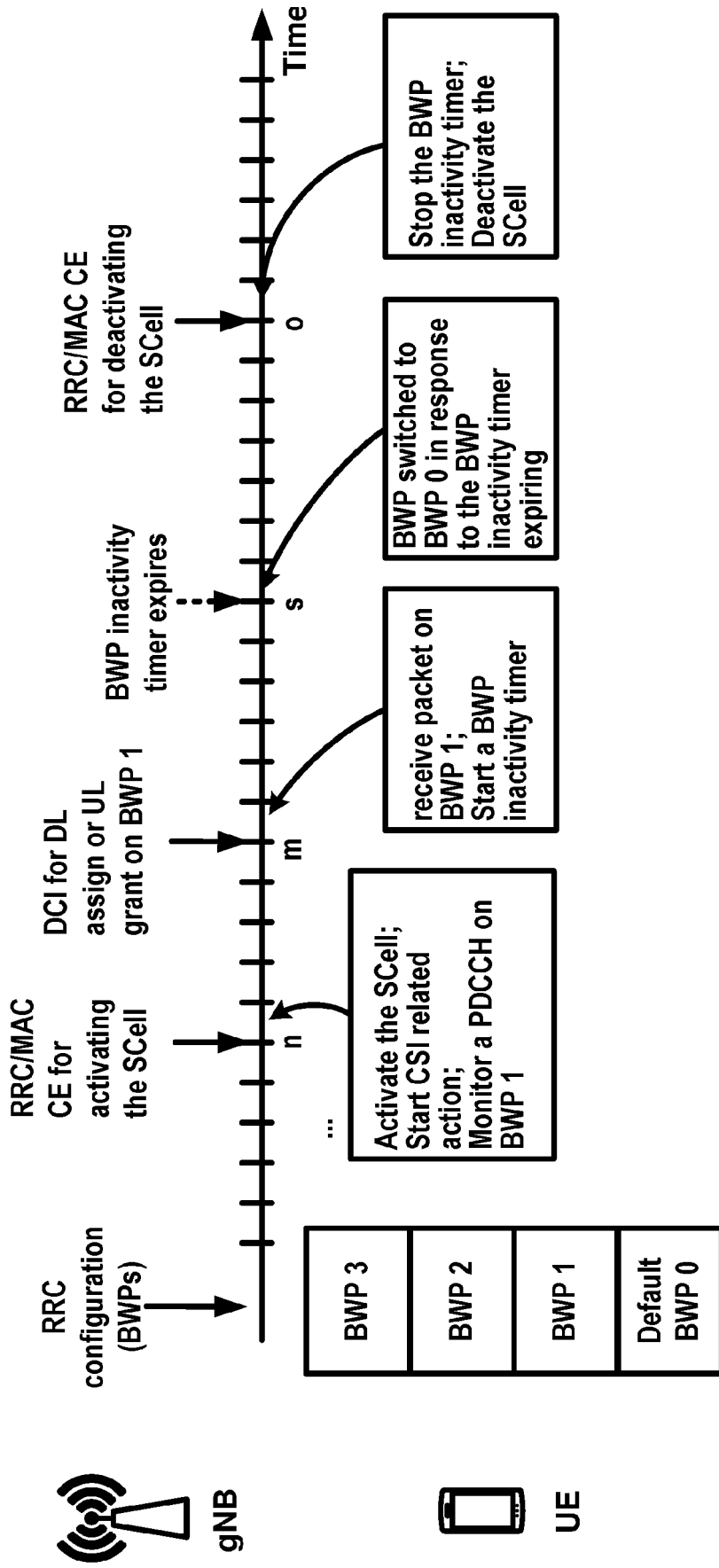

FIG. 23

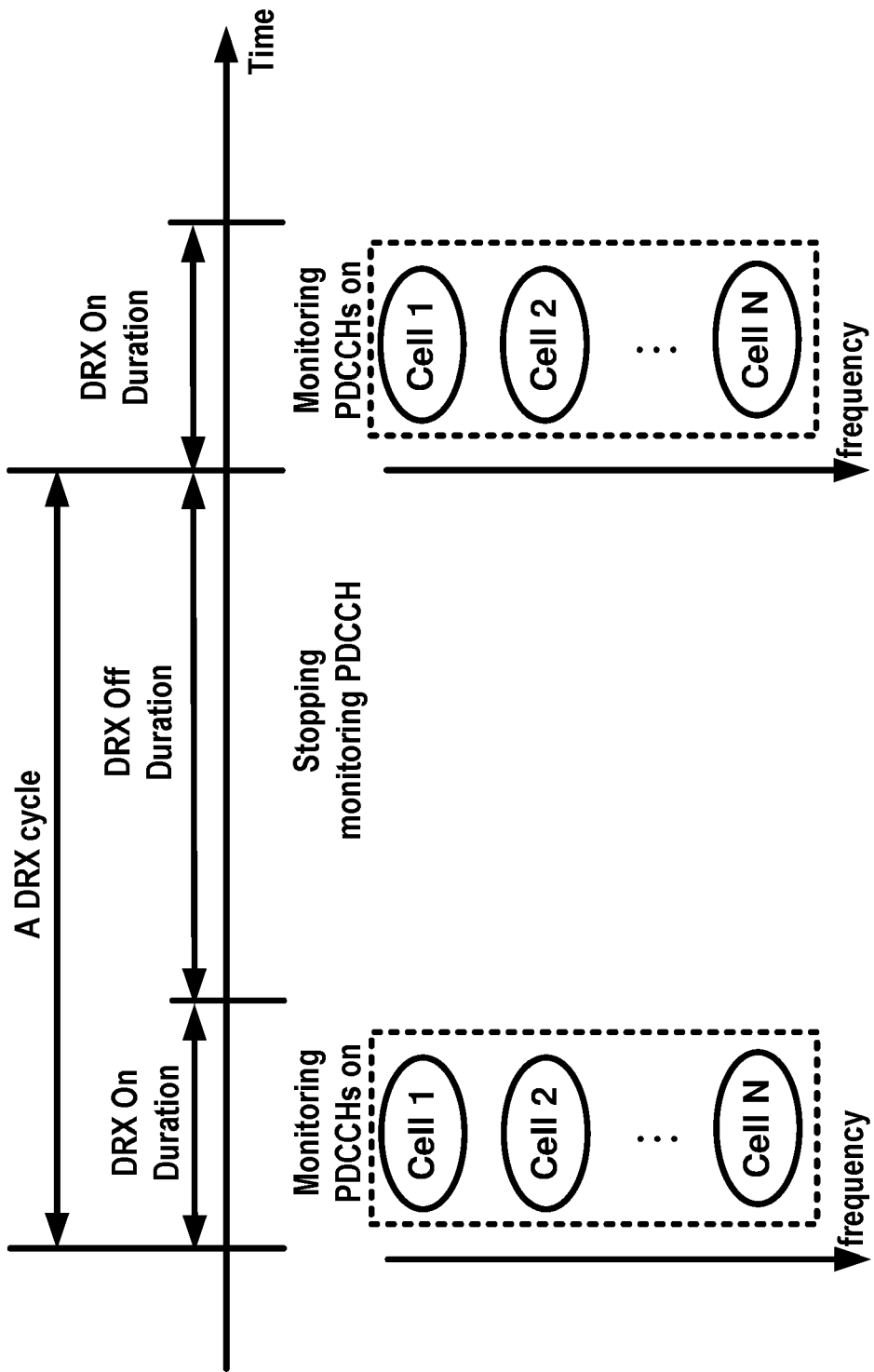

FIG. 24

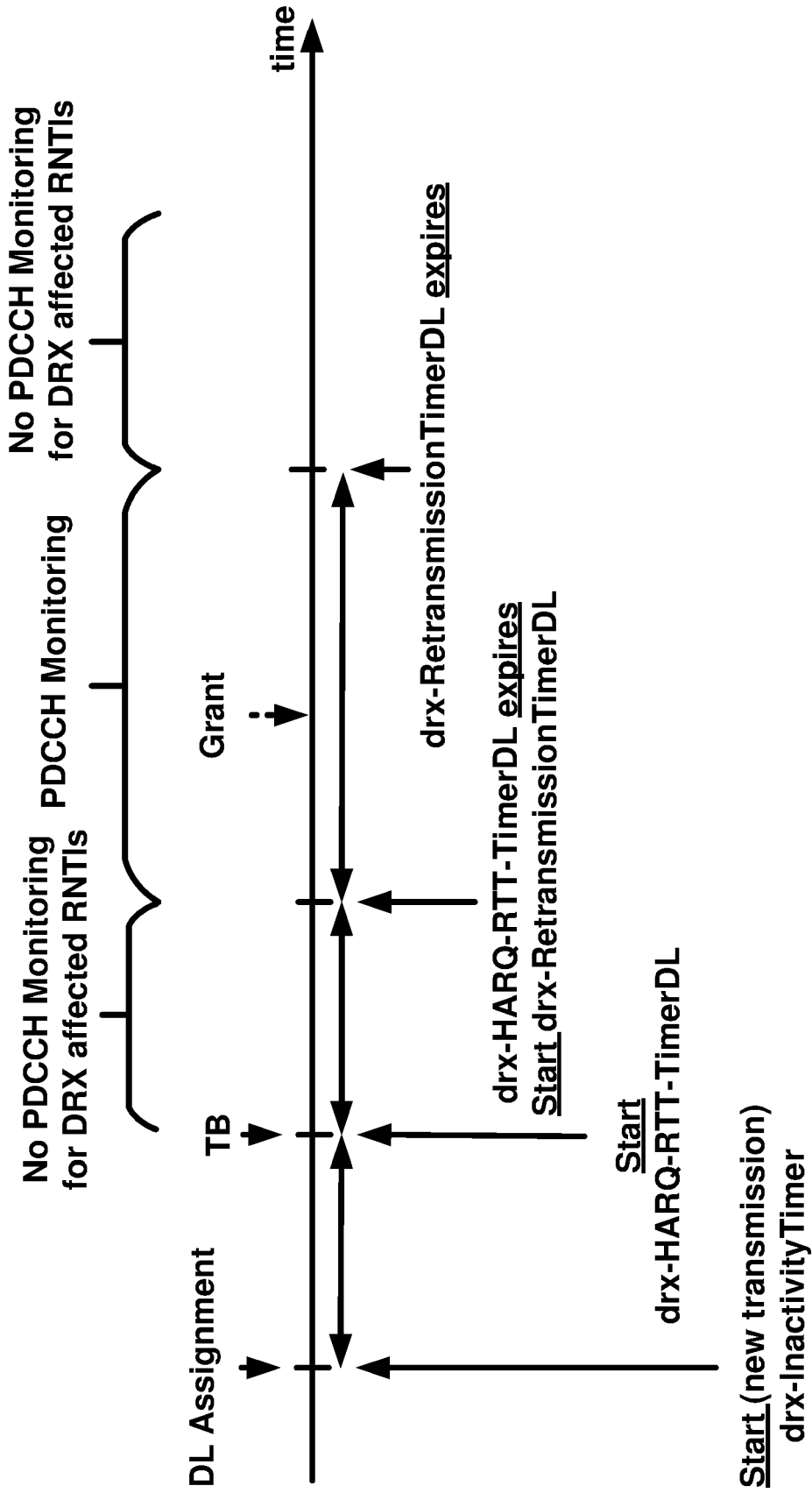

FIG. 25



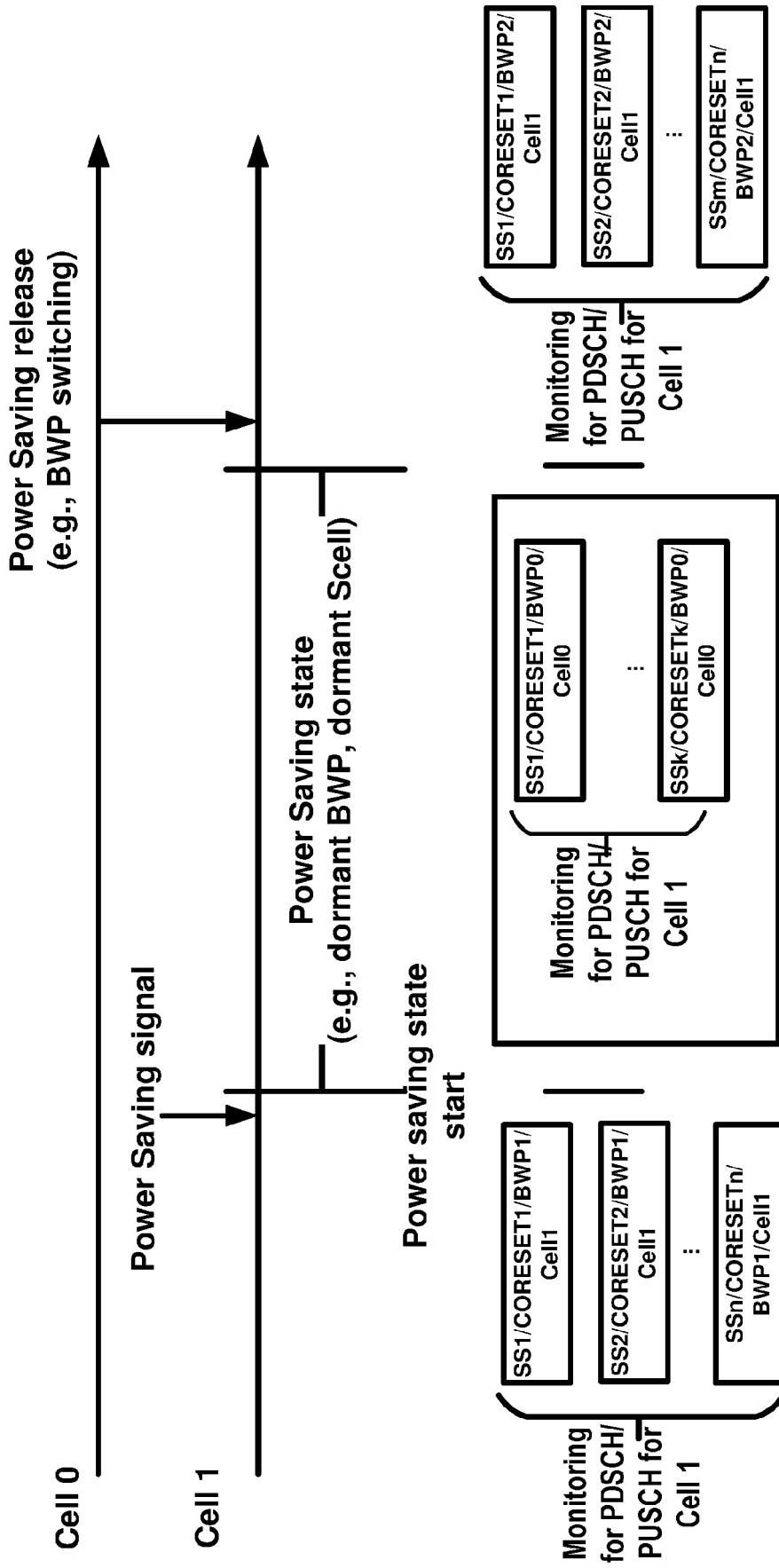

FIG. 27

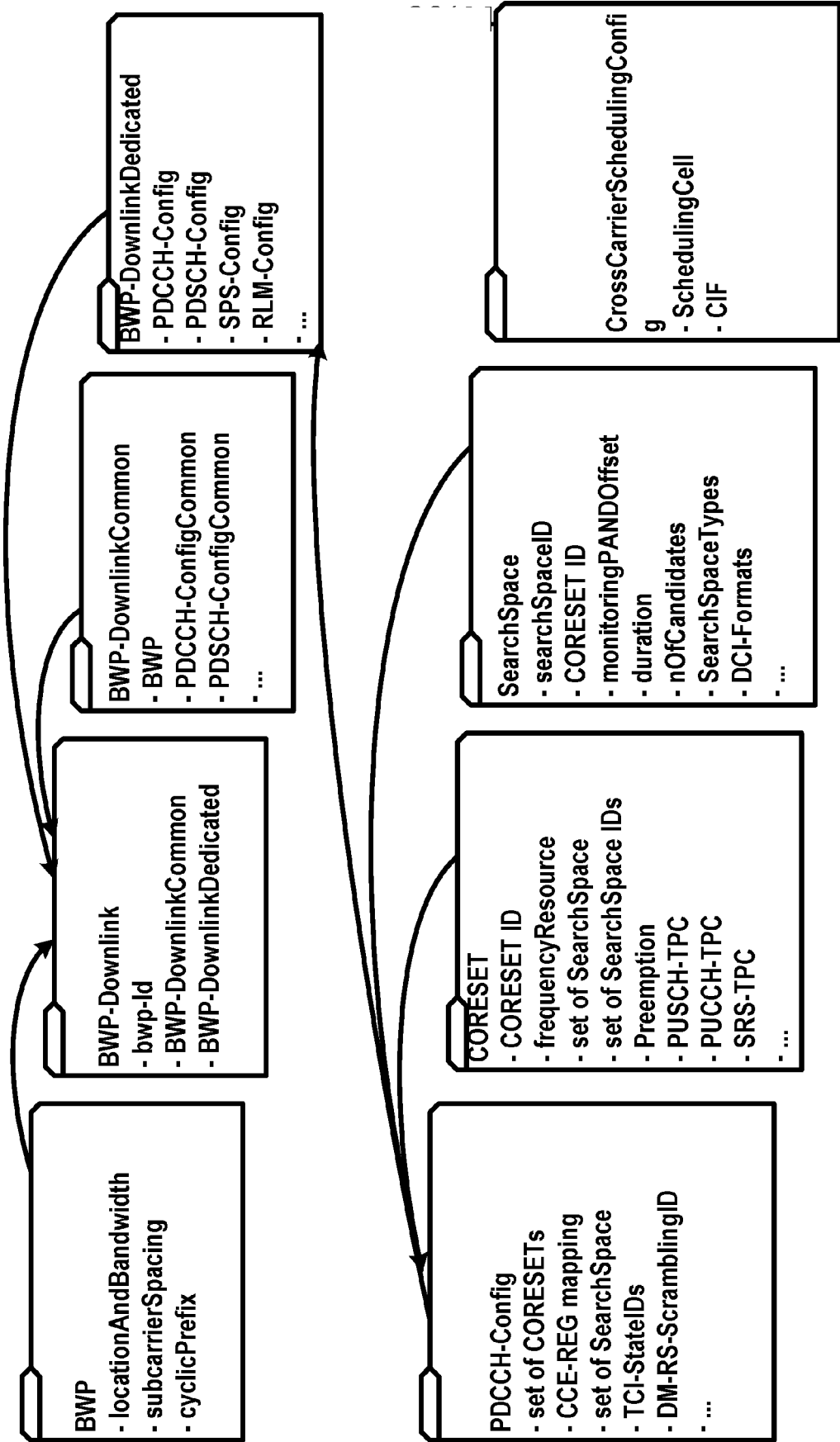

FIG. 28

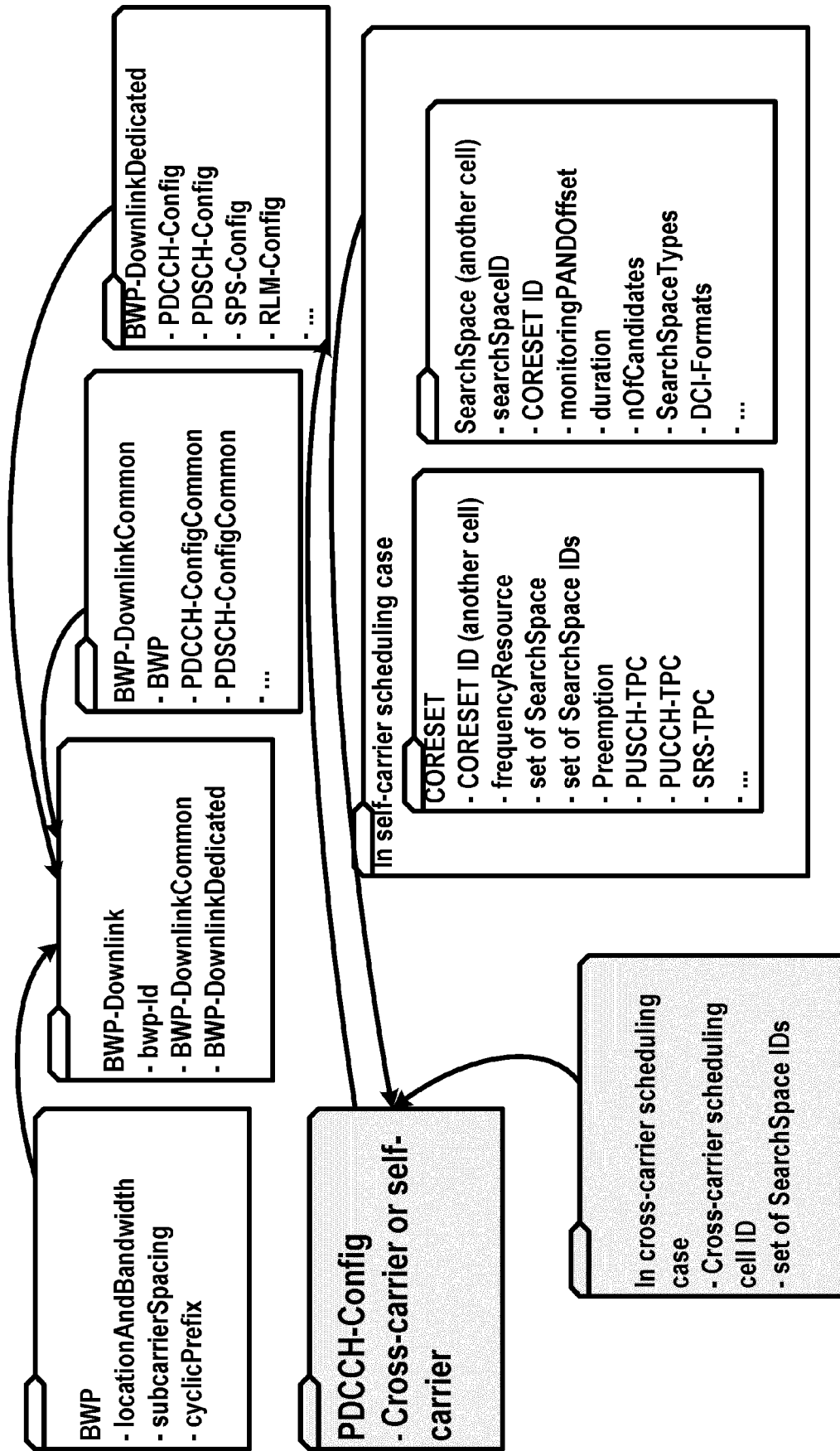

FIG. 29

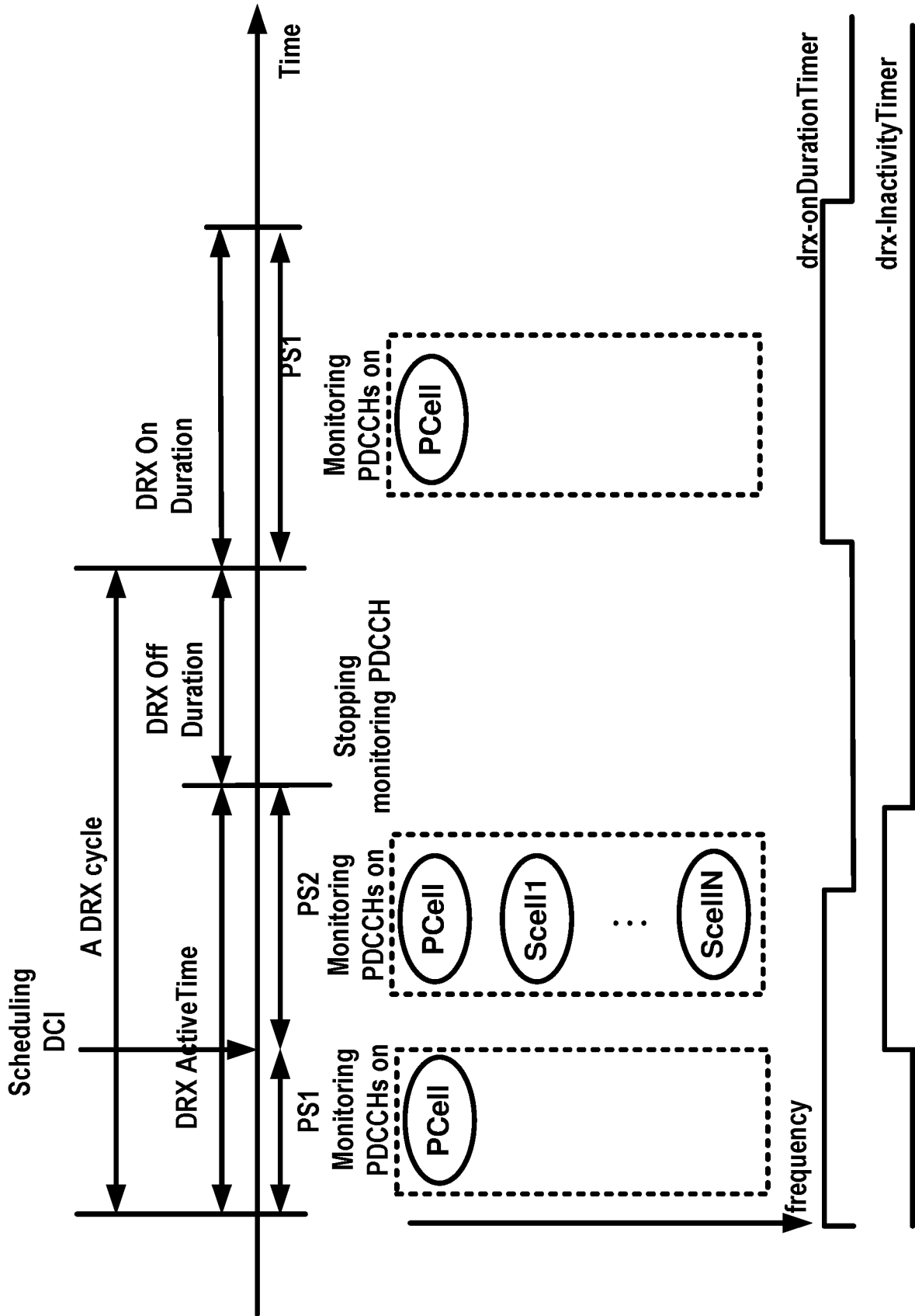

FIG. 30

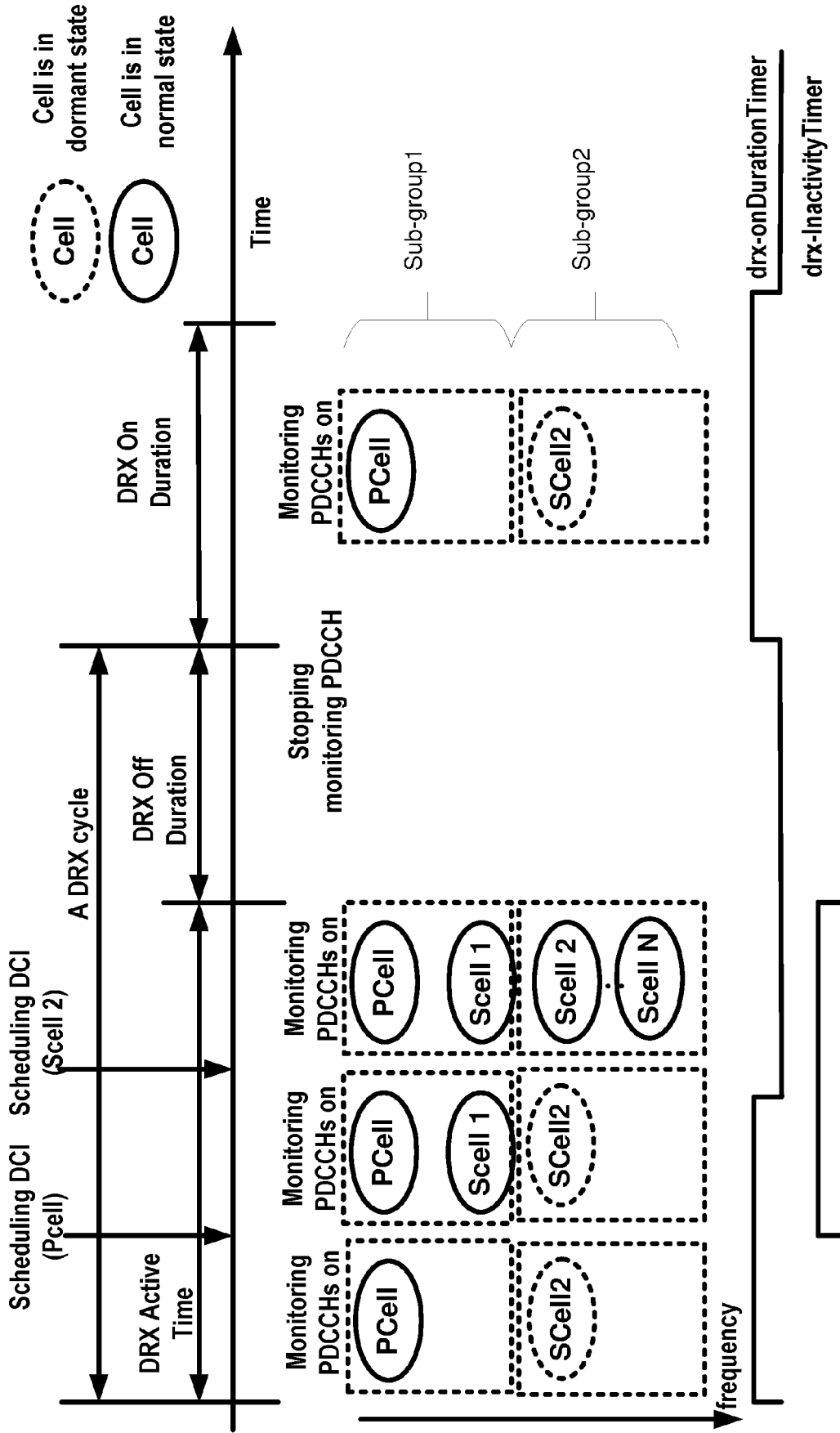

FIG. 31



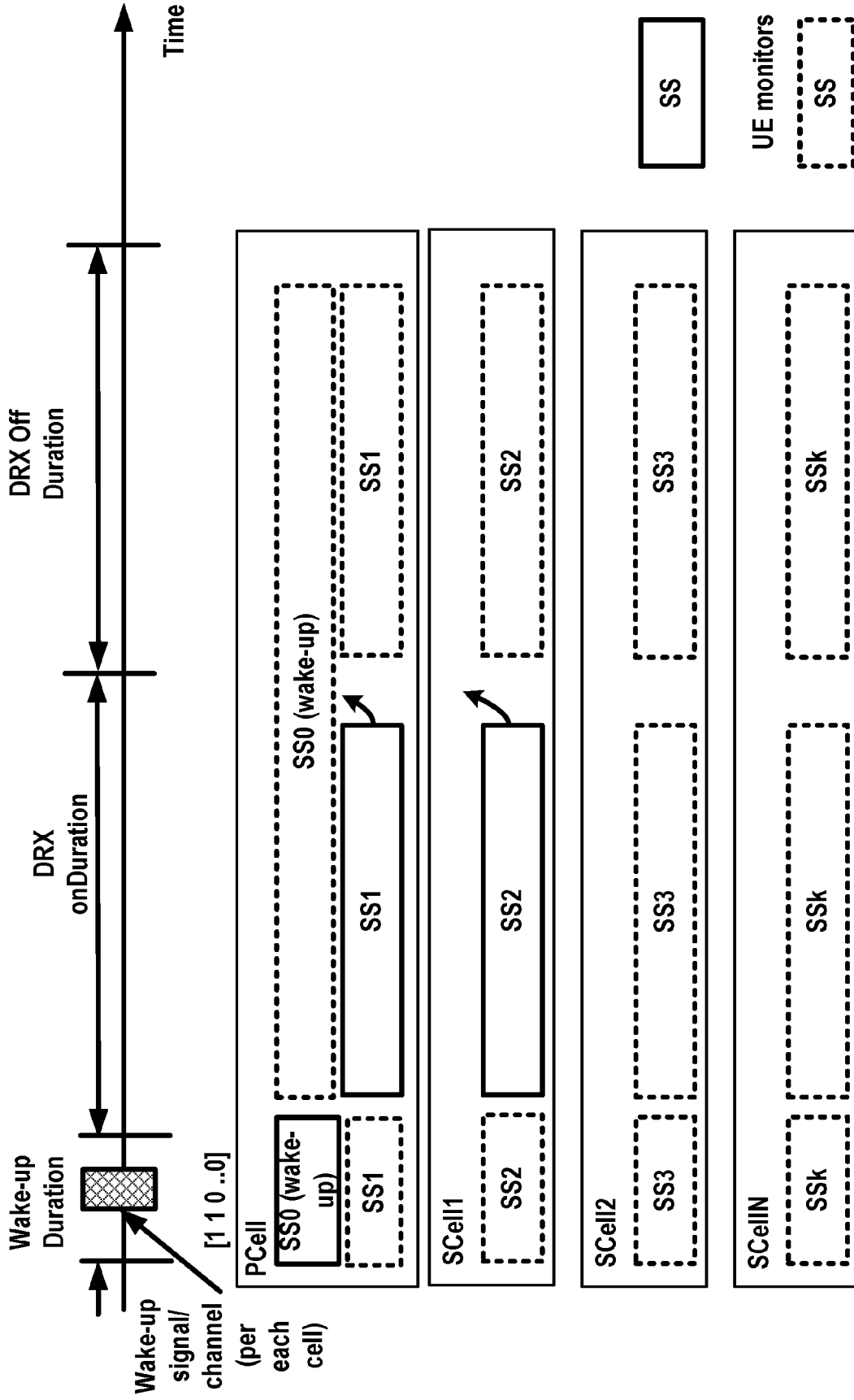

FIG. 33

UE skips monitoring

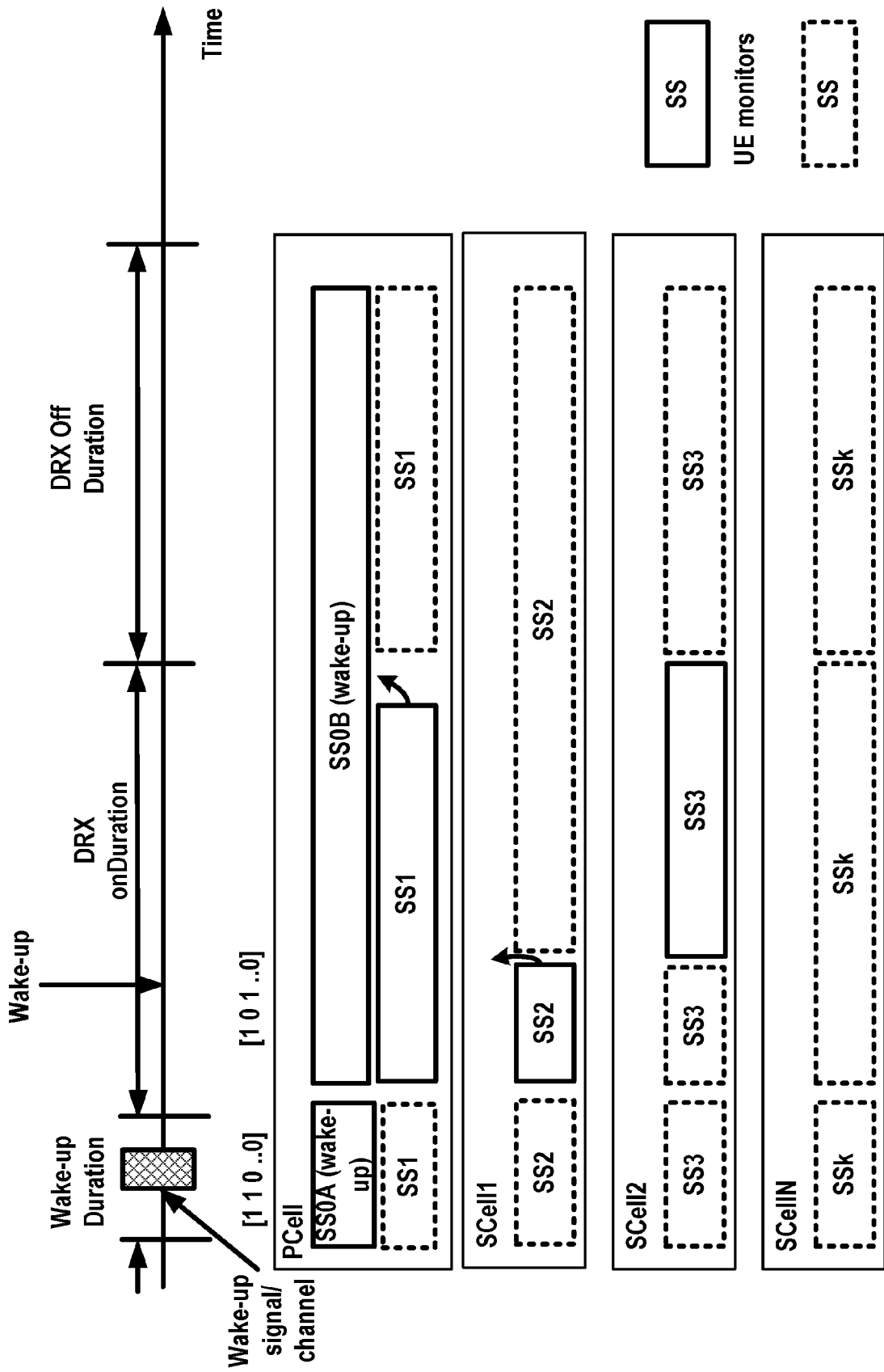

FIG. 34

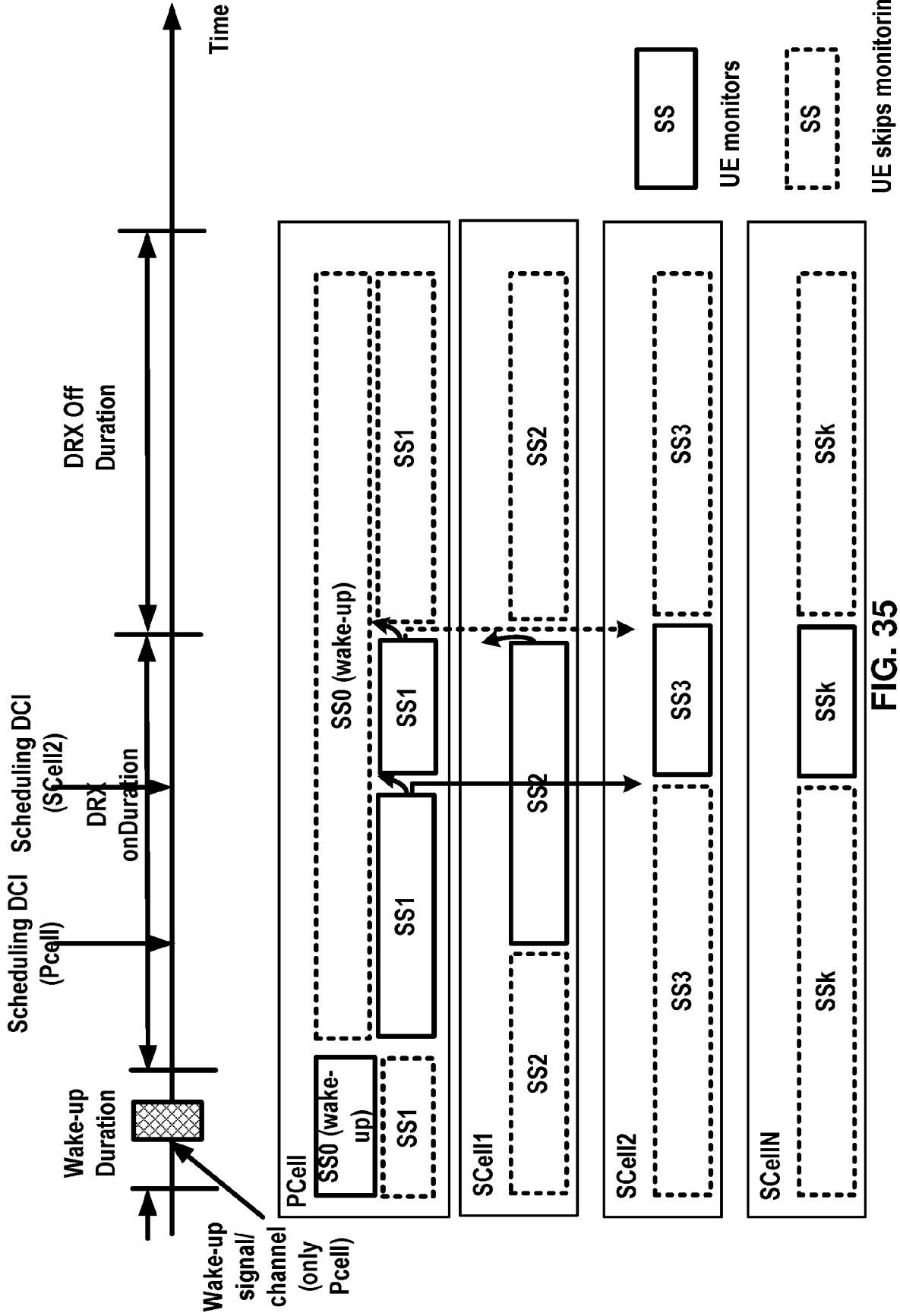

FIG. 35

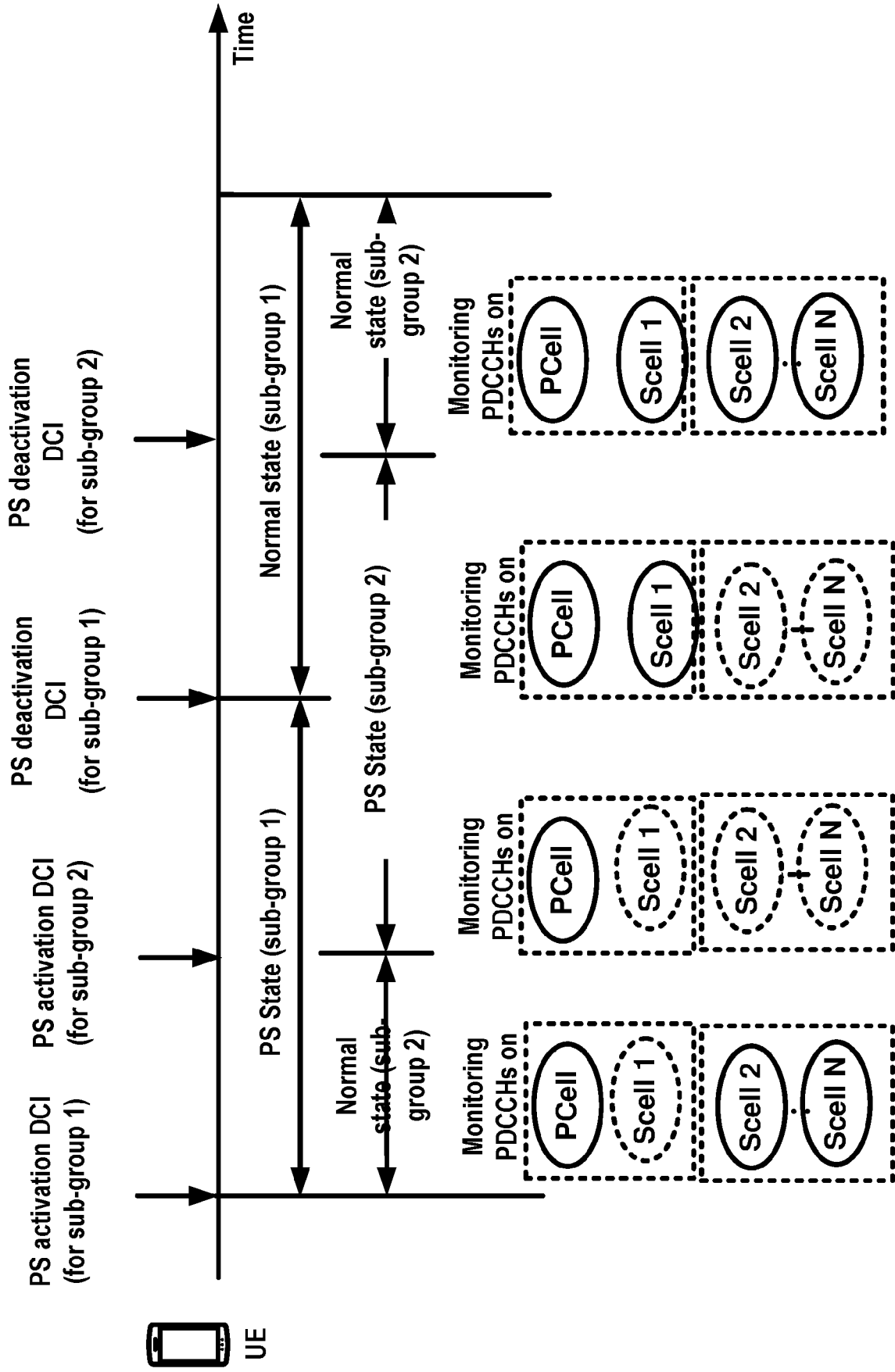

FIG. 36

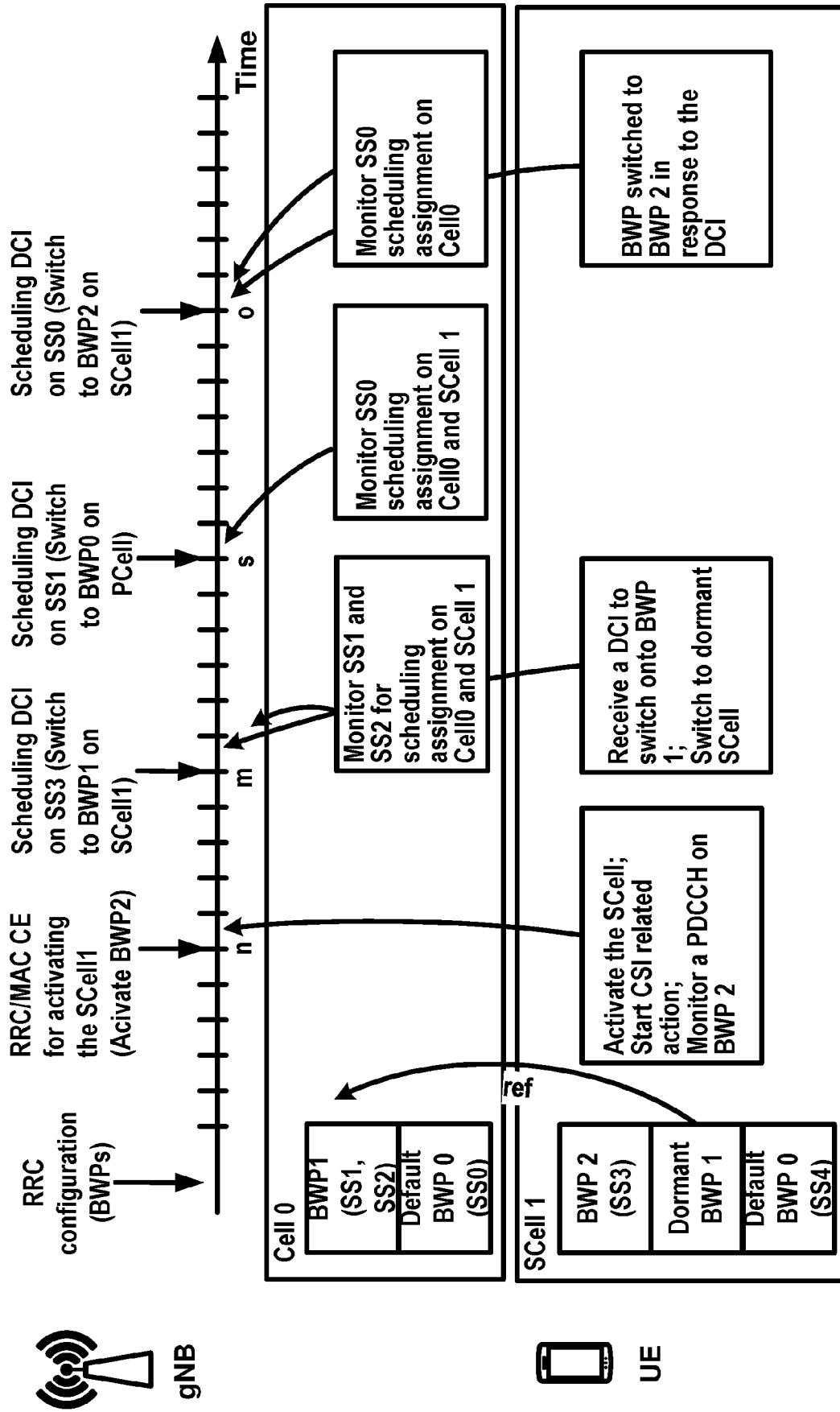

FIG. 37

Field	Size (bits)	Notes
DL/UL bit	1	
CIF	0	No CIF is assumed
UL/SUL		Follow cell 0 config
Bandwidth part indicator		follow cell 0 config
Frequency domain A		Follow cell 0 config
Time domain RA		Follow cell 0 config
MCS	5	
NDI	1	
RV	2	
HARQ	4	
DAI		Follow cell 0 config

FIG. 38

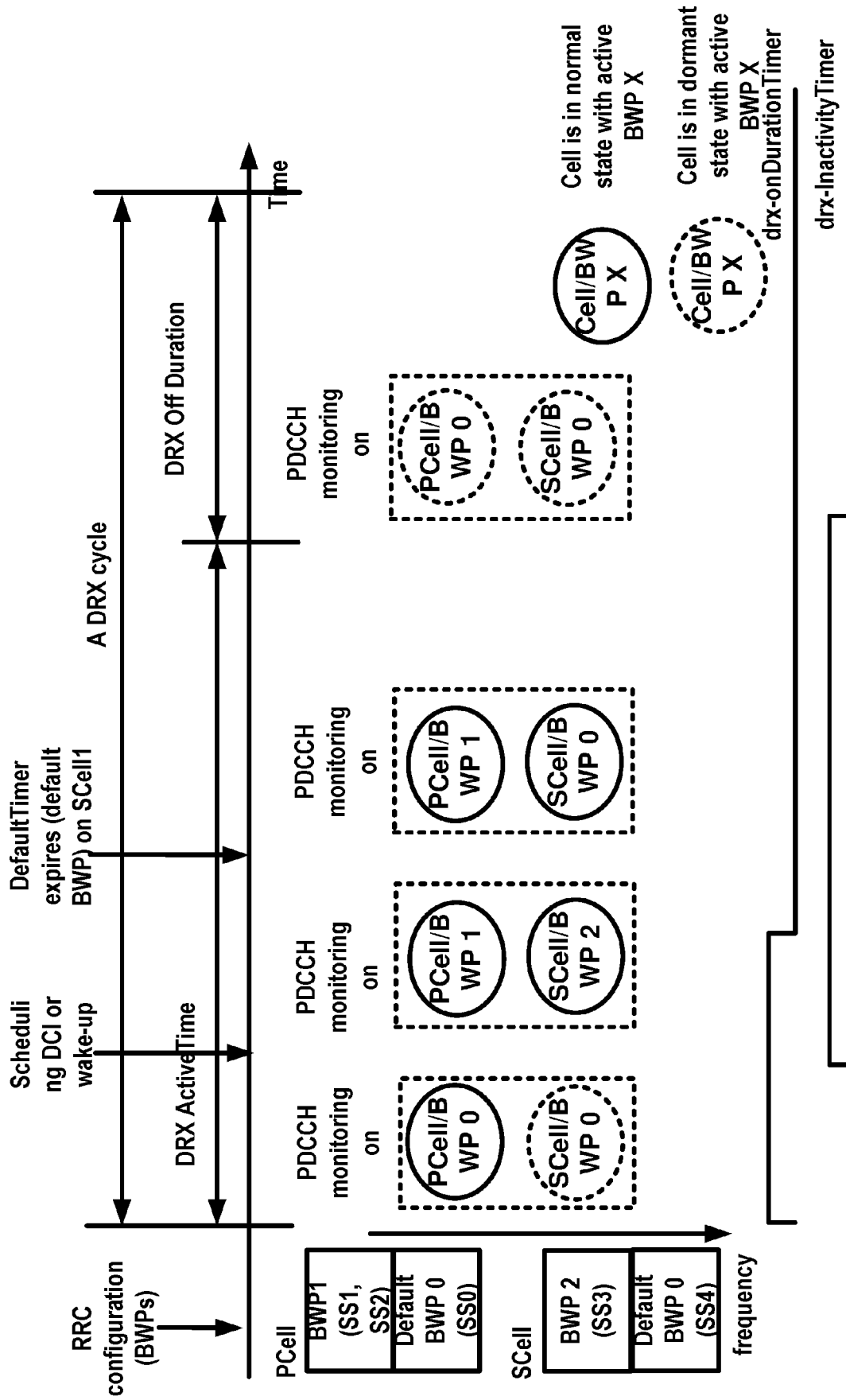

FIG. 39

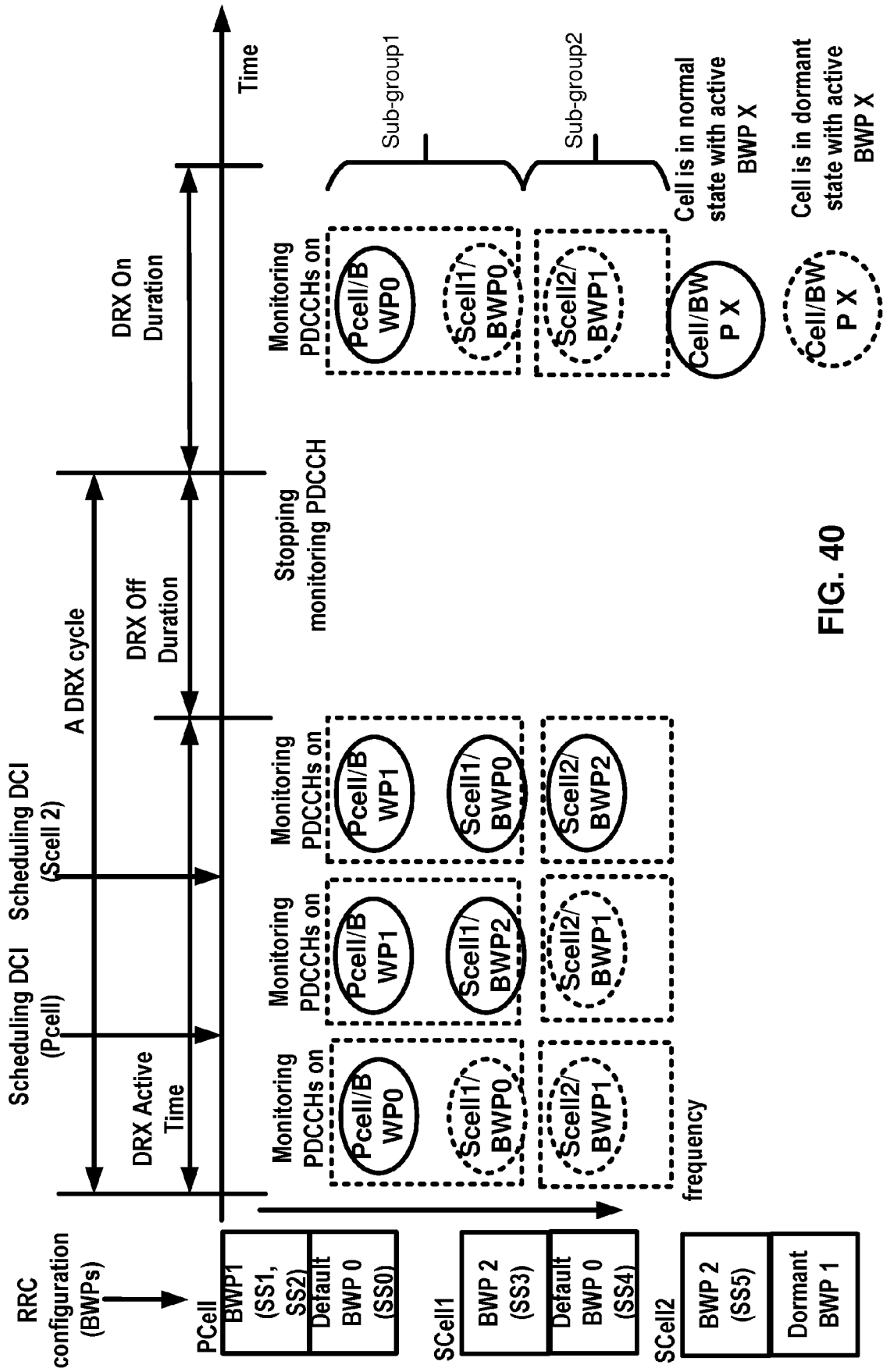

FIG. 40

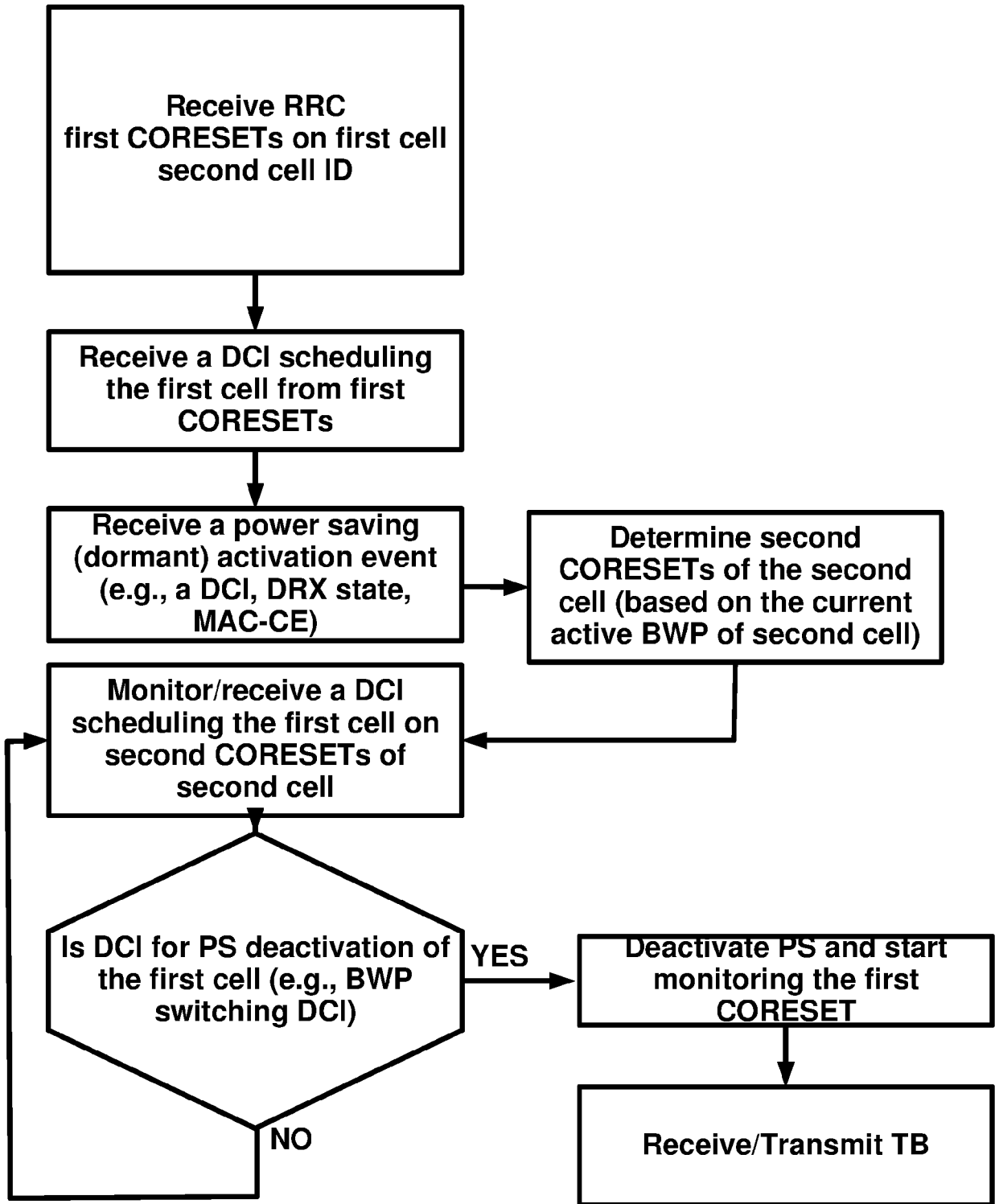

FIG. 41

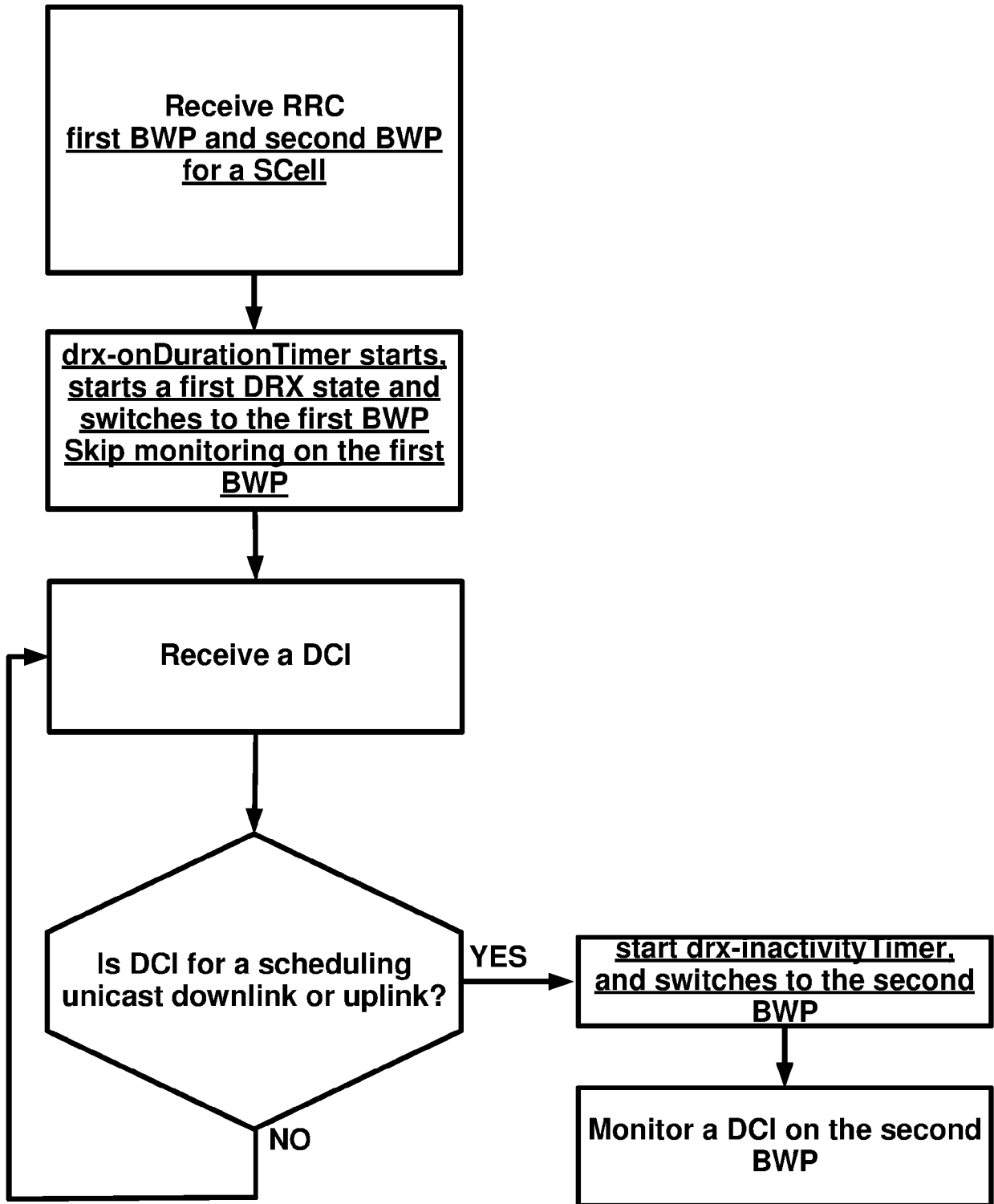
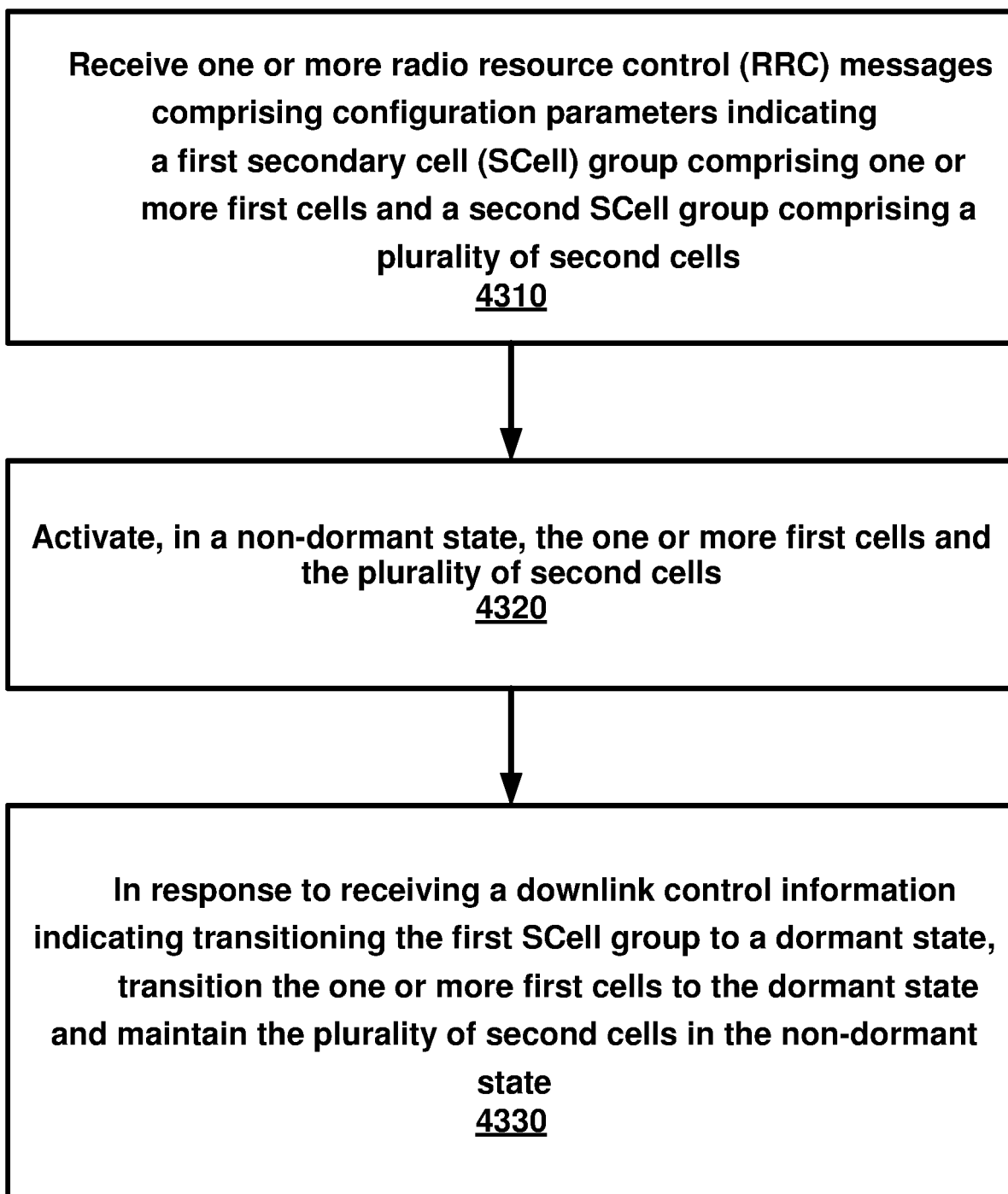
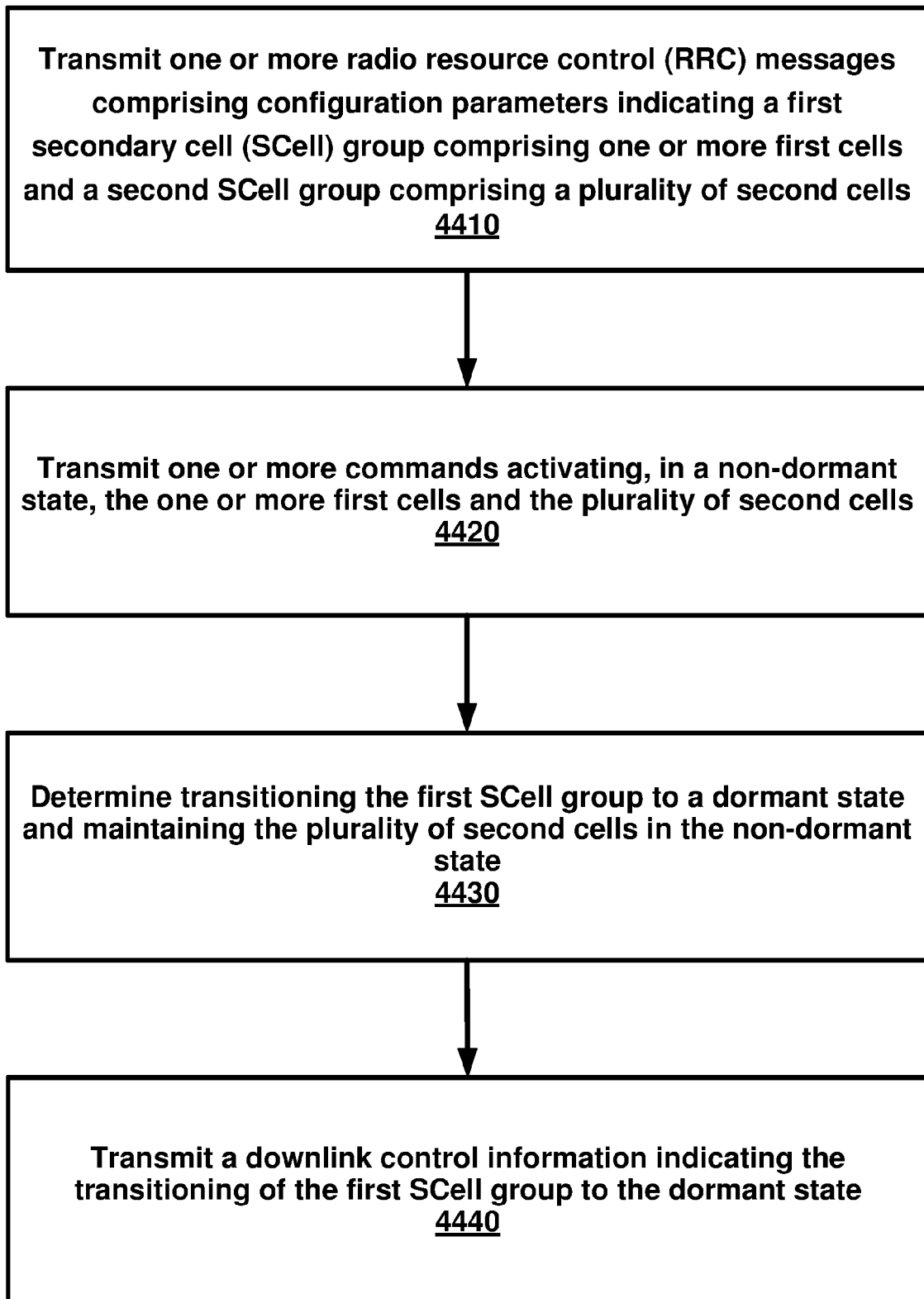

FIG. 42



**FIG. 43**



**FIG. 44**



EUROPEAN SEARCH REPORT

Application Number  
EP 20 16 6431

5

10

15

20

25

30

35

40

45

50

55

DOCUMENTS CONSIDERED TO BE RELEVANT			
Category	Citation of document with indication, where appropriate, of relevant passages	Relevant to claim	CLASSIFICATION OF THE APPLICATION (IPC)
X	<p>QUALCOMM INCORPORATED: "Open Issues on CA", 3GPP DRAFT; R1-1718581 OPEN ISSUES ON CA, 3RD GENERATION PARTNERSHIP PROJECT (3GPP), MOBILE COMPETENCE CENTRE ; 650, ROUTE DES LUCIOLES ; F-06921 SOPHIA-ANTIPOLIS CEDEX ; FRANCE , vol. RAN WG1, no. Prague, Czech Republic; 20171009 - 20171013 8 October 2017 (2017-10-08), XP051341761, Retrieved from the Internet: URL:http://www.3gpp.org/ftp/Meetings_3GPP_ SYNC/RAN1/Docs/ [retrieved on 2017-10-08] * the whole document *</p>	1-15	INV. H04W52/02
X	<p>QUALCOMM INCORPORATED: "Solutions for Fast SCG and SCell Activation", 3GPP DRAFT; R1-1903028 SOLUTIONS FOR FAST SCG AND SCELL ACTIVATION, 3RD GENERATION PARTNERSHIP PROJECT (3GPP), MOBILE COMPETENCE CENTRE ; 650, ROUTE DES LUCIOLES ; F-06921 SOPHIA-ANTIPOLIS CEDEX ; FRA , vol. RAN WG1, no. Athens, Greece; 20190225 - 20190301 16 February 2019 (2019-02-16), XP051600725, Retrieved from the Internet: URL:http://www.3gpp.org/ftp/tsg%5Fran/WG1% 5FRL1/TSGR1%5F96/Docs/R1%2D1903028%2Ezip [retrieved on 2019-02-16] * paragraph [2.2.1] *</p>	1-15	<p>TECHNICAL FIELDS SEARCHED (IPC)</p> <p>H04W</p>
-----			
-/--			
The present search report has been drawn up for all claims			
Place of search		Date of completion of the search	Examiner
Munich		4 August 2020	Volpato, Andrea
CATEGORY OF CITED DOCUMENTS		<p>T : theory or principle underlying the invention E : earlier patent document, but published on, or after the filing date D : document cited in the application L : document cited for other reasons ..... &amp; : member of the same patent family, corresponding document</p>	
<p>X : particularly relevant if taken alone Y : particularly relevant if combined with another document of the same category A : technological background O : non-written disclosure P : intermediate document</p>			

EPO FORM 1503 03.02 (P04C01)



EUROPEAN SEARCH REPORT

Application Number  
EP 20 16 6431

5

DOCUMENTS CONSIDERED TO BE RELEVANT			
Category	Citation of document with indication, where appropriate, of relevant passages	Relevant to claim	CLASSIFICATION OF THE APPLICATION (IPC)
X	<p>QUALCOMM INCORPORATED: "Potential Techniques for UE Power Saving", 3GPP DRAFT; R1-1903016 POTENTIAL TECHNIQUES FOR UE POWER SAVING, 3RD GENERATION PARTNERSHIP PROJECT (3GPP), MOBILE COMPETENCE CENTRE ; 650, ROUTE DES LUCIOLES ; F-06921 SOPHIA-ANTIPOLIS CEDEX ; FRANCE</p> <p>, vol. RAN WG1, no. Athens, Greece; 20190225 - 20190301 16 February 2019 (2019-02-16), XP051600713, Retrieved from the Internet: URL:http://www.3gpp.org/ftp/tsg%5Fran/WG1%5FRL1/TSGR1%5F96/Docs/R1%2D1903016%2Ezip [retrieved on 2019-02-16] * paragraph [3.1.1.2] - paragraph [3.1.3] *</p>	1-15	
A	<p>QUALCOMM INC: "Dormant BWP for fast SCell activation", 3GPP DRAFT; R2-1808570 DORMANT BWP FOR FAST SCELL ACTIVATION, 3RD GENERATION PARTNERSHIP PROJECT (3GPP), MOBILE COMPETENCE CENTRE ; 650, ROUTE DES LUCIOLES ; F-06921 SOPHIA-ANTIPOLIS CEDEX ; FRANCE</p> <p>, vol. RAN WG2, no. Busan, Korea; 20180521 - 20180525 20 May 2018 (2018-05-20), XP051444827, Retrieved from the Internet: URL:http://www.3gpp.org/ftp/Meetings%5F3GP P%5FSYNC/RAN2/Docs/ [retrieved on 2018-05-20] * the whole document *</p>	1-15	<p>TECHNICAL FIELDS SEARCHED (IPC)</p>
The present search report has been drawn up for all claims			
Place of search Munich		Date of completion of the search 4 August 2020	Examiner Volpato, Andrea
<p>CATEGORY OF CITED DOCUMENTS</p> <p>X : particularly relevant if taken alone Y : particularly relevant if combined with another document of the same category A : technological background O : non-written disclosure P : intermediate document</p>		<p>T : theory or principle underlying the invention E : earlier patent document, but published on, or after the filing date D : document cited in the application L : document cited for other reasons ..... &amp; : member of the same patent family, corresponding document</p>	

10

15

20

25

30

35

40

45

2  
EPO FORM 1503 03.82 (P04C01)

50

55

**REFERENCES CITED IN THE DESCRIPTION**

*This list of references cited by the applicant is for the reader's convenience only. It does not form part of the European patent document. Even though great care has been taken in compiling the references, errors or omissions cannot be excluded and the EPO disclaims all liability in this regard.*

**Patent documents cited in the description**

- US 62825293 [0001]