

⑫

EUROPEAN PATENT APPLICATION

⑰ Application number: 78300342.9

⑤ Int. Cl.²: **B 65 B 51/00**
B 65 B 49/08

⑱ Date of filing: 04.09.78

⑳ Priority: 05.09.77 JP 105784/77

㉑ Date of publication of application:
21.03.79 Bulletin 79/6

㉒ Designated contracting states:
BE DE FR GB NL SE

㉓ Applicant: **Kataoka, Hiroshi**
5-8 Asahi 1 chome
Iyo-Mishima-shi Ehime-ken(JP)

㉔ Inventor: **Kataoka, Hiroshi**
5-8 Asahi 1 chome
Iyo-Mishima-shi Ehime-ken(JP)

㉕ Representative: **Evans, David Charles et al,**
F.J. CLEVELAND & COMPANY 40-43, Chancery Lane
London, WC2 1JQ(GB)

⑤④ Device for wrapping the ends of rolls.

⑤⑦ A device for wrapping up the ends of a roll (1) in a wrapping paper (2) by winding the wrapping paper to encircle the roll in a state wherein it extends cylindrically from both ends of the roll, disposing at fixed intervals a set of tucking members (4) at either end of the roll on the outer peripheral surface of the cylindrically extending wrapping paper (2'), disposing a set of projecting members (13) at either end of the roll on the inner circumferential surface of the cylindrically extending wrapping paper, simultaneously tucking the tucking members toward the center of the ends of the roll and at the same time gradually puckering up the projecting members to form ridge portions and groove portions on the cylindrically extending wrapping paper, laying flat the ridge portions in one direction and pushing into a central hole (1') of the roll the portions of the wrapping paper which stop up the central hole.

Fig-1

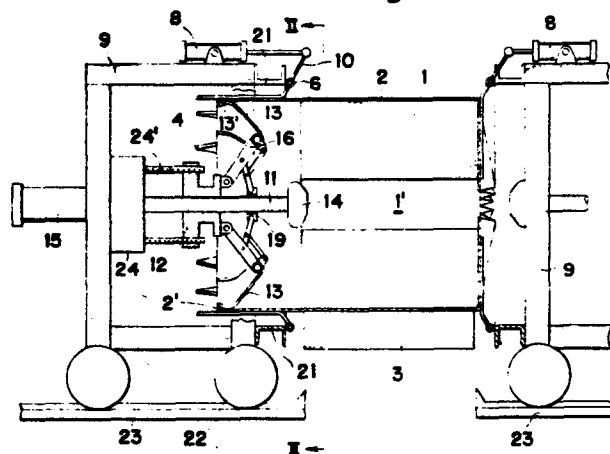

EP 0 001 171 A1

Device for wrapping the ends of rolls

This invention relates to a wrapping device and more particularly to a device for wrapping rolls to cover their ends as well as their sides.

There have hitherto been known two methods for wrapping the ends of rolls. In one method a wrapping paper is wound with its ends slightly projected from the ends of the rolls and this projected cylindrical portion of the wrapping paper is tucked gradually towards the center of the ends of the roll as the roll is rotated and a separate circular piece of wrapping paper is pasted thereon (U.S. Patent No. 2,368,213). In the other method a wrapping paper is wound with its ends projected by at least a length equal to the radius of roll, then the projected wrapping paper is twisted by rotating the roll and pushed into the hole at the center of the roll.

The former method produces a good appearance because the ends of the roll are covered with a circular piece of wrapping paper. However, it has a fault in that the process of pasting on the circular piece of wrapping paper is troublesome and that it closes up the center hole of the roll, making it inconvenient to transport.

The latter method is simpler in its process than the former. However, it may impair the quality and appearance of the roll by the formation of irregular wrinkles on the wrapped ends. Therefore, it is used

mainly for rolls of small diameter.

As methods for overcoming the defect of the latter method, the inventor previously proposed a first method
5 of wrapping about a roll a paper pre-processed to have folds in the portions destined to extend cylindrically from the ends of the roll and then winding the folded portion and tucking it into the center of the roll (Japanese Patent Disclosure No. 13984/77), and a second
10 method wherein tucking members are positioned at equal spaces on the periphery at the ends of the rolls, the cylindrical portions of wrapped paper extending from the ends of the rolls are depressed towards the center of roll so that ridge portions are formed, whereafter
15 the center portion of the wrapping paper is pushed into the center of the rolls and the ridge portions are laid in a fixed direction (Japanese Patent Disclosure No. 70691/77).

These methods proposed by the inventor have some
20 defects in that the pitch of the folds on the wrapping paper have to be changed as the diameter of the roll to be wrapped is altered, or that the projected cylindrical portion of the wrapping paper cannot always be folded evenly with the tucking members because the
25 projected portion does not always maintain a perfectly circular shape.

The invention as claimed is intended to provide a device having a set of tucking members and a set of projecting members alternately disposed respectively on
30 the outer and inner peripheral surfaces of a wrapping paper extending cylindrically from the ends of a roll, being capable of, when the tucking members are simultaneously moved toward the center of the ends of the roll, causing the projecting members to be pucked up
35 while forming ridge portions of the wrapping paper between the tucking members and being capable of causing

the projecting members to escape from the inner surface of the wrapping paper immediately before the tucking members come into contact with the ends of the roll.

5 After the ridge portions of the wrapping paper formed between the tucking members brought into intimate contact with the ends of the roll are laid flat in one direction, the portions of the wrapping paper which stop up a
10 hole.

Since the cylindrically extending wrapping paper is tucked on the ends of the roll in a state wherein the inner and outer peripheral surfaces thereof are strainedly supported, the device according to the
15 present invention can wrap the ends of the roll neatly by producing even folds and prevent the central hole of the roll from being stopped up. Accordingly, the present device is suitable particularly for a roll of large diameter.

20 Some ways of carrying out the invention are described in detail below with reference to drawings, in which:-

Figure 1 is a front view, partially in cross section, of the device for wrapping the ends of rolls
25 according to this invention.

Figure 2 is a sectional view of the device in Figure 1.

Figures 3(A) - 3(D) are the illustrations of the device according to this invention showing the state of
30 the wrapping paper as it is tucked in the ends of the rolls.

Figure 4 illustrates the state of the wrapping paper tucked in the ends of the rolls.

Figure 5 is the enlarged front view showing another
35 example of tucking members of the device for wrapping the ends of rolls according to this invention.

Figure 6 is a plan view of the tucking members shown in Figure 5.

Figure 7 is a side view of the tucking members shown in Figure 5.

Figure 8 is an explanatory view showing the state of tucking when the tucking members in Figure 5 are used.

Figure 9 is an explanatory view showing another example of the device for wrapping the ends of rolls by this invention.

Figure 1 shows one embodiment of the device for wrapping the ends of rolls according to this invention.

At first, a roll 1 to be wrapped is rotated by rollers 3, (rotation and support mechanisms not shown) to have several wrappings of a wrapping paper 2 wound thereon so as to project from the ends of the roll 1. Consequently, the end portion 2' of the wrapping paper projects cylindrically from both ends of the roll 1. The length of the projected wrapping paper 2' should be slightly larger than the radius of the roll.

At either end of the roll 1, there is provided a device for wrapping that end of the roll. As the devices are identical only one of them will be described.

The device is mounted on a frame 9 and is adjusted to a prescribed distance from the end of the roll by moving the frame 9 supported by wheels 22 along a rail 23.

A cylindrical frame 21 having a slightly larger diameter than that of the roll to be wrapped is provided on the frame 9. The cylindrical frame 21 has a number of tucking members 4 for tucking in the projected portion of the wrapping paper 2' placed at equal intervals about the circumference thereof. A fulcrum supporting shaft 6 for each tucking member 4 is supported by a bearing 5 fixed on the side of the cylindrical frame 21. The fulcrum supporting shafts 6 of the tucking members are



connected by flexible joints 7 in a generally circular pattern. (Figure 2)

5 An arm 10 is projected from the fulcrum supporting shaft of the topmost fulcrum supporting shaft 6, and a fluid pressure cylinder 8 is connected to the arm 10. Therefore, the operation of the fluid pressure cylinder 8 causes the tips of the tucking members 4 to turn simultaneously towards the center of the cylindrical frame
10 around the fulcrum supporting shaft 6.

At the position corresponding to the center hole of the roll 1, a plug 14 having substantially the same diameter as that of the hole 1' projects from the frame 9, and the plug 14 is given an axial movement and slow
15 rotational motion through a shaft 11. The shaft 11 of the plug 14 has a sliding base 12 and a fixed ring 19 fitted thereon. The sliding base 12 has pivotally attached thereto a number of radially extending main arms 16 equal to the number of tucking members 4.

20 The tip of each main arm 16 is provided with a rotary piece 17 having welded thereon a projecting member 13 and the main arm 16, the rotary piece 17, an arm 18 and an arm 20 form a parallelogram. The lower end of the arm 20 is pivotally attached to the fixed
25 ring 19. Therefore, when the sliding base 12 is caused to advance on the shaft 11 by rotation of driving screws 24', the link mechanism of the projecting members 13 all expand radially at one time and the tips 13' of the projecting members are placed between the
30 tucking members 4. Then if the sliding base 12 is caused to retract by reverse rotation of the driving screws 24', the main arm 16 and the projecting members 13 are brought more parallel to the shaft 11, that is they are brought into a folded state. The driving screw
35 24' is rotated by a motor (not shown) in a box 24.

In the device for unspooling the ends of rolls, the



Frame 1 is moved so as to position the fulcrum supporting shafts 6 of tucking members 4 near the end of the roll 1 which has been wound on its periphery with wrapping paper 2 by the roller 3 (Figure 2(A)).

When the fulcrum supporting shafts 6 are positioned near the end of the roll 1, the cylinder 8 is operated to turn all the tucking members 4 inward at one time and the sliding base 12 is advanced to cause the projecting members 13 to rise and bring the tips 13' into contact with the inside of the cylinder of wrapping paper 2' projecting from the end of the roll 1.

Therefore, the tucking members contact periphery of the cylinder of wrapping paper 2' projecting from the end of the roll 1 from the outside to produce groove portions, while the projecting members contact the cylinder of wrapping paper from the inside at points lying between the tucking members to produce ridge portions. (Figure 3(B))

Once the cylinder of wrapping paper 2' has been contacted from both the outside and inside, the tucking members are caused to turn inward by further operation of the cylinder 8. Then, the sliding base 12 is caused to draw back so as toucker up the projecting members. The operation of the projecting members is slightly delayed so that the cylinder of wrapping paper is always forced into grooves by the tucking members and into ridges by the projecting members.

Just before, the tucking members contact the end of the roll (Figure 3(C)), a cylinder 15 for drawing back the shaft 11 together with the sliding base 12 is put into operation and the projecting members 13 and the plug 14 are withdrawn from the cylinder of wrapping paper 2' (Figure 3(D)). Therefore, only the tucking members 4 remain in pressing contact with the end of the roll and the ridges are maintained in the wrapping paper (see the

right end of Figure 1). The roll 1 is then rotated slightly so that the tucking members fold over the ridges and cause them to lie flat in one direction.

5 Then the cylinder 15 is operated to cause the part of the folded wrapping paper which faces the hole 1' to be pushed into the hole by the plug 14 and thus complete the wrapping of the roll. The tucking members can be of rod or plate shape and can be made of plastic, wood or
10 metal. They are of a length equal to or somewhat less than the thickness of the paper on the roll (from the surface to the center hole). When the structure shown on Figure 5 - Figure 7 is used, the folds will be finished more neatly on the ends of the roll.

15 Referring to Figures 5 to 7, projecting rails 26 are provided on the both sides of a bar member 25 having a fin, and triangular plates 27 are slidably inserted into the projecting rails 26. For controlling the sliding motion of the triangular plates 27, a cylinder
20 29 is fixed on the bar member 25 and connected with triangular plates 27 through a bracket 28.

At the top of the bar member 25, an elastic wire 30 is supported by the shaft and rotated by the cylinder 31 placed at the tip of the bar member 25.

25 In case of using tucking members as mentioned above, a lever 32 is rotated by a cylinder 31 about a shaft 33 and a supporting shaft 6 is rotated by a cylinder (not shown) after the tip of the wire 30 contacts with the end of the roll 1. At the same time,
30 the projecting members 13 in contact with the inside of the cylinder of wrapping paper 2' are puckered up gradually by drawing back the sliding base 12. Thus, at the end of the cylinder of wrapping paper, ridge and groove portions are formed as shown on Figure 8(A).

35 When the tucking members are further turned and the projecting members 13 are withdrawn from the wrapping

paper, the tucking members remain in close contact with the end of the roll with the ridge portions maintained as shown on Figure 8(B). At this time, the wire 30 is
5 drawn into a groove provided at the bottom of the bar member 25. Appropriate gaps are left between the tucking members 14 in close contact with end of the roll. Therefore, when the cylinder 29 is operated, the triangular plates 27 on both sides of the bar member 25 are
10 caused to slide towards the center along the projecting rail 26 to eliminate the gaps between triangular plates 27 and raise the ridges (Figure 8(C)). In such state, the roll 1 is rotated and the ridges are laid towards the periphery. Therefore, the end of the wrapping paper
15 is pushed into the hole 1' by the plug 14.

Further, a flexible piece 34 is provided on the tip of the tucking members 4 as shown in Figure 9. This piece 34 is normally held in extended state by means of a spring 35, and when the wrapping paper is pushed
20 in by the plug 14, it is caused to bend into the hollow hole under the force of the plug 14. Through this action the piece 34 protects the edge of the hole and also makes the folds neat.

The projecting members 13 is made of a highly
25 flexible wire material because the wrapping paper may be broken if the motions of the tucking members 14 and the projecting members 13 are not smoothly coordinated. The material of these pieces can be metal, plastic, wood, bamboo, etc.

30 In case of an actual operation, the most appropriate relationship between the motions of the tucking and projecting members can be obtained by experiments and calculations, and it is preferable to control the hydraulic cylinder-actuating motor so that the tucking and
35 projecting members can work in accordance with such relationship.



The device for wrapping the ends of rolls according to this invention, as explained above, folds the cylinder wrapping paper projecting from the ends of the roll by supporting the cylinder from both the inside and the outside and thus is able to wrap the ends in neat folds. It is especially suitable for wrapping rolls having a larger diameter.

Claim:

1. A device for wrapping up the ends of a roll (1)
in a wrapping paper (2) which has been wrapped to
5 encircle the roll and which being longer than the roll
extends cylindrically from both ends thereof by simul-
taneously moving toward the center of the ends of the
roll a set of tucking members (4) at either end of the
roll which members are disposed at given intervals on
10 the outer peripheral surface of the wrapping paper (2')
extending cylindrically from the ends of the roll and
by pushing into a central hole (1') of the roll the
portions of the wrapping paper which stop up the central
hole, characterized in
15 that a set of projecting members (13) at either end of
the roll are further disposed on the inner peripheral
surface of the cylindrically protruding wrapping paper
at positions falling between the tucking members,
simultaneously puckered up in proportion as the tucking
20 members are moved toward the center of the ends of the
roll and caused to escape from the inner surface of the
cylindrically protruding wrapping paper before the
tucking members come into contact with the ends of the
roll.
- 25 2. The device according to Claim 1, wherein said
tucking members are formed in the shape of a triangle
and come into radial contact with the ends of said
roll.
- 30 3. The device according to Claim 2, wherein each of
said tucking members is provided with a pair of wings
capable of moving toward the center of the ends of
said roll after said tucking members come into contact
with the ends of said roll.



Fig-1

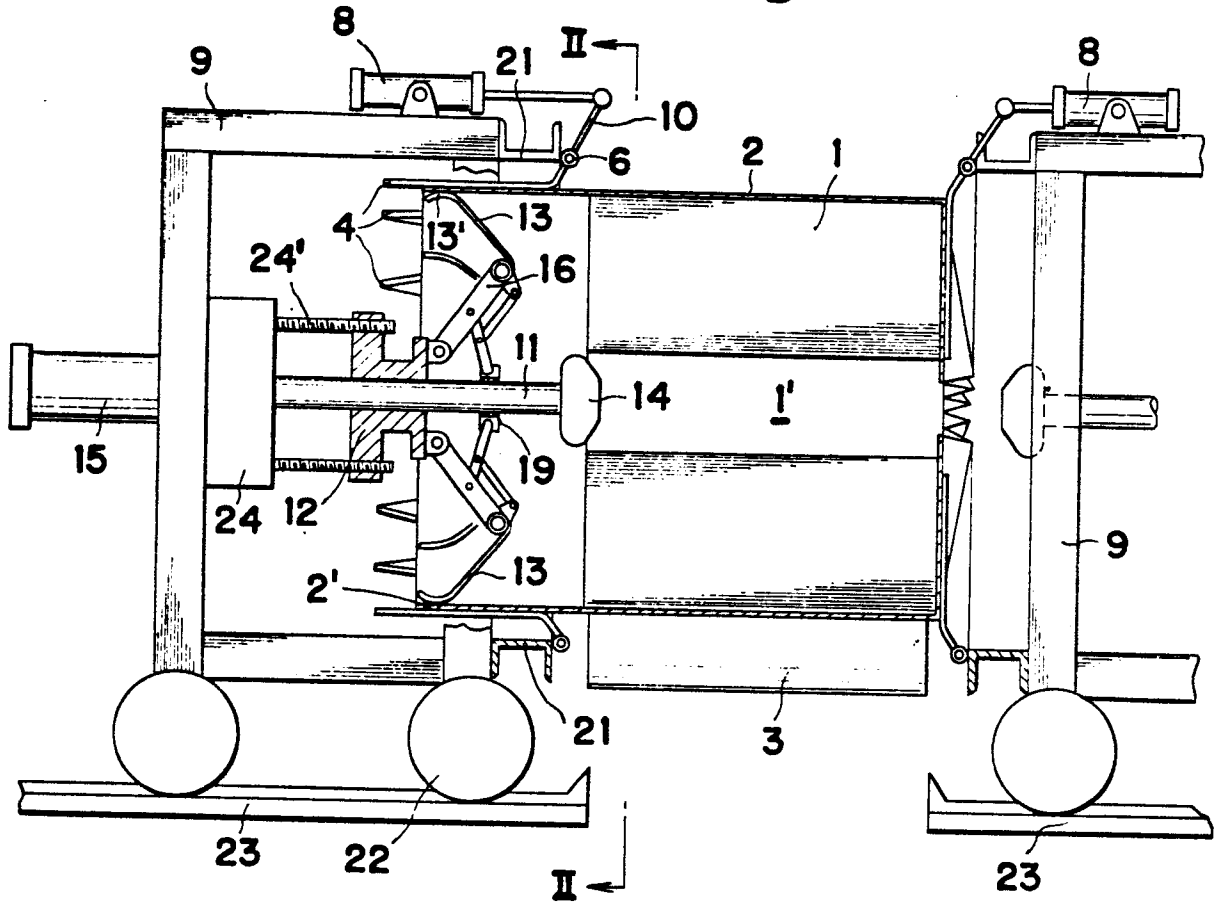

Fig-2

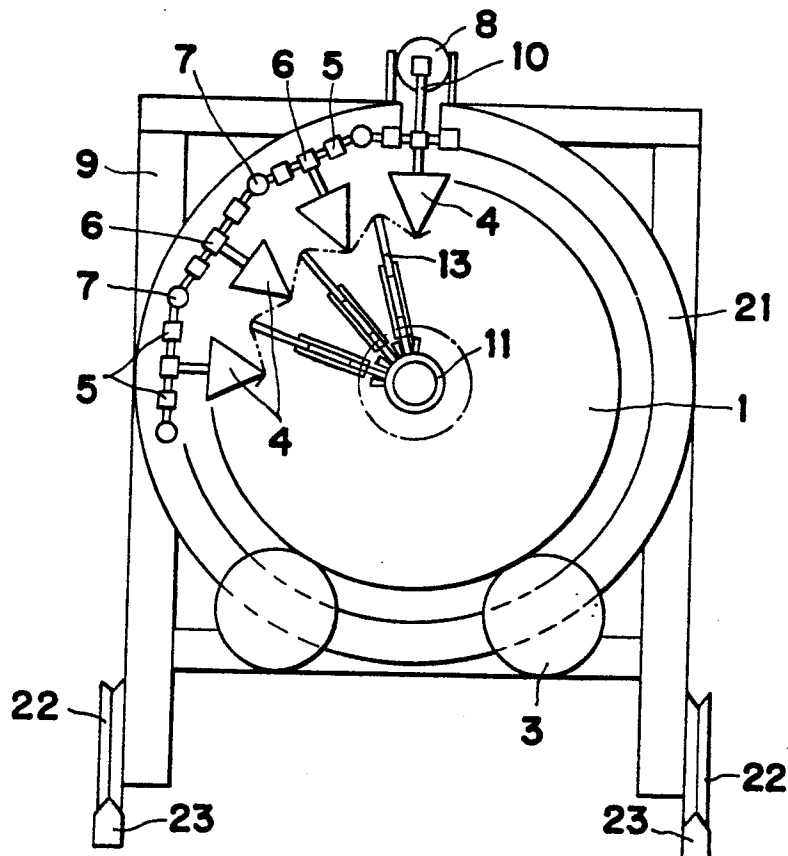

Fig-3(A)

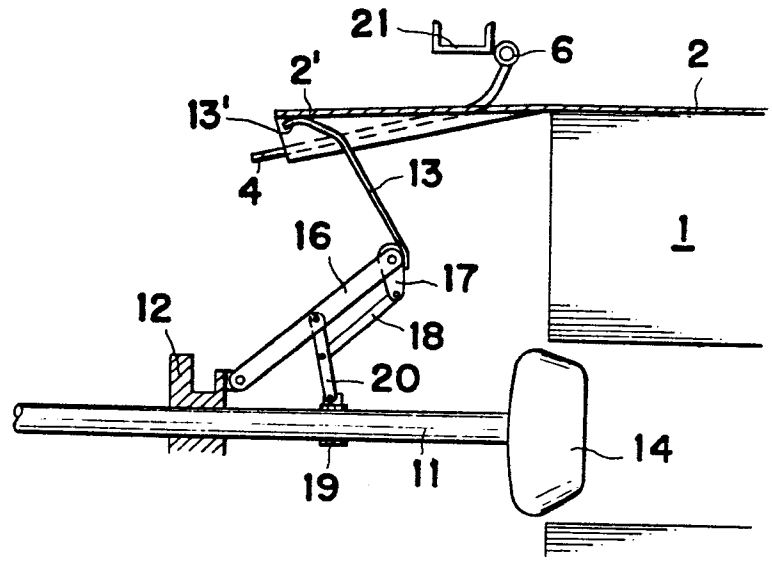

Fig-3(B)

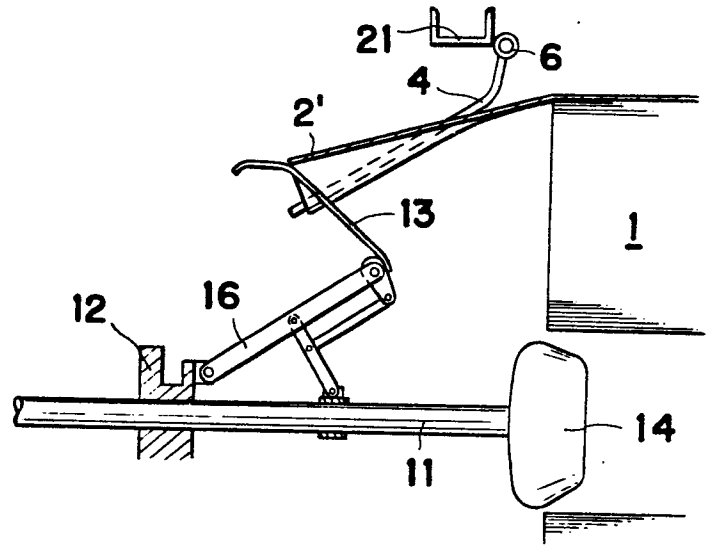

Fig-3(C)

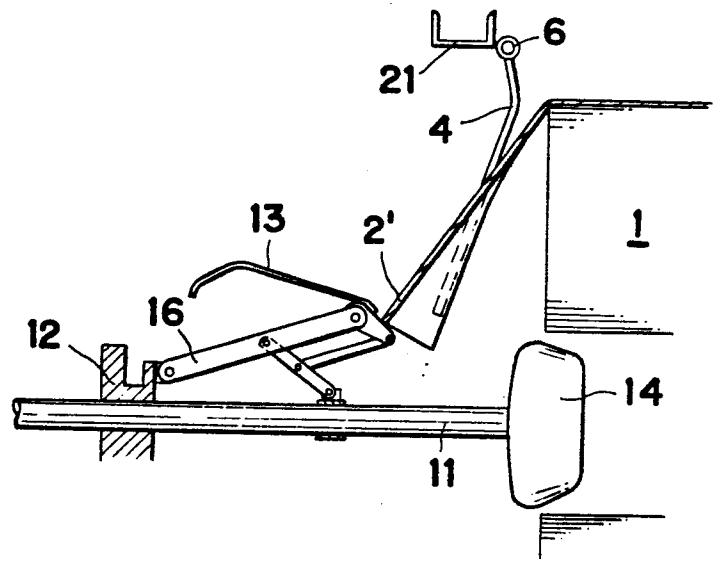

Fig-3(D)

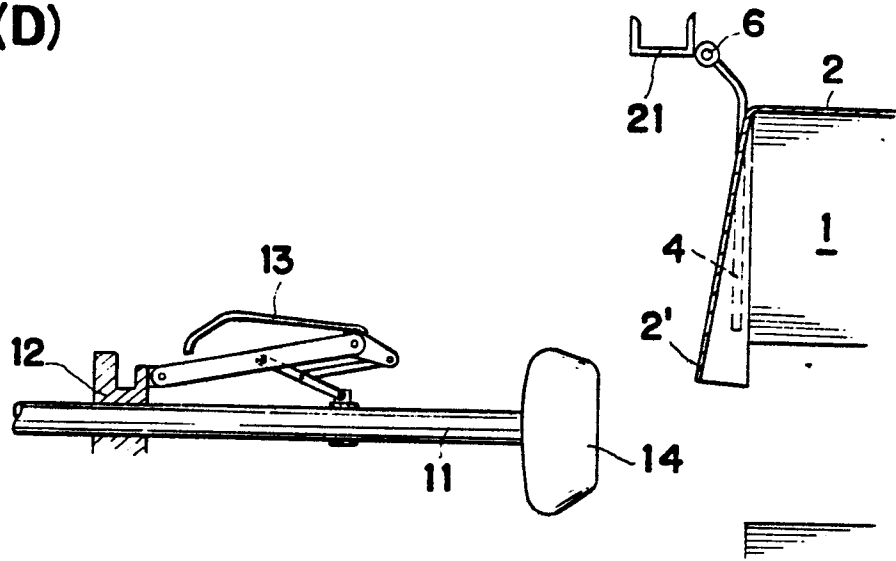

Fig-4

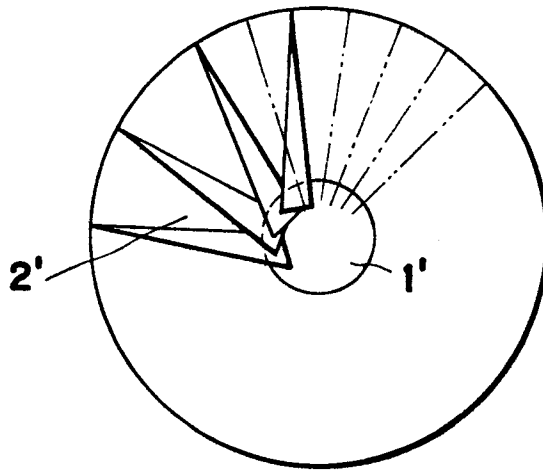

Fig-6

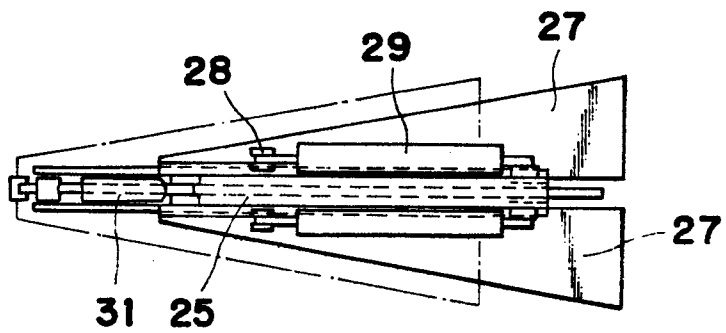

Fig-8(A)

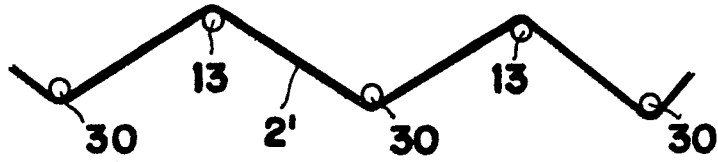

Fig-8(B)

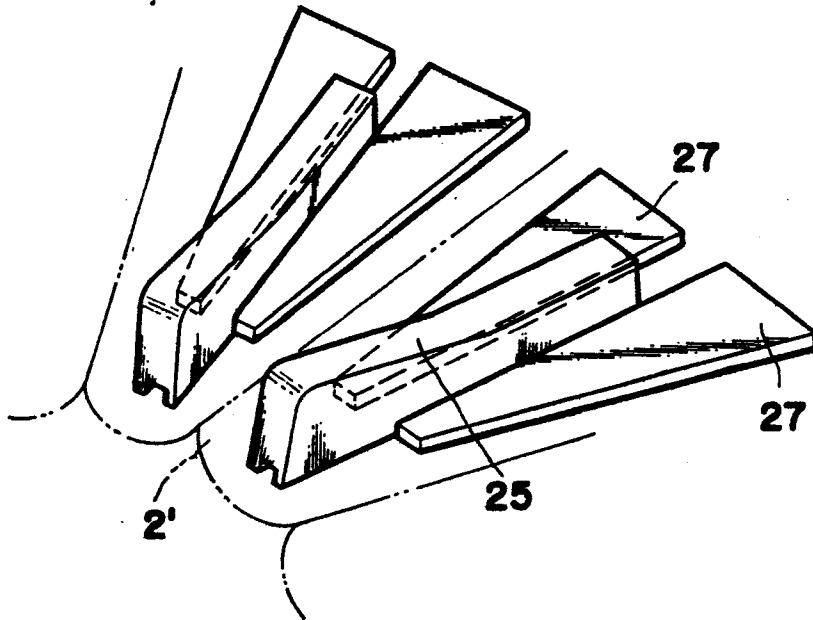
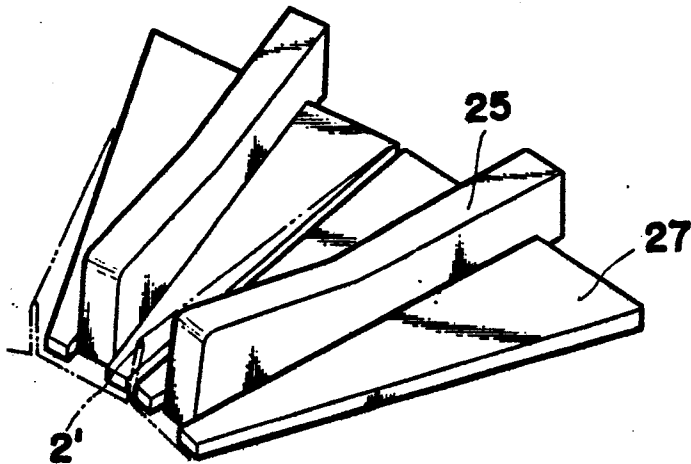

Fig-8(C)





DOCUMENTS CONSIDERED TO BE RELEVANT			CLASSIFICATION OF THE APPLICATION (Int. Cl. ²)
Category	Citation of document with indication, where appropriate, of relevant passages	Relevant to claim	
X	<u>US - A - 2 066 414 (MILMOE)</u> * Page 4, column 2, line 61 to page 5, column 2, line 59; figures 12-20 * ---	1	B 65 B 51/00 B 65 B 49/08
	<u>US - A - 2 110 814 (PARSONS)</u> * Page 2, column 2, line 16 to page 3, column 2, line 17; figures 7-13 * ---	2	
A	<u>US - A - 2 363 751 (SCHULTZ)</u> * Page 7, column 1, line 55 to page 10, column 1, line 53; figures 45-50 * -----	1	TECHNICAL FIELDS SEARCHED (Int.Cl. ²) B 65 B
			CATEGORY OF CITED DOCUMENTS X: particularly relevant A: technological background O: non-written disclosure P: intermediate document T: theory or principle underlying the invention E: conflicting application D: document cited in the application L: citation for other reasons
The present search report has been drawn up for all claims			&: member of the same patent family, corresponding document
Place of search The Hague	Date of completion of the search 01-12-1978	Examiner CLAEYS	