

⑫ **NEW EUROPEAN PATENT SPECIFICATION**

⑬ Date of publication of the new patent specification: **23.09.87**

⑭ Int. Cl.⁴: **B 03 D 1/14 // B03B5/58, C02F1/40**

⑮ Application number: **78100947.7**

⑯ Date of filing: **21.09.78**

⑰ **Flotation plant and process for fibre recovery and liquid clarification, particularly for paper mill effluents.**

⑱ Priority: **26.09.77 IT 8363577**

⑲ Proprietor: **FARINONE, Pierino**
c/o UFFICIO BREVETTI VARESI
Viale belforte 89
21100 Varese (IT)

⑳ Date of publication of application: **18.04.79 Bulletin 79/08**

㉑ Inventor: **FARINONE, Pierino**
c/o UFFICIO BREVETTI VARESI
Viale belforte 89
21100 Varese (IT)

㉒ Publication of the grant of the patent: **23.09.87 Bulletin 87/39**

㉓ Mention of the opposition decision: **17.03.82 Bulletin 82/11**

㉔ Representative: **Racheli, Adele, Ing.**
Via San Michele del Carso, 4
I-20144 Mailand (IT)

㉕ Designated Contracting States: **DE FR**

㉖ References cited:
DE-A- 288 462
FR-A- 651 286
FR-A-2 296 464
IT-A- 704 314
US-A-2 888 139
US-A-3 452 869
US-A-4 022 696

EP 0 001 418 B2

Description

The invention relates to flotation plants and to a process for fibre recovery and liquid clarification. Particularly the invention relates to flotation plants for fibre recovery comprising a circular vessel containing liquid mixture to be treated, characterized by the fact that it comprises a radially extending dam which is rotatable in the vessel to cause a pressure on the front side of the dam and a depression on the back side of the dam, thus locally raising the liquid level adjacent the dam said rise substantially corresponding to the thickness of the fibre layer, and lifting floating fibres to a collection zone. Preferably, the rotating dam is followed — with reference to the rotation direction of the dam itself — by a radial pipe provided with spouts arranged along its lower wall, by a trough forming a radial channel having an inclined base, and finally by a projection preferably forming a single unit with the dam, the arrangement being such as to cause liquid mixture fed through the spouts to follow a serpentine path in counter-current to the direction of rotation of the dam.

The invention relates also to a process for fibre recovering. A known plant of the aforesaid kind is disclosed e.g. in Italian Patent No. 704,314, filed 7th September, 1963, by Milos *Krofta*: "Process and device for depurating non-clarified water waste particularly from paper and cellulose mills.

In such known plant the collection of fibres, which is caused to float, is provided for by rotatable equipment comprising substantially a radial arm provided with a scoop extending radially and formed in cross-section as an Archimedean spiral. Such scoop is rotatable around its axis and is caused to operate in the floating fibre layer. Of course, the operation of such scoop, subjected to both rotation around the axis of the flotation tank and a movement of rotation around its own axis, is not even. In fact, during each turn of 360° only a rotation of scoop of about 120° is effective to collect the floating fibre. The arrangement is such that if the effective angle is increased the scoop dips deeply into and also collects the clarified liquid, whereas if the effective angle is reduced fibre collection is poor (the expression "effective angle" means the angle during which the scoop really collects the fibres to be collected). Such scoop, of course, raises the collected fibre which is caused to drop inwardly for disposal.

US-Patent n. 3,452,869 discloses a movable dividing wall which slowly rotates in a vessel while fluid is removed and entered from this moving wall so as the positive pressure which would normally be on the forward face of the wall is reduced by the expedient removal of the fluid adjacent the aforesaid forward face. At the same instant, the otherwise negative pressure areas on the trailing side of the barrier is neutralized by the addition of new unclassified materials.

In this way no substantial rise takes place, because this is prevented by the flow distribution

which modifies the pressures in front and behind the movable dividing wall.

US-Patent n. 4,022,696 also discloses a set of walls slowly rotating in the tank, one of which, placed radially with respect to the tank. In both these US patents the collection of the sludge is made by means of a rotating scoop, that is identical to the one provided in a mechanical way with a radial archimedean screw, forming a spiral scoop which cyclically sinks into the fluid and lifts up fibres.

This mechanical collection has the following disadvantages:

1) fibre removal only along a radial portion which is about a third of the whole radial distance between the inner and outer surface of the tank.

If this portion is increased, the scoop must sink more deeply removing water together with the fibres and jeopardizing the plant efficiency;

2) discontinuous removal also in time; the archimedean screw while rotating sinks and lifts into the water;

3) the elevated turbulence due to the immersion and raising of the scoop.

Such incomplete collection of floating fibre involves a long processing time and partial liquid clarification.

An object of the invention is to obviate the above mentioned disadvantages.

With this object in view the present invention provides a plant and a process as defined by the appended claims where a hydraulic removal substitutes the known mechanical removal of fibres.

Specifically the invention provides a flotation plant for fibre recovery comprising a circular vessel having an axis, containing liquid mixture to be treated and comprising in said vessel a dividing wall placed radially which is rotated about said axis, characterized in that this dividing wall is formed as an overflow dam, the upper edge of which is connected to a trough, so that the pressure caused on the front side of the dam locally raises the level of the liquid mixture thus lifting above the upper edge the layer (4) of floating fibres which then reach the trough.

The invention will be described further, by way of example, with reference to the accompanying drawings, in which:—

Figure 1 is a diametrical vertical cross-section view of a plant according to the present invention.

Figure 2 is a plan view of the plant of Figure 1.

Figure 3 illustrates a cross-section view, made along the line III—III of Figure 2.

Figure 4 is a detail of Figure 1 on an enlarged scale.

Referring now to the drawing, a plant for recovering fibre from effluents known as black liquors (e.g. from pulpmills) comprises substantially circular effluent vessel 1 having a lip 10. Within vessel 1 is provided a central circular coaxial space which contains control means for driving the rotating fibre pick-up unit 3, as well as a system for collecting fibers, a system for feeding the effluent to an annular bath and a system for collecting the clarified water. The pick-up unit

3 comprises one or more tubes 30 for collecting the clarified water and a radial effluent feed pipe 31. For driving the pick-up unit 3 the arrangement is as follows: to a power source r , s , t , are connected lines r' , s' , t' , which lead to a current collector 32 which is connected with a motor 34. From motor 34 extends the driving end 35 of a motor shaft on which gears 36 and 37 are provided. Gear 36 drives a chain 36', which, in turn, drives a gear 36'' fastened to the collecting rotor of the fiber pick-up unit (to be described hereafter). Gear 37 drives a chain 37' which, in turn, drives a gear 37'' fastened to a shaft 137 extending radially from unit 3. Shaft 137 is connected, with its end opposed to the end connected to gear 37'', to a shaft 137' also extending radially in the vessel, by means of reversing gear device 237. Preferably, the shafts 137' are more than one e.g. three. Fastened to the outer end of each shaft 137 and 137' there is a wheel 337 which engages the lip 10 of vessel 1 and provides for rotation of unit 3. From an axial vertical feed pipe 38 the feed is delivered to the radial pipe 31 through rotatable coupling 32'.

At the bottom of vessel 1 there is a radial pit 5, for collecting precipitated sludge, the collection being improved by rotating a doctor 50. Such sludge flows outwardly e.g. through a tube 51.

In known systems the liquid surface is level and a spiral scoop skims an upper layer collecting and raising the floating fibres. The operation of such known spiral scoops is cyclic i.e. the collection of fibres is perfect only in one point during each revolution of spiral scoop. Elsewhere the collection of fibres is either poor or a quantity of water is collected together with fibres. According to the present invention, at the surface of the bath 11 a rise h is created. Suitably such rise h is as high as the thickness of fibre layer 4 so that said fibres 4 may be collected by gravity at a lower level i.e. in central space 21. Sealing is obtained by providing unit 3 with walls 60 which cooperate with resilient sealing members 61. Provision of rise h is brought about by a dam 7 which extends over the whole height of the bath 11. Vessel 1 is filled in, in such a way so as the surface 6 of the liquid mixture in the vessel is substantially equal to the upper edge 70 of the dam 7. Close thereafter, considering the direction of rotation of unit 3 which is, with reference to figure 2 clockwise, there is a radial pipe 31 parallel to the upper edge 70. The upper edge of radial pipe 31 is coplanar with edge 70. Thereafter, considering the direction of rotation of unit 3, there is a trough 71 which too extends radially and is provided with bottom wall sloping down towards the central space 21. One of its outer walls extends upwardly to provide an apron 72. From the base 73 of dam 7 extending in a direction contrary to the rotation direction of same, there is a bottom wall 74 with a projection 75 which provides, in cooperation with the trough 71, a serpentine path 76 for the feed flow. In fact radial pipe 31 is provided with outlet spouts 31' extending downwardly, consequently the feed passing therethrough follows the path 76 indi-

cated by the arrows. As it can be seen from Figure 3 the feed flow follows thereafter a horizontal path contrary to the direction of rotation of unit 3. The fraction of feed which passes over the dam 7 is controlled by controlling the rotation speed of same. The volume of this fraction is equal to the volume of the inlet feed following path 76 less the volume of the outlet flow discharging through tubes 30. More particularly, the volume of this fraction is kept constantly equal to the volume of fibers collected at trough 71. Consequently, the inlet and outlet volumes are in balance and the driving energy of the barrier brings about a "wave" a rise h and containing the fibre layer 4 arranged in front of fibre collecting trough 71.

According to a preferred embodiment of the present invention, to provide an easy collection of fibers, which when picked-up according to this invention, are rather compact and sticky, a collecting rotor 8 is provided which is driven by chain 36'. As such collecting rotor is a member of unit 3 in operation it is subjected to a rotation about the vessel axis 100 and about its own axis. Collecting rotor 8 comprises a tube 80 having a plurality of spokes 81, e.g. six. On each spoke 81 is adjustably mounted a blade 82. The arrangement is such that the distance between the blade and rotor axis may be adjusted so as to regulate the effect of each blade in operation. For adjusting the process variables two ways are available:

- 1) controlling the speed of revolution of pick-up unit 3 and correspondingly the inlet and outlet flow of the liquids involved;
- 2) adjusting the blades 82 and particularly the rim level of dam 7 relative to the liquid surface 6. Of course, the rotor 8 with its blades 82 improves the collection of fibers urging them into trough 71 to be ducted to the central space 21. From central space 21 they can be removed through tube 83.

As described previously, the outlet of clarified liquid take place through outlet holes 30', provided in tubes 30. The liquid flowing therethrough reaches an annular space 2 thereof which is hydraulically sealed off both from the central space 21 and from the bath 11. In fact, the inner and outer walls 2 and 21 of the annular space 2, are arranged at the bottom with a sealing coupling 60—61 of the kind shown at Figure 4.

Operation of plant is as follows: initially vessel 1 is empty and the pick-up unit is stationary. The liquid to be treated is fed through feed pipe 38. It flows through radial pipe 31 and spouts 31'. As soon as the liquid in the bath 11 has reached a level quite close to upper edge 70 of the dam 7, the pick-up units are started and valves (not shown) are opened to provide a path for the clarified water from the bottom layers of the bath 11 to reach the annular space 2 and to leave the plant through lines 91 and 92. By the combined effect of feed effluent liquid, and removing clarified liquid as well as by rotation of dam 7, a dynamic balance is established which brings about a rise h of the layer of fibres before the rotor 8 and a counter-current movement of the inlet flow following path 76. The arrangement is such

that when unit 3 and the rotor 8 revolve, the rotor blades urge the fibres into trough 71 through which they reach the central space 21 to be ducted outwardly through tube 83. On the vessel bottom precipitates the heaviest matter which provides a sludge which is collected by doctor 50 and urged into pit 5. For the necessary adjustments it is advisable to control the inlet and outlet flows instead of adjusting mechanical members which are difficult to regulate.

Claims

1. A flotation plant for fibre recovery comprising a circular vessel (1) having an axis (100), containing liquid mixture to be treated and comprising in said vessel (1) a dividing wall placed radially which is rotated about said axis (100), characterized in that this dividing wall is formed as an overflow dam (7), the upper edge (70) of which is connected to a trough (71), so that the pressure caused on the front side of the dam locally raises the level of the liquid mixture thus lifting above the upper edge (70) the layer (4) of floating fibres which then reach the trough (71).

2. A flotation plant for fibre recovery according to claim 1, characterized by this that the rotating dam (7) is followed — with reference to the rotation direction of the dam itself — by a radial pipe (31) provided with spouts (31') by a trough (71) forming a radial channel having an inclined base and finally by a projection (75) preferably forming a single unit with the dam (7), the arrangement being such as to cause liquid mixture fed through the spouts (31') to follow a serpentine path (76) in counter-current to the direction of rotation of the dam.

3. A flotation plant for fibre recovery according to claims 1 and 2, characterized by a radially extending and possibly adjustable bladed collecting rotor (8) which is mounted substantially vertically over the dam (7) and rotates with the dam, the rotor (8) also rotating about a horizontal axis in such a way as to plunge its blade (82) into the fibres layer (4) so as to transport the fibres to the collection zone.

4. A flotation plant for fibre recovery according to claim 3, characterized by the fact that the radial rotor (8) rotates about said horizontal axis in a direction contrary with respect to the dam revolution direction.

5. A flotation plant for fibre recovery according to claims 1 and 2, characterized by this that the spouts (31') of the radial pipe (31) are downwardly oriented in order to create a flow having a vertical downward course, and/or that the fibres, after leaving the collection zone, follow a downward run.

6. A flotation plant for fibre recovery according to the previous claims, comprising at least four concentric zones separated one from the other by movable dividing walls characterized in that the sealing between the movable circular walls (2', 22) limiting the annular space (2) for the collection of clarified water and the vessel

bottom (1) are carried out by means of U-section sealing annular gaskets (60—61) which cause sealing on both sides of each circular wall.

7. A process for the recovery of fibre from a liquid mixture employing a plant as claimed in any preceding claim characterized in that the dam (7) rotates to cause a rise (h) substantially corresponding to the thickness of the fibre layer (4).

8. A process as claimed in claim 7, characterized in that inlet and outlet flows to and from the vessel (1) are adjusted to obtain a rise (h) corresponding to the thickness of the fibre layer (4).

Patentansprüche

1. Flotationsanlage zur Wiedergewinnung von Fasern mit einem runden eine Achse (100) aufweisenden Tank (1), der die zu behandelnde Flüssigkeitsmischung enthält, wobei im Tank (1) eine radial angeordnete Trennwand enthalten ist, die sich um die Achse (100) dreht, dadurch gekennzeichnet, daß die Trennwand als mitnehmende Stauwand (7) ausgebildet ist, deren oberer Rand (70) mit einem Trog (71) verbunden ist, sodaß der auf der Stirnseite der Stauwand verursachte Druck örtlich den Stand der Flüssigkeitsmischung erhöht und dabei die schwimmende Faserschicht (4) über den oberen Rand (70) erhöht, sodaß die Fasern in den Trog (71) gelangen.

2. Flotationsanlage zur Wiedergewinnung von Fasern nach Anspruch 1, dadurch gekennzeichnet, daß der drehbaren Stauwand (7) in ihrer Drehrichtung gesehen, ein mit Öffnungen (31') versehenes radiales Rohr (31), ein einen radialen Kanal bildenden Trog (71) mit einem schrägen Boden und eine Ausladung (75), die vorzugsweise eine Einheit mit der Stauwand (7) bildet, folgen, wobei die Anordnung so gestaltet ist, daß das zugeführte Flüssigkeitsgemisch veranlaßt wird, durch die Öffnungen (31') einem schlangenartigen Weg (76) in Gegenströmung zur Drehrichtung der Stauwand zu folgen.

3. Flotationsanlage zur Wiedergewinnung von Fasern nach den Ansprüchen 1 und 2, gekennzeichnet durch ein sich radial erstreckendes Auffangrad (8) mit gegebenenfalls regelbaren Schaufeln das im wesentlichen senkrecht über der Stauwand (7) montiert ist und sich mit der Stauwand selbst dreht, wobei sich das Auffangrad (8) auch um eine waagrechte Achse dreht, sodaß sein Schaufel (82) in die Faserschicht (4) eintaucht und auf diese Weise die Fasern in den Sammelbereich bringt.

4. Flotationsanlage zur Wiedergewinnung von Fasern nach Anspruch 3, dadurch gekennzeichnet, daß sich das radiale Auffangrad (8) um die genannte Achse in einer zur Drehrichtung der Stauwand entgegengesetzten Richtung dreht.

5. Flotationsanlage zur Wiedergewinnung von Fasern nach Anspruch 1 und 2, dadurch gekennzeichnet, daß die Öffnungen (31) des radialen Rohres (31) nach unten gerichtet sind, um eine

senkrechte nach unten gerichtete Strömung zu verwirklichen und/oder daß die Fasern nach Verlassen der Auffangzone einem nach unten gerichteten Weg folgen.

6. Flotationsanlage zur Wiedergewinnung von Fasern nach den vorstehenden Ansprüchen mit wenigstens vier konzentrischen voneinander durch bewegliche Trennwände getrennten Zonen, dadurch gekennzeichnet, daß die Abdichtung zwischen den beweglichen runden Wänden (2', 22), die den ringförmigen Raum (2) zum Ansammeln des gereinigten Wassers begrenzen, und dem Boden des Trogs (1) durch U-förmige Ringdichtungen (60—61), die die Abdichtung auf beiden Seiten jeder runden Wand bestimmen, verwirklicht ist.

7. Verfahren zur Wiedergewinnung von Fasern aus einem Flüssigkeitsgemisch, für das eine Anlage nach den vorstehenden Patentansprüchen verwendet wird, dadurch gekennzeichnet, daß sich die Stauwand (7) zur Verwirklichung einer Erhöhung (h) die im wesentlichen der Dichte der Faserschicht (4) entspricht, dreht.

8. Verfahren nach Anspruch 7, dadurch gekennzeichnet, das die Eingangs- und Ausgangsströme in den Tank und aus dem Tank (1) regelbar sind, um die der Dichte der Faserschicht (4) entsprechende Erhöhung zu erhalten.

Revendications

1. Installation de flottation pour la récupération de fibres qui comporte une cuve circulaire (1) avec un axe (100) et contenant un mélange de liquide à traiter en comprenant dans ladite cuve (1) une paroi ou cloison radiale qui tourne autour dudit axe (100), caractérisée en ce que la paroi a la forme d'un barrage ou batardeau à débordement dont le bord supérieur (70) est relié à un bac (71) de façon que la pression déterminée sur le côté avant du barrage élève localement le niveau du mélange en soulevant ainsi au dessus du bord supérieur (70) la couche de fibres flottantes (4) qui enfin arrivent au bac (71).

2. Installation de flottation pour la récupération de fibres selon la revendication 1, caractérisée en ce que le barrage ou batardeau (7) tournant est suivi — par rapport à la direction de rotation du barrage lui-même — par un tube radial (31) pourvu d'ouvertures (31'), par un bac (71) qui forme un canal radial ayant un fond incliné et enfin par une saillie (75), de préférence formant

un complexe unique avec le barrage (7), la disposition étant telle qu'elle amène le mélange de liquide alimenté à travers les ouvertures (31') à suivre un parcours en serpentif (76), à contre-courant par rapport à la direction de rotation du barrage ou batardeau.

3. Installation de flottation pour la récupération de fibres selon les revendications 1 et 2, caractérisée par un élément tournant (8) de collecte, qui s'étend radialement et présente des palettes éventuellement réglables, et qui est monté de manière sensiblement verticale au-dessus du barrage ou batardeau (7) et tourne avec ce dernier, ledit élément (8) tournant aussi autour d'un axe horizontal de façon à faire plonger sa palette (82) dans la couche (4) des fibres de manière à transporter les fibres vers la zone de collecte.

4. Installation de flottation pour la récupération de fibres selon la revendication 3, caractérisée en ce que l'élément radial (8) tourne autour dudit axe horizontal dans une direction opposée à celle de la rotation du barrage.

5. Installation de flottation pour la récupération de fibres selon les revendications 1 et 2, caractérisée en ce que les ouvertures (31') du tube radial (31) sont orientées vers le bas de façon à créer un courant vertical dirigé vers le bas, et/ou que les fibrers, après la zone de collecte, suivent un parcours descendant.

6. Installation de flottation pour la récupération de fibres selon les revendications précédentes, comportant au moins quatre zones concentriques essentiellement séparées par parois ou cloisons mobiles, caractérisée en ce que l'étanchéité entre les parois circulaires mobiles (2', 22), qui limitent la chambre annulaire (2) pour la récupération de l'eau clarifiée et le fond de la cuve (1) est assurée au moyen de garnitures annulaires d'étanchéité à section en U (60—61) qui serrent sur les deux côtés de chaque paroi circulaire.

7. Procédé pour la récupération de fibres contenues dans un mélange liquide au moyen d'une installation telle que revendiquée dans les revendications précédentes, caractérisé en ce que le barrage ou batardeau (7) tourne pour créer une montée ou dénivellation (h) correspondant sensiblement à l'épaisseur de la couche (4) de fibres.

8. Procédé suivant la revendication 7, caractérisé en ce que les débits d'entrée et de sortie, à l'intérieur et à l'extérieur de la cuve (1), sont réglés pour obtenir une montée (h) correspondant à l'épaisseur de la couche (4) de fibres.

5

10

15

20

25

30

35

40

45

50

55

60

65

5

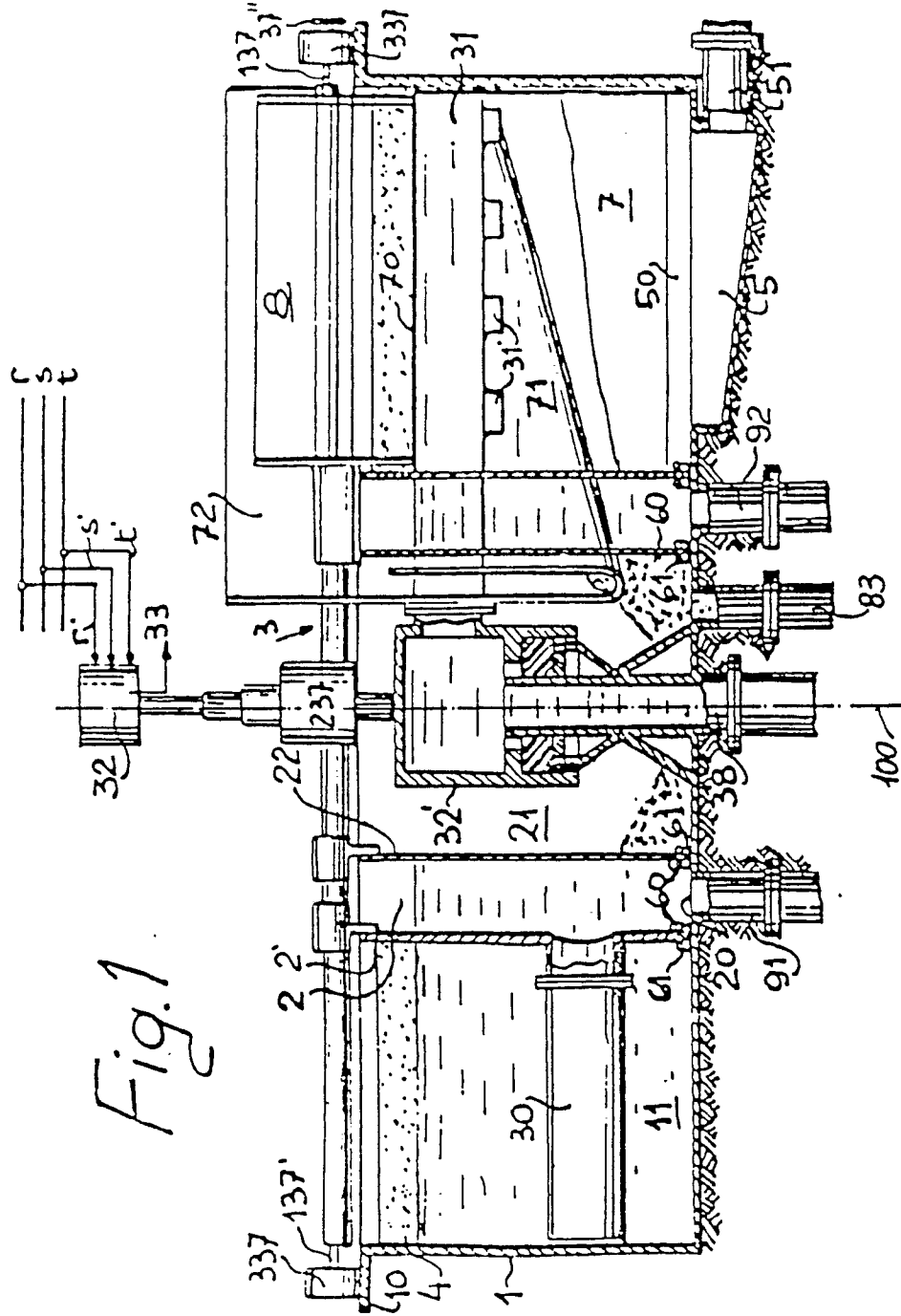

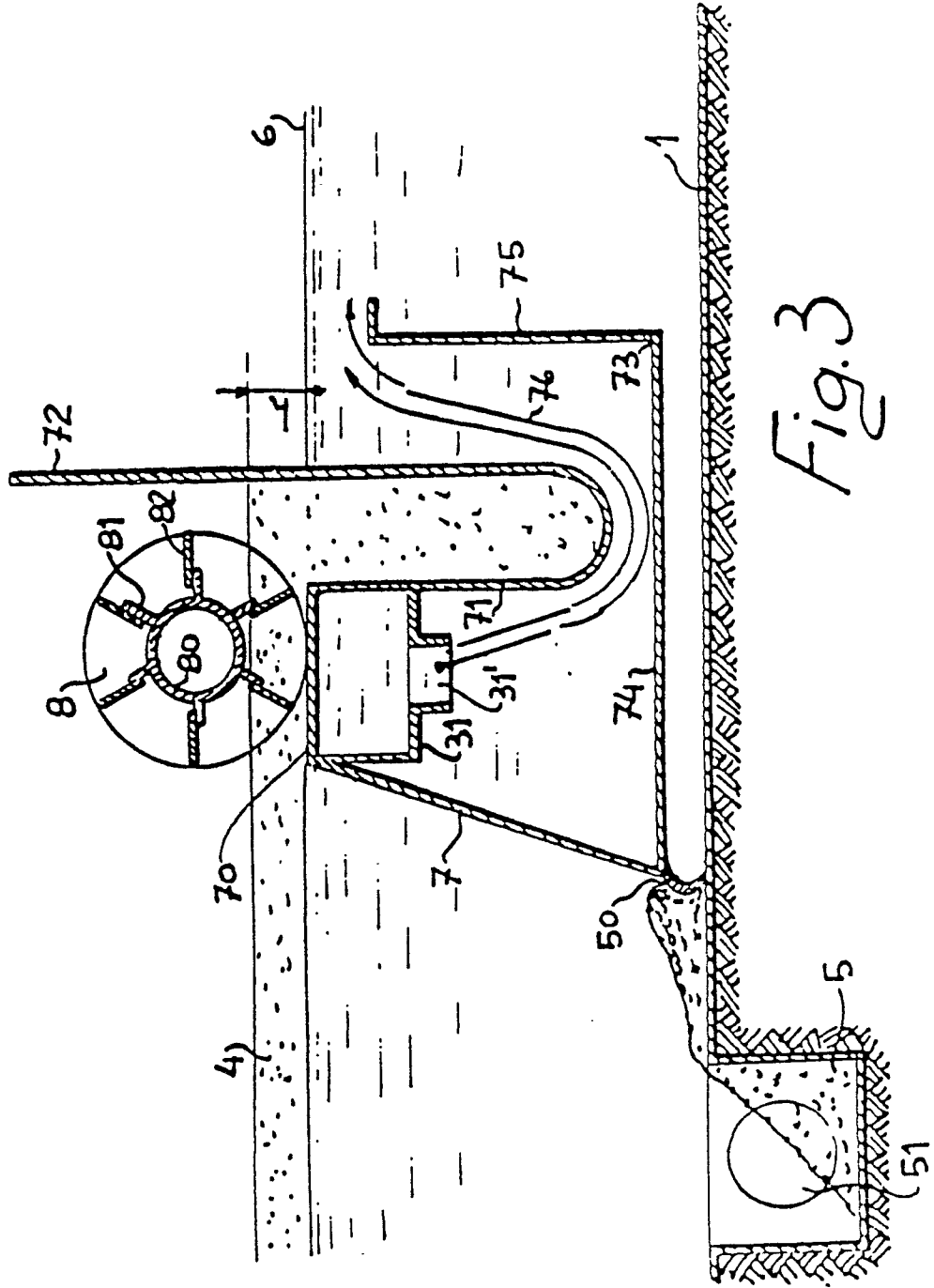

Fig. 3

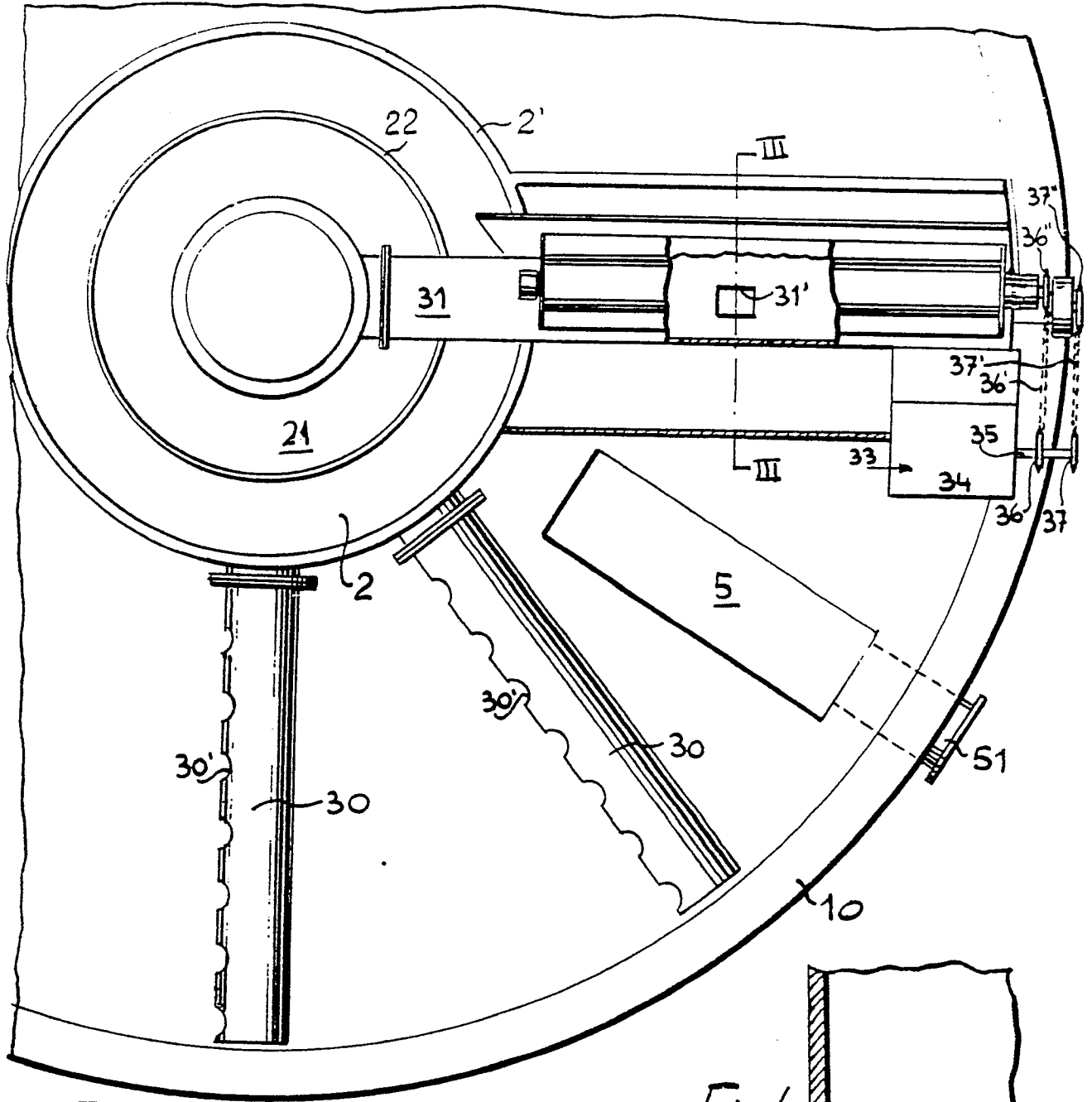

Fig. 2

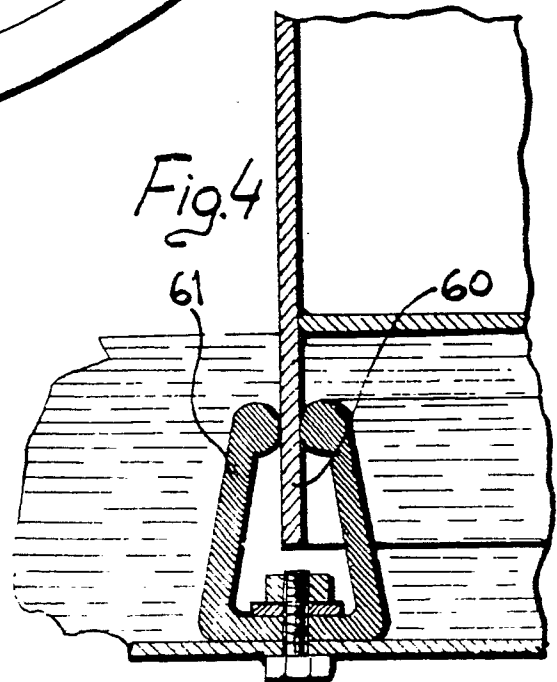

Fig. 4