

19



Europäisches Patentamt
European Patent Office
Office européen des brevets

20

Publication number:

0 016 737
A1

12

EUROPEAN PATENT APPLICATION

21 Application number: 80830014.9

51 Int. Cl.³: F 26 B 21/00

22 Date of filing: 14.03.80

30 Priority: 19.03.79 IT 477579

43 Date of publication of application:
01.10.80 Bulletin 80/20

84 Designated Contracting States:
AT BE CH DE FR GB NL SE

71 Applicant: CARRA Officine Meccaniche S.p.A.
Strada Statale della Cisa
I-42045 Codisotto di Luzzara Reggio Emilia(IT)

72 Inventor: Carra, Gianni
Via Firenze, 10
Suzzara (Mantova)(IT)

74 Representative: Pederzini, Paolo et al,
BUGNION S.p.A. Via Farini n. 37
I-40124 Bologna(IT)

54 Ventilation device for drying bricks.

57 The invention relates to a device that comprises a first frame 5 with which is integral a stanchion 1 that supports ventilation elements 2 and rests, via clutch means 7, on a second frame 9 integral with a carriage 10 movable alternately, in the directions 11 and 12, in the corridor existing between two facing frames 3 and 4 on which the bricks being dried are arranged.

The frame 5 is movable with respect to a vertical spindle 13 whose lower part is provided with an arm 15 that has a projection 16 positioned at a level lower than the lower extremity of the spindle 13.

The interception of the projection 16 against guide means 20 and 21 provided in the said corridor allows the axes of the fans 2 to orientate suitably and to rotate 180° in the region of the extremities of the corridor, and makes it possible to direct the flow of air produced by the fans 2 against the bricks placed at the extremities of the frames 3 and 4.

EP 0 016 737 A1

./...

FIG1

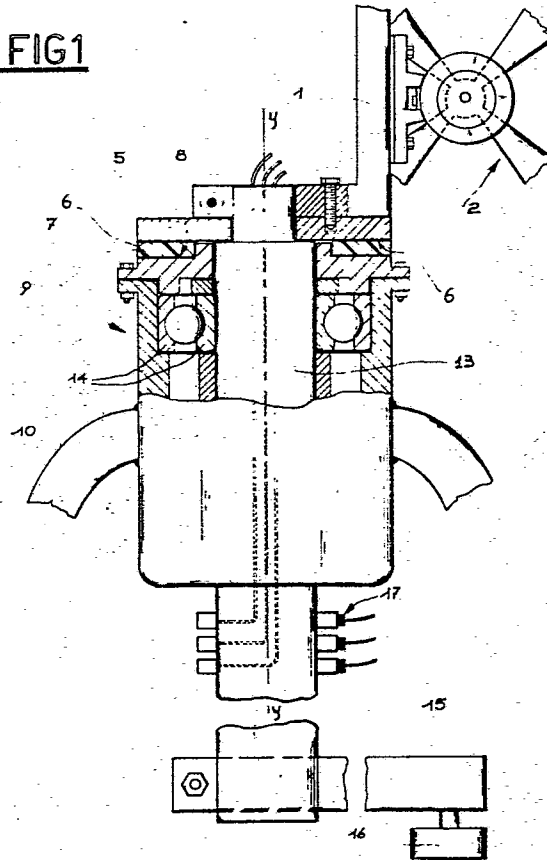
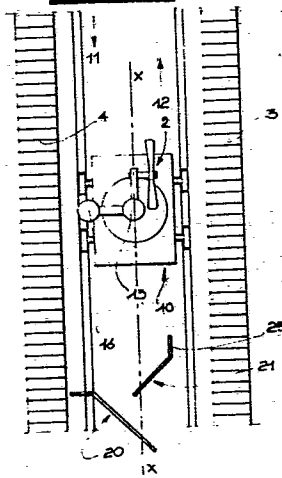

FIG2a



- 1 -

Ventilation device for drying bricks

The invention has as its subject a ventilation device for drying bricks utilizable, in particular, in drying chambers where the bricks are stacked in superposed rows on a number of parallel frames.

5

Ventilation devices are currently used in the aforementioned drying chambers which are made to slide, in the two directions, in the corridor existing between two facing frames on which there are superposed rows of bricks and these, by contributing to an increase in the relative velocity between the hot air and the article to be dried, guarantee a faster drying of the said bricks.

One problem derived from the use of the said devices consists in obtaining the most uniform possible drying of the bricks arranged on opposite sides with respect to the device itself.

In this connection various systems have been employed to date, amongst which, for example, a large fan, of a diameter at least equal to the height of the pair of facing frames that accept the bricks, supported by a carriage movable parallel in the two directions, in which the rotation direction of the impeller is reversed either when changing from one direction of movement to the opposite one, or in accordance with predetermined intervals of time, so as to ensure the same ventilation conditions (since there is a difference existing between the delivery and the aspiration of the air) for the articles to be dried. This method is not devoid of

- 2 -

problems due, above all, to down times occasioned by the acceleration and deceleration time needed for inversions in the rotation direction.

5 Another method comprises a number of fans, of a small diameter, placed vertically one on the other and fixed to a vertical stanchion which is turned by a rack, when hitting against corresponding fixed limit devices placed at the extremities of the path followed by the carriage that carries
10 the said fans, through 180° thereby directing the flow of air from the fans (which in this method rotate constantly in one and the same direction) alternately towards the facing rows of bricks arranged on the said frames. This method requires, however, the rack coupling member to be oversized
15 in order to prevent it from breaking where the limit knock takes place and, therefore, at the very time rotation starts, because of the considerable inertia of the masses that are moving.

20 The object of the present invention is, therefore, to overcome the aforementioned difficulties through the construction of a ventilation device, in particular for drying bricks, which allows the rotation and orientation of the ventilation element or elements at the most suitable angle and, contemporaneously, the said position to be stably kept, not only
25 in the region of the extremities but also along the path followed by the said device, and this by means of mechanical methods that are extremely simple and are also financially advantageous, above all in relation to the results obtained
30 therewith.

This and other objects too are attained with the device in question comprising a stanchion supporting one or more ventilation elements, characterized by the fact that it comprises:
35 a first frame integral with the said stanchion, resting, through clutch means, on a second frame integral with a carriage movable, alternately in the two directions, longitudinally.

- 3 -

ally along the corridor existing between two facing frames on which there are a number of superposed rows of bricks, and rotatable, with respect to the said second frame, around a vertical spindle; a rotation arm integral, at one extrem-
5 ity, with the lower part of the said vertical spindle, the free extremity thereof being provided with a projection placed at a level lower than the horizontal plane defined by the lower free extremity of the said spindle; and means for
10 guiding and intercepting the said projection, placed beneath the said second frame and at least in proximity of the travel extremity of the said carriage. The said guide means can, when necessary, be placed along the whole path followed by the carriage (or even partially), in such a way as to bring
15 about a continuous regulation of the direction of the ventilation flow on the bricks to be dried.

A further advantage of the device in question lies in the fact that the bricks at both extremities of the frames receive the ventilation flow. In the region of the travel
20 extremities of the carriage, the stanchion, in fact, always rotates 180° in the same direction, and this is something that was not achieved with the devices that preceded the present invention.

25 Further characteristics and advantages of the invention will become more obvious from the detailed description that follows of one preferred form of embodiment, illustrated as an unlimited example on the accompanying drawings, in which:

30 - Fig. 1 shows, diagrammatically in an axial section, the device forming the subject of the invention;
- Figs. 2a, 2b, 2c, 2d and 2e show, diagrammatically in plan view form, the device according to Fig. 1 in the various phases of rotation of the ventilation elements.

35

With reference to the accompanying figures, at 1 there is a vertical stanchion with which one or more fans 2 are integral

- 4 -

(the actual number depending upon the height of the frames 3 and 4 that contain the bricks to be dried, see Fig. 2), fixed to the upper part of a horizontal disk 5 belonging to a first frame, and resting, with the lower surface 6, 5 via a clutch member 7, on the horizontal upper surface 8 of a second frame, shown generally at 9, the upper part of which integral with a carriage 10 movable alternately, in the two directions shown with the arrows 11 and 12, in the corridor existing between the two facing frames 3 and 4, 10 parallel thereto.

The rotation of the vertical stanchion 1 around the vertical axis y-y is achieved through a spindle 13, coaxial to the disk 5, and is guided by a pair of bearings 14 placed in 15 the inside of the cylindrical body of the frame 9. The said spindle 13 projects out of the frame 9 and the lower part extends underneath the carriage 10 and has, integral with its extremity, an arm 15 which, in turn, is provided at the free extremity thereof with a roller 16 placed at 20 a level lower than that of the horizontal plane defined by the lower extremity of the said spindle 13.

Shown globally at 17 there is a set of rotating contacts (rings connected to sliding brushes) to allow an electrical 25 connection between the second frame (fixed) and the first rotatable frame in order to supply the fans.

In Fig. 2a two guides, 20 and 21, (in this specific instance shaped as shown) are placed at the two extremities of the 30 path followed by the carriage 10 in order to intercept the roller 16. The said guides slope with respect to the direction in which the carriage travels and extend on opposite sides with respect to the line x-x defined by the movement of the axis of the spindle 13. The said guides are 35 interspaced at a distance at least identical to the diameter of the said roller, so as to allow this to pass.

- 5 -

The operation of the device forming the subject of the invention will now be described with particular reference to Figs. 2a, b, c and d, as well as to the elements constituted by the guides 20 and 21 and by the arm 15.

5

Assuming now that the configuration corresponds to Fig. 2a in which the carriage 10, and with it the whole ventilation device, is moving in the direction indicated by the arrow 11 with the flow of air hitting the superposed rows of bricks placed on the frame shown at 3, the arm 13 will be positioned perpendicularly with respect to the aforementioned axis x-x until the roller 16 arrives flush up against the initial section 20a of the first guide 20 and thus gives the arm 15, and consequently the complete stanchion 1 integral there 15 with, a clockwise rotation (see Fig. 2b).

Proceeding in this manner the carriage limit configuration 2c is reached, and this corresponds to a 90° rotation of the arm 15 in which the said carriage hits against a micro- 20 switch (not shown in the figure) which reverses the motion thereof and carries the roller 16 to move the arm 15 flush up against the second guide 21 at an obtuse angle α (see Fig. 2d) which leads to a continuation of the rotation of the arm 15 (again in a clockwise direction) for a further 25 90° to a point corresponding to where the said roller has its exit 25 from the said guide 21 (see Fig. 2e). In this connection it is necessary, in order that this be possible, that the distance the extremity 25 of the guide is away from the axis x-x be identical to the length of the arm 15 since 30 otherwise a rotation of 90° would not take place.

In this way, through the presence of the two guides 20 and 21, a total rotation is thus achieved of the stanchion and, in consequence, of the fans through 180°, such, that is to 35 say, as to hit, as the carriage 10 moves in the direction indicated by the arrow 12, the frame shown at 4, and at the end of the said travel a further pair of guides attends to

returning the ventilation device to the configuration as per Fig. 2a.

It should be noted that the stated succession of phases is
5 made possible not only by the presence of the said guides
but, above all, by the presence of the clutch member which
allows the first frame to rotate with respect to the second
frame and the said position to be stably maintained until
there is a fresh reaction on the part of the arm 15.

10

In its practical form of embodiment, the invention can also
adopt forms differing from what has been described above
and, in particular, numerous modifications of a practical
nature may be made, just as the guides 20 and 21 may be of
15 a curvilinear conformation in such a way as to globally
achieve a rotation of 180° on the part of the stanchion 1,
even though the individual rotations may not be 90° , without
in any way deviating from the framework of protection af-
forded to the invention.

- 1 -

Claims

1. Ventilation device for drying bricks, comprising a stanchion 1 supporting one or more ventilation elements 2, characterized by the fact that it comprises: a first frame 5 integral with the said stanchion 1, resting through clutch means 3, on a second frame 9 integral with a carriage 10 movable, alternately in the two directions 11 and 12, longitudinally along the corridor existing between two facing 10 frames 3 and 4 on which there are a number of superposed rows of bricks, and rotatable with respect to the said second frame, around a vertical spindle 13; a rotation arm 15 integral at one extremity, with the lower part of the said vertical spindle, the free extremity thereof being provided 15 with a projection 16 placed at a level lower than the horizontal plane defined by the lower free extremity of the said spindle; and means 20 and 21 for guiding and intercepting the said projection 16, placed beneath the said second frame 9 and at least in proximity of the travel extremity of the 20 said carriage 10.

2. Device according to the preceding claim, wherein the above mentioned guide means 20 and 21 are constituted, at each travel extremity of the carriage, by at least two inclined or curved rails that spatially define an aperture for 25 the said projection to pass through.

3. Device according to the preceding claims, wherein in each of the above mentioned rails the distance in between 30 the entrance and the exit, assessed in the direction perpen-

dicular to the movement χ of the carriage, is at least identical to the length of the above mentioned rotation arm 15.

1/2'

FIG 1

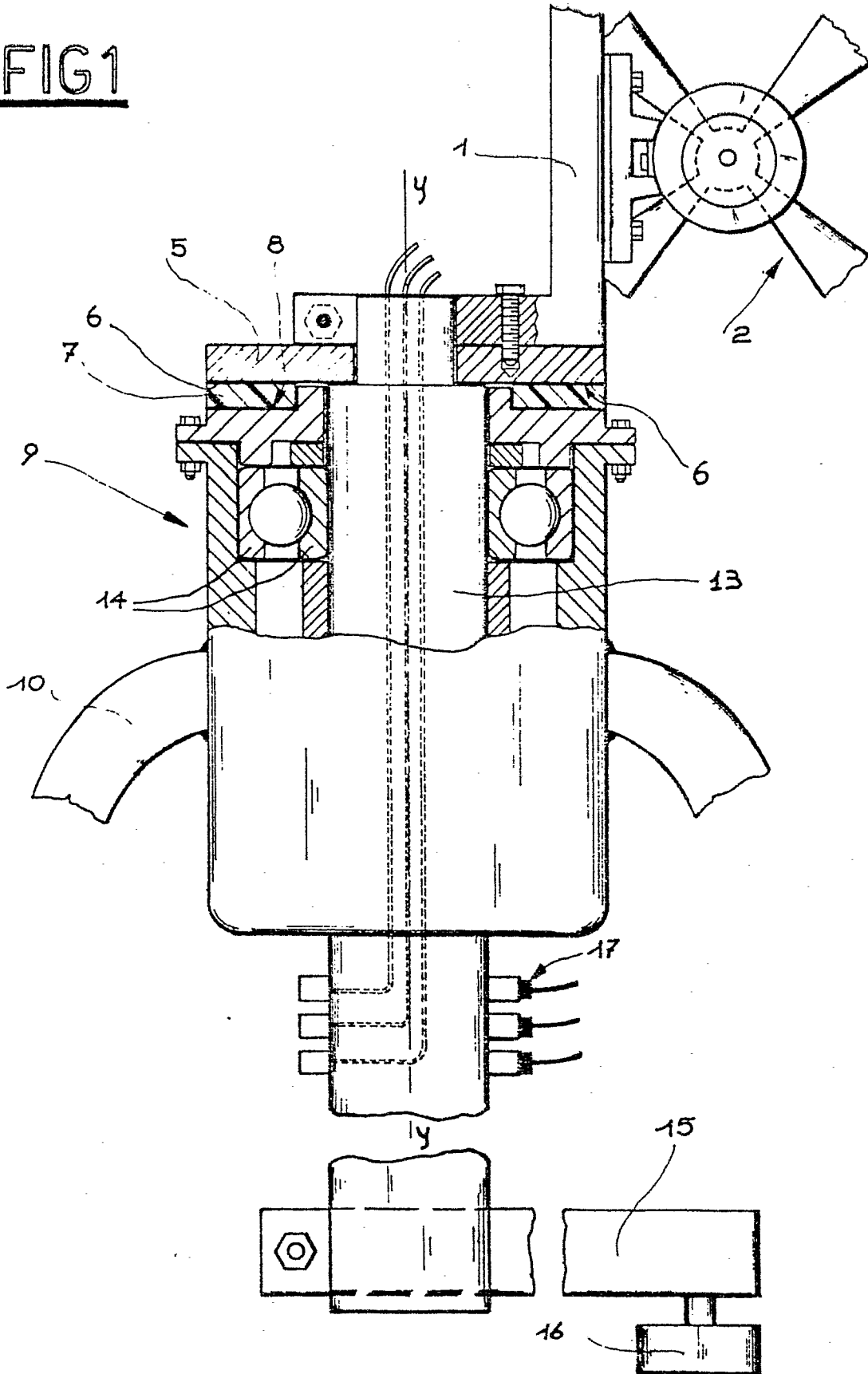

FIG 2a

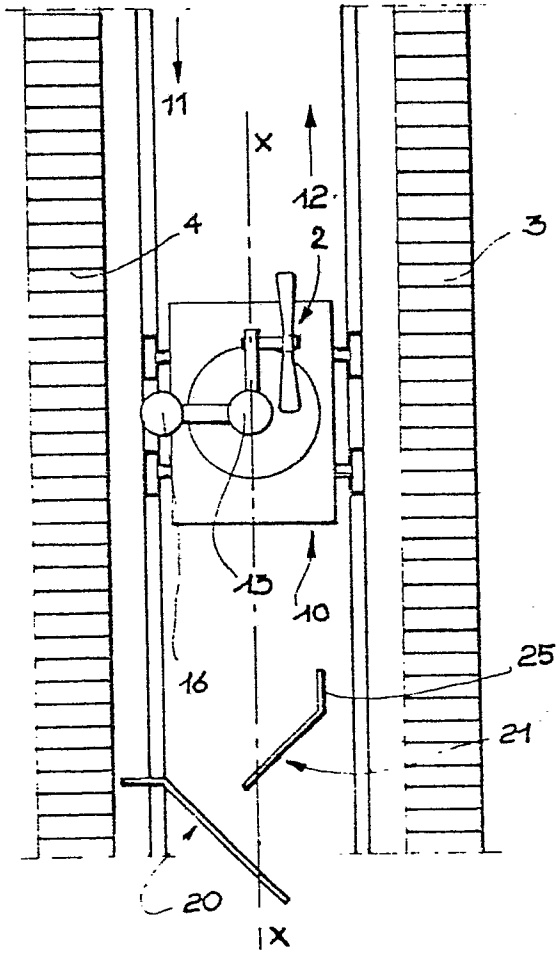

FIG 2b

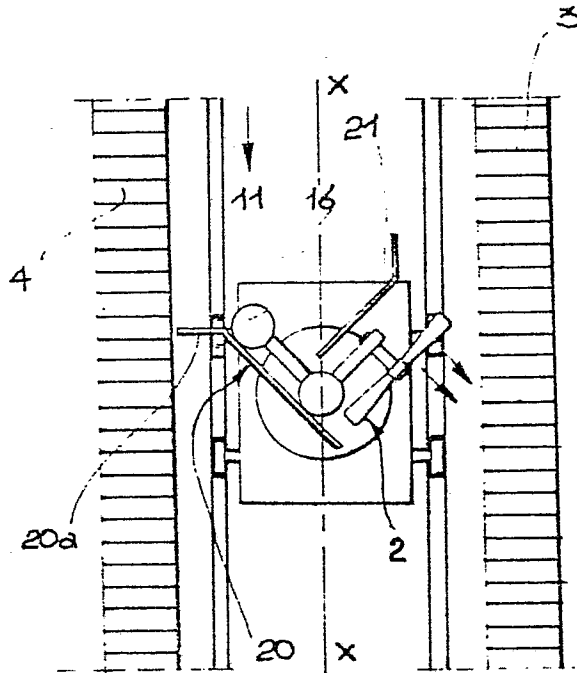

FIG 2c

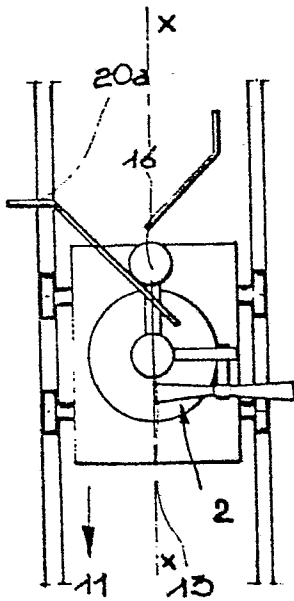

FIG 2d

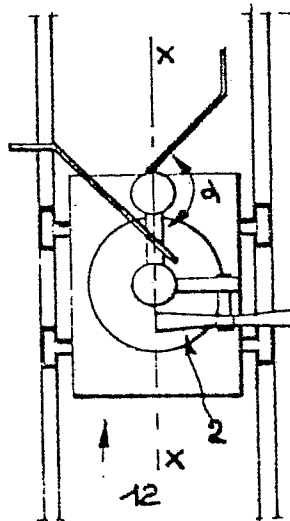
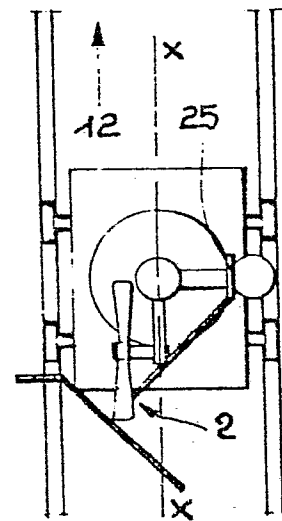

FIG 2e





| DOCUMENTS CONSIDERED TO BE RELEVANT | | | CLASSIFICATION OF THE APPLICATION (Int. Cl. 3) |
|---|--|---|--|
| Category | Citation of document with indication, where appropriate, of relevant passages | Relevant to claim | |
| | <p><u>DE - B - 2 651 850</u> (KELLER) * Whole document *</p> <p>--</p> <p><u>DE - C - 315 465</u> (BARDUCCI) * Whole document *</p> <p>--</p> <p><u>DE - A - 2 735 970</u> (WAGNER) * Whole document *</p> <p>--</p> <p><u>US - A - 2 673 403</u> (FAGIOLI) * Column 3, line 48 - column 4, line 75 *</p> <p>--</p> <p><u>FR - A - 1 166 616</u> (CADET) * Whole document *</p> <p>--</p> <p><u>US - A - 1 381 054</u> (BARDUCCI) * Whole document *</p> <p>--</p> <p><u>CH - A - 85 914</u> (BARDUCCI) * Whole document *</p> <p>--</p> <p><u>FR - A - 1 267 106</u> (PEREGO) * Whole document *</p> <p>-----</p> | <p>1</p> <p>1</p> <p>1</p> <p>1</p> <p>1</p> <p>1</p> <p>1</p> <p>1</p> | <p>F 26 B 21/00</p> <p>TECHNICAL FIELDS SEARCHED (Int.Cl. 3)</p> <p>F 26 B F 04 D</p> <p>CATEGORY OF CITED DOCUMENTS</p> <p>X: particularly relevant A: technological background O: non-written disclosure P: intermediate document T: theory or principle underlying the invention E: conflicting application D: document cited in the application L: citation for other reasons</p> <p>&: member of the same patent family, corresponding document</p> |
| A | | | |
| <p><input checked="" type="checkbox"/> The present search report has been drawn up for all claims</p> | | | |
| Place of search | Date of completion of the search | Examiner | |
| The Hague | 13-06-1980 | DE RIJCK | |