

12

EUROPEAN PATENT APPLICATION

21 Application number: 80301491.9

51 Int. Cl.³: B 65 D 25/28

22 Date of filing: 07.05.80

30 Priority: 14.05.79 US 38598

43 Date of publication of application:
26.11.80 Bulletin 80/24

84 Designated Contracting States:
AT BE DE FR GB IT NL SE

71 Applicant: **THE CONTINENTAL GROUP, INC.**
633 Third Avenue
New York, New York 10017(US)

72 Inventor: **Mascia, Carmen T.**
18 W. 125 Rodgers Court
Westmont Illinois 60559(US)

74 Representative: **Baillie, Iain Cameron et al,**
c/o Ladas & Parry Blumenstrasse 48
D-8000 München 2(DE)

54 **Paint can handles.**

57 Carrier (11,50) of plastic for a container (2) each of which comprises a flat band (10,26,45,51) for embracing the container body (4) and wedging under the upper rim (5) of the container (2), the band (10,26,45,51) being associated with a flat strap-like handle bail (13,14,25,40,57) which at its lower end is connected to the lower portion (12,29) of the band in a manner such that, upon lifting of the bail (13,14,25,40,57), the band (10,26,45,51) tends to twist, pulling the lower portion (12,29) of band outwardly whilst the upper portion (9) is forced inwardly against the can body (4) to prevent the band (10,26,45,51) from slipping over the rim (5). The twisting effect also develops a hoop tension in the band (10,26,45,51) which tightens the grip of the band (10,26,45,51) about the can body (4).

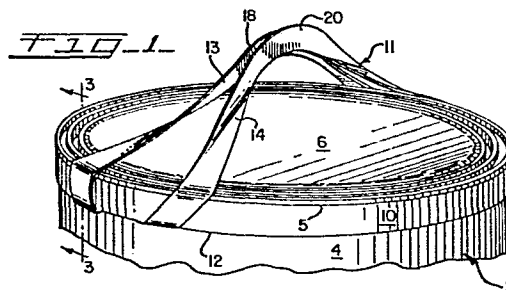

- 1 -

PAINT CAN HANDLES

This invention is directed to a carrier for containers such as paint cans.

In the prior art, paint cans have utilized a pair of bail cars which are clinched to the opposite sides of a can body. The clinching operation involves reforming the metal of the can body to provide depressions in which bell-shaped bail cars are positioned and then the metal of side wall of the depression is necked-in about an outturned flange of the bell-shaped car. This severe
10 bending of the metal fractures the protective coating which had been previously applied to the plate. Problems have arisen with water-base paints. The fractured areas rust which contaminates the product and if the areas rust through, leakers develop.

The present invention provides a carrier for a container having a body and a rim projecting radially outwardly from said body, said carrier being characterized by a flexible band of plastic material sleeved over said body and having upper and lower edges, the upper edge en-
20 gaging the underside of the rim, and bail means having lower ends connected to said band in the regions of said lower edge and operative attendant to lifting of the container by said bail means to pull said band in said regions outwardly and concurrently twisting the band and thus forcing the band at its upper edge inwardly of the can under said rim.

These and other features and advantages of the invention will become more apparent from the specification and the drawings, wherein:

Figure 1 is a fragmentary perspective view of one embodiment of the invention applied to a paint can showing the carrier in lift position;

Figure 2 is a perspective view similar to Figure 1 showing the carrier in stowed position;

Figure 3 is a sectional view taken substantially on line 3-3 of Figure 1;

Figure 4 is a perspective view similar to Figure 1 showing another embodiment of the invention;

Figure 5 is a perspective view of the embodiment of Figure 4 showing the carrier in stowed position;

Figure 6 is a cross-sectional view taken substantially on line 6-6 of Figure 6;

Figure 7 is a fragmentary perspective view of another embodiment of the invention;

Figure 8 is a fragmentary perspective of the embodiment of Figure 7 taken from another side thereof;

Figure 9 is a fragmentary side elevational view of another form of the invention and

Figure 10 is a fragmentary side elevational view taken substantially on line 10-10 of Figure 9.

In Figures 1-3, the invention is illustrated with a paint can 2 which is of conventional construction comprising a bottom (not shown), a body 4, a rim or bead 5, and a cover 6. The rim projects radially outwardly of the outer surface 7 (Fig. 2) of the can body and provides a downwardly facing groove 8, into which fits the upper edge 9 of a can-body embracing band or body strap 10 of a carrier generally designated 11, formed of plastic such as polyethylene, polypropylene etc.

The band 10 snugly embraces the can body 4 and is a flat strip of plastic material stretch-fitted over the can body.

The lower edge 12 of the band 10 is integrally

connected at diametrically opposite points with the distal ends of a pair of bails 13, 14 each of which is a strap of preferably the same thickness as the band and of the same material. These bands in the stowed position have an arcuate contour corresponding to the curvature of the can body and thus lay against diametrically opposite sides of the can body with one side 15, 16 in complimentary face to face engagement therewith thereby being unobtrusive and facilitating stacking and packaging.

10 In the lift position, as shown in Figure 1, the handles or bails 13, 14 are raised above the can and brought together at their mid-portions 18 and 20 and hand-grasped by the user. The carrier bails when lifting the can, will cant the strap as seen in Fig. 3, so that it converges upwardly toward the can body and the upper edge 9 wedges into the groove or catch 8 under the rim 5. Also, on this embodiment, the spread attachment of the bail members to the body strap insures that an extensive length

20 of the body strap 10 is canted.

A further embodiment is shown in Figures 4 to 6 wherein parts identical with the previous embodiment are identified with the same reference numerals, a single thing strip of plastic material comprising the bail 25 is used and a continuous circular flat plastic strap 26 is tightly stretched about the body of the can. The strap 26 is provided with a pair of diametrically opposed pintles 27, each of which is secured to the strap 26 adjacent to its lower edge 29. Each pintle 27 has a cylindrical shank portion 30 and an enlarged securing head 31 at its outer end. The shank 30 extends through a re-opening generally indicated 32 in an associated one of the distal ends 33 of a bail strap 25 which is also plastic. The opening 32 has circular apertures 36, 37 at opposite ends and an intervening slot portion 38 intermediate its ends. As best seen in Figure 4, upon the container being lifted, the strap slides upwardly from the position of Figure 25 and the pintle is shifted from aperture 36 to aperture

30

- 4 -

37 through deformation of the slot portion 38. Thereupon, as shown in Fig. 6, the strap 26 cants as in the previous embodiment and the upper edge of the strap 26 enters the groove 8 as seen in Fig. 6.

In the stowed position, the bail strap is swung over the upper edge of the can and the distal ends of the strap are pulled away to enter the pintles in the enlarged aperture 36. In this position, the bail is snugged against half of the can body directly beneath the
10 rim.

In Figures 7 and 8 is shown a further embodiment which is similar to Figure 6 except that the bail strap 40 in the stowed position is folded in two and is fastened at one side of the can as seen in Fig. 8 to strap 45.

For lifting the can, the strap 40 is unfastened by unfastening the outer half 41 on the strap 40 at its end 43 from the pintle 27. The inner half 39 of the bail strap is integrally formed at its free end 44 with the
20 lower edge of the body strap 45 which is stretch-fitted over the can body.

As seen in Figure 7, to fasten the end 43, it is spread at the slot portion 38 over the pintle 46 and the shank portion of the pintle is entered into opening 37. Upon lifting, the strap 45 cants and tightens about the body and the upper edge 8 thereof wedges into the groove 9 as seen in Fig. 8.

To stow the bail away, the procedure is reversed. End 44 is released from pintle 46 and applied to pintle
30 27 and the bail strap laid alongside the body.

A further embodiment is shown in Figures 9 and 10 in which common parts are identified with the same reference numerals used in connection with the previous embodiments. The plastic carrier generally designated 50 comprises a body-embracing thin band 51 which has its upper edge 52 fitted under the can bead 5. At diametrically disposed sides, there are formed integral with the band 51, outwardly extending projections 53, 54. On one of the

circumferential ends 55 of each projection 53, 54 there is integrally joined an end 56 of a plastic bail strap or handle 57. The connection is flexible in that it is thin, being weakened by an upper notch 58 formed in the juncture between the bail 57 and the associated transition load-directing projection 53, 54. The handle normally would occupy a position embracing half of the can body and for lifting, would be elevated over the can flexing the joint at 58. Since the projections 53, 54 are cantilevered, the body band 51 is canted and causes the band to tighten about the can and the upper edge 9 to wedge within the bead groove 8 when the bail handle 57 is lifted.

Thus, it will be understood that in each embodiment the bail straps are so connected to the body-embracing band that upon lifting, the strap will twist thus tightening the body strap and wedging the upper edge thereof into the groove formed between the can bead and the body.

CLAIMS

1. A carrier for a container having a body and a rim projecting radially outwardly from said body, said carrier being characterized by a flexible band of plastic material sleeved over said body and having upper and lower edges, the upper edge engaging the underside of the rim, and bail means having lower ends connected to said band in the regions of said lower edge and operative attendant to lifting of the container by said bail means to pull said band in said regions outwardly and concurrently twisting the band and thus forcing the band at its upper edge inwardly of the can under said rim.

2. A carrier according to claim 1, characterized in that said bail means is biased against the side of the container by untwisting of the band and the connections of the bail means with the band when said bail means is released.

3. A carrier according to claim 1 or 2, characterized in that said bail means and band being thin flat strips.

4. A carrier according to claim 1 or 2, characterized in that the connections of the bail means to the band comprise pintle means on one of the band and bail means and a pivot opening on the other thereof receiving the respective pintle.

5. A carrier according to claim 2 or 3, characterized in that said bail means are formed to complementarily embrace the body along arcuate contours.

6. A carrier for a container having a body and a closure therefor at its upper edge providing a bead extending radially outwardly of the body and providing a downwardly facing catch, characterized by a flexible band of plastic material circumscribing said body below said bead and having upper and lower edges and said upper edge engaging with said catch, and handle means having connecting portions attached to the band at diametrically opposite sides thereof, said portions extending downwardly from the lower edge of said band and looped upwardly along the ex-

terior side of the band in the carrying position of the handle means in which said handle means extends over the top of the can, said handle means being operative through said connecting portions to cant the upper edge of the band inwardly under the bead in the region of said connections and to pull the band at its lower edges outwardly thus tensioning the band about said can body and preventing the band from wedging over the bead.

7. A carrier according to claim 6, characterized in that the handle means comprises a pair of straps spaced at their connecting portions circumferentially of the band.

8. A carrier according to claim 6 or 7, characterized in that said carrier is made of polyethylene.

9. A carrier according to claim 6, 7 or 8, characterized in that said handle means and band are integral.

10. A carrier according to claim 1, characterized in that said handle means comprises at least one flat strip.

1/4

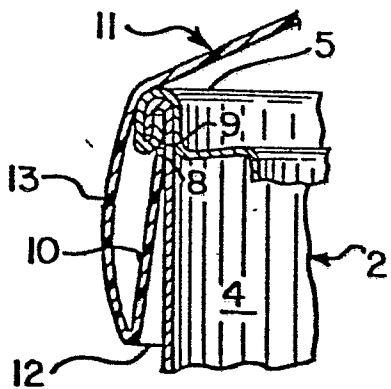
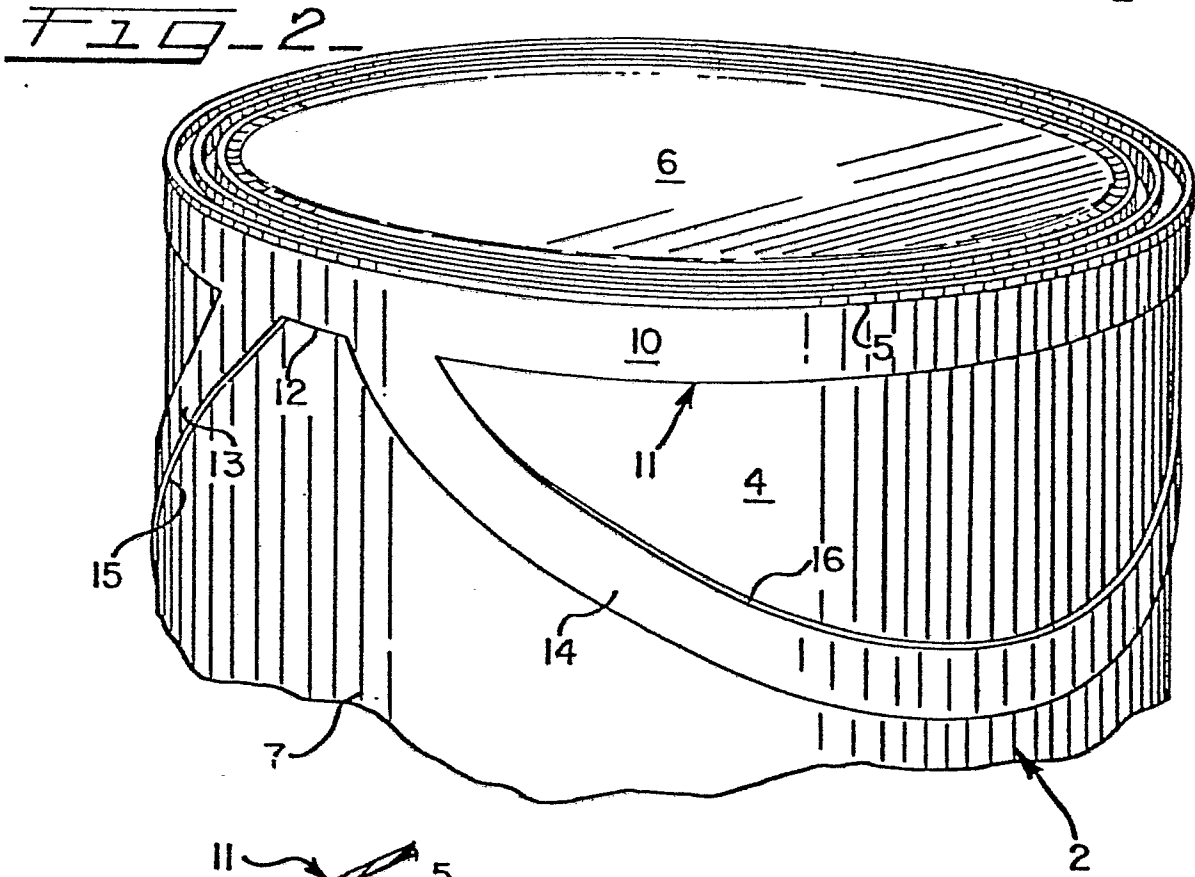
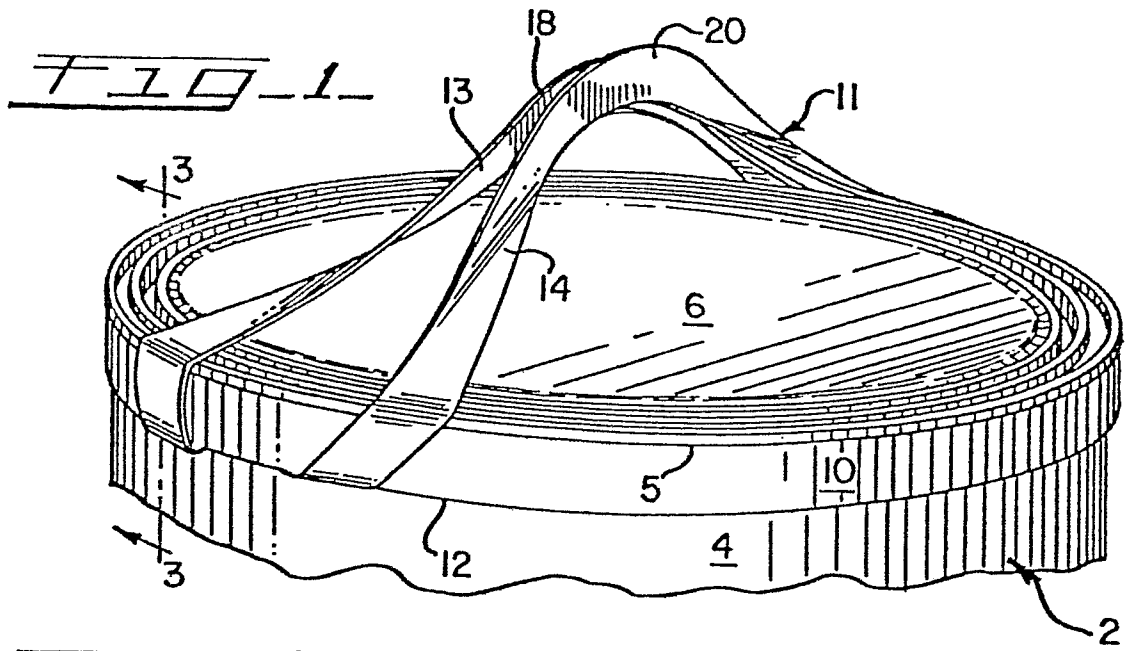

FIG. 4

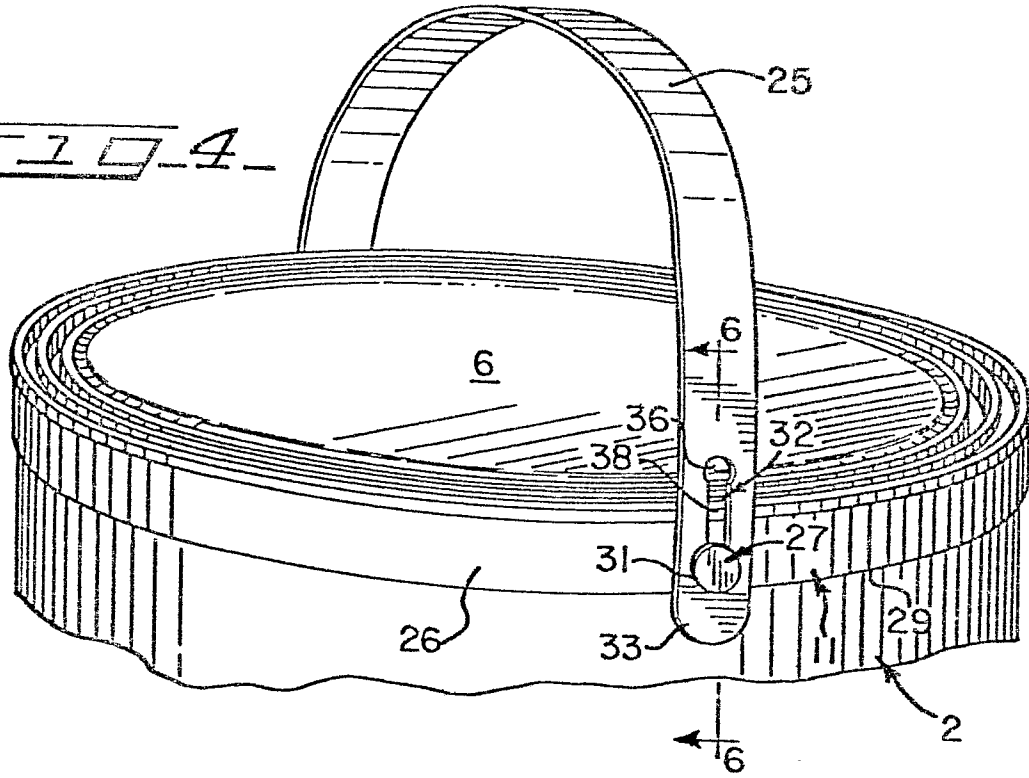

FIG. 5

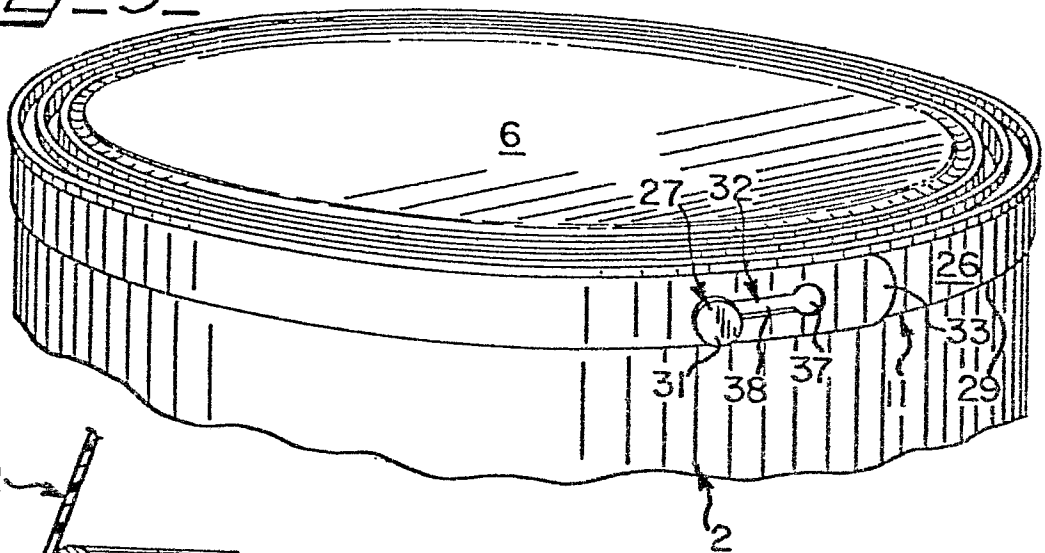
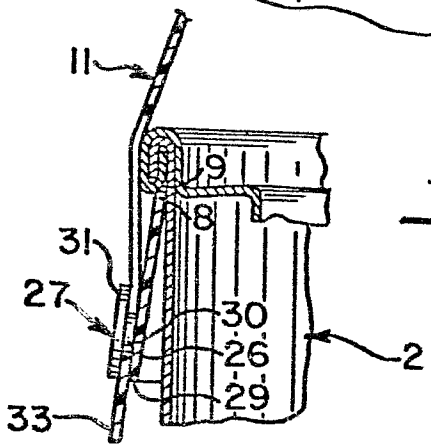

FIG. 6



3/4

FIG-7

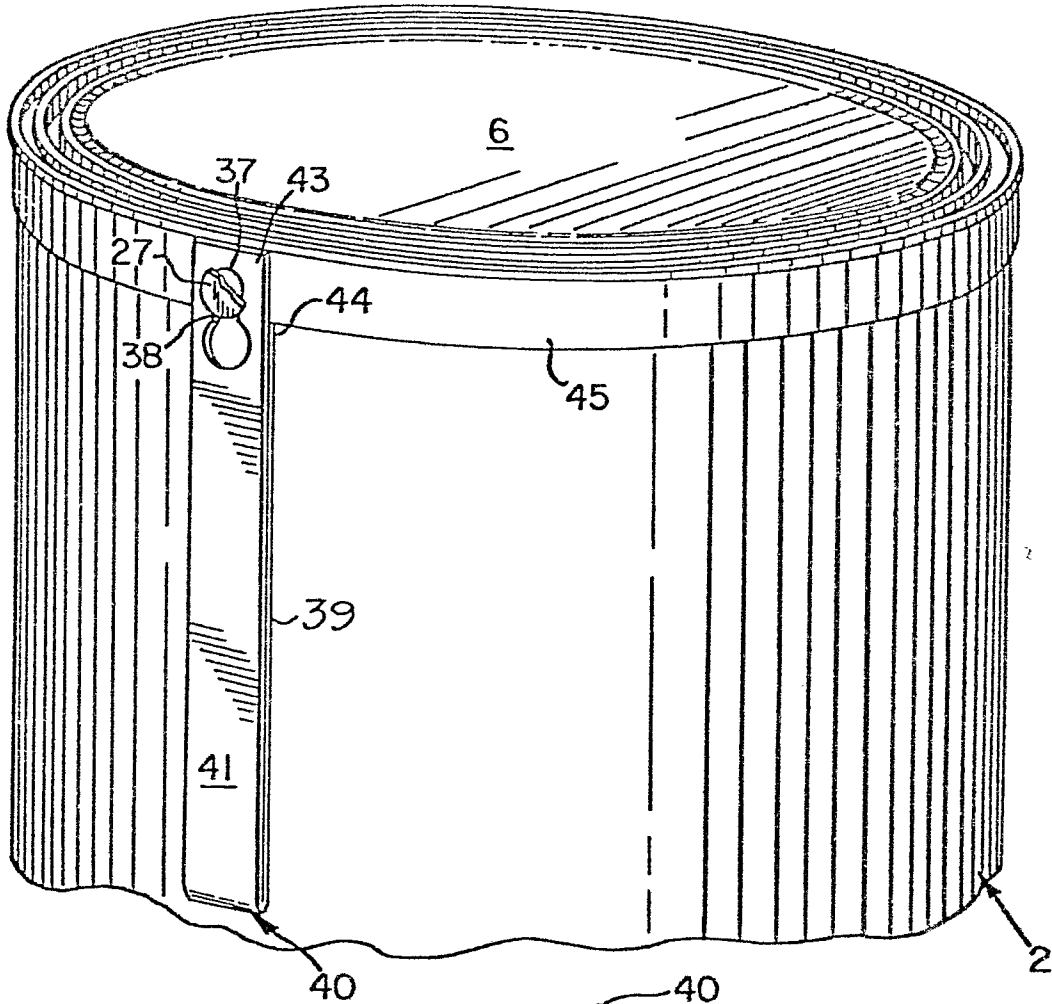
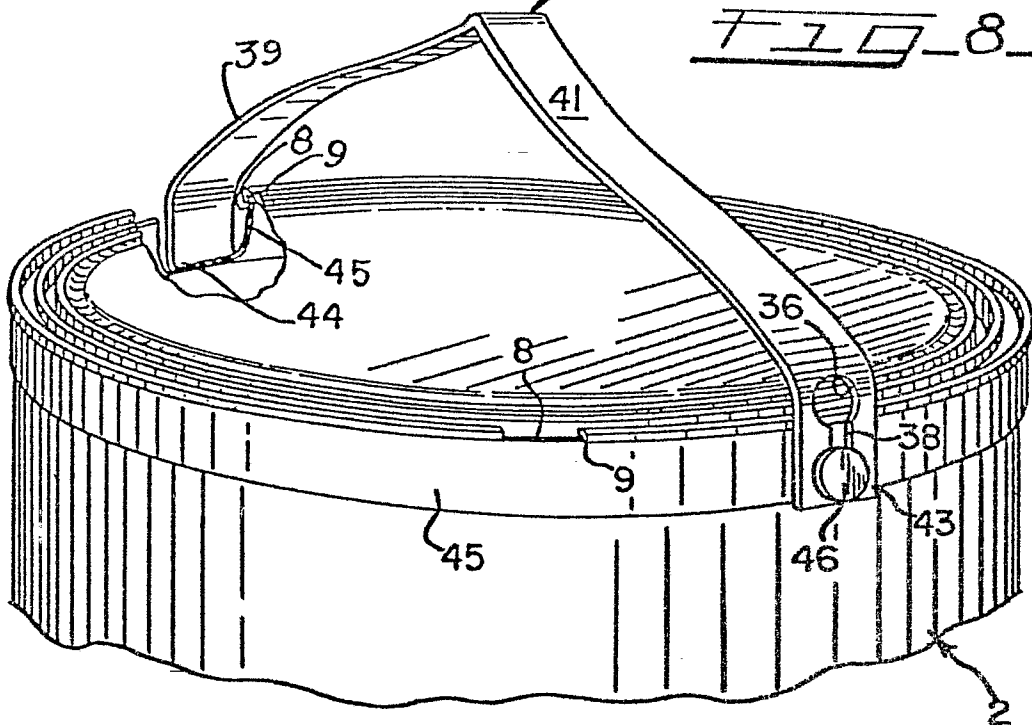
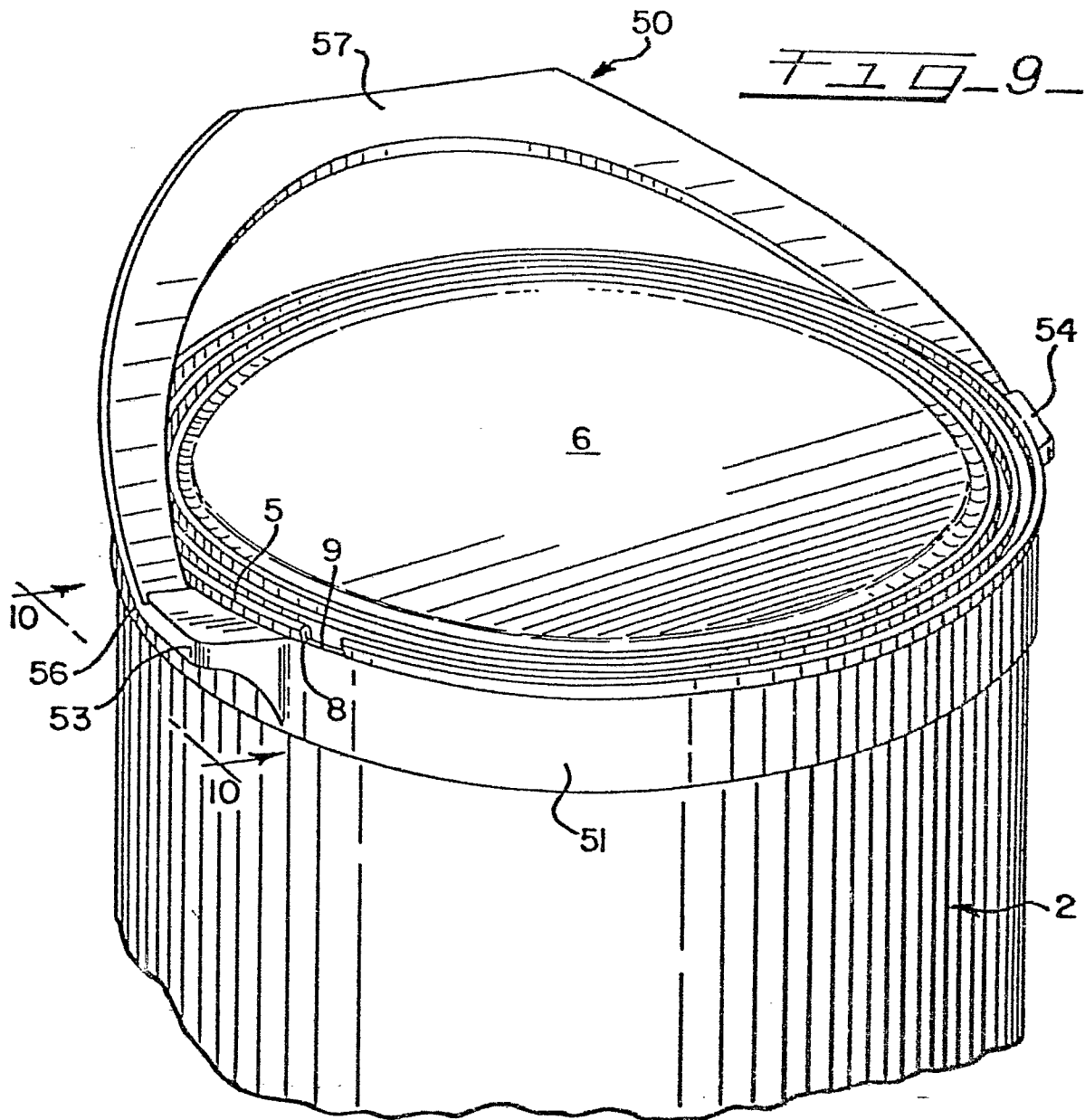
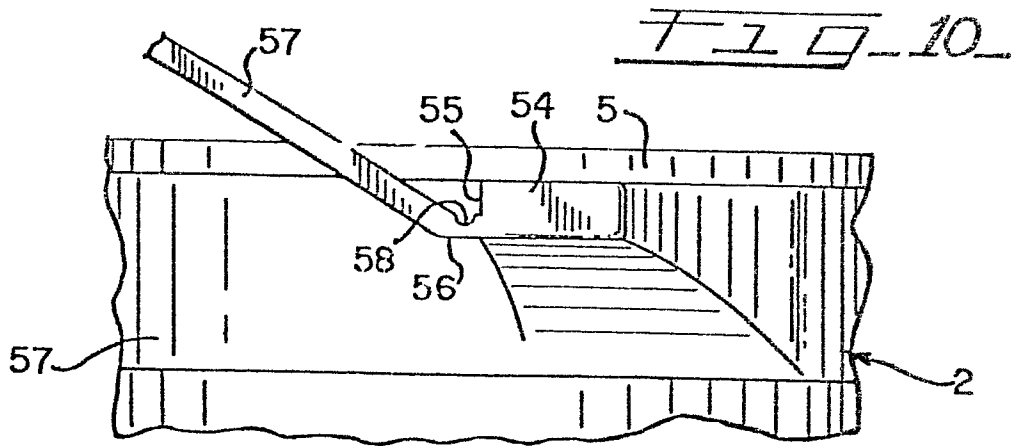

FIG-8







European Patent
Office

EUROPEAN SEARCH REPORT

0019414
Application number
EP 80 30 1491

DOCUMENTS CONSIDERED TO BE RELEVANT			CLASSIFICATION OF THE APPLICATION (Int. Cl. ³)
Category	Citation of document with indication, where appropriate, of relevant passages	Relevant to claim	
X	<u>US - A - 3 680 905</u> (ILLINOIS TOOL WORKS INC.) * The whole document * ---	1-3,5,6,8-10	B 65 D 25/28
X	<u>US - A - 3 620 410</u> (NATIONAL CAN. CORP.) * The whole document * ---	1-3,5,6,8-10	
X	<u>US - A - 2 492 464</u> (CONTINENTAL CAN CORP.) * The whole document * ---	1,4	
	<u>FR - A - 2 256 877</u> (GALLAY S.A.) * Page 3, lines 1-12; figures 1-3 * ----	7,9	TECHNICAL FIELDS SEARCHED (Int.Cl. ³)
			B 65 D
			CATEGORY OF CITED DOCUMENTS
			X. particularly relevant A: technological background O: non-written disclosure P: intermediate document T: theory or principle underlying the invention E: conflicting application D: document cited in the application L: citation for other reasons
			&: member of the same patent family, corresponding document
<input checked="" type="checkbox"/> The present search report has been drawn up for all claims			
Place of search	Date of completion of the search	Examiner	
The Hague	19.08, 1980	BAERT	