



 **EUROPEAN PATENT APPLICATION**

 Application number: **79200604.1**

 Int. Cl.³: **F 24 D 5/00**
F 28 D 7/00

 Date of filing: **19.10.79**

 Date of publication of application:
29.04.81 Bulletin 81/17

 Designated Contracting States:
BE DE FR GB NL SE

 Applicant: **Van der Iest, Sietze**
Stationsweg 103
NL-9201 GK Drachten(NL)

 Applicant: **Vorenholt, Johannes**
De Helling 38
NL-9351 DM Leek(NL)

 Inventor: **Van der Iest, Sietze**
Stationsweg 103
NL-9201 GK Drachten(NL)

 Inventor: **Vorenholt, Johannes**
De Helling 38
NL-9351 DM Leek(NL)

 Representative: **Morel, Christiaan Frederik**
MORELPATENT Laarstraat 3
NL-8166 GR Emst (Epe)(NL)

 **Heat extractor for the recovery of heat from flue gases.**

 The invention relates to a heat extractor for the recovery of heat from flue gases, such as the products of combustion from a central heating furnace, which heat extractor comprises a first impeller (2) or blower and a plurality of parallel tubes (1), around which a stream for example fresh air generated by the first impeller (2) flows in a direction transversely to the longitudinal axes (3) thereof.

In the flue gases of a central heating system energy is lost as the flue gases are blown off in the free air as they still contain heat. By the use of tubes of a rectangular cross-section and a second impeller (4), which suck the flue gases through the tubes (1), the flue gases can be cooled down to room temperature.

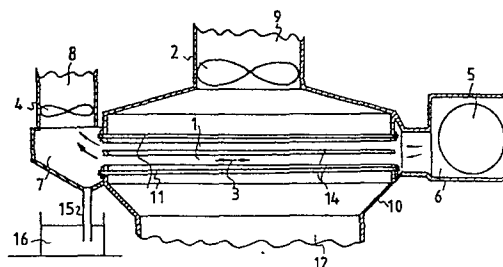

Fig. 1

- 1 -

Heat extractor for the recovery of heat from flue gases.

The invention relates to a heat extractor for the recovery of heat from flue gases, such as the products of combustion from a central heating furnace, which heat extractor comprises a first impeller or blower and a plurality of parallel tubes, around which a stream for example fresh air generated by the first impeller flows in a direction transversely to the longitudinal axes thereof.

In a central heating system, the heat, liberated by burning oil or gases, is used. Because hot flue gases can not directly be used for heating purposes, they first are guided along the outside of tubes, through which streams a liquid, in general water, or a gas. The heat from the flue gases is partly taken over by the liquid or gas and next used for the heating of houses, buildings etc..

After the heat is partly taken over, flue gases still have a relatively high temperature (300 to 600°C); generally flue gases, although they have a relatively high temperature and thus still contain useful energy, are blown off into the open air. A lot of energy is wasted.

According to the invention this aim is reached with a heat extractor by, that the tubes in cross-section are about rectangular and that they are mounted such that the direction of the stream of fresh air is along the long legs of the rectangular, i.e. perpendicular to the narrow side of the tubes. In such a heat extractor according to the invention the cooling surface of the hot flue gases becomes maximal and the

tubes will cause a minimum of resistance in the stream of fresh air.

In a preferred embodiment of the heat extractor according to the invention, the heat extractor comprises a second impeller or blower, which suck the flue gases through the parallel tubes. Normally, in a chimney the draught is kept up by the high temperature of the flue gases, which causes the exhaust of the gases into the open air. By the use of a second impeller the draught is kept up artificially, consequently the flue gases can be cooled down near room temperature. Along the tubes the first impellor blows fresh air, that after being warmed up by the flue gases can be used for heating purposes. Consequently the efficiency of a central heating system provided with a heat extractor according to the invention, will increase, as all the heat from the flue gases is used, because the flue gases can be cooled down to room temperature.

The invention will now be described with reference to one embodiment shown in the accompanying drawings. In the drawings:

Figure 1 is a sectional view of the heat extractor according to the invention;

Figure 2 is a partially sectional, top view of the heat extractor according to figure 1;

Figure 3 is a cross-section of one of the tubes.

Figure 1 shows a sectional view and figure 2 a top view of a heat extractor for the recovery of heat from flue gases according to the invention. In this embodiment of the heat extractor a plurality of tubes 1 are mounted parallel to each other. By means of a first impeller 2 fresh air is sucked from the outside and than blown along the outside of the parallel tubes 1 transversely to the longitudinal axes 3 thereof. By means of a second impeller 4 the hot flue gases are sucked through an inlet 5, an expansion room 6 and the tubes 1 into a header 7 and than blown into the open air by a chimney 8.

The fresh air, generated by the first impeller 2, is sucked from the outside and than blown along the outside of

the tubes 1 transversely to the longitudinal axes 3 thereof. The fresh air is guided through an inlet conduit 9, a casing 10, in which the tubes 1 are mounted by means of ties 11, and through an outlet conduit 12 and directly employed for heating
5 purposes. At regular distance to the tubes 1, undulated sheets 13 are connected, for example welded. This sheets 13, do accelerate the heat transmission from the tubes to the fresh air; a second feature of this sheets is that the fresh air current is better guided along the outside of the tubes.

10 Preferably the bottom side 14 of the tubes 1 are in a plane which makes a angle with the horizontal plane. Consequently the condensation of the flue gases can easily flow out the tubes 1. The water is collected into the header 7 and drained by means of a draine 15 into a collector 16.

15 Figure 3 shows a sectional view of a tube 1 of a rectangular cross-section. The direction of the stream of fresh air 17 is perpendicular to the narrow side 18 of the tube 1, i.c. parallel to the long legs 19 of the rectangular.

A great advantage of using a first and a second impeller
20 is that if there would arise a leakage and flue gases could escape from the tubes into the fresh air current, because the first impeller is placed before the tubes, it will create a over pressure, and because the second impeller is placed after the tubes it will create a depression in it, there
25 will be no risk flue gases do escape into the fresh air current.

30

35

- 1 -

1. Heat extractor for the recovery of heat from flue gases, such as the products of combustion from a central heating furnace, which heat extractor comprises a first impeller or blower and a plurality of parallel tubes, around which a stream for example fresh air generated by the first impeller flows in a direction transversely to the longitudinal axes thereof, characterized in, that the tubes in cross-section are about rectangular and that they are mounted such that the direction of the stream of fresh air is along the long legs of the rectangular, i.e. perpendicular to the narrow side of the tubes.

2. Heat extractor according to claim 1, characterized in, that the heat extractor comprises a second impeller or blower, which suck the flue gases through the parallel tubes.

3. Heat extractor according to one of the claims 1 or 2, characterized in, that the tubes are placed at an angle with the horizontal plane, such that the outlet opening is lower than the inlet opening of the tubes.

4. Heat extractor according to one of the claims 1, 2 or 3, characterized in, that at regularly distance undulated sheets are connected, for example welded, to the tubes.

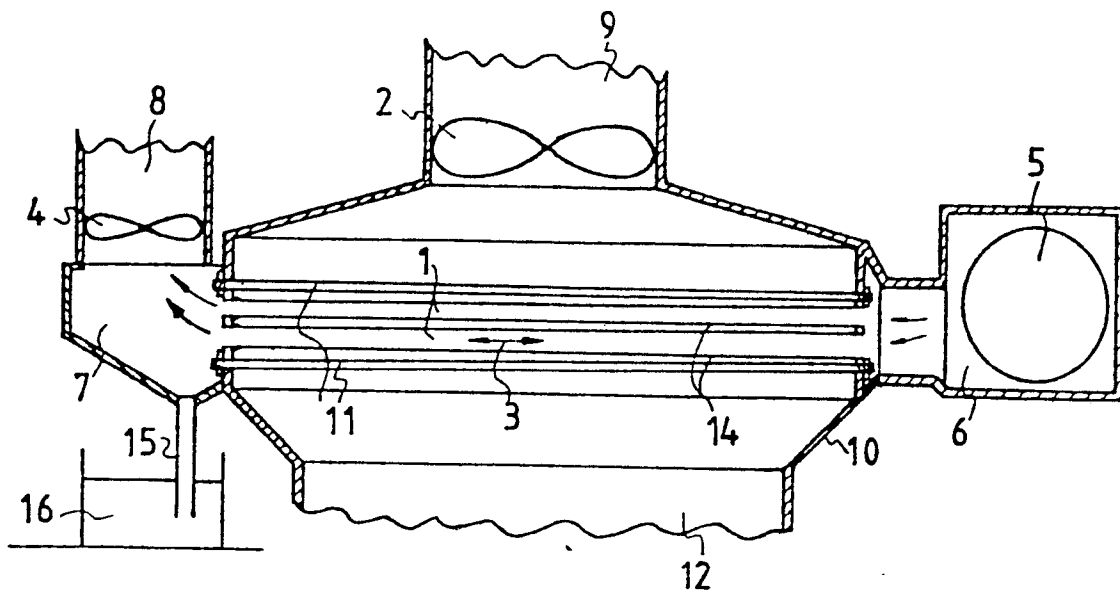

Fig:1

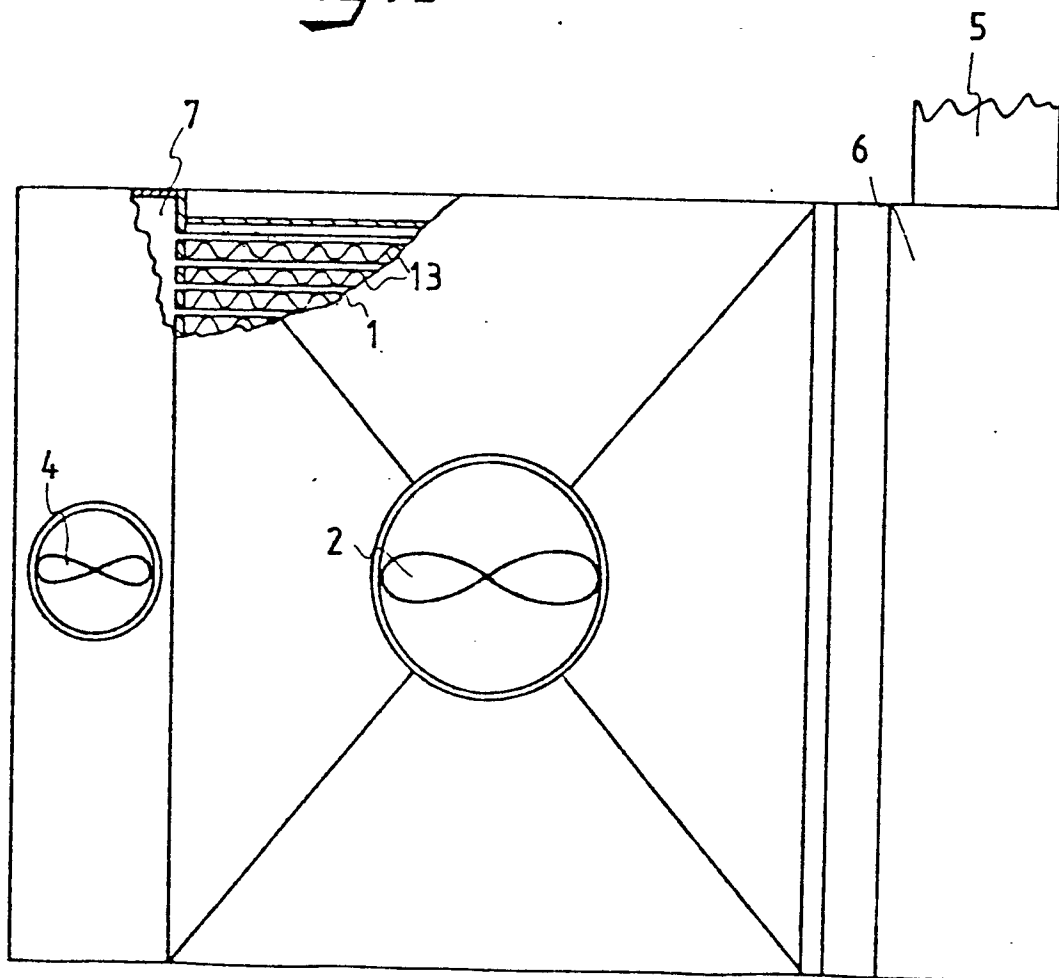

Fig:2

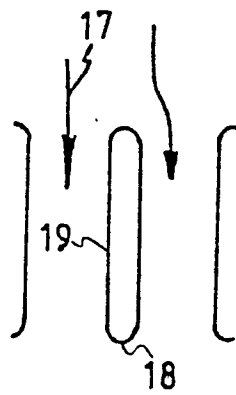

Fig:3



DOCUMENTS CONSIDERED TO BE RELEVANT			CLASSIFICATION OF THE APPLICATION (Int. Cl.3)
Category	Citation of document with indication, where appropriate, of relevant passages	Relevant to claim	
A	DE - A1- 2 731 391 (HAUGG) * page 22, paragraph 1 * --	1	F 24 D 5/00 F 28 D 7/00
	US - A -1 795 055 (TAYLOR et al.) * column 2, lines 3 to 7 * --	1	
	GB - A - 1 432 779 (APPLEGATE) * fig.; position 15 * --	2	
	DE - A1 - 2 700 182 (S.A. DES USINES CHAUSSON) * fig. 1, position 2 * --	4	TECHNICAL FIELDS SEARCHED (Int.Cl.3)
	US - A -2 579 821 (HOHNSTEIN) * complete document * ----	1	F 24 D 5/00 F 24 H 1/00 F 24 H 3/00 F 28 D 7/00 F 28 F 1/00
<input checked="" type="checkbox"/> The present search report has been drawn up for all claims			CATEGORY OF CITED DOCUMENTS X: particularly relevant A: technological background O: non-written disclosure P: intermediate document T: theory or principle underlying the invention E: conflicting application D: document cited in the application L: citation for other reasons &: member of the same patent family, corresponding document
Place of search Berlin	Date of completion of the search 11-06-1980	Examiner PIEPER	