

19



Europäisches Patentamt  
European Patent Office  
Office européen des brevets

11 Publication number:

**0 027 481  
A1**

12

**EUROPEAN PATENT APPLICATION**

21 Application number: **79302308.6**

51 Int. Cl.<sup>3</sup>: **E 05 D 3/06**

22 Date of filing: **23.10.79**

43 Date of publication of application:  
**29.04.81 Bulletin 81/17**

84 Designated Contracting States:  
**AT BE DE FR NL SE**

71 Applicant: **P.C. HENDERSON GROUP LTD.**

**Romford, Essex RM3 HUL(GB)**

72 Inventor: **Harris, Donald Stover**  
**4307 Myerwood Lane**  
**Dallas Texas 75234(US)**

74 Representative: **Rooney, Paul Blaise et al,**  
**D. YOUNG & CO. 10 Staple Inn**  
**London, WC1V 7RD(GB)**

54 **Door hinge mechanism and sectional slide-over door equipped with such a hinge.**

57 A hinge mechanism is provided for hingedly interconnecting twodoor panel elements (11,12) which are located with edge portions thereof substantially adjacent to one another in a closed position of the elements. The mechanism includes first and second base members (1,2) each provided with spaced apart first and second pivots (3,4) and (5,6) and attachable one to each of the door panel elements, and at least two elongated substantially rigid straps (7,8) pivotally attachable one at one end to the first pivot (3) of the first base member (1) and at the other end to the second pivot 6 of the second base member (2) and the other at one end to the second pivot (4) of the first base member (1) and at the other end to the first pivot (5) of the second base member (2). The pivots are so arranged and at least one of the straps (7) is shaped to abut the first pivot (3) of the base member (1) adjacent the strap end attached to the second pivot (4) of that base member, when the mechanism is attached thereto and in the closed position, thereby to provide the mechanism with flexural stiffness against movement of the door panel element edge portions, in the closed position, towards the mechanism.

**EP 0 027 481 A1**

./...

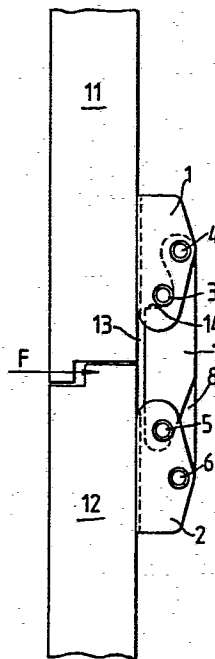

FIG. 1.

TITLE MODIFIED  
see front page

DOOR HINGE MECHANISM

This invention relates to a door hinge mechanism for hingedly interconnecting two door panel elements which are located with edge portions thereof substantially adjacent to one another in a closed position, such as is the case with, for example, industrial sectional slide-over doors.

One of the problems with such industrial sectional slide-over doors is the insertion therein of a hingedly movable wicket door, as the use of currently available hinge mechanisms for the wicket door usually results in a drastic reduction of the strength and thus the wind resistance of the combined slide-over and wicket doors. In order to combat this reduction of strength and wind resistance it has hitherto been necessary undesirably to limit the size of such combined slide-over and wicket doors. It is thus desirable to provide a door hinge mechanism with improved flexural stiffness to provide combined slide-over and wicket doors with greater strength and wind resistance when fitted thereto.

Accordingly the present invention provides a hinge mechanism for hingedly interconnecting two door panel elements which are located with edge portions thereof substantially adjacent to one another in a closed position of the elements, the mechanism including first and second base members each provided with spaced apart first and second pivots and

attachable one to each of the door panel elements, and at least two elongated substantially rigid straps pivotally attachable one at one end to the first pivot of the first base member and at the other end to the second pivot of the second base member and the other at one end to the second pivot of the first base member and at the other end to the first pivot of the second base member, the pivots being so arranged and at least one of the straps being shaped to abut the first pivot of the base member adjacent the strap end attached to the second pivot of that base member, when the mechanism is attached thereto and in the closed position, thereby to provide the mechanism with flexural stiffness against movement of the door panel element edge portions, in the closed position, towards the mechanism.

According to another aspect of the present invention there is provided a sectional slide-over door in combination with such a hinge mechanism.

Advantageously the straps are plate-like in form located side by side in, for example, contact with one another, to provide enhanced lateral stiffness. Desirably there are at least two pairs of such straps arranged side by side.

Preferably the base members of the hinge mechanism are channel shaped in form, of generally U-shaped cross section for attachment via the base of the U section to the door panel elements. The pivots, which

preferably are in the form of pins extending through the arms of the U section and across the opening between the arms, advantageously are arranged with their pivot axes in parallel spaced apart array. Preferably in each base member one pivot is located towards a leading end of the base member directed towards the other base member in the assembled position of the mechanism and the other pivot is located rearwardly of the one pivot and above it with respect to the base of the base member.

Preferably each strap is shaped so as to contact, in the normal closed position of the mechanism, the pivots to which it is not directly connected. Advantageously at least one of the straps is shaped to abut both door panel elements in the vicinity of their adjacent edge portions to provide the mechanism with flexural stiffness against excess movement of the door panel element edge portions towards the mechanism in the closed position. The hinge mechanism is intended preferably for mounting with its longitudinal axis, in the closed position of the mechanism, extending at an angle to the horizontal, more preferably substantially vertically.

A preferred embodiment of the invention is illustrated in the accompanying drawings in which :-

Figure 1 is a side view of a hinge mechanism shown mounted on two door panel elements and in a closed position.

Figure 2 is a plan view of the hinge mechanism of Figure 1,



Figure 3 is a side view similar to that of Figure 1 but showing a modified mechanism and door panel elements in an open position, and

Figure 4 is a perspective view of a sectional combined slide-over and wicket door fitted with hinge mechanism of the invention.

As shown in the drawings, the door hinge mechanism in its preferred embodiment includes a first base member 1 and a similar second base member 2. The base member 1 has spaced apart first and second pivots 3 and 4 respectively and the base member 2 has spaced apart first and second pivots 5 and 6 respectively. The hinge mechanism also includes at least two elongated substantially rigid straps 7 and 8 made of any convenient material - such as sheet metal, and pivotally attached to the pivots. As shown in Figure 2 in this embodiment the hinge mechanism includes two further such straps 9 and 10 and the straps are attached to the pivots so that strap 7 is attached at one end to pivot 4 and at the other end to pivot 5, whilst strap 8 is attached at one end to pivot 3 and at the other end to pivot 6. The optional straps 9 and 10 are similarly attached to the pivots in staggered formation with strap 9 being attached to pivots 4 and 5 and strap 10 to pivots 3 and 6.

These pivots 3, 4, 5 and 6 may be of any convenient form preferably in the form of pins as shown in the drawings. Similarly the base members 1 and 2 can have any convenient form but preferably are formed as channels with a U-shaped cross-section. In this case the pins forming the

pivots 3, 4, 5 and 6 extend through the arms of the respective U section base member across the opening between the arms as shown in Figure 2. The pins forming the pivots are arranged such that the pivot axes, that is the longitudinal axes of the pins, are spaced apart with the pivot 3 being located towards the leading end of the base member 1 directed towards the base member 2 in the assembled position of the mechanism as shown in the drawings and with the pivot 4 located rearwardly of pivot 3 and above it with respect to the base of the U section base member 1. Similarly with the base member 2 the pivot 5 is located towards the leading end of the member 2 directed towards the member 1 in the assembled position of the mechanism and the pivot 6 is located rearwardly of pivot 5 and above it with respect to the base of member 2.

Each base member 1, 2 as shown in Figures 1 and 2 is attachable in any convenient way, such as by bolting through the base of the members, to respective door panel elements 11 and 12 located with edge portions of the elements 11 and 12 substantially adjacent one another in the closed position shown in Figure 1. Thus the base member 1 is attached to the door panel element 11 and the base member 2 is attached to the door panel element 12 hingedly to interconnect the elements 11 and 12 by means of the straps 7, 8 and optionally, 9, 10 extending between the members 1 and 2.

Although the straps 7, 8 and 9, 10 may be shaped, as shown at 13 in Figure 1, not to abut the door panel elements 11 and 12 in the closed

**BAD ORIGINAL** 

position, at least one of the straps 7, 8 and 9, 10 may be shaped, preferably as shown in Figure 2, to abut both door panel elements 11 and 12 in the vicinity of their adjacent edge portions in the closed position so as to provide flexural stiffness against movement of the elements 11 and 12 in the direction of the wind pressure F. To this end the strap 7 has an abutment portion 13'. Moreover at least one and preferably each strap 7, 8 and 9, 10 is shaped so as to contact, in the normal closed mechanism position, the pivots to which it is not directly connected. Thus as shown in Figure 1 the strap 7 has a recessed portion 14, adjacent its end connected to the pivot 4, for engaging the pivot 3. The shape of this recessed portion 14 is such as to abut the pivot 3 under wind forces F and thus provide additional support against excess movement of the elements 11 and 12 towards the hinge mechanism. Furthermore the straps 7, 8 and 9, 10 by virtue of their side by side location can provide a degree of lateral stiffness to the hinge mechanism.

This hinge mechanism although primarily intended for mounting with its longitudinal axis, in the closed position of the mechanism, extending at an angle to the horizontal, such as substantially vertically as shown in the drawings, may be mounted in any other convenient orientation. A particular suitable use for the hinge mechanism is to permit the insertion of a sectional wicket door 15 in a multi-section slide-over door as shown in Figure 4.

CLAIMS

1. A hinge mechanism for hingedly interconnecting two door panel elements which are located with edge portions thereof substantially adjacent to one another in a closed position of the elements, the mechanism including first and second base members (1,2) each provided with spaced apart first and second pivots (3,4 and 5,6) and attachable one to each of the door panel elements, and at least two elongated substantially rigid straps (7,8) pivotally attachable one at one end to the first pivot (3) of the first base member (1) and at the other end to the second pivot (6) of the second base member (2) and the other at one end to the second pivot (4) of the first base member (1) and at the other end to the first pivot (5) of the second base member (2), the pivots being so arranged and at least one of the straps (7) being shaped to abut the first pivot (3) of the base member (1) adjacent the strap end attached to the second pivot (4) of that base member, when the mechanism is attached thereto and in the closed position, thereby to provide the mechanism with flexural stiffness against movement of the door panel element edge portions, in the closed position, towards the mechanism.

2. A hinge mechanism according to claim 1, wherein the straps (7,8) are plate-like in form located side by side.

3. A hinge mechanism according to claim 2, wherein the straps (7,8) are located side by side in contact with one another.

4. A hinge mechanism according to claim 2 or claim 3, having to pairs of straps (7,8 and 9,10) arranged side by side.

5. A hinge mechanism according to any one of claims 1 to 4, wherein the base members (1,2) are channel shaped in form.

6. A hinge mechanism according to claim 5, wherein the base members (1,2) have a generally U-shaped cross section, and are adapted for attachment via the base of the U section to the door panel elements (11,12).

7. A hinge mechanism according to claim 6, wherein the pivots (3,4,5,6) are in the form of pins extending through the arms of the U section and across the opening between the arms, with pivot axes of the pins being in parallel spaced apart array.

8. A hinge mechanism according to any one of claims 1 to 7, wherein in each base member (1,2) one pivot (3,5) is located towards a leading end of the base member directed towards the other base member in the assembled position of the mechanism and the other pivot (4,6) is located rearwardly of the one pivot and above it with respect to the base of the base member.

9. A hinge mechanism according to any one of claims 1 to 8, wherein each strap (7,8) is shaped so as to contact, in the normal closed

position of the mechanism, the pivots to which it is not directly connected.

10. A hinge mechanism according to any one of claims 1 to 9, wherein at least one of the straps (7,8,9,10) is shaped to abut both door panel elements (11,12) in the vicinity of their adjacent edge portions to provide the mechanism with flexural stiffness against excess movement of the door panel element edge portions towards the mechanism in the closed position.

11. A hinge mechanism according to any one of claims 1 to 10, adapted for mounting with its longitudinal axis, in the closed position of the mechanism, extending at an angle to the horizontal.

12. A hinge mechanism according to claim 11, adapted for mounting with its longitudinal axis, in the closed position of the mechanism, extending substantially vertically.

13. A sectional slide-over door in combination with a hinge mechanism according to any one of claims 1 to 12.

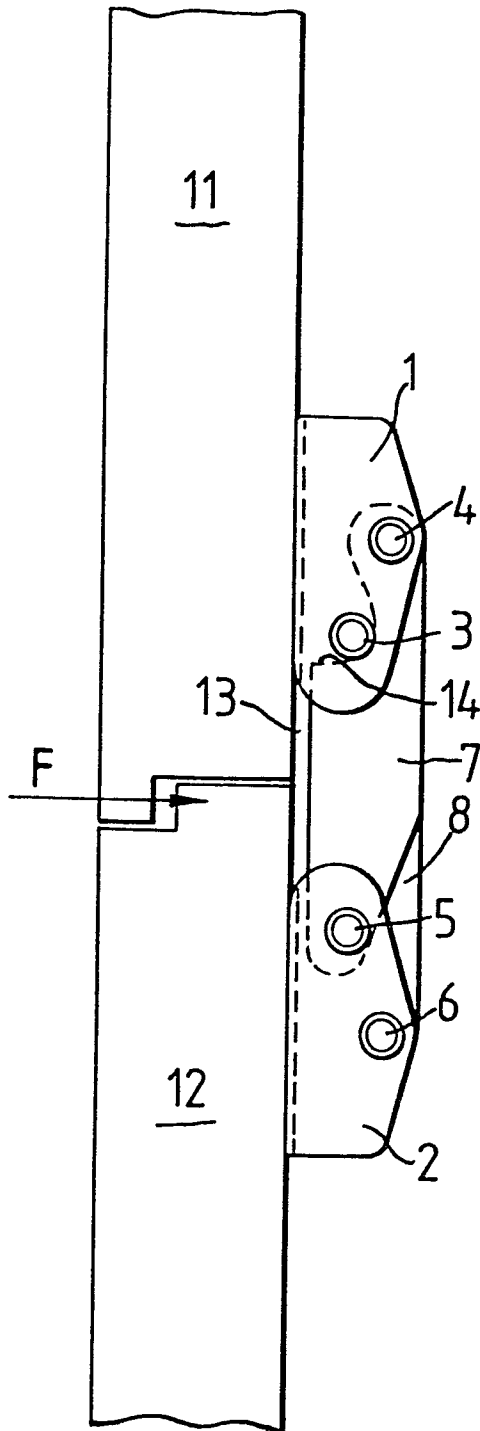

FIG. 1.

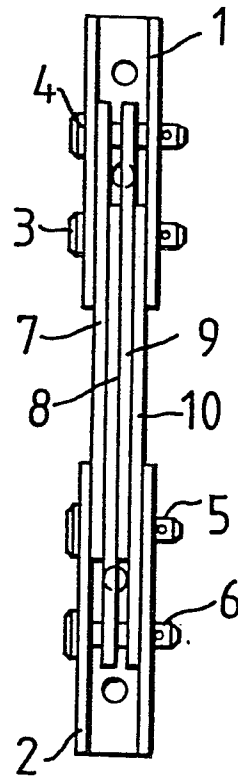

FIG. 2.

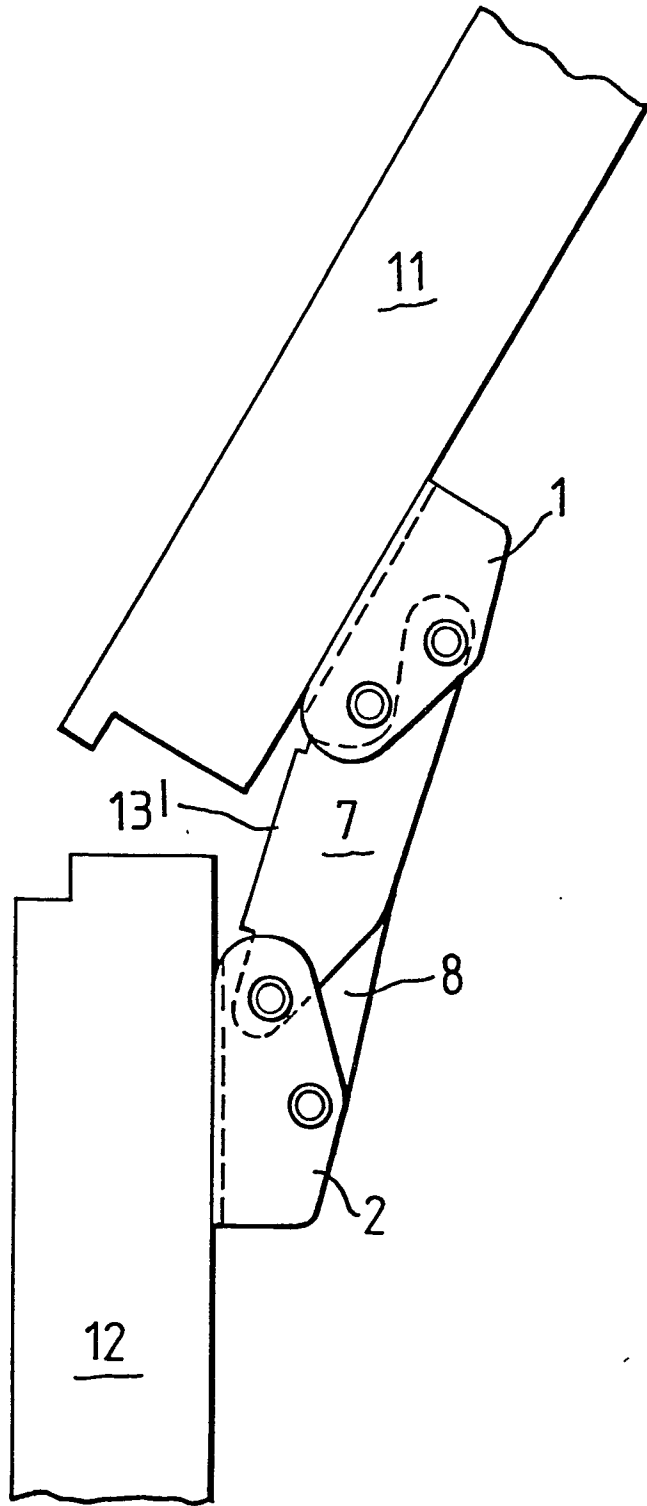

FIG. 3 .

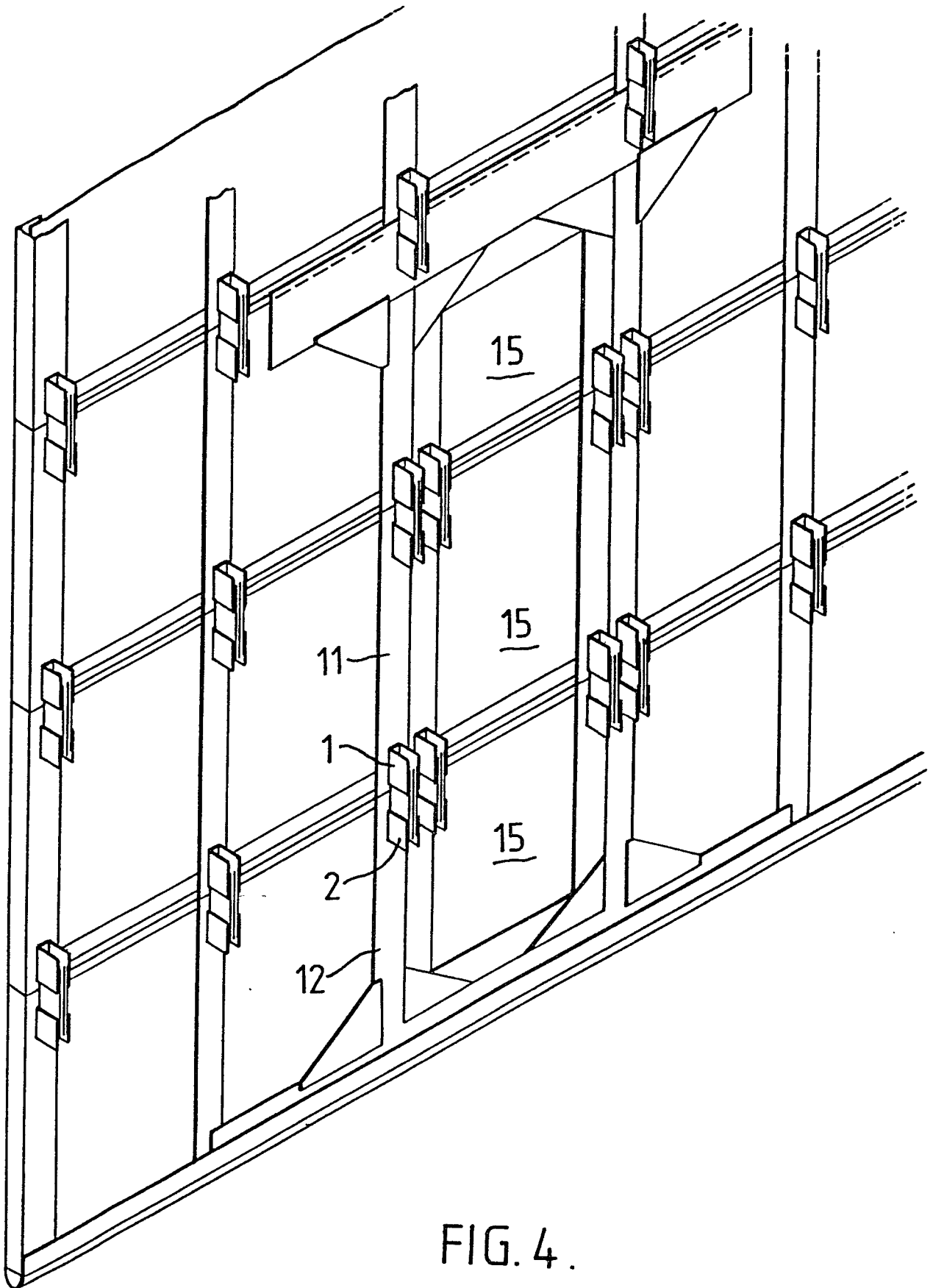



FIG. 4.



DOCUMENTS CONSIDERED TO BE RELEVANT			CLASSIFICATION OF THE APPLICATION (Int. Cl. 3)
Category	Citation of document with indication, where appropriate, of relevant passages	Relevant to claim	
X	<p><u>FR - A - 1 293 576</u> (SOCIETE CIVILE D'ETUDES ET DE RECHERCHES TECHNIQUES)</p> <p>* Page 1, column 1, paragraph 9; figures 9a,9b *</p> <p>--</p>	1-9	E 05 D 3/06
	<p><u>GB - A - 5 334 AD 1915</u> (MUSSEL-WHITE, SIMPKINS)</p> <p>* Page 2, lines 35-45; figures 1-4 *</p> <p>--</p>	1-3,5,7	TECHNICAL FIELDS SEARCHED (Int.Cl.3)
	<p><u>DE - A - 2 455 658</u> (STAHLBAU GRESCHBACH)</p> <p>* Figures 1-6 *</p> <p>--</p>	1,2,5,7,8	E 05 D
A	<p><u>US - A - 3 894 571</u> (HINCHLIFF)</p> <p>* Abstract; figures 2,3 *</p> <p>--</p>	1,11-13	CATEGORY OF CITED DOCUMENTS
			<p>X: particularly relevant</p> <p>A: technological background</p> <p>O: non-written disclosure</p> <p>P: intermediate document</p> <p>T: theory or principle underlying the invention</p> <p>E: conflicting application</p> <p>D: document cited in the application</p> <p>L: citation for other reasons</p>
<p> The present search report has been drawn up for all claims</p>			& member of the same patent family, corresponding document
Place of search	Date of completion of the search	Examiner	
The Hague	22-05-1980	NEYS	