

12

**EUROPEAN PATENT APPLICATION**

21 Application number: **81102011.4**

51 Int. Cl.<sup>3</sup>: **F 28 D 1/04**

22 Date of filing: **18.03.81**

30 Priority: **19.03.80 JP 35048/80 U**

43 Date of publication of application:  
**23.09.81 Bulletin 81/38**

84 Designated Contracting States:  
**AT DE FR**

71 Applicant: **HITACHI CONSTRUCTION MACHINERY CO,  
LTD.**  
**2-10, Uchikanda-1-chome**  
**Chiyoda-ku Tokyo(JP)**

72 Inventor: **Tanitoh, Yoshio**  
**1289-85, Onnabake Ushikumachi**  
**Inashiki-gun Ibaraka-ken(JP)**

74 Representative: **Patentanwälte Beetz sen. - Beetz jr. -  
Heidrich - Timpe - Siegfried - Schmitt-Fumian**  
**Steinsdorfstrasse 10**  
**D-8000 München 22(DE)**

54 **Annular heat exchanger.**

57 A heat exchanger having a plurality of heat exchanging units (37,38) for different fluids to be cooled, and a blower (22) around which the heat exchanging units (37,38) are arranged. Each heat exchanging unit (37,38) may include tank chambers (24 - 27) to which a fluid inlet pipe (28,29) and a fluid outlet pipe (30,31) are connected, respectively, tubes (33,34) connected between the tank chambers (24-27) and fins (35,36) attached to the tubes (33,34). The heat exchanging units (37,38) are arranged concentrically with each other around the axis (20) of the blower (22).

**EP 0 036 213 A1**

./...

FIG. 3

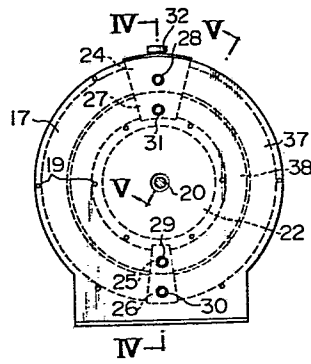
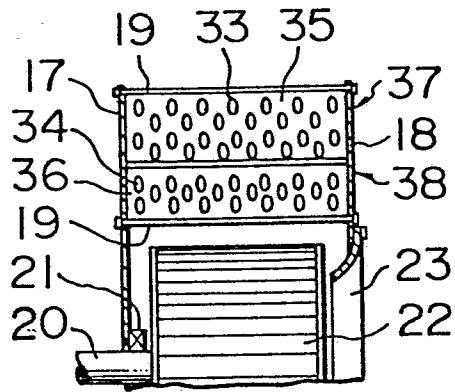

FIG. 5



## ANNULAR HEAT EXCHANGER

## 1 BACKGROUND OF THE INVENTION

The present invention relates to an annular heat exchanger having a plurality of annular heat exchanging units through which different fluids are  
5 circulated to make heat exchange with air blown by a centrifugal blower around which the heat exchanging units are arranged.

Construction vehicles and machineries are provided with a heat exchanger for cooling different  
10 kinds of fluids such as cooling water for cooling the engine, working fluid of hydraulic equipments mounted on the vehicle or machinery, lubricating oil of the engine and so forth.

Typical conventional heat exchanger for the  
15 purpose described above incorporates a combination of a plurality of heat exchanging units for different fluids and an axial blower. This conventional heat exchanger, however, generates noise of high level to cause annoyance. In order to avoid this problem, recently, there has been  
20 proposed an annular heat exchanger in which annular heat exchanging units are combined with a centrifugal blower. In this known annular heat exchanger, the heat exchanging units are arrayed in the axial direction of the centrifugal blower such that each heat exchanging  
25 unit surrounds the centrifugal blower.

1           Although the level of the noise is lowered  
considerably, this heat exchanger still involves various  
problems or drawbacks.

          Namely, as will be described later in more  
5 detail with reference to the drawings, it is not  
possible to obtain an equal cooling efficiency for all  
heat exchanging units because the air is not uniformly  
distributed to all heat exchanging units. In addition,  
the cooling power of each heat exchanging unit is imprac-  
10 tically small because each unit receives only a part  
of the air blown by the blower. Furthermore, the size  
of the heat exchanger as a whole is inevitably increased  
when three or more heat exchanging units are incorporated,  
because it is necessary to preserve the space for the  
15 pipes for introducing and discharging the fluid into  
and out of the heat exchanging unit disposed at the  
axially mid portion of the heat exchanger.

#### SUMMARY OF THE INVENTION

          It is, therefore, an object of the invention to  
20 provide an annular heat exchanger in which the heat  
exchanging units can operate substantially at an equal  
level of cooling efficiency and at high cooling power,  
while reducing the size of the heat exchanger as a  
whole.

25           To this end, according to the invention, there  
is provided an annular heat exchanger having a blower and  
a plurality of heat exchanging units for different fluids

- 3 -

1 and arranged around the blower, characterized in that the  
heat exchanging units are disposed concentrically with  
the axis of the fan.

The above and other objects, as well as advan-  
5 taneous features of the invention will become more clear  
from the following description of the preferred embodi-  
ments taken in conjunction with the accompanying drawings.

#### BRIEF DESCRIPTION OF THE DRAWINGS

Fig. 1 is an illustration of a conventional  
10 annular heat exchanger;

Fig. 2 is a sectional view taken along the line  
II-II of Fig. 1;

Fig. 3 illustrates an annular heat exchanger  
constructed in accordance with a first embodiment of  
15 the invention;

Fig. 4 is a sectional view taken along the  
line IV-IV of Fig. 3;

Fig. 5 is a sectional view taken along the  
line V-V of Fig. 3;

20 Fig. 6 is a sectional view taken along the line  
VI-VI of Fig. 4;

Fig. 7 illustrates an annular heat exchanger  
constructed in accordance with a second embodiment  
of the invention;

25 Fig. 8 is a sectional view taken along the  
line VIII-VIII of Fig. 7;

Fig. 9 illustrates an annular heat exchanger

1 constructed in accordance with a third embodiment of the  
invention; and

Fig. 10 is a sectional view taken along the  
line X-X of Fig. 9.

#### 5 DESCRIPTION OF THE PREFERRED EMBODIMENTS

Before turning to the description of the  
preferred embodiments of the invention, a description  
will be made hereinunder as to the drawbacks of the  
prior art with specific reference to Fig. 1 which is an  
10 end view of a known annular heat exchanger and Fig. 2  
which is a sectional view taken along the line II-II of  
Fig. 1.

Referring to Figs. 1 and 2, a heat exchanger  
of the prior art has sector columnar tank chambers 1  
15 to 4. The tank chambers 1 and 4 are separated from  
each other by a partition wall 5, while the tank  
chambers 2 and 3 are separated from each other by a  
partition wall 6. The tank chambers 1 and 2 are provided  
with inlet pipes 7 and 8, respectively, while the tank  
20 chambers 3 and 4 are provided with outlet pipes 9  
and 10, respectively. A cap 11 is provided on the tank  
chamber 1. The tank chambers 1 and 3 are connected to  
each other by annular tubes 12. Similarly, the tank  
chambers 2 and 4 are connected to each other by annular  
25 tubes 13. Fin plates 14 are attached to the annular  
tubes 12, 13 and are arranged radially. The annular  
tubes 12 and the fin plates 14 in combination constitute

- 5 -

1 a first heat exchanging unit 15 while the annular tubes  
13 in cooperation with the fin plates 14 constitute a  
second heat exchanging unit 16. The first and the  
second heat exchanging units 15 and 16 are arrayed in  
5 the axial direction. Side walls 17 and 18 are secured  
by means of bolts 19 to both sides of the tank chambers  
1 to 4. A reference numeral 20 designates a shaft  
extending through the side wall 17 and connected to a  
prime mover (not shown). A seal member 21 is secured  
10 to the side wall 17 to provide a seal between the shaft  
20 and the side wall 17. The shaft 20 is connected at  
its other end to a centrifugal blower 22 which is  
surrounded by the heat exchanging units 15 and 16. A  
reference numeral 23 denotes a bell mouth provided in  
15 the side wall 18.

In this annular heat exchanger, two kinds of  
liquids are circulated through respective heat exchang-  
ing units 15, 16 to make heat exchange with air which  
is blown by the centrifugal blower 22 driven by the  
20 prime mover through the shaft 20. Namely, a first and  
a second fluids to be cooled is supplied into the tank  
chambers 1 and 2 through the inlet pipes 7 and 8,  
respectively. The fluids then flow toward the tank  
chambers 3 and 4 through respective annular tubes 12  
25 and 13, so that the heat possessed by the fluids are  
radiated from the plate fins 14 attached to the annular  
tubes 12 and 13.

As the centrifugal blower 22 operates, the

1 cooling air is induced through the bell mouth 23 and is  
deflected orthogonally toward the heat exchanging units  
15, 16 to flow through the latter. Therefore, the velocity  
of air flowing through the axial end portion adjacent to  
5 the side wall 18 is smaller than that flowing through  
the axial end adjacent to the side wall 17. Namely,  
since the cooling air flows through the heat exchanging  
units 15, 16 at different velocities, it is not possible  
to equalize the cooling efficiencies of both heat  
10 exchanging units. In addition, each of the heat  
exchanging units 15 and 16 cannot receive whole part of  
the air induced through the bell mouth 23. In other  
words, a part of the air induced through the bell  
mouth 23 is made to flow through the heat exchanging  
15 unit 15 solely while the remainder of the air induced  
through the bell mouth is made to flow through the  
other heat exchanging unit 16 solely. Therefore, the  
heat radiation efficiency in each unit is comparatively  
low.

20 In the case where the heat exchanger has  
three or more heat exchanging units, it is not possible  
to arrange the inlet pipe and outlet pipe of the central  
heat exchanging unit in parallel with the shaft 20,  
unless the tank chamber of the central heat exchanging  
25 unit solely is projected radially outwardly or the inlet  
and outlet pipes are bent at 90°. In such a case, the  
maximum diameter of the annular heat exchanger is increased  
impractically.

1 Under these circumstances, the present invention  
provides an annular heat exchanger in which the cooling  
efficiencies of all heat exchanging units are equalized  
and the heat radiation efficiency of each heat exchanging  
5 unit is improved, without being accompanied by an increase  
of the maximum outside diameter of the annular heat  
exchanging unit, as will be understood from the following  
description of the preferred embodiments.

Fig. 3 shows an annular heat exchanger construct-  
10 ed in accordance with a first embodiment of the invention,  
Fig. 4 is a sectional view taken along the line IV-IV  
of Fig. 3, Fig. 5 is a sectional view taken along the  
line V-V of Fig. 3 and Fig. 6 is a sectional view taken  
along the line VI-VI of Fig. 4.

15 Referring to these Figures, the heat exchanger  
of the first embodiment has section-shaped columnar tanks  
24 to 27. For instance, tank chambers 24 and 27 are  
constructed as a unit and are separated from each other  
by a partition wall. Similarly, the tank chambers 25 and  
20 26 may be constructed as a unit and separated from each  
other by a partition wall.

Numerals 28 and 29 denote inlet pipes connected  
to the tank chambers 24, 25, while numerals 30 and 31  
denote outlet pipes connected to the tank chambers  
25 26, 27.

The tank chamber 24 is provided with a cap 32.  
The tank chamber 24 and the tank chamber 26 are connected  
to each other by annular tubes 33, while the tank

1 chambers 25 and 27 are connected to each other by  
annular tubes 34. Fin plates 35 and 36 are attached to  
annular tubes 33 and 34 and are disposed radially. The  
annular tubes 33 and the plate fins 35 in combination  
5 constitute a first heat exchanging unit 37, while a  
second heat exchanging unit 38 is constituted by annular  
tubes 34 and the fin plates 36. The first and the second  
heat exchanging units 37, 38 are arranged concentrically  
with each other.

10 In operation, two different liquids to be  
cooled are introduced into the tank chambers 24, 25  
through the inlet pipes 28, 29 and are then sent to the  
tank chambers 26, 27 through the annular tubes 33, 34.  
Meanwhile, the centrifugal blower 22 is driven through  
15 the shaft<sup>20</sup> to generate a flow of air which carries away  
the heat of the liquids from the plate fins 35, 36  
attached to the annular tubes 33, 34 in which the liquids  
to be cooled are circulated.

Fig. 7 shows an annular heat exchanger const-  
20 ructed in accordance with another embodiment of the  
invention, while Fig. 8 is a sectional view taken  
along the line VIII-VIII of Fig. 7. Referring to these  
Figures, the annular heat exchanger of this embodiment  
has annular columnar chambers 39 to 42. The tank  
25 chambers 39 and 40 are provided with inlet pipes 43, 44,  
while the tank chambers 41, 42 are provided with outlet  
pipes 45, 46. The tank chamber 39 is provided at its  
top portion with a cap 47. The tank chambers 39 and 41

- 9 -

1 are connected to each other through straight tubes 48,  
while the tank chambers 40 and 42 are connected to each  
other by means of straight pipes 49. Annular plate  
fins 50 and 51 are attached to the straight tubes 48,  
5 49. The straight tubes 48 and the plate fins 50 in  
combination constitute a first annular heat exchanging  
unit 52, while the straight tubes 49 and the plate fins  
51 constitute a second heat exchanging unit 53. The  
heat exchanging units 52 and 53 are arranged concentri-  
10 cally with each other.

In operation, two different liquids to be cooled  
are introduced into the tank chambers 39, 40 through the  
inlet pipes 43, 44 and are sent to the tank chambers  
41, 42 through the straight tubes 48, 49, respectively.  
15 Meanwhile, the centrifugal blower 22 is driven through  
the shaft 20 to produce flow of air which carries away  
the heat of the liquids from the plate fins 50, 51 attached  
to the straight tubes 48, 49 through which the liquids  
to be cooled are circulated.

20 Fig. 9 illustrates a still another embodiment  
of the invention while Fig. 10 is a sectional view taken  
along the line X-X of Fig. 9.

Referring to these Figures, the heat exchanger  
of this embodiment has about semicircular columnar tank  
25 chambers 54 to 57 and circular columnar tank chambers  
58, 59. Inlet pipes 60 and 61 are connected to the tank  
chambers 54, 55, respectively, while outlet pipes 62, 63  
are connected to the tank chambers 56, 57. The tank

- 10 -

1 chamber 54 is provided at its top portion with a cap 64.  
The tank chambers 54, 56 are connected to the tank  
chamber 58 through straight tubes 65, while the tank  
chambers 55, 57 are connected to the tank chamber 59  
5 through straight tubes 66. Annular plate fins 67, 68  
are attached to the straight tubes 65, 66, respectively.  
The straight tubes 65 and the plate fins 67 in combination  
constitute a first annular heat exchanging unit 69,  
while the straight tubes 66 and the plate fins 68 in  
10 combination constitute a second annular heat exchanging  
unit 70. The heat exchanging units 69 and 70 are  
arranged concentrically with each other.

In operation, two different liquids to be cooled  
are introduced into the tank chambers 54, 55 through  
15 inlet pipes 60, 61 and are sent to the tank chambers  
56, 57 through the straight tubes 65, 66, tank chambers  
58, 59 and the straight tubes 65, 66. Meanwhile, the  
centrifugal blower 22 is driven through the shaft 20  
to generate a flow of air which carries away the heat  
20 of the liquids from the plate fins 67, 68 attached to  
the straight tubes 65, 66 through which the liquids  
are circulated.

In this case, it is possible to dispose the  
inlet pipes 60, 61 and the outlet pipes 62, 63 at the  
25 same side of the heat exchanger, as will be clearly  
seen from Fig. 10.

Although the invention has been described  
through its preferred forms, the described embodiments

1 are not exclusive and various changes and modifications  
may be imparted thereto without departing from the scope  
of the invention.

For instance, the annular form of the heat  
5 exchanging units is not essential and the heat exchanging  
units can have various other cross-sections such as oval  
cross-section, rectangular cross-section or other poly-  
gonal cross-section. It is also possible to provide  
three or more heat exchanging units although the describ-  
10 ed embodiment has only two heat exchanging units. In such  
a case, the size of each heat exchanging unit can be  
determined as desired in proportion to the necessary  
cooling capacity. The plate fins used in the des-  
cribed embodiment can be substituted by corrugated  
15 fins to constitute, in combination with the tubes, the  
heat exchanging unit. Other types of heat exchanging  
units can be used instead of the heat exchanging unit  
mentioned above. Also, the direction of flow of fluids  
in the illustrated embodiments are not exclusive.

20 Although a single suction centrifugal blower  
is used in the described embodiments, it is possible  
to use double suction centrifugal blowers or other types  
of blowers such as axial-flow type blower. In the  
case where a single suction centrifugal blower is used,  
25 the air may be induced from the same side as the driving  
shaft. In the described embodiments, the blower is  
supported externally and driven by a prime mover mounted  
at the outside of the heat exchanger. It is, however,

1 possible to support the blower at its one or both sides  
by bearing or bearings attached to the side wall or  
walls of the heat exchanger or to attach the prime mover  
such as a hydraulic motor, electric motor or the like  
5 directly one of the side walls. Although in the des-  
cribed embodiment the cooling air is blown from the  
central portion of the heat exchanger radially outwardly,  
it is possible to arrange such that the air is directed  
radially inwardly.

10 As has been described, in the heat exchanger  
of the invention, a plurality of heat exchanging units  
are arranged concentrically so that the heat exchanger  
units receive the cooling air at an equal rate even  
when there is any uneven flow velocity distribution in  
15 the axial direction, to ensure equal cooling efficiency  
of all heat exchanging units. In addition, each heat  
exchanging unit can operate at a high heat radiation  
efficiency because each heat exchanging unit can receive  
the whole part of the cooling air blown by the blower.

20 It is also to be noted that, when three or more  
heat exchanging units are mounted in a single heat  
exchanger, it is possible to extend the inlet and  
outlet pipes connected to the central heat exchanging  
unit in parallel with the shaft of the blower, so that  
25 it is not necessary to project the tank chamber of the  
central heat exchanging body radially outwardly. Namely,  
it is possible to minimize the maximum outside diameter  
of the heat exchanger as a whole.

1           In the heat exchanger of the invention, the  
heat exchanging units may be disposed taking into account  
the order of necessity for the cooling such that the heat  
exchanging unit for the liquid having the highest demand  
5 for cooling is disposed at the radially innermost portion  
of the heat exchanger.

- 1 -

## WHAT IS CLAIMED IS:

1. A heat exchanger comprising a blower and a plurality of heat exchanging units for different fluids to be cooled arranged around said blower,  
5 characterized in that  
said heat exchanging units (37, 38) are disposed concentrically with the axis (20) of said blower (22).
2. A heat exchanger as claimed in claim 1, wherein  
10 each of said heat exchanging units (37, 38) has an annular shape.
3. A heat exchanger as claimed in claim 1, characterized by comprising annular tubes (33, 34) connected between  
15 the fluid inlet (28, 29) and a fluid outlet (30, 31) of each of said heat exchanging units (37, 38) and fins (35, 36) arranged in a heat exchanging relation to said tubes (33, 34), said inlet (28, 29) and outlet (30, 31) are arranged in parallel with the axis  
20 (20) of said blower (22).
4. A heat exchanger as claimed in claim 1, characterized by comprising two or more tank chambers (39 - 42) including a tank chamber (39, 40) connected to the  
25 fluid inlet (43, 44) of each heat exchanging unit (52, 53) and a tank chamber (41, 42) connected to the fluid outlet (45, 46) of each heat exchanging unit (52, 53), tubes (48, 49) connected between said tank chambers (39- 42) and disposed in parallel with the axis (20)  
30 of said blower (22), and fins (50, 51) arranged in heat exchanging relation to said tubes (48, 49).
5. A heat exchanger as claimed in claim 1, characterized by comprising annular tank chambers (39 - 42) connected  
35 to the fluid inlet (43, 44) and fluid outlet (45, 46) of each heat exchanging unit (52, 53), respectively, tubes (48, 49) connected between said tank chambers

(39 - 42) and extending in parallel with the axis (20) of said blower (22), and fins (50, 51) arranged in heat exchanging relation to said tubes (48, 49).

5 6. A heat exchanger as claimed in claim 1, characterized  
by comprising about semicircular tank chambers (54 - 57)  
connected to the fluid inlet (60, 61) and fluid outlet  
(62, 63) of each heat exchanging unit (69, 70), an  
annular tank chamber (58, 59) connected to said about  
10 semicircular tank chambers (54, 56; 55, 57) through tubes  
(65, 66) disposed in parallel with the axis (20) of said blower  
(22), and fins (67, 68) arranged in heat exchanging  
relation to said tubes (65, 66).

1/5

FIG. 1 PRIOR ART

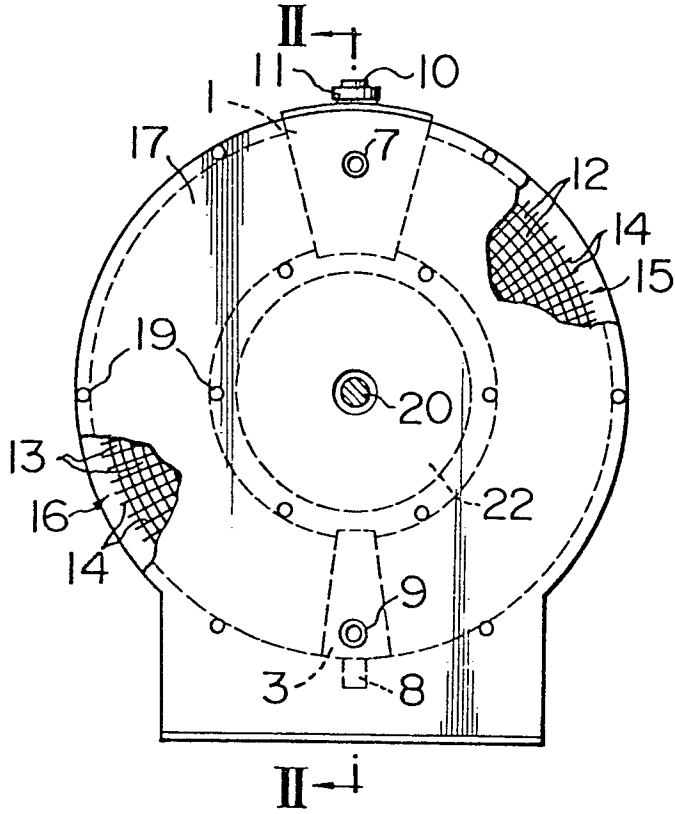

FIG. 2 PRIOR ART

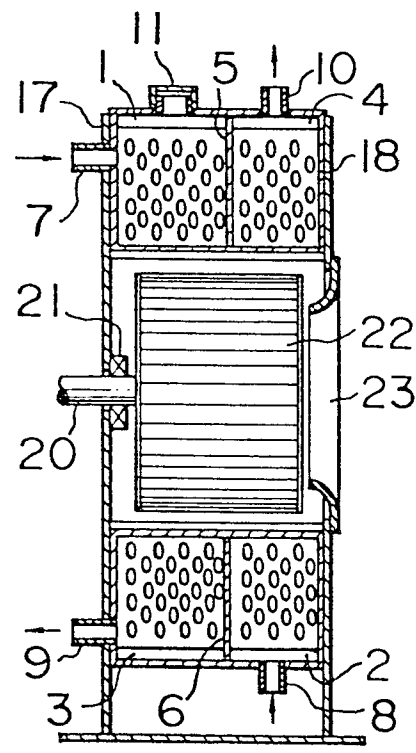

FIG. 3

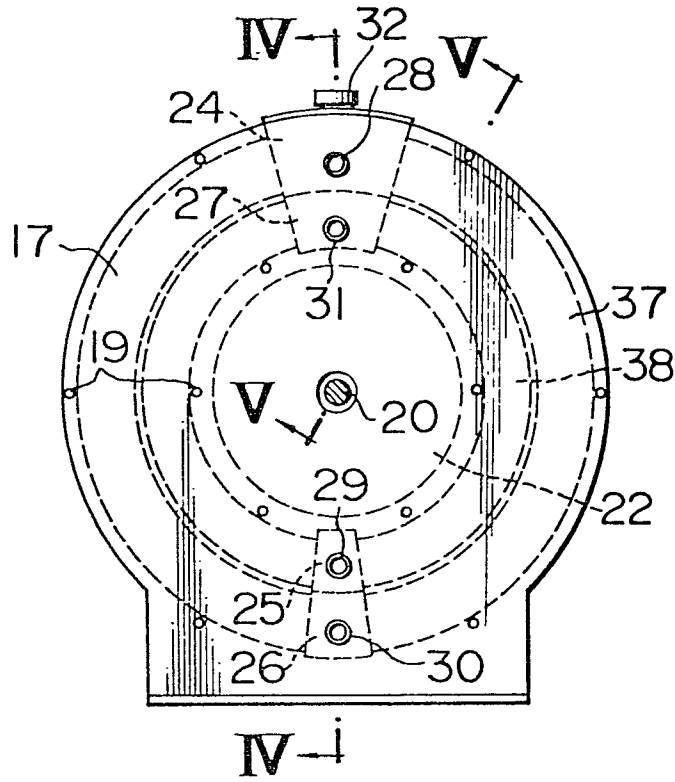

FIG. 4

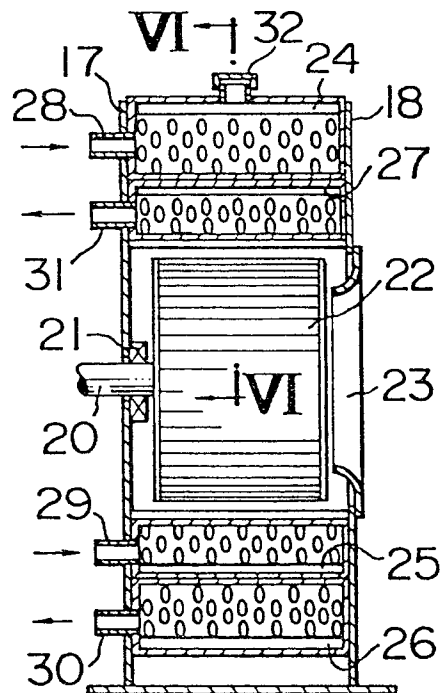

FIG. 5

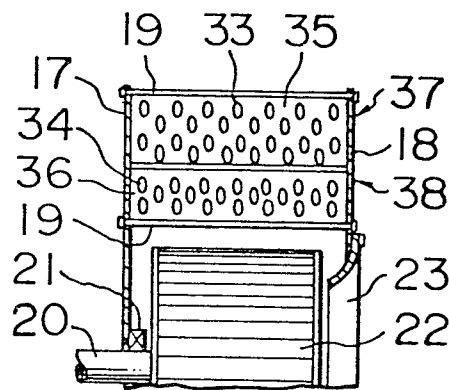
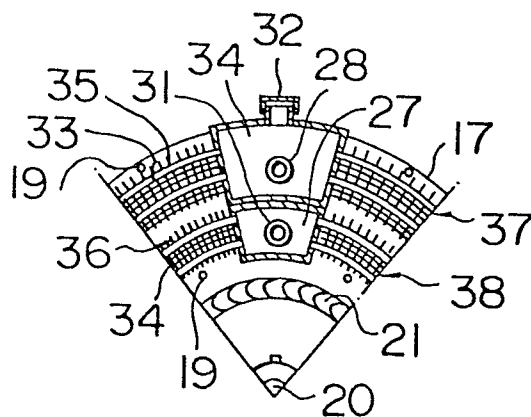

FIG. 6



4/5

FIG. 7

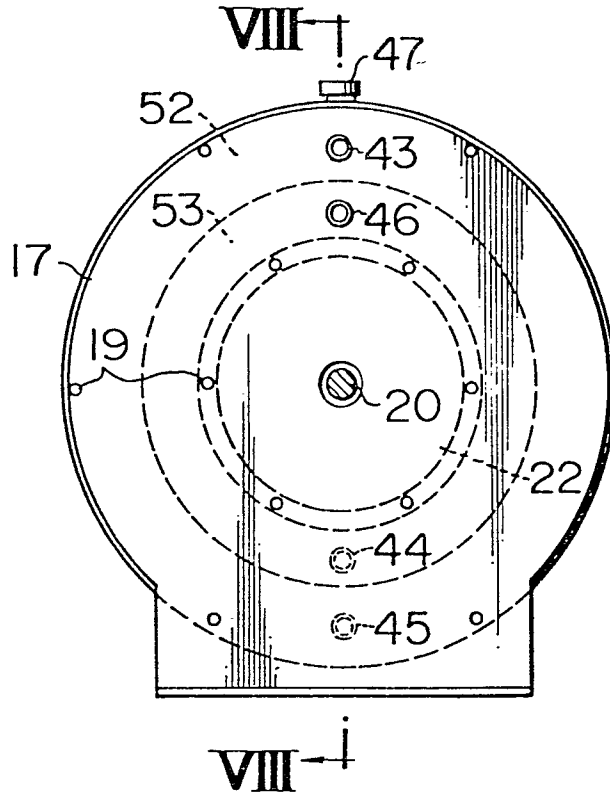
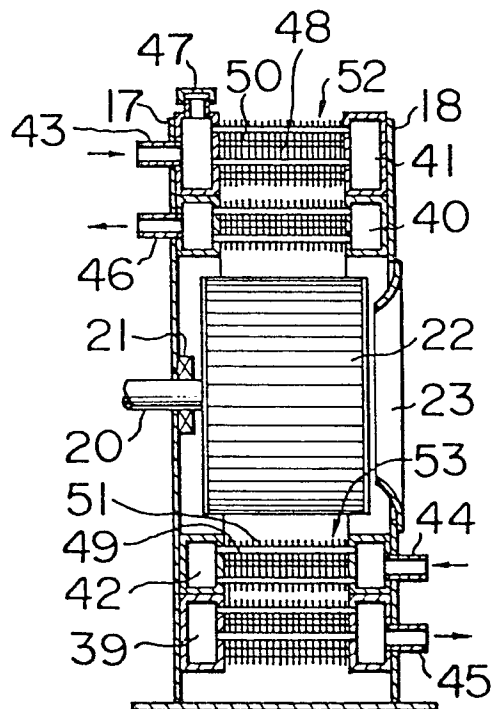
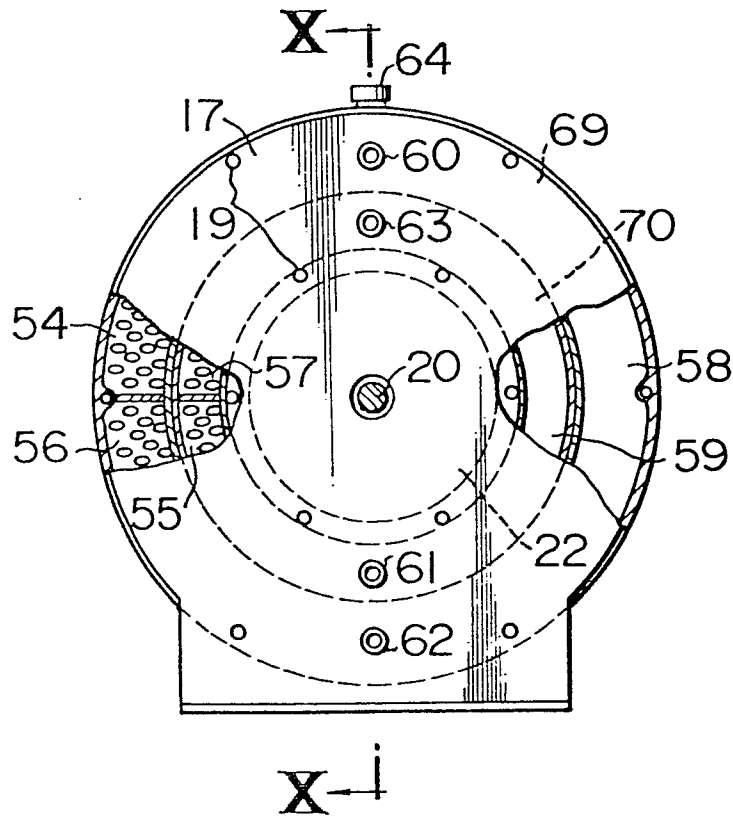

FIG. 8



5/5  
**FIG. 9**



**FIG. 10**

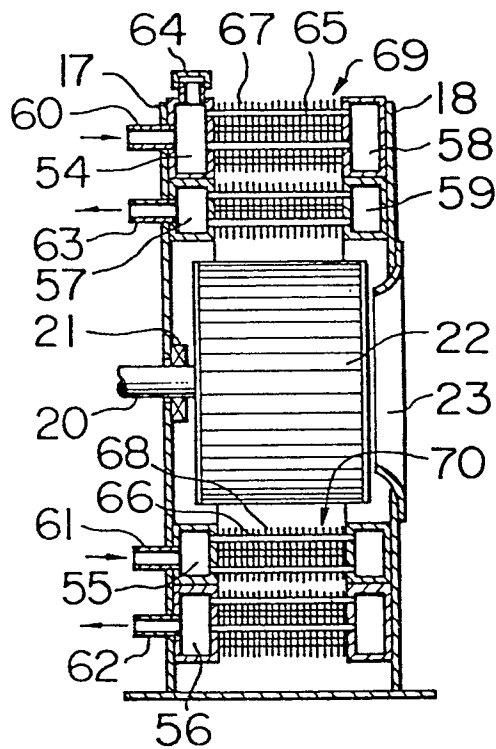



DOCUMENTS CONSIDERED TO BE RELEVANT		CLASSIFICATION OF THE APPLICATION (Int. Cl.)	
Category	Citation of document with indication, where appropriate, of relevant passages	Relevant to claim	
	<p><u>US - A - 2 171 817</u> (WAGNER)</p> <p>* Page 2, right-hand column, line 23 - page 3, left-hand column, line 74; figures 1,2,3,6 *</p> <p>--</p>	1,2,3	F 28 D 1/04
	<p><u>US - A - 2 260 594</u> (YOUNG)</p> <p>* Page 1, left-hand column, figures 1,2,3 *</p> <p>--</p>	1,2,3	TECHNICAL FIELDS SEARCHED (Int. Cl.)
	<p><u>US - A - 3 642 062</u> (EDMAIER)</p> <p>* Column 2, line 24 - column 3, line 32; figures 1,2 *</p> <p>--</p>	1,2,3	F 28 B F 28 D F 01 P
	<p><u>GB - A - 260 357</u> (FORGAN-POTTS)</p> <p>* Page 1, line 78 - page 2, line 7; figures 1,2 *</p> <p>--</p>	1,2,3	
	<p><u>DE - C - 255 444</u> (SCHMID)</p> <p>* The entire document *</p> <p>--</p>	1,4,5	CATEGORY OF CITED DOCUMENTS
	<p><u>US - A - 1 390 899</u> (FROELICH)</p> <p>* The entire document *</p> <p>--</p>	1,4,5,6	X: particularly relevant A: technological background O: non-written disclosure P: intermediate document T: theory or principle underlying the invention E: conflicting application D: document cited in the application L: citation for other reasons
	<p><u>FR - A - 557 583</u> (ARMAND)</p> <p>* Page 3, line 101 - page 4, line 64; figures 9-16 *</p> <p>--</p>	4,5,6	
A	<u>US - A - 3 800 866</u> (IRELAND)	1	& member of the same patent family, corresponding document
<p><input checked="" type="checkbox"/> The present search report has been drawn up for all claims</p>			
Place of search	Date of completion of the search	Examiner	
The Hague	26-06-1981	SCHOUFOUR	



DOCUMENTS CONSIDERED TO BE RELEVANT			CLASSIFICATION OF THE APPLICATION (Int. Cl. <sup>3</sup> )
Category	Citation of document with indication, where appropriate, of relevant passages	Relevant to claim	
A	<u>FR - A - 515 625</u> (DUBIEF)	1	
A	<u>DE - A - 2 718 966</u> (HARVESTER)	1	
	-----		
			TECHNICAL FIELDS SEARCHED (Int. Cl. <sup>3</sup> )