

EUROPEAN PATENT APPLICATION

Application number: **81102173.2**

Int. Cl.³: **F 24 F 5/00, E 06 B 7/12**

Date of filing: **23.03.81**

Priority: **25.03.80 US 133954**

Applicant: **ARDCO, INC., 12400 South Laramie Avenue, Chicago Illinois 60658 (US)**

Date of publication of application: **30.09.81**
Bulletin 81/39

Inventor: **Menke, Andrew G., 8600 West 145th Place, Orland Park Illinois 60462 (US)**

Designated Contracting States: **AT BE CH DE FR GB IT LI LU NL SE**

Representative: **Groening, Hans W., Dipl.-Ing., Siebertstrasse 4 Postfach 860 340, D-8000 München 86 (DE)**

Infrared reflective, visible light transparent windows.

The windows have at least two panes (12, 14) and an insulating space (30) therebetween. A surface of one pane is adjacent a warm environment, and a surface of another pane is adjacent a cool environment. At least two surfaces of the panes have coatings (50) which reflect at least about 50% of the incident infrared radiation.

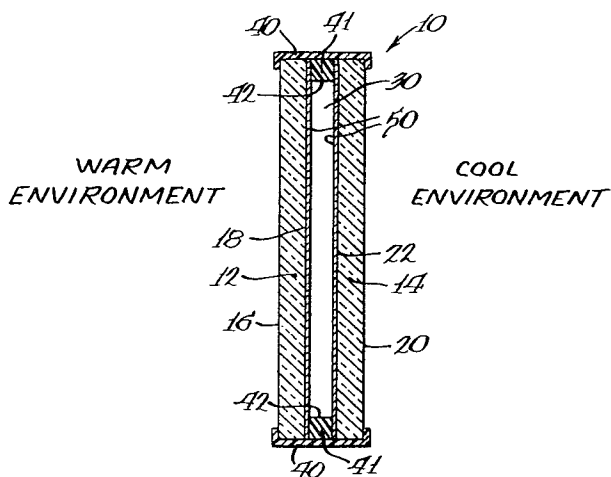

INFRARED REFLECTIVE, VISIBLE
LIGHT TRANSPARENT WINDOWS

DESCRIPTION

Technical Field

5 The present invention relates to windows which are transparent to visible light while being highly reflective of infrared radiation, and particularly to windows which are placed between warm and cool environments, such as in refrigerators.

10 Background Art

 Windows having at least two panes with an insulating space therebetween have been known and used for several years. Use of such windows allows large viewing areas with relatively small amounts of
15 heat flow from a warm environment to a cooler one than if a single pane window of the same area were used.

 Two pane plus insulating space windows have limited utility in refrigerator doors where the
20 environment on one side of the door's windows may be from about 10°C to about -40°C while the environment on the other side is about $15,6^{\circ}\text{C}$ or higher, and the warmer air has a relatively high humidity. These extremes of temperature and humidity are frequently
25 found in stores having self-service refrigerator sections, as for beverages, wherein it is desirable that the refrigerator door have a large transparent surface area. It is frequently found however, that the insulation provided by windows having two panes
30 and insulating space therebetween is insufficient to retard fogging of the door window due to moisture condensing from the warmer environment onto the window pane whose surface is adjacent thereto. Fogging is not only unattractive, but tends to reduce
35 sales in that potential customers find it difficult

-2-

to locate desired products, and consequently may not make those purchases.

Attempted solutions to the fogging problem found with two paned windows having an insulating space therebetween have included the use of 1) door windows having three panes with two insulating spaces therebetween; 2) windows having the pane adjacent to the warmer environment heated to raise that pane's dew point; and 3) windows having a heated pane and also a pane which reflects infrared radiation coming through the heated side pane back into and through that pane. This reflection is said to increase the pane's temperature and reduces undesirable heat transfer into the cooler environment. Each of these attempted solutions has economic draw backs.

First, as each pane is added to a window structure, the weight of the structure usually goes up as does the cost. Additionally, a three or more pane window structure is usually heavier and bulkier than is a window having fewer panes as there appears to be a minimal distance between panes of about 6,3 to 15,9 mm required to provide a proper insulating effect and this minimal spacing is normally used in two pane door windows.

Electrically heated refrigerator door windows are usually more costly to purchase and operate than are the above three pane door windows. These windows are generally more expensive to fabricate than the windows of the present invention or other non-electrically heated windows because of the extra wiring required to be both on the pane and in the remainder of the window and door, and the cost of the electricity required to heat them is a continuing overhead expense.

35

Summary of the Invention

An infrared reflective, visible light transparent window is disclosed. This window is comprised of at least a first pane, and a second pane. These two panes, a spacing means therebetween and a portion of the surface of a sealing means sealed around the marginal portions thereof define at least one insulating space therebetween. The first pane has its first surface adjacent a warm environment while the second pane has its first surface adjacent a cool environment. The second surfaces of these two panes face, and are preferably adjacent the insulating space. These windows additionally have at least two coated pane surfaces located between the surfaces adjacent the warm and cool environments, each of which coated surfaces reflects at least about 50% of infrared radiation incident thereon.

The presence of two coated surfaces each of which reflects at least about 50% of the incident infrared radiation is critical to the windows of this invention.

One advantage of the windows of the present invention is that they have anti-fogging properties which are comparable to heavier refrigerator windows having one more pane and one more insulating space.

Another advantage of the present invention is that electrically heated doors need not be employed to achieve a non-fogging refrigerator window.

Still another advantage of the instant windows is that they are less costly to make than are windows which have comparable anti-fogging properties.

Brief Description of the Drawings

In the accompanying drawings forming part of the specification:

Figure 1 is a cross-sectional view showing

an embodiment of this invention; and

Figure 2 is a cross-sectional view showing another embodiment of this invention.

Detailed Description of the Invention

5 While this invention is susceptible of
embodiment in many different forms, there are shown
in the drawings and will be herein described in
detail, preferred embodiments of the invention. It
should be understood, however, that the present
10 disclosure is to be considered as an exemplification
of the principles of the invention and is not
intended to limit the invention to the embodiments
illustrated.

 In the following description, two digit
15 numerals are used to refer to the embodiment illus-
trated in Figure 1 and to those elements of the
embodiment of Figure 2 which are the same or func-
tionally equivalent to those of Figure 1. Three
digit numerals in the 100 series are used to refer to
20 elements in the embodiment illustrated in Figure 2,
which are not present in the embodiment of Figure 1.

 According to the present invention,
infrared (heat) reflective, visible light transparent
windows which are particularly useful when placed
25 between warm and cool environments are disclosed.
These windows have anti-fogging properties when used
on refrigerator doors and are superior to windows
having the same number and dimensions of panes and
insulating spaces which do not so reflect heat. The
30 windows of this invention have anti-fogging prop-
erties which are comparable to refrigerator windows
having one pane and one insulating space more than do
the instant windows. These anti-fogging properties
are achieved by the incorporation into the window of
35 at least two heat (infrared) reflecting pane

-5-

surfaces, each of which will reflect at least about 50% of the infrared radiation incident thereon.

5 These reflective coatings appear to operate in at least two interrelated fashions to improve the operation of the windows. First, by reflecting heat emanating from the warm environment, back toward the warm environment, less heat reaches the inside of the refrigerator, and consequently, less power is consumed to cool the refrigerator's contents. This
10 reflected heat also acts to further heat the pane on the side adjacent the warm environment as some heat is absorbed by the pane each time the infrared radiation passes therethrough. Second, the heat reflective surface coatings on the panes tend to
15 diminish the thermal contact (or conduction) between the warm and cool environments.

A cross-sectional view of one embodiment of this invention is shown in Figure 1, and is designated generally therein by the numeral 10. The heat
20 (infrared) reflecting window 10 is comprised of at least two panes (shown in exaggerated thickness), a first pane 12 and a second pane 14, spaced apart in face-to-face relationship by a spacing means 41 therebetween and sealed around the marginal portions thereof with sealing means 40. The spacing means and
25 sealing means may be separate as shown in Figures 1 and 2 or may be integral, as is known in the art.

The panes 12 and 14 and a portion of the inner surface 42 of spacer 41 define an insulating space 30 therebetween. The insulating space 30 is
30 preferably filled with dry air or another dry gas such as nitrogen. The insulating space 30 may also be partially evacuated.

The first pane 12 has a first surface 16
35 adjacent a warm environment while the second pane 14

has a first surface 20 adjacent a cool environment. The second surface 18 of the first pane 12 faces the insulating space as does the second surface 22 of the second pane 14. Preferably, as is shown in Figure 1, the second surfaces of the first and second panes are also adjacent an insulating region, such as the insulating space 30.

The windows of this invention contain heat reflective coatings 50 (described hereinafter) on the surfaces of at least two of their panes. Each of these coated surfaces reflects at least about 50% of the infrared radiation which is incident thereon.

The heat reflecting coating 50 may be on any surface of the window pane. However, it is preferred that the heat reflecting coated surfaces 50 not be on the outermost surfaces of the windows, such as the first surfaces 16 and 20 of the first and second panes 12 and 14, respectively. Rather, it is preferred that the heat reflecting coatings 50 be between the outermost pane surfaces (e.g. surfaces 16 and 20) and on the interior of the window. The reasons for this preference stem mostly from a desire to assure the integrity of the surface coatings by placing the coatings on the interior of the window where they cannot be readily scratched, and also from the known fact that little improvement in the reduction of heat flow is obtained when a heat reflecting coating is on the outermost pane surface of the warm environment side of the window because of conductive heat loss.

The heat reflective coatings 50 (shown in exaggerated thickness) of the window illustrated in Figure 1 are shown in their preferred interior positions on the second surfaces 18 and 22 of the first and second panes 12 and 14, respectively .

-7-

Another embodiment of the present invention is illustrated in Figure 2 and generally designated therein by the numeral 170. This window contains a first pane 12, a second pane 14 and a third pane 160 and these panes and portions of the inner surfaces 42 of the surrounding gasket 40 define two insulating spaces 30 between the three panes.

The window of Figure 2 has three reflective coatings 50 which are disposed on the second surface 18 of the first pane 12 and on both surfaces 162 and 164 of the third pane 160. It is pointed out that the heat reflecting coated surfaces in a window having three panes need not be distributed as is shown in Figure 2 and may be distributed differently from those illustrated. However, at least two surfaces with heat (infrared) reflecting coatings are required per window of this invention. It is preferred that the heat reflecting coated surfaces be closest to the pane adjacent the warm environment (pane 12) so that as little heat as possible will build up in the pane near the cool environment. Thus, in preferred practice, the second surface 18 of the first pane 12 and at least the first surface 164 of the third pane 160 have reflective coatings. Keeping the reflective surfaces closest to the pane adjacent the warm environment, a third reflective coating is preferably placed on the second surface 162 of the pane 160, and this is illustrated in Figure 2. The required two heat reflecting coated surfaces for a window having three panes may be on the first and second surfaces 20 and 22, respectively, of the second pane 14, or on any three interior surfaces of the window.

The panes of the windows of this invention are preferably made of glass, and this glass is

preferably heat strengthened or tempered for reasons of safety. The panes may also be comprised in whole or in part of plastics such as polycarbonate or polymethyl methacrylate, as is known in the art. In
5 preferred practice, the panes are single thicknesses of glass such as plate glass or so-called "float" glass.

A "pane", as that term is used herein, may also be comprised of one or more lights of glass with
10 or without an intermediate plastic layer, such as polyvinylbutyral, which lights may or may not be adhered together to form a unitary structure. An example of such a unitary structure is the so-called
15 "safety" glass frequently used in automobile windshields and made from two sheets of glass having a plastic adhesive such as polyvinylbutyral therebetween.

The windows of this invention are preferably transparent or substantially transparent to
20 visible light. The terms "transparent" and "substantially transparent" are used herein in the sense that a window of an automobile or a house are transparent, that is that while some visible light is absorbed and/or reflected by the window, one looking through
25 such windows would hardly notice that visible light transmission is somewhat reduced compared to transmission through air.

Heat or infrared reflective coatings are broadly old in the art. Thus, it is known that
30 metallic coatings such as copper and gold, and metallic oxide coatings such as tin oxide and the like will reflect infrared radiation while being themselves transparent to visible light or substantially so. While the heat reflecting properties of
35 these coatings is broadly known, it was not

heretofore known or suggested that utilization of windows with at least two surfaces having coatings which reflect at least about 50% of infrared radiation incident thereon would produce windows with
5 non-fogging properties similar to windows having an additional pane and insulating space.

While several heat reflecting coatings are useful herein, coatings made from tin oxide are preferred. This preference stems from cost, ease of
10 manipulation, visible light transmission and infrared reflecting considerations. Tin oxide coatings such as those used herein are themselves old insofar as their chemical constituents and methods of applica-
tion are concerned.

15 In addition to the tin itself, minor amounts of other metal ions such as indium or antimony may be incorporated into the coating compositions and therefore the coatings. Incorporation of these additional metal ions further "dopes"
20 the coatings, increases their electrical conductivity (lowers the resistance) and thereby improves the infrared reflectance, as is known. It is noted that the tin oxide coatings used herein and known in the art are not pure tin oxide, but are themselves
25 "doped" with small amounts of tin which may be in various oxidation states.

The preferred tin oxide heat reflective coating is at least about 1200 Å (Angstrom) thick, and more preferably about 2500-3000 Å thick.
30 Additionally, these coatings have resistances which are preferably at most about 90 Ω /square and more preferably about 50 Ω /square, or less. Coatings having the above thicknesses and resistances have been previously prepared. However, it was neither
35 known nor suggested that such coatings would be

useful by themselves to stop or reduce fogging in windows such as those useful in refrigerator doors as described herein.

5 It is found that coating layers which are homogeneously applied, and have a thickness of about 1200 Å or a resistance of about 90 Ω /square will have infrared (2 -15 micron region) reflectances which average at least about 50% throughout this infrared spectral range. Average infrared reflect-
10 ances for coatings having the more preferred resistance of about 50 Ω / square and the preferred thickness of about 2500-3000 Å may be up to about 60-70%.

15 The heat reflective coating compositions are preferably applied to the panes by spraying an appropriate solution thereon. In preferred practice, the panes are glass, and they are sprayed with the coating composition when the glass is at a temperature near about 427-677° C. This spraying normally
20 takes place after the glass has emerged from a furnace, and the techniques are known in the art.

To demonstrate the effectiveness of the windows of this invention, two refrigerator doors were constructed using materials of substantially
25 identical dimensions. The windows of these doors had the general construction as is shown in Figure 1, except that one window had no infrared reflective coating while the other was prepared as per this invention and had two panes coated as is shown in
30 Figure 1. The doors were both attached to a single refrigerator. At a cool environment temperature (inside the refrigerator) of 1,11° C, a warm environment (room) temperature of 25,6° C with 65% relative humidity, the door window prepared according to this
35 invention had no fogging or visible condensation,

-11-

while the door window prepared from panes which were not coated with a heat reflecting layer fogged. For comparison, a three pane door window having two insulated air spaces would fog at a relative humidity of about 64% with a refrigerator temperature of $1,11^{\circ}\text{C}$ and a room temperature of $25,6^{\circ}\text{C}$.

10

15

20

25

30

35

1 What is claimed is:

- 5 1. A heat reflective, visible light transparent window (10,170) for placement between warm and cool environments comprising at least a first pane (12), a second pane (14), means (41) for spacing apart said panes (12,14) therebetween and means (40) for sealing sealed around the marginal portions thereof defining at least one insulating space (30), said first pane 10 (12) having a first surface (16) adjacent to said warm environment and said second pane (14) having a first surface (20) adjacent said cool environment, said first and second panes (12,14) each having second surfaces (18,22) facing said insulating space (3d), and said window (10,170) having at least 15 two pane surfaces coated with a reflective coating (50), each of said coated surfaces reflecting at least about 50 % of infrared radiation incident thereon, said coated surfaces being located between said surfaces (16,20) adjacent said warm and cool environments.
- 25 2. The window according to claim 1 wherein said surfaces each reflecting at least about 50 % of incident infrared light are said second surfaces (18,22) of said first and second panes (12,14), and said surfaces are adjacent said insulating space (30).
- 30 3. The window according to claim 1 comprising a third pane (160) located between and spaced apart from said first and second panes (12,14), the marginal portions of said third pane (160) being sealed by said sealing means (40), said third pane (160) 35 having at least one of said surfaces reflecting about 50 % of infrared radiation incident thereon.

- 1 4. A heat reflective, visible light transparent window
(10, 170) for placement between warm and cool en-
vironments comprising
at least a first pane (12), a second pane (14),
5 means (41) for spacing apart said panes (12,14) there-
between, and means (40) for sealing sealed around the
marginal portions thereof defining at least one in-
sulating space (30), said first pane (12) having a
first surface (16) adjacent said warm environment
10 and a second surface (18) adjacent said insulating
space (30), said second pane (14) having a first
surface (20) adjacent said cool environment and a
second surface (22) adjacent said insulating
15 space (30), said second surface (18,22) of said first
and second panes (12,14) being coated with an in-
frared reflective coating (50), each of said coated
surfaces reflecting at least about 50 % of the in-
frared light incident thereupon.
- 20 5. The window according to claim 4 wherein said in-
frared reflective coating (50) is comprised of tin
oxide forming a layer at least about 1200 Å thick.
- 25 6. The window according to claim 5 wherein said in-
frared reflective coating (50) is comprised of tin
oxide forming a layer about 2500-3000 Å thick.
- 30 7. The window accordint to claim 4 wherein said in-
frared light reflective coating (50) is comprised
of tin oxide having a resistance of at most about
90 Ω /square.
- 35 8. The window according to claim 7 wherein said in-
frared reflective coating (50) is comprised of tin
oxide having a resistance of about 50 Ω /square.

1 9. A heat reflective, visible light transparent re-
frigerator door window (10,170) for placement be-
tween warm and cool environments comprising
5 a first pane (12), a second pane (14), means (41)
for spacing apart said panes (12,14) therebetween,
and means (40) for sealing sealed around the marginal
portions thereof defining an insulating space (30),
said first pane (12) having a first surface (16)
10 adjacent said warm environment and a second surface
(18) adjacent said insulating space (30),
said second pane (14) having a first surface (20)
adjacent said cool environment and a second surface
(22) adjacent said insulating space (30),
15 said second surfaces (18,22) of said first and second
panes (12,14) each having an infrared reflective
coating (50) comprising tin oxide forming a layer
about 2500-3000 Å thick and having a resistance of
at least about 50 Ω /square.

20

25

30

35



Fig. 1.

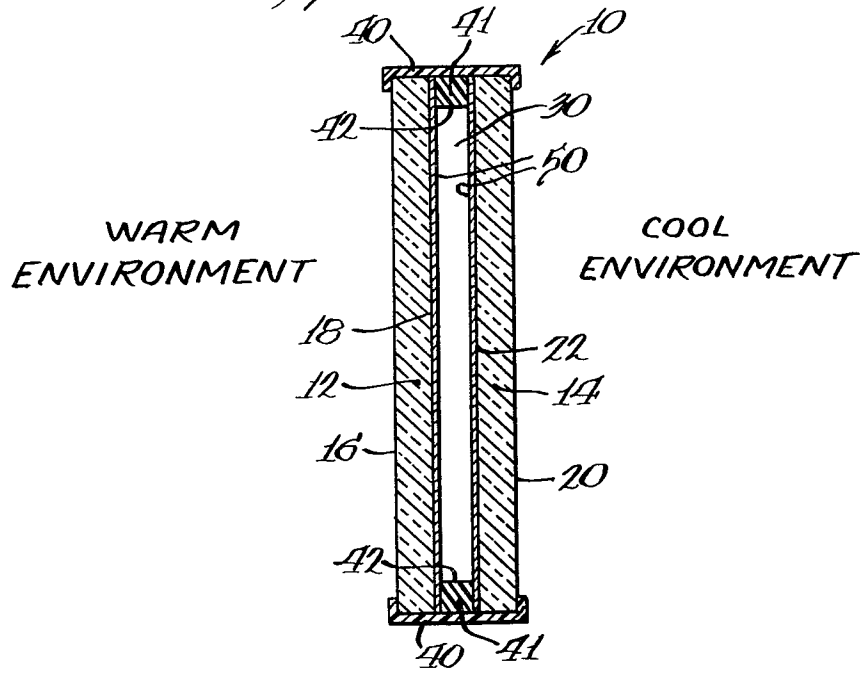

Fig. 2.

