

 **EUROPEAN PATENT APPLICATION**

 Application number: **81301319.0**

 Int. Cl.³: **B 41 J 3/04**

 Date of filing: **26.03.81**

 Priority: **26.03.80 GB 8010103**

 Applicant: **CAMBRIDGE CONSULTANTS LIMITED, Science Park Milton Road, Cambridge CB4 4DW (GB)**

 Date of publication of application: **30.09.81 Bulletin 81/39**

 Inventor: **Lewis, John Didwith, 26 Girton Road, Cambridge (GB)**
 Inventor: **Keeling, Michael Richard, 15 Rampton Road, Willingham Cambridge (GB)**
 Inventor: **Bowen, David Richard, 14 Otter Close, Bar Hill, Cambridge (GB)**

 Designated Contracting States: **BE DE FR GB NL SE**

 Representative: **Coleman, Stanley et al, MATHYS & SQUIRE 10 Fleet Street, London EC4Y 1AY (GB)**

 **Liquid jet printing apparatus.**

 An ink jet array printer (1) has at least one row of printing guns (3). The guns deposit drops (9) charged for printing in line sections (23' 23'' 23''' 23''''') which together form a transverse printing line (23). Control means with detectors (25) are provided which control the printed drop placement positions in the direction transversely to the direction of relative motion of the printer (1) and the printing surface (13).

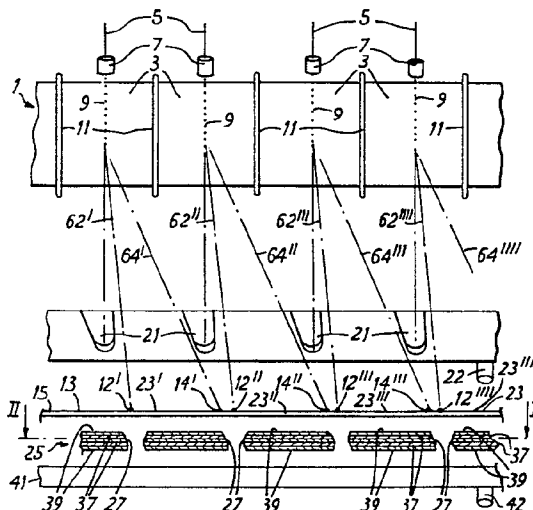

EP 0 036 789 A1

This invention relates to ink jet printers and more particularly to ink jet array printers. The term "ink" as used hereinafter is intended to embrace other printing liquids, such as liquid dyes, as well as liquid ink.

Ink jet array printers employing one or more rows of ink jet printing guns and serving as pattern printers are described, for example, in United Kingdom specifications Nos. 1354890 and 1432366 though when employing one row only of ink jet printing guns, they may be used for character or facsimile printing.

The printing apparatus described in the specifications referred to is adapted to print by depositing small drops of ink in accordance with printing information on a surface to be printed during movement relatively to the apparatus of the surface, and comprises one or more rows of ink jet printing guns, each gun having means for supplying printing ink under pressure to an orifice, means for forming regularly spaced drops in the ink stream issuing from the orifice, charge electrode means for charging the drops, means for applying to the charge electrode means, under the control of the printing information, a periodic voltage waveform whose period is sufficient to span the formation of a series, hereinafter referred to as a "raster" of consecutively formed drops, drop deflection means for providing a substantially constant electrostatic field

through which the drops pass towards the printing surface thereby to deflect electrically charged drops to an extent dependant upon the charge levels on the drops and drop intercepting means for collecting drops other than those drops charged for printing on the printing surface, the drops charged for printing in the printing guns during each period of the voltage waveform being deposited in respective line sections formed by contiguous drops which sections together present a printed line transversely of the direction of relative movement, the printed lines being formed in contiguity successively at the frequency of the voltage waveform applied to the charge electrode means.

It is an object of the present invention to provide an improved form of ink jet array printer of the kind set forth.

The present invention consists in an ink jet array printer which is characterised in that control means are provided which control the printed drop placement positions in the direction transverse to ^{the direction of} relative motion of the print surface and the printer.

Preferably, the control means are adapted to derive correction voltages for drop placement errors at the ends of the line section formed by printed drops of each printing gun.

Suitably, the control means include detectors and sense in sequence for each printing gun at a selected level relatively to the printing surface, the extent of departure in the direction transverse to the direction of relative motion of the printer and print surface from a correct position of the higher deflected jets and of each corresponding lower deflected jets.

In one form of the invention the printer is a sheet fed printer and the detectors are located below the level of the printing surface, so that drop placement error correction tests can take place between printing of sheets.

In another form of the invention the printer is a web fed printer and the detectors are located above the level of the printing surface and drop intercepting gutters and that transverse deflection error testing takes place in intervals between printing.

The control means of the invention advantageously include means for controlling ink supply pressure to the printing guns. Suitably, the ink supply pressure is controlled by controlling the outlet pressure of an ink supply pump.

The invention will now be described by way of example, with reference to the accompanying drawings, in which:-

Figure 1 is a somewhat diagrammatic fragmentary elevation to an enlarged scale and partly in section, of a sheet fed, ink jet array printer according to the invention,

Figure 2 is a diagrammatic sectional plan view taken approximately at the level II - II of Figure 1 illustrating certain details only of the printer of Figure 1,

Figure 3 is a view similar to Figure 1 showing a web fed ink jet array printer according to the invention,

Figure 4 is a somewhat diagrammatic plan view taken approximately at the level IV - IV of Figure 3 illustrating certain details only of the printer of Figure 3.

Figure 5 is a block diagram of electronic circuitry controlling the operation of the printers of Figures 1 to 4.

In the drawings like parts have been accorded the same reference numerals.

Referring first to Figures 1 and 2, an ink jet array printer 1 comprises a row of printing guns 3 which each have means for supplying ink under pressure to an orifice

(not shown) from which the ink issues as a downwardly directed stream 5 which at the level of charge electrodes 7 breaks up into regularly spaced drops 9. The charge electrodes 7 are supplied under the control of printing information with a periodic waveform comprising one or more sequences of different voltage levels. The period of the waveform spans the formation of a series or raster of drops charging the drops as determined by the voltage levels prevailing at the charge electrodes 7 as the drops separate in the streams 5. The charged drops 9 descend between a pair of deflection plates 11 where they are subjected to a constant transverse electrostatic field in which the drops are deflected to an extent dependent upon the levels of charge which they carry. The drops charged for printing are deposited on a printing surface 13 which in the case of the printer of Figures 1 and 2 is that of a sheet 15 of a sheet fed machine, whilst, in the case of the printer of Figures 3 and 4, the surface 13 is that of a web 17 of a web fed machine. The arrow 19 indicates the direction of motion of the printing surface 13 through the printer.

Between the deflection plates 11 and the printing surface 13 is located a transversely extending row of drop interception gutters 21 in which are collected unprinted drops. Unprinted drops may be uncharged drops which arise on start up or shut down of the printer. These are deposited in the gutter 21 immediately below the charge

electrode 7 through which they pass. Drops in the printing rasters which are not intended for printing are also given a predetermined low charge which deflects them to the same gutter 21 below the charge electrode. The drops collected in the gutters 21 are recirculated through a pipe 22 which extends from the body of the gutters.

The printing raster drops which are charged for printing are deposited at print positions in line sections 23' 23'' 23''' and 23'''' of a printed line 23 (in the plane of Figure 1 and Figure 5), there being one such line printed for each period of the voltage waveform applied to the charge electrodes 7. The drops charged for printing form spots on the printing surface and spots in adjacent print positions in the line sections and the print lines are contiguous and need to be printed to within a tolerance of, typically, one quarter of a spot pitch in order to present acceptable printing quality.

In the printing guns 3, drops 9 which are selected for printing in any raster are deposited in line sections between extreme locations 12' and 14', 12'' and 14'', 12''' and 14''' etc., on the printing surface. A typical raster used is described in our co-pending application No. . Also described in this co-pending application are methods of allowing for pattern related errors caused by drop interaction.

A variety of factors affects the accuracy of drop placement both in and transverse to the direction of printing surface movement through the printer. The control of drop placement position in the direction of printing surface motion is the subject of our co-pending application No.

Here concern is confined to the control of drop placement position in a direction transverse to the direction of motion of the printing surface.

Apart from inaccuracies of drop placement caused by drop interaction, the printing accuracy of the drops printed in each line section between the locations 12' and 14', 12'' and 14'' etc., also depends on the accuracy of a variety of other factors. If printing accuracy were to be maintained on an open loop basis, i.e. without detection and feed back of errors to effect correction, a high level of manufacturing accuracy would be required. The printing gun parameters that would be significant would include transverse alignment of jets at start up, concentricity of charge electrode and deflector plate spacing. Other parameters such as the ink jet alignment and velocity or the deflection voltage between the deflector plates ll would need to be maintained during printer operation. Such accuracy and control would be costly to achieve and for this reason closed loop control of each printing gun jet at each end of the relevant line section is employed. It will be realised that if the

printed drops at the adjacent ends of line sections are not accurately placed on the printing surface, the printed pattern is apt to have an irregular appearance of light and dark striations extending in the direction of motion between line sections.

Apart from transverse misalignment of nozzles most of the transverse drop placement errors appear as a change in the amplitude of drop deflection. Were the system to be linear, the determination of the voltages required to deflect a drop stream to the extremities of the corresponding line section would provide in each case a measure of the ratio of charging voltage to deflection which measure could be linearly proportioned to provide a correction for all the drop charging voltages of the raster voltage waveform. Also the difference of the two measures could provide an offset which could be added to each raster charging voltage to remove the effect of transverse misalignment of the jet 5. Fortunately, for small errors, the approximation to a linear system works sufficiently well particularly since the drop placement errors are greatest away from the measured points and the measured points can be printed at the maximum and minimum deflected points where the printed line sections of adjacent printing guns 3 meet.

In the sheet fed printer of Figures 1 and 2, the deflection errors are sensed at the ends 12' and 14', 12'' and 14'', 12''' and 14''' of the line sections by detector 25 which comprises a five layered sandwich of which the middle layer 27 consists of two rows of induced charge detector electrodes 29, 31, row 29 of which comprises alternating electrodes P and Q whilst row 31 comprises alternating electrodes R and S. The layer 27 is located at a level where in the absence of the sheet 15, drop 12' and 14', 12'' and 14'' etc. would coincide. The electrodes P are spaced from electrodes Q by constant spacings and are spaced from the electrodes R by a gap 33 which is inclined with respect to the direction transverse to the direction of travel of the print surface 13. Similarly the electrodes Q and S are spaced by a gap 35 equal in magnitude in the direction of travel of the surface 13 to the gap 33 and inclined to the direction transverse to the direction of travel by the same angle, the gaps 33 and 35 however being inclined in opposite senses to the direction of travel. The angling of the gaps 33 and 35 of the detector electrodes P, R and Q, S is required for detecting alignment errors in the direction 19 of print surface travel as described in co-pending application No. For the tests to be described hereinafter the electrode pairs P, R and Q, S are effectively connected and the jet locations are measured relative to the centre line of the gap between the electrode pairs.

On opposite sides of the electrodes P, Q, R and S are respective insulating layers 37 which on the sides thereof remote from the electrodes P, Q, R and S are covered by respective earthed conductive layers 39 which serve to screen the electrodes P, Q, R and S from electrical noise. Below the detectors 25 is located a drop collection gutter 41 which collects for recirculation via a pipe 42 drops which during the jet alignment tests pass, as hereinafter described, between the pairs P, R and Q, S of detector electrodes.

Referring now to Figure 5, during printing, pattern data indicating print/no print information is fed from pattern store 44 to multiline stores 43', 43'' etc. of each printing gun 3 into the single bit locations specified by the Write Address Generator 45 fed by multiplexer 47. The Write Address Generator 45 serves the dual purpose of re-arranging the pattern data into groups so that the data is stored in approximate drop charging order and it also allows a variable delay to be introduced in the printing of the pattern by varying the separation between write addresses and read addresses, as generated by the Read Address Generator 77. Data from the multiline stores is fed to print voltage generators 49', 49'', 49''' in which the voltages to be applied to the respective electrodes charge /formed in the different printing guns are generated.

These voltages are fed to the appropriate digital to analogue converters 51', 51'', 51''' which apply the drop charging voltages to the corresponding charge electrodes 7.

The deflection jets in the printing guns of the sheet fed printer are designated 62', 62'', 62''' etc. in the case of the lower deflected jets and 64', 64'' 64''' etc. in the case of the higher deflected jets. The jets 64', 64'' etc. are each monitored under the control of Controller 53 during periods between printing sheets by generating a brief burst of drops which are charged by a voltage waveform stored in digital form in a memory in Test Pattern Generator 55. This voltage waveform, applied to the charge electrode 7 concerned directs the burst of drops in the path of the relevant jet 14', 14'' etc. and through the region between connected pairs of detector electrodes P, R and Q, S before the drops are collected in the gutter 41. The induced voltage signals from P, R and Q, S are compared in signal comparator 54. If a larger signal is induced by the drops on the electrode pair P, R than on the electrode pair Q, S, then the Controller 53 adjusts the Test Pattern Generator 55 and the test is repeated with a slightly higher voltage applied to the charge electrode 7 concerned from the Test Pattern Generator. If the voltage induced on P, R is still greater than that on Q, S, the test is again repeated with a higher voltage supplied to the electrode 7 from Generator 55. As soon as

the deflection on Q, S exceeds that on P, R, the deflection of the jet has passed through the null point i.e. the point where the induced voltages on P, R and Q, S are equal, corresponding to the location of the centre line between the electrode pairs. A representation of the voltage value required to deflect the jet through the null point is stored by the controller in the memory 56.

If the initial induced voltage on P, R and Q, S was less than that on the Controller 53 a signal from the comparator 54 would cause a voltage pattern of lower voltage to be supplied by the Test Pattern Generator 55 to the electrode 7. If the induced voltage on P, R remained lower than that on Q, S again the Test Pattern Generator would be caused to supply a still lower voltage waveform to the electrode 7 and the procedure would continue in steps until the null point was passed and a voltage indicating that event would be stored in the memory 56.

The test is carried out on each the jets 14', 14'',
higher transverse
14''', 14'''' to the end that a series of/correction
voltages is stored in the memory which is updated at
suitable intervals and at times between printing of sheets.

The lower deflected jets 64', 64'', 64''' etc. are also monitored adopting the same procedure as described for the higher deflected jets and a set of/correction
lower transverse
voltages appropriate to the lower deflection jets is thus also stored in the memory and updated/^{together}with the voltage
corrections of the corresponding higher deflected jets in the respective printing guns 3.

The stored voltage corrections for respective ends of the corresponding line section are compared each with a reference value which is the preferred value for the deflected raster and the differences sometimes referred to as "offsets" are linearly proportioned and applied to each voltage in the print voltage generator / In this way a continual check is kept on the evenness of spacing of drops printed in the line section and between line sections of adjacent printing guns 3. The check routine is typically carried out every few minutes in a sheet fed array printer incorporating fifty six guns spanning a width 200mm of printing surface 13.

Referring now to Figures 3 and 4 in which a web fed printer is illustrated, the detectors 25 are again made of a central detector electrodes 71 designated X and Y between layers 73 of insulation, the latter being covered by conductive earthed layers 75 which screen the electrodes 71 from electrical noise. Opposite the electrodes 71 and spaced therefrom by a gap 74 is an earthed block 76. The gutters 21 lie vertically below the gap 74, but above the web 17, so that the test drops are collected.

The detectors 25 are used both for deflection correction in the direction of travel of the web 17, as described in co-pending application No. and for correction in a direction transversely to the direction of motion of the web 17 which is the present concern. Testing to evaluate the magnitude of this latter

correction takes place during intervals between printing. Jets 77', 77'', 77''', 77'''' in the printing gun are employed for the test to the most deflected jets which take place on one gun at a time. The jets 77' 77'' 77''' and 77'''' are directed to the gutter 21 of the respective adjacent printing guns, the gutters being large enough to permit a small range of jet deflection about the detector. Charged drops in their paths each induce voltages on a pair of the electrodes X and Y and the deflection which corresponds to a null voltage between the electrodes is located. This higher transverse correction voltage is measured successively for each printing gun 3 and stored as a digital voltage in the memory 56 by use of the Test Pattern Generator procedure described in relation to Figures 1 and 2.

The correction voltages for the least deflected jets are derived in either of two ways. At the beginning of a period of printing, for example, at the commencement of daily operation, the alignment of the jets 5 is evaluated by charging a burst of drops under the control of a voltage waveform supplied from the Test Pattern Generator and sending them between the plates 11 with the electrostatic field thereof switched off. Voltages are induced on the electrodes X and Y which are sensed and measured and their difference together with their sum as measured in co-pending application No. provides an indication of the displacement of the jet

from its nominal position. The locations corresponding to the voltages so derived for each gun are converted into lower transverse correction voltages corresponding to the jet alignment and are used for the whole of the printing period, e.g. the day, between tests.

The second way of deriving these voltages is to arrange that the gutters are extended to lie very close to the paths of drops printed in line section positions 12' 12'' and 12''' etc. of the least deflected drops. Typically a deflection voltage of 80 volts is needed to charge these drops, and it is arranged that the drops having a slightly lower voltage e.g. 60 volts are caught by the gutter. The gap between the detector electrodes X and Y is placed adjacent the path of these drops to one side of the axis through the charge electrodes in which uncharged drops pass. The deflection voltages for the test drops which give a null voltage between the electrodes X and Y are now obtained. The voltages representing this displacement for each gun are measured and stored in the memory 56 and used as lower transverse correction voltages as before.

The routine described both for the sheet fed and web fed machine for setting and maintaining the contents of the memory 56 which via the controller 53 applies the required correction voltages for printed drops at the ends of the line sections 23', 23'', 23''', 23'''' and linearly interpolated correction voltages for charged drops to be deposited at drop placement positions intermediate the ends of the line sections, serves to maintain printing accuracy during short term operation of the printer. It enables each raster in the printer to settle down rapidly and accurately to a 'print ready' status immediately following start-up and to maintain that status constantly for immediate use. However, the range of adjustment of the correction voltages is limited, because if the required corrections become too large then the non-linearity of the system becomes apparent in errors caused by drop interaction.

The routine therefore accommodates differences between the guns; deflector plate spacing, small differences in nozzle sizes or alignment, small differences in charge electrode gaps or charge electrode signal amplitude. It also accommodates small changes i.e. short term variations of in the printing gun whilst operating / such parameters as drop mass or velocity.

Temperature changes in the printer, or changes in the solvent concentration can result in changes in the viscosity in the printing ink. Such changes can be considerable, resulting in variations of a factor of two or more and it has been found necessary to use an ink supply pump(57, see Figure 5) whose output pressure is variable. A property of the ink jets such as the jet velocity / ^{or deflection} can be maintained constant by altering the output pressure of the pump to compensate for viscosity changes. /a pump output pressure control reduces the range of upper and lower voltage levels needed to keep drops deposited in the line section of each printing gun; however the closed loop system controlling the upper and lower extreme voltage is still needed /to maintain the accuracy within each printing gun in the printer as control of the pump affects all the printing guns likewise.

In a further procedure of the invention the upper and lower deflection tests are carried out on the adjacent printing gun as already described.

The results are stored in the memory 56. The controller 53 subtracts the representation of the voltage found on the low deflection test, from that found on the high deflection test, thus removing the effect of the transverse error due to nozzle misalignment.

The controller in the printer also includes an Arithmetic Unit 58 in which the results of the subtraction for each printing gun are averaged and the resulting average value is maintained equal to a pre-set value. If the average has for example become higher than the set value, it indicates that the charge voltages have increased to compensate a higher ink drop velocity resulting ostensibly from a reduced ink viscosity. As a consequence the pump delivery pressure must be reduced thereby to reduce the ink drop velocity. Similarly, if the average voltage has become lower than the set value, indicating lower ink drop velocity and higher viscosity then the pump delivery pressure is increased to correct the condition. A pump drive circuit, 59, incorporating a digital feed-back circuit adjusting the pump pressure is preferably used, and the printer in one arrangement has time to settle down after each step adjusting the pump, to reset the higher and lower deflection correction voltages to maintain accurate printing before being used for printing again. Alternatively the pressure steps by which the pump is adjusted are made small enough for the accuracy to be maintained.

The average value is used to control the pump because in an array printer it is more representative of the condition in the ink supply manifold of the printing

guns than the value of any one jet. However, each deflection is monitored and if it tends to rise above a maximum value - relative to the preset value - indicative of a low speed jet which may possibly be due to an incipient blocked nozzle - the printer is stopped and maintenance is indicated.

If a pump delivers ink at a common pressure to several printing gun manifolds, the average value (derived by the arithmetic unit 58) of the charge voltage may alternatively be used to control a restriction in the entry pipe to each manifold, which similarly controls the manifold supply pressure.

1. An ink jet array printer adapted to print by depositing small drops of ink in accordance with printing information on a surface to be printed during movement relatively to the apparatus of the surface, comprising one or more rows of ink jet printing guns, each gun having means for supplying printing ink under pressure to an orifice, means for forming regularly spaced drops in the ink stream issuing from the orifice, charge electrode means for charging the drops, means for applying to the charge electrode means, under the control of the printing information, a periodic voltage waveform whose period is sufficient to span the formation of a "raster" of consecutively formed drops, drop deflection means for providing a substantially constant electrostatic field through which the drops pass towards the printing surface thereby to deflect electrically charged drops to an extent dependant upon the charge levels on the drops and drop intercepting means for collecting drops other than those drops charged for printing on the printing surface, the drops charged for printing in the printing guns during each period of the voltage waveform being deposited in respective line sections formed by contiguous drops which sections together present a printed line transversely of the direction of relative movement, the printed lines being formed in contiguity successively at the frequency of the voltage waveform applied to the charge electrode

means, characterised in that control means (25, 54, 53, 55, 56) are provided which control the printed drop placement positions in the direction transversely to the direction of relative motion of the printing surface and the printer.

2. A printer as claimed in claim 1, characterised in that the control means (25, 54, 53, 55, 56) are adapted to derive correction voltages for drop placement errors at the ends of the line section formed by printed drops of each printing gun.

3. A printer as claimed in claim 2, characterised in that the control means (25, 54, 53, 55, 56) are adapted to derive correction voltages for drop placement errors at intermediate points in the line section of each printing gun by linearly evaluating such correction voltages in relation to the correction voltages derived for the drop placement errors at the ends of the line section.

4. A printer as claimed in claim 3, characterised in that the control means include detectors (25) and sense in sequence for each printing gun at a selected level relatively to the printing surface, the extent of departure in the direction transverse to the direction of relative motion of the printer (1) and print surface (13) from a correct position of the higher deflected jets (64' 64'' 64''' 64'''' 77' 77'' 77''' 77''''') and of each corresponding lower deflected jets.

5. A printer as claimed in claim 4 and in which the printer is a sheet fed printer, characterised in that the detectors (25) are located below the level/ ^{of the printing surface} so that drop placement error correction tests can take place between printing of sheets.

6. A printer as claimed in claim 5, characterised in that the detectors (25) are located in a plane where the most and least deflected drops of adjacent printing guns coincide if correctly directed.

7. A printer as claimed in claim 6, characterised in that ^{include detectors (25) and} the control means /are adapted to measure the extent of each error by comparing voltages induced by the most and least deflected jets of each printing gun on respective detector electrode pairs (PR, QS) and in that means (55) establish the signal voltage required to move, as the case may be, the higher or the lower deflected jet to a point of zero induced voltage difference between the detector electrode pairs.

8. A printer as claimed ^{any one of} in/claims ^{1 to 4} /and in which the printer is a web fed printer, characterised in that the detectors (25) are located above the level of the printing surface (13) and drop intercepting gutter (21) and that transverse deflection error testing takes place in intervals between printing.

9. A printer as claimed in any preceding claim, characterised in that the control means include means (58, 59) for controlling ink supply pressure to the printing guns.
10. A printer as claimed in claim 9 characterised in that the control means (58 and 59) are adapted to control the outlet pressure of an ink supply pump (57).
11. A printer as claimed in claim 9 or claim 10, characterised in that control means include a controller (53) which is adapted to subtract the lower from the higher voltage corrections stored in a memory 56 and an arithmetic unit is provided which forms an average value for all printing guns/^{of}said subtracted values.
12. A printer as claimed in claim 11, characterised in that the controller (53) compares the average value with a set value and causes the ink supply pressure to be adjusted in dependence upon the difference of the compared values.

FIG.1

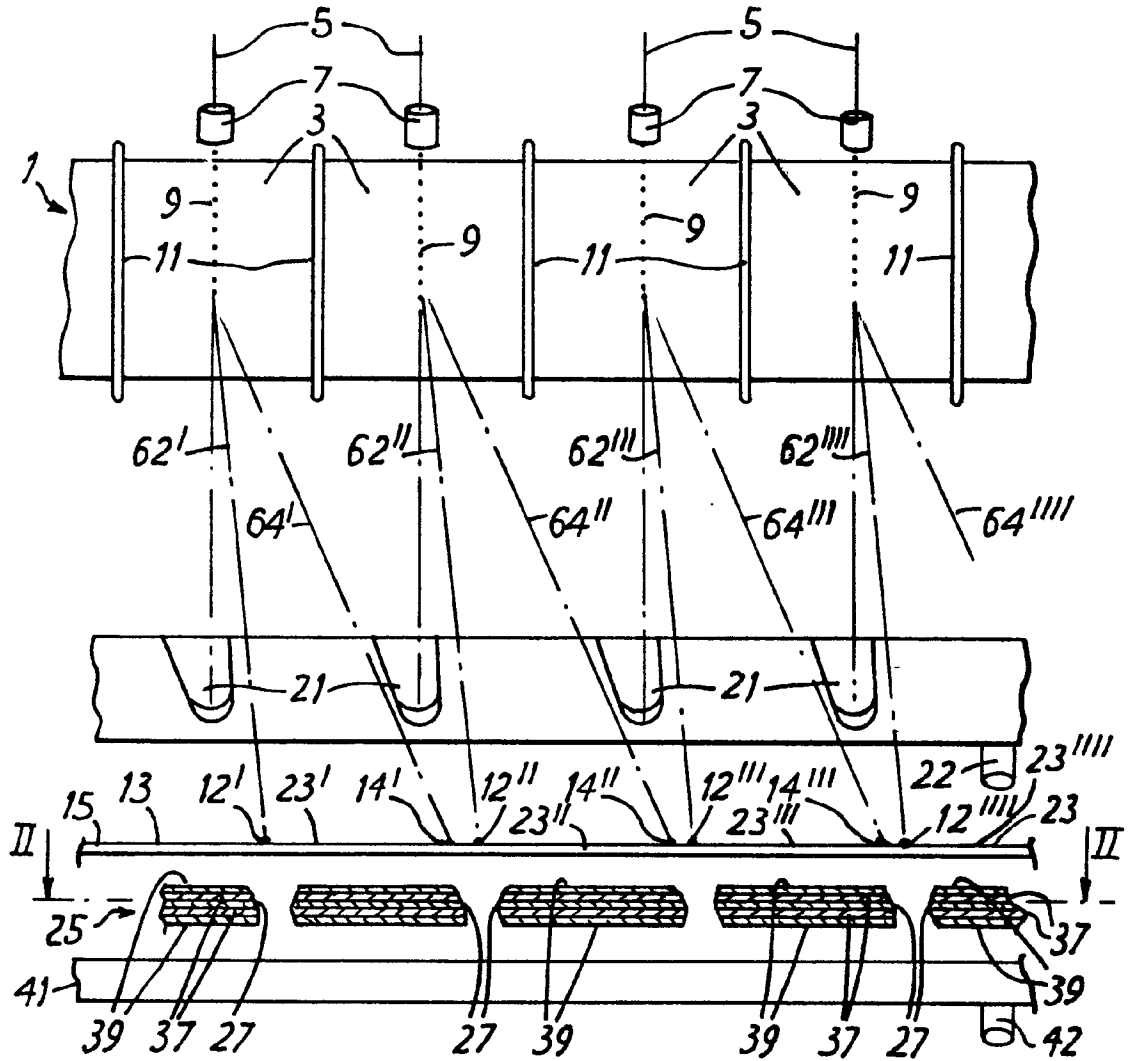

FIG.2

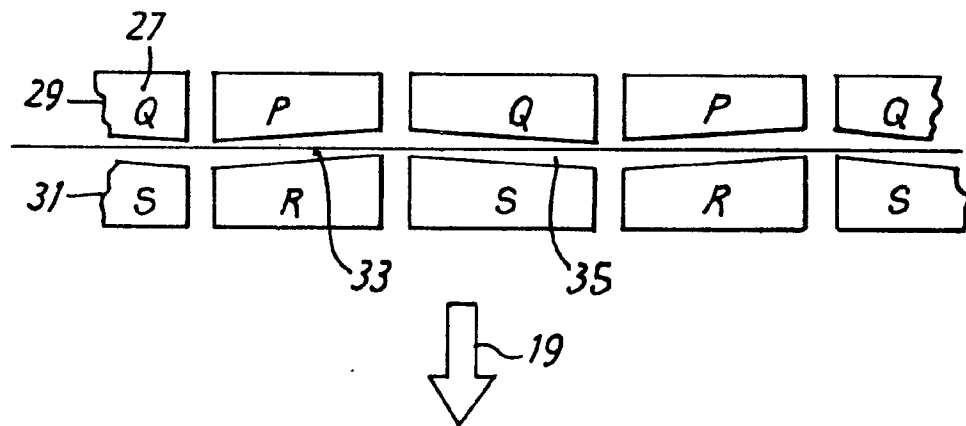
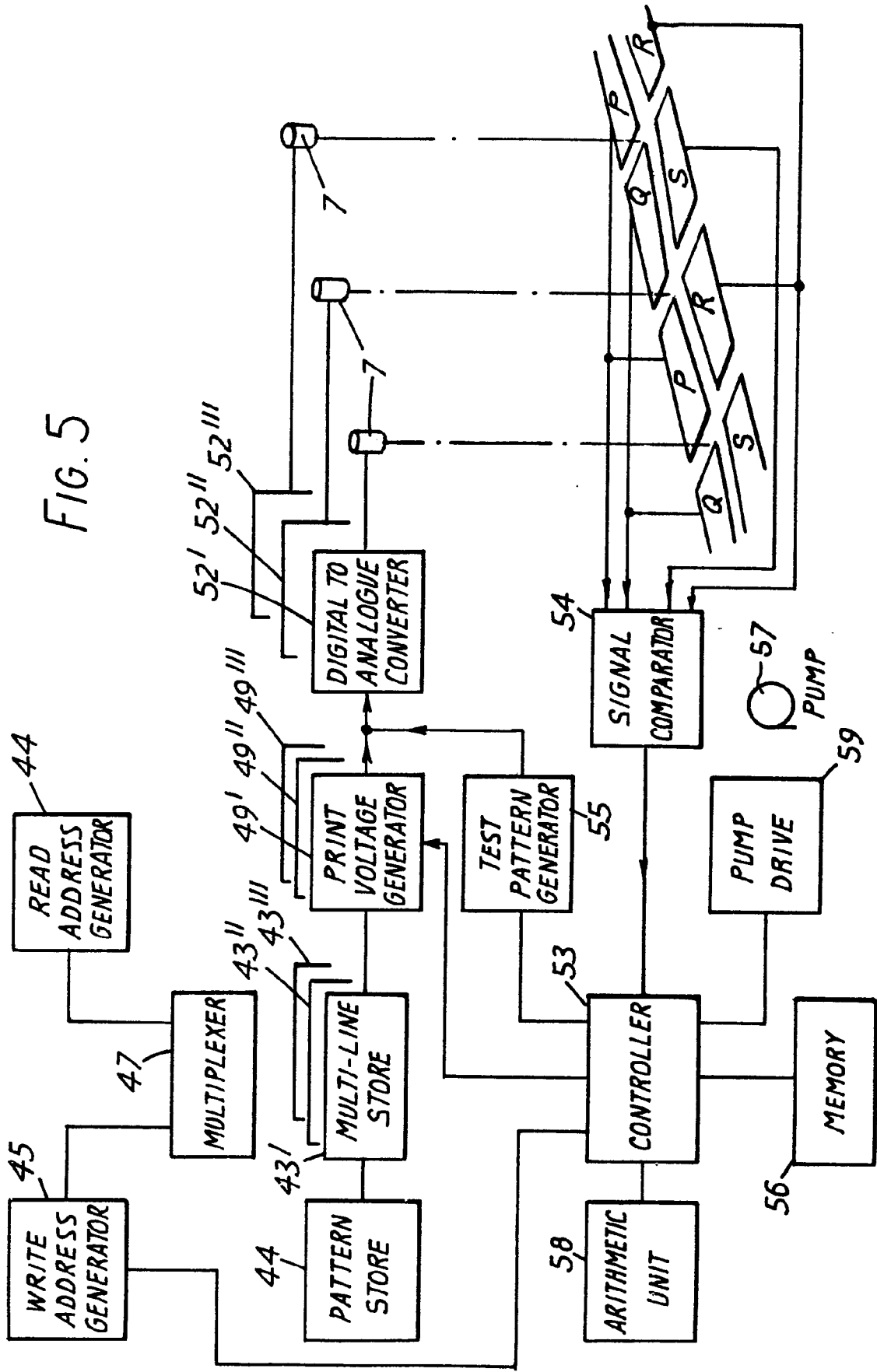

FIG. 5





DOCUMENTS CONSIDERED TO BE RELEVANT			CLASSIFICATION OF THE APPLICATION (Int. Cl.)
Category	Citation of document with indication, where appropriate, of relevant passages	Relevant to claim	
P	<u>EP - A1 - 0 015 727</u> (XEROX CORP.) * fig. 2 *	1	B 41 J 3/04
A	<u>US - A - 3 769 630</u> (IBM CORP.) * complete document *		
A	<u>DE - A1 - 2 759 067</u> (IBM CORP.) * complete document * & US - A - 4 158 204		
A	<u>DE - A1 - 2 611 282</u> (HITACHI LTD.) * complete document * & US - A - 4 060 813		
			TECHNICAL FIELDS SEARCHED (Int. Cl.)
			B 41 J 3/00 G 01 D 15/02
			CATEGORY OF CITED DOCUMENTS
			X: particularly relevant A: technological background O: non-written disclosure P: intermediate document T: theory or principle underlying the invention E: conflicting application D: document cited in the application L: citation for other reasons
			&: member of the same patent family, corresponding document
<input checked="" type="checkbox"/> The present search report has been drawn up for all claims			
Place of search	Date of completion of the search	Examiner	
Berlin	24-06-1981	ZOFF	