

⑫ **EUROPEAN PATENT SPECIFICATION**

⑬ Date of publication of patent specification: **12.12.84**

⑮ Int. Cl.³: **E 04 B 1/82, E 01 F 8/00,
E 04 B 1/40, E 04 B 2/78**

⑰ Application number: **81200522.1**

⑱ Date of filing: **11.05.81**

⑤④ **Sound damping wall.**

③⑩ Priority: **09.05.80 NL 8002686**

④③ Date of publication of application:
18.11.81 Bulletin 81/46

④⑤ Publication of the grant of the patent:
12.12.84 Bulletin 84/50

④④ Designated Contracting States:
AT BE CH DE FR GB IT LI LU NL

⑤⑥ References cited:

**AT-A- 340 988
CH-A- 607 567
DE-A-2 419 154
DE-B-1 784 953
FR-A-2 152 072
FR-A-2 451 967
NL-A-7 500 811
US-A-4 143 495
US-A-4 214 411
US-A-4 235 054**

**POLYTECHNISCH TIJDSCHRIFT EDITIE
BOUWKUNDE WEGEN- EN WATERBOUW, vol.
33, no. 2, February 1978 Stam B.V. THE HAGUE
(NL) W.G. DE JAGER: "Verkeerslawaaai 12*
maatregelen ter vermindering van
geluidhinder" pages 104-115**

⑦③ Proprietor: **VAPOTHERM B.V.
Steekterweg 92
NL-2407 BH Alphen a/d Rijn (NL)**

⑦② Inventor: **van Loenen, Cornelis Jan Marinus
Groot Haesebroekseweg 296
Wassenaar (NL)**

⑦④ Representative: **Kooy, Leendert Willem et al
OCTROOBUREAU VRISENDORP & GAADE
P.O. Box 266
NL-2501 AW The Hague (NL)**

⑤⑧ References cited:
**HIGHWAYS AND ROAD CONSTRUCTION, vol.
41, no. 1761, May 1973 Embankment Press
WEMBLEY (GB) J.B. HAUSKINS et al.:
"Kinematic motorway sound screen" page 40
RAILWAY GAZETTE INTERNATIONAL, vol. 130,
no. 9, September 1974 I.P.C. Transport Press
LONDON (GB) R.J. MURRAY: "Suppressing
noise and vibration in the subway" pages
337-341**

Note: Within nine months from the publication of the mention of the grant of the European patent, any person may give notice to the European Patent Office of opposition to the European patent granted. Notice of opposition shall be filed in a written reasoned statement. It shall not be deemed to have been filed until the opposition fee has been paid. (Art. 99(1) European patent convention).

Description

The invention is related to a sound damping wall comprising panels which are attached by connecting means to posts having a H-shaped cross-section, said connecting means getting a greater thickness in the direction perpendicular to the panels when loaded parallelly to the surface of the panel, and perpendicular to the posts by bolts and nuts.

Such a wall is known from CH—A 607 567. The connecting means of that known wall have an irregular S-like cross-section. There is a line-contact between the post and a kink between two straight parts of the cross-section of the connecting means. This feature can easily lead to vibrations. The engagement between the panel and the connecting means is based upon the elasticity of a circle-sector-shaped part of the cross-section of the connecting means. This elasticity will certainly be not very permanent so that it will not take very long until the panels start vibrating under the influence of wind and the traffic racing by. Not only can this lead in itself to noise pollution, but the posts can also start to vibrate as a result. These vibrations can then travel through the ground of the dwellings to be protected unless a ditch of adequate depth can be dug at the rear side of the wall. Of course, there is not always enough room for such a ditch and, furthermore, such a ditch entails extra digging and maintenance costs.

The invention now aims at producing a sound damping wall which abolishes the above-mentioned disadvantages and problems. Moreover, the invention aims at producing a wall, which can be manufactured and positioned simply and therefore cheaply, it being taken into account that the reflections of the noise will not reach any unacceptable values if the massive panel has a minimum weight for every surface unit.

The invented wall now has as characterizing features that said panels consist of plywood surrounded by a border of tropical lumber known as azobé, and in that said connecting means consist of U-profiles having legs, a base and bevelled edges connecting the legs to that base.

The invention will be elucidated in more detail below with the aid of the drawing in which, by way of example, some details of a sound damping wall according to the invention are shown.

In the drawing there is shown:

Fig. 1 a horizontal section through a post, a panel and a connecting means, and

Fig. 2 a view of the direction of arrow A of Fig. 1.

Most of the sound damping walls placed along busy thoroughfares are constructed by placing posts 1, having a H-shaped cross-section at a certain mutual distance, such as 3 m. The parallel legs 2 and 3 of this profile are parallel to the thoroughfare and the centre

piece 4 is perpendicular thereto. The distance between the parallel legs 2 and 3 is so great that a panel 5 easily fits inbetween, so that enough room remains for a connecting means 6.

Panel 5 consists of a border 7 of azobé, and a multiplex plate 8 of preferably 18 mm thickness, which is contained in grooves of the border. The azobé border parts of preferably the dimension 50×100 mm are connected to one another in a known manner by wooden pins and preferably the cooperation between the border and the plate is improved even more with the aid of kit 9 in the grooves and/or kit 10 in the connection corners. As shown in Fig. 2 an extra recess can be placed in the border parts 7 for the benefit of kit 10. The panels are manufactured in a number of standard heights and are placed as a unit between the posts 1. To support the panels, corner profiles 11 are welded firmly to the posts on a level with the land.

The connecting means 6 consist in Fig. 1 of U-profiles extending over the height of a panel, leg 12 of said U-profiles possibly being somewhat longer than the other leg 13. The base part 14 of the U-profile is connected to the legs by means of bevelled edges 15. If the screw connection consisting of bolt 16 and nut 17 is now tightened, the base part 14 and the bevelled edges 15 will, at a given moment, want to come in each other's path, which will lead to a strong clamping action. If the left-hand space in Fig. 1 between legs 2 and 3 of the H-profile is also occupied by a panel, one should dispose of longer bolts 16.

Claim

A sound damping wall comprising panels (5) which are attached by connecting means (6) to posts (1) having an H-shaped cross-section, said connecting means getting a greater thickness in the direction perpendicular to the panels when loaded parallelly to the surface of the panel and perpendicular to the posts by bolts (16) and nuts (17), characterized in that said panels consist of plywood (8) surrounded by a border (7) of tropical lumber known as azobé, and in that said connecting means (6) consist of U-profiles having legs (12, 13) a base (14) and bevelled edges (15) connecting the legs to that base.

Revendication

Ecran atténuant le bruit comportant des panneaux (5) fixés par des moyens de raccordement (6) à des poteaux (1) avant une section en forme de H, lesdits moyens de raccordement devenant de plus en plus épais dans la direction perpendiculaire aux panneaux lorsqu'ils sont chargés, parallèlement à la surface du panneau et perpendiculairement aux poteaux, par de boulons (16) et d'écrous (17), caractérisé en ce

que lesdits panneaux consistent en du bois triplex (8) entouré par un bord (7) de bois tropical, connu comme l'azobé, et en ce que lesdits moyens de raccordement (6) comportant des profils en forme d'U ayant des jambes (12, 13), une base (14) et des biseaux (15) qui raccordent les jambes à cette base.

Patentanspruch

Eine Schaldämpfende Mauer mit Paneelen (5) die mittels Kupplungsmittel (6) Pfosten (1) mit einem H-förmigen Querschnitt zugeordnet sind, wobei die Kupplungsmittel eine grössere

Dicke in die Richtung senkrecht auf die Paneele bekommen wenn sie parallel zu der Ebene des Paneeles und senkrecht zu den Pfosten belastet werden mittels Bolzen (16) und Muttern (17, dadurch gekennzeichnet, dass diese Paneele aus Sperrholz (8) bestehen, die einer Einrahmung (7) von tropischem Holz, das bekannt ist als Azobé, umgeben sind, und dadurch dass diese Kupplungsmittel (6) aus U-förmigen Profilen mit Schenkeln (12, 13), einer Grundfläche (14) und abgeschrägten Rändern (15), die die Schenkeln mit der Grundfläche verbinden, bestehen.

5

10

15

20

25

30

35

40

45

50

55

60

65

3

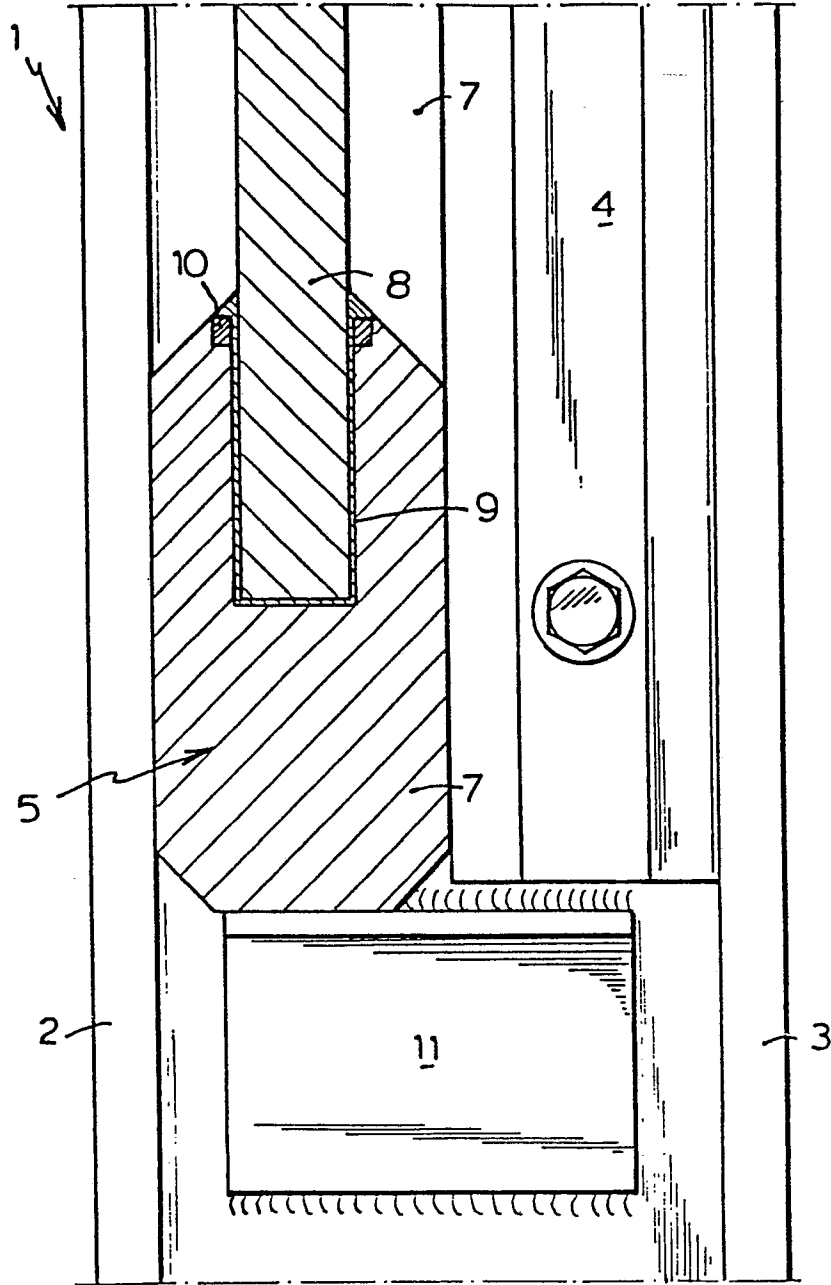

FIG. 2