

⑫

**EUROPEAN PATENT SPECIFICATION**

④⑤ Date of publication of patent specification: **07.11.84**

⑥① Int. Cl.<sup>3</sup>: **A 62 B 7/00**

②① Application number: **81304141.5**

②② Date of filing: **10.09.81**

⑤④ **Breathing apparatus.**

③⑩ Priority: **10.09.80 GB 8029301**  
**30.01.81 GB 8102795**

④③ Date of publication of application:  
**17.03.82 Bulletin 82/11**

④⑤ Publication of the grant of the patent:  
**07.11.84 Bulletin 84/45**

⑧④ Designated Contracting States:  
**DE FR IT NL SE**

⑤⑧ References cited:  
**GB-A- 909 067**  
**GB-A- 940 581**

⑦③ Proprietor: **CHUBB PANORAMA LIMITED**  
**Christie Place**  
**South Bersted Industrial Estate Bognor Regis**  
**PO22 9RT (GB)**

⑦② Inventor: **Feathers, Leonard John**  
**27 Beechings**  
**Henfield Sussex BN5 9XB (GB)**

⑦④ Representative: **Obee, Robert William**  
**Manor House Manor Lane**  
**Feltham Middlesex TW13 4JQ (GB)**

Note: Within nine months from the publication of the mention of the grant of the European patent, any person may give notice to the European Patent Office of opposition to the European patent granted. Notice of opposition shall be filed in a written reasoned statement. It shall not be deemed to have been filed until the opposition fee has been paid. (Art. 99(1) European patent convention).

**EP 0 047 676 B1**

## Description

The present invention relates to self-contained breathing apparatus such as may be worn, e.g. by firemen, rescue workers and the like who are required to perform tasks in noxious or oxygen depleted environments, or by divers.

Conventionally such apparatus comprises a cylinder of compressed air or oxygen supported by a harness worn by the user, and a facemask, mouthpiece or the like breathing interface means to which gas is supplied from the cylinder via a flowpath which includes so-called lung-controlled or demand valve responsive to the respiration of the user to admit gas to the mask or the like at the variable rate necessary to satisfy the breathing need. In some examples the pressure of the supplied gas is reduced from the value at which it is stored in the cylinder to a regulated intermediate value by a first stage pressure reducer located in the flowpath upstream of a separate demand valve, while in others the appropriate pressure reduction and flow control is achieved by the demand valve alone. In either case there is invariably a shut-off valve associated with the cylinder for shutting off the gas supply while the apparatus is not in use. Additionally it is usual to provide a pressure gauge located remote from the cylinder at a position where it can readily be seen by the user, e.g. supported by the harness on the user's chest, to indicate the state of charge of the cylinder during use. For this purpose a hose from the gauge is tapped in to the gas supply flowpath at a suitable position downstream from the shut-off valve but upstream of the pressure-reducing means.

With breathing apparatus as described above having only a single flowpath through which gas can be supplied from the cylinder to the mask or the like, in the event of malfunction or damage to the demand valve which results in a blockage of the flowpath or alternatively an uncontrolled escape of gas therefrom the flow of gas to the mask or the like will be substantially reduced or complete interrupted, with potentially dire results. In recognition of this possibility, therefore, it is known to provide an additional flowpath bypassing the flow-controlling elements of the demand valve which can be brought into operation to supply gas from the cylinder to the mask or the like in the event of any such occurrence. One such system is shown in GB—A—909067 where a second flowpath bypasses both a first-stage pressure reducer and the main demand valve and terminates at the interface means in a second demand valve adapted to open at an inhalation pressure lower than that for which the main demand valve opens. When required to use the bypass, therefore, the user may experience significant breathing resistance in operating the second demand valve. In other known breathing apparatus the bypass line is controlled by a second shut-off valve opening from the main high-pressure shut-off

valve and incorporates a length of capillary hose to reduce the pressure of the supplied gas as it flows directly to the interface means. However, the use simply of a length of capillary hose to achieve pressure-reduction in the bypass does not permit the most favourable flowrate characteristics to be achieved throughout the range of cylinder pressures and breathing rates to be expected in practice.

The present invention accordingly seeks to provide a bypass breathing system where certain of the drawbacks of prior art systems can be overcome and resides in breathing apparatus comprising: a source of pressurised breathing gas; breathing interface means; a first flowpath to lead gas from said source to said interface means, and including at least a shut-off valve and a demand valve arranged normally to control the flow of breathing gas into the interface means; and a second flowpath to lead gas from said source to said interface means independently of the flow-controlling elements of the demand valve, characterised in that said second flowpath includes a combined shut-off valve and pressure-regulator comprising: a piston slidably borne within a chamber; an inlet to the chamber at one end thereof; one end of the piston being adapted to co-operate with said inlet to control the flow of gas there-through; an outlet from the chamber downstream of said one end of the piston; means providing gaseous communication between said one end of the chamber and its opposite end; the opposite end of the piston being of greater effective cross-sectional area than said one end thereof; and manual control means which are operable selectively to urge the piston into a position in which its said one end seats in relation to the chamber inlet to shut off the gas flow therethrough, or to release the piston for sliding movement within the chamber to regulate the pressure of gas supplied through the second flowpath.

Preferably, both of the above-mentioned shut-off valves are provided in a common valve assembly which comprises a body having a main supply passage to lead gas from the pressurised source, with both said shut-off valves mounted to said body; and preferably a cylinder pressure gauge and/or cylinder pressure relief means (e.g. a burst disc) also mounted to said body; with each of said shut-off valves, any said pressure gauge and any said pressure relief means communicating independently of one another with said passage. Preferably the body is of generally rectangular plan form with the first shut-off valve mounted to a first side thereof, the second shut-off valve mounted to a second side thereof and any said pressure gauge and/or pressure relief means mounted to a third side thereof.

These and other features of the present invention will now be more particularly described, by way of example, with reference to the accompanying drawings, in which:

Figure 1 is a pictorial illustration of the respiratory system of a breathing apparatus according to the invention, as in use;

Figure 2 is a schematic block diagram of the respiratory system of Figure 1;

Figure 3 is a partly-sectioned bottom plan view of the cylinder valve assembly employed in the respiratory system of Figures 1 and 2;

Figure 4 is a section on the line IV—IV of Figure 3, to an enlarged scale; and

Figure 5 is a section on the line V—V of Figure 4.

Referring to Figures 1 and 2, the breathing apparatus includes a cylinder 1 of compressed air which in use is supported on the user's back in the conventional inverted attitude by means of a suitable harness assembly (not shown). In normal operation air for breathing is lead out of the cylinder 1 through a shut-off valve 2 to a first stage pressure reducer 3 which in accordance with known techniques provides air via a low pressure hose to a demand valve 5 at a substantially constant, reduced pressure.

The demand valve 5, which functions to admit air to a facemask 6 at a variable rate in response to the respiratory efforts of the user, is preferably constructed in accordance with the invention disclosed in our published United Kingdom patent application no. 2054207 and coupled to a tube inlet of the facemask. Exhaled air is vented from the facemask through a conventional exhalation valve 8.

Opening from the main air supply flowpath described above, at a position downstream of the shut-off valve 2 but upstream of the working parts of the pressure reducer 3, is a high pressure hose 9. This hose leads to a remote pressure gauge and low cylinder pressure warning whistle 10 of conventional form, located e.g. on the user's chest at a position where the reading of the gauge, indicative of the state of charge of the cylinder 1, can be easily seen.

Connected to the cylinder 1 in parallel with the main shut-off valve 2 is a second shut-off valve 11 which also combines the function of a pressure reducer as will be more fully described hereinafter. From the valve 11 a second low pressure (bypass) hose 12 leads to the facemask 6, to open into the inlet 7 of the mask through a connector 7A at a position downstream of the working parts of the demand valve 5. In normal operation the valve 11 is maintained closed. However, in the event of a malfunction of, or damage to, any of the components 2, 3, 4, 5 of the main air supply flowpath or of the gauge/whistle spur 9, 10 which results in a reduction or interruption of the flow of air to the mask 6, the valve 2 can be closed to isolate the main flowpath from the cylinder 1 and the valve 11 can be opened to maintain a supply of air from the cylinder to the mask via the hose 12. It will be noted that the flowpath provided by the components 11 and 12 leads directly from the cylinder 1 to the mask 6, bypassing all of the components of the main

supply flowpath including the valve 2.

The two valves 2 and 11 are incorporated in a unitary valve assembly 13 secured to the cylinder 1, together with two other components which form permanent parts of the cylinder assembly, viz a second pressure gauge 14 and a burst disc unit 15, the latter to protect against over-pressure in the cylinder. The construction of the valve assembly 13 will now be more fully described with reference to Figures 3, 4 and 5.

The assembly 13 comprises a body 16 of generally rectangular plan form with two long slab sides 17, 18 and a threaded spigot 19 by which the assembly is screwed into the neck of the cylinder (not shown) to be sealed there-against with an O-ring 20. Adjacent to the spigot 19 the body 16 has a neck provided with an external annular groove 21 whereby the cylinder assembly can be supported by a slotted mounting bracket in accordance with the invention disclosed in our published United Kingdom patent application no. 2064636. The spigot 19 carries a dip tube 22 (Figure 4) through which air from the cylinder is led to a central bore 23 in the body, the bore 23 intersecting with four further bores 24—27.

The first intersecting or sub-bore 24 is aligned with the longitudinal direction of the body (i.e. as represented by the axis A in Figure 3) and receives the screw-threaded spigot 28 of the cylinder pressure gauge 14 (Figure 5) sealed to the bore by an O-ring 29. The mechanism of the gauge can be of conventional form, including an automatic self-sealing valve which closes in the event of any leakage of air out of the bore through the gauge.

The second sub-bore 25 intersects with the bore 23 at right-angles to the longitudinal direction of the body 16 and leads to a screw-threaded spigot 30 opening from the side 17 of the body (Figures 3 and 4). In this part of the body there is a chamber 31 which receives in screw-threaded relation a barrel 32 retaining the conical head 33 of the main shut-off valve 2. The valve further comprises a hand-wheel 34 with a stem 35 journaled in an extension 36 of the chamber 31 and retained by a cap 37 screwed on to the spigot 30. An O-ring 38 surrounding the stem 35 seals the chambers 31/36 against leakage.

The valve head 33 co-operates with a seat defined at the junction of the bore 25 with the chamber 31, and the head can be moved towards or away from the seat to close or open the valve by rotation of the handwheel 34 in the appropriate sense. Rotation of the handwheel is transmitted from its stem 35 to the barrel 32 through a non-circular drive link 39 which permits the relative axial movement between the barrel and stem occasioned by the barrel's screw-threaded mounting. Rotation of the barrel 32 to withdraw the head 33 from its seat and thereby open the valve 2 permits air to flow from the bore 25 to the chamber 31 and thence

through a bore 40 which leads from the chamber to a threaded spigot 41 opening from the opposite side 18 of the body 16, the axis of the bore 40 and spigot 41 being parallel to, but offset from, the axis of the bore 25 and spigot 30.

In the assembled breathing apparatus the bore 40 leads air to the pressure reducer 3 of the main flowpath, shown in chain line in Figure 3. This pressure reducer does not form part of the cylinder valve assembly 13 proper but is demountably attachable thereto by means of a knurled ring 42 held captive on the body of the reducer and screwed onto the spigot 41. In other words the reducer remains assembled with the demand valve, mask and harness of the breathing apparatus throughout each use of the apparatus, and when the cylinder assembly (i.e. the cylinder 1 together with the valve assembly 13) is replaced during use or between uses the reducer 3 is detached from the spigot 41 of the old cylinder assembly and reattached to the corresponding spigot of its replacement. The high pressure and low pressure hoses 9 and 4 lead from the body of the reducer 3 respectively upstream and downstream of its working parts. The spigot 41 is also used as the inlet to the cylinder assembly when being refilled.

The third sub-bore 26 (Figure 5) is aligned with the longitudinal direction of the body 16, i.e. parallel with the pressure gauge bore 24, and leads from the central bore 23 towards the same short side 43 of the body as does the bore 24. The bore 26 opens out into a larger diameter tapped bore 44 into which the burst disc unit 15 is screwed and sealed by an O-ring 45. The unit 15 comprises a housing 46 in the form of a hollow nut having a tapped bore 47 opening to the bore 44 and within which the burst disc itself (48) is clamped by means of a screw-threaded sleeve 49. A passage 50 leads from the downstream end of the bore 47 to openings 51 in the head of the housing 46 so that in use the disc 48 is subjected to the difference between the cylinder pressure transmitted to bore 44, and ambient. In the event of the cylinder becoming over-pressurised, through being overheated or otherwise, the disc 48 is adapted to rupture to vent the cylinder contents through the openings 51.

The fourth sub-bore 27 (Figure 5) is also aligned with the longitudinal direction of the body 16 and opens from the central bore 23 opposite to the burst disc bore 26. It leads to a stepped-diameter chamber 52A/B/C within which is the piston 53 of the combined shut-off valve and pressure reducer 11 of the bypass flowpath. The piston 53 is of stepped diameter matching the first two sections 52A, 52B of the chamber and is slidably sealed thereagainst by respective O-rings 54 and 55. Between the two O-rings the chamber is vented through an opening 56. The valve further comprises a handwheel 57 with a stem 58 screwed into a tapped extension 59 of the chamber 52 and sealed against the chamber section 52C by an O-ring

60. The handwheel 57 is aligned at right-angles to the handwheel 34 of the main shut-off valve 2 and is of a different shape so that the user can readily distinguish between them by touch alone.

In the illustrated shut-off condition of the valve 11 the stem 58 is screwed in so that its nose portion 61 bears against the downstream face of the piston 53 to press the conical head 62 of the piston against a seat defined at the junction of the bore 27 with the chamber 52. This is the condition adopted in normal operation of the breathing apparatus, when the main shut-off valve 2 is open. However, in the event of an emergency which requires the user to breathe through the by-pass flowpath he can close the valve 2 and open the valve 11 by turning the handwheel 57 to screw out the stem 58 until it abuts a stop pin 63.

With the stem 58 shifted to the right (in the sense of Figure 5) in this manner the piston 53 is free also to slide to the right under the influence of the cylinder pressure applied to bore 27, thereby admitting air from the cylinder to the portion of the chamber 52 upstream of the O-ring 54. From here the air can flow through a passageway 64 in the piston to the portion of the chamber 52 downstream of the O-ring 55. This flow is permitted even when, as is the case initially, the piston is urged by the cylinder pressure hard against the nose 61 of the withdrawn stem, as the nose is provided with transverse slots 65 through which the air from passageway 64 can escape.

Intersecting the chamber section 52C at right-angles is a further bore 66 opening through the side 18 of the body 16 as indicated in Figure 3. This bore constitutes the outlet from the valve assembly 13 for the bypass flowpath and plugged into it is a hollow spigot 67 connected to the by-pass hose 12. The spigot 67 is a simple push fit in the bore 66 and is sealed thereagainst by an O-ring 68. In use the spigot is held in place in the bore by virtue of the overlap of the knurled ring 42 of the main pressure reducer 3 with the flange 69 of the spigot, as indicated in Figures 3 and 5. This provides a simple but secure means of connecting up the by-pass hose 12 to the cylinder assembly, together with the reducer 3, whenever a cylinder assembly is changed.

From the foregoing it will be appreciated how the shut-off function of the piston 53 is performed and that the route by which air from the cylinder 1 is made available to the bypass hose 12 is independent of the main shut-off valve 2. The piston 53, however, furthermore serves a regulatory function in respect of the pressure and flowrate of the air fed to the bypass hose 12, as will now be described.

If the valve 11 is opened while the cylinder remains at its full pressure, conditions are established, it is speculated, such that the flow of air passing through the bore 27 and into the chamber section 52A attains a supersonic

velocity, or in other words that the flow of air in the bore 27 becomes "choked"; under these choked conditions the rate of flow which the bore 27 is capable of passing is limited. These conditions prevail so long as the ratio of the cylinder pressure upstream of the bore 27 to the pressure in the chamber section 52A downstream of the bore 27 is above a certain critical value. However, as the cylinder becomes progressively depleted the upstream pressure will begin to fall until at a certain value the conditions for choked flow no longer exist and the flow velocity through bore 27 falls to a subsonic value. At this juncture, in the absence of the piston 53, the transition to subsonic flow would normally lead to an increase in the overall flow rate through the bypass path to a value considerably in excess of that required for respiration and, bearing in mind that the bypass hose leads directly into the facemask and the bypass flow is not subject to the regulatory effects of the demand valve, the excess air would vent directly from the facemask through its exhalation valve, thereby rapidly exhausting the air remaining in the cylinder. However, in order to conserve the air supply and prevent such wastage the piston 53 now takes on a regulatory function, as follows.

The position of the piston at any time is determined by the balance of thrust on its upstream and downstream faces, or in other words on the difference between the pressure upstream of the O-ring 54 integrated over the effective upstream surface area of the piston and the pressure downstream of the O-ring 55 integrated over the effective downstream surface area of the piston. As will be appreciated, the piston has a greater effective downstream surface area than upstream surface area. Furthermore the pressure downstream of O-ring 55 and the pressure upstream of O-ring 54 are related by virtue of the connection made between the upstream and downstream ends of the piston by its passageway 64, a certain pressure drop being encountered by the flow passing through this passageway.

While the cylinder pressure remains at a value which results in choked flow in the bore 27, the balance of thrust on the piston 53 is such as to maintain it in its rightward position against the nose 61 of the withdrawn stem 58. After the transition to subsonic flow, however, both the upstream and downstream pressures acting on the piston increase to the extent that the thrust on the downstream face now overcomes that on the upstream face with the result that the piston shifts leftwards back towards its seated position. As the piston moves in this direction its conical head 62 encounters the orifice at the junction of the bore 27 with the chamber 52 and restricts the cross-sectional area available for air flow through this orifice, thereby limiting the overall flowrate through the bypass path and reducing the upstream and downstream pressures acting on the

piston. The actual position adopted by the piston is of course that in which the orifice is restricted to the extent which results in the upstream and downstream thrusts on the piston cancelling out. As the cylinder gradually exhausts and its pressure reduces so the piston moves gradually rightwards again under the balance of the upstream and downstream pressure forces, so that its head 63 opens up the associated orifice to compensate for the falling cylinder pressure. The result of this action is to give an approximately constant bypass flow for the period following the transition from choked flow and to permit the air supply to be conserved for a period long enough for the user of the apparatus to make an escape following the changeover to "bypass" breathing, even if that change-over is made at a relatively late stage during a working cycle.

The geometry of the valve assembly described in relation to Figures 3 to 5 permits its various component parts to be disposed in juxtaposition in a highly compact manner, as will be appreciated from a consideration of those figures. In particular an assembly 13 as illustrated, together with the pressure reducer 3, can be mounted to a cylinder of, say, seven inches (178 mm) diameter with no part of the assembly protruding outside the bounds of the project area of the cylinder, as indicated at 1 in Figure 3. By shrouding all of the components beneath the cylinder in this way the risks of, say, damage to the pressure gauge 14 or inadvertent turning of the handwheels 34 and 57, are reduced.

#### Claims

1. Breathing apparatus comprising: a source (1) of pressurised breathing gas; breathing interface means (6); a first flowpath (4) to lead gas from said source (1) to said interface means (6), and including at least a shut-off valve (2) and a demand valve (5) arranged normally to control the flow of breathing gas into the interface means (6); and a second flowpath (12) to lead gas from said source (1) to said interface means (6) independently of the flow-controlling elements of the demand valve (5), characterised in that said second flowpath (12) includes a combined shut-off valve and pressure-regulator (11) comprising: a piston (53) slidably borne within a chamber (52); an inlet (27) to the chamber (52) at one end (52A) thereof; one end (62) of the piston (53) being adapted to cooperate with said inlet (27) to control the flow of gas therethrough; an outlet (66) from the chamber (52) downstream of said one end (62) of the piston (53); means (64) providing gaseous communication between said one end (52A) of the chamber (52) and its opposite end (52C); the opposite end of the piston (53) being of greater effective cross-sectional area than said one end (62) thereof; and manual control means (61) which are operable selectively to

urge the piston (53) into a position in which its said one end (62) seats in relation to the chamber inlet (27) to shut off gas flow therethrough, or to release the piston (53) for sliding movement within the chamber (52) to regulate the pressure of gas supplied through the second flowpath (12).

2. Breathing apparatus according to claim 1 wherein said chamber (52) is of stepped bore and said piston (53) is of stepped diameter with the different diameter portions of the piston (53) being slidably sealed (54, 55) against respective portions (52A, 52B) of the chamber bore; and the said one end of the piston is provided as a conical nose (62) adapted to seat in relation to said inlet (27) and, when the piston (53) is released for sliding movement as aforesaid, to control the effective cross-sectional area of said inlet (27) available for gas flow as a function of the axial position of the piston (53) in the chamber (52).

3. Breathing apparatus according to claim 2 wherein the piston (53) includes a passageway (64) one end of which opens to said chamber (52) through the piston (53) at a position between said conical nose (62) and the slidable sealing means (54) of the smaller diameter portion of the piston (53), and which extends axially through the piston (53) to open to said chamber (52) at its opposite end through the opposite end of the piston (53).

4. Breathing apparatus according to any one of claims 1 to 3 wherein said control means comprise a manually-controllable member (61) movable between a first position in which it engages the said opposite end of the piston (53) to maintain the piston in the position in which its said one (62) end seats in relation to the chamber inlet (27), and a second position spaced from the first in which the piston (53) is released for sliding movement within the chamber (52).

5. Breathing apparatus according to any preceding claim wherein both the first (2) and second-mentioned (11) shut-off valves are provided in a common valve assembly (13) which comprises a body (16) having a main gas supply passage (23) leading from said pressurised source (1) with each said-shut-off valve (2, 11) mounted to said body (16) and communicating with said supply passage (23) independently of one another.

6. Breathing apparatus according to claim 5 wherein said valve assembly (13) further comprises a pressure gauge (14) and/or pressure relief means (15) mounted to said body (16) and communicating with said supply passage (23) independently of one another and independently of both said shut-off valves (2, 11).

7. Breathing apparatus according to claim 5 or claim 6 wherein said body (16) is of generally rectangular plan form with the first-mentioned shut-off valve (2) mounted to a first side (17) thereof, the second-mentioned shut-off valve (11) mounted to a second side thereof,

and any said pressure gauge (14) and/or pressure relief means (15) mounted to a third side thereof.

8. Breathing apparatus according to claim 7 wherein both an outlet connection (41) from the first-mentioned shut-off valve (2) leading to said interface means (6) and an outlet connection (66) from the second-mentioned shut-off valve (11) leading to said interface means (6) are located to the fourth side (18) of said body (16).

9. Breathing apparatus according to claim 8 wherein said outlet connection from the first-mentioned shut-off valve (2) is in the form of a screw-threaded spigot (41) to which a pressure-reducing means (3) of the first flowpath (4) is secured by means of a screw-threaded ring (42), and said outlet connection from the second-mentioned shut-off valve (11) is in the form of a socket (66) into which a spigoted connector (67) of the second flowpath (12) is inserted, said connector (67) being retained in said socket (66) by the overlapping engagement therewith of a peripheral portion of said ring (42).

10. Breathing apparatus according to any one of claims 5 to 9 in which said valve assembly (13) is secured to a pressurised gas source provided by a cylindrical container (1) and the parts of said first (2) and second-mentioned (11) shut-off valves and any said pressure gauge (14) and/or pressure relief means (15) are disposed entirely within the projected cross-sectional area of said cylindrical container (1).

#### Patentansprüche

1. Atemgerät, bestehend aus einer Quelle (1) eines unter Druck stehenden Atemgases, einem Atmungsanschlußteil (6), einem ersten Strömungsweg (4), um Gas von der Quelle (1) zum Anschlußteil (6) zu leiten und bestehend aus mindestens einem Schließventil (2) und einem Bedarfsventil (5), welches normalerweise angeordnet ist zur Steuerung der Strömung des Atemgases in das Anschlußteil (6), und einem zweiten Strömungsweg (12) um Gas von der Quelle (1) zum Anschlußteil (6) unabhängig von den durchflußsteuernden Elementen des Bedarfsventils (5) zu leiten, dadurch gekennzeichnet, daß der zweite Strömungsweg (12) ein kombiniertes Schließventil und Druckregler (11) umfasst, bestehend aus: einem gleitbar in einer Kammer (52) angeordneten Kolben (53), einem an einem Ende (52A) der Kammer (52) angeordnete Einlaß (27), wobei ein Ende (62) des Kolbens (53) zum Zusammenwirken mit dem Einlaß (27) ausgebildet ist, um die Gasströmung durch den Einlaß (27) zu steuern, einem Auslaß (66) von der Kammer (52) in Strömungsrichtung von dem einen Ende (62) des Kolbens (53), einer Gasverbindung (64) zwischen dem einen Ende (52A) der Kammer (52) und ihrem gegenüberliegenden Ende (52C), wo-

bei das gegenüberliegende Ende des Kolbens (53) eine größere wirksame Querschnittsfläche aufweist als sein eines Ende (62), und manuellen Steuerteilen (61), die wahlweise betätigbar sind, um den Kolben (53) in eine Stellung zu drücken, in welcher sein eines Ende (62) in Bezug auf den Kammereinlaß (27) aufsitzt, um die Gasströmung durch ihn hindurch zu unterbrechen, oder um den Kolben (53) für eine Gleitbewegung innerhalb der Kammer (52) freizugeben, um den Druck des durch den zweiten Strömungsweg (12) zugeführten Gases zu regulieren.

2. Atemgerät nach Anspruch 1, dadurch gekennzeichnet, daß die Kammer (52) aus einer gestuften Bohrung besteht und der Kolben (53) einen gestuften Durchmesser aufweist, wobei unterschiedliche Durchmesseranteile des Kolbens (53) verschiebbar abgedichtet sind gegenüber entsprechenden Teilen (52A, 52B) der Kammerbohrung, und daß das eine Ende des Kolbens mit einer konischen Nase (62) versehen ist, um in Bezug auf den Einlaß (27) aufzusitzen und, wenn der Kolben (53) für eine Gleitbewegung wie vorerwähnt freigegeben ist, um die wirksame Querschnittsfläche des Einlasses (27) der für eine Gasströmung als Funktion der Axialstellung des Kolbens (53) in der Kammer (52) zur Verfügung steht, zu steuern.

3. Atemgerät nach Anspruch 2, dadurch gekennzeichnet, daß der Kolben (53) einen Durchlaß (64) aufweist, dessen eines Ende durch den Kolben (53) sich zur Kammer (52) hin an einer Stelle öffnet, welche zwischen der konischen Nase (52) und der Gleitdichtung (64) kleineren Durchmessers des Kolbens (53) liegt und welcher sich axial durch den Kolben (53) erstreckt, um sich zur Kammer (52) hin an deren gegenüberliegendem Ende durch das gegenüberliegenden Ende des Kolbens (53) hindurch zu öffnen.

4. Atemgerät nach einem der Ansprüche 1 bis 3, dadurch gekennzeichnet, daß die Steuerteile umfassen ein manuell betätigbares Teil (61), das zwischen einer ersten Stellung, bei welcher es das gegenüberliegende Ende des Kolbens (53) berührt, um den Kolben in einer Stellung zu halten, bei welchem sein eines Ende (62) in Bezug auf den Kammereinlaß (27) aufsitzt, und einer zweiten im Abstand zur ersten Stellung bewegbar ist, in welcher der Kolben (53) für eine Gleitbewegung in der Kammer (52) freigegeben ist.

5. Atemgerät nach einem der vorhergehenden Ansprüche, dadurch gekennzeichnet, daß sowohl das erste (2) als auch das zweite erwähnte Schließventil (11) in einer gemeinsamen Ventilbaueinheit (13) vorgesehen sind, die einen Körper (13) mit einem Hauptgaszufuhrdurchlaß (23) aufweist, der zur Druckquelle (1) führt, wobei jedes der Schließventile (2, 11) am Körper (13) montiert ist und unabhängig voneinander mit dem Zufuhrdurchlaß (23) in Verbindung steht.

6. Atemgerät nach Anspruch 5, dadurch ge-

kennzeichnet, daß die Baueinheit (13) weiter umfasst ein Manometer (14) und/oder eine Druckentspannungsmittel (15) die am Körper (13) montiert sind und unabhängig voneinander und von den beiden Schließventilen (2, 11) mit dem Zufuhrdurchlaß (23) in Verbindung stehen.

7. Atemgerät nach Anspruch 5 oder 6, dadurch gekennzeichnet, daß der Körper von im wesentlichen rechteckiger ebener Form ist, bei dem das ersterwähnte Schließventil (2) an einer ersten Seite (12), das zweiterwähnte Schließventil (11) an einer zweiten Seite und das Manometer (14) und/oder das Druckentspannungsmittel (15) an einer dritten Seite montiert sind.

8. Atemgerät nach Anspruch 7, dadurch gekennzeichnet, daß sowohl eine Auslaßverbindung (41) vom ersterwähnten Schließventil (2), die zum Anschlußteil (6) führt und eine vom zweiterwähnten Schließventil (11) zum Anschlußventil (6) führende Auslaßverbindung (66) an der vierten Seite (18) des Körper (16) montiert sind.

9. Atemgerät nach Anspruch 8, dadurch gekennzeichnet, daß die Auslaßverbindung vom ersterwähnten Schließventil (2) die Form einer gewindemuffe (41) aufweist, auf welcher mittels eines Gewinderings (42) eine Druckmindervorrichtung (3) des ersten Strömungswegs (4) befestigt ist und daß die Auslaßverbindung vom zweiterwähnten Schließventil (11) die Form einer Buchse (66) aufweist, in welche ein muffenförmiges Verbindungsstück (67) des zweiten Strömungsweg (12) eingesetzt ist, wobei das Verbindungsstück (67) in dieser Buchse (66) gehalten wird durch überlappenden Eingriff mit einem randseitigen Teil des Rings (42).

10. Atemgerät nach einem der Ansprüche 5 bis 9, dadurch gekennzeichnet, daß die Ventilbaueinheit (13) an einer durch einen zylindrischen Behälter (1) gebildeten Gasdruckquelle befestigt ist und Teile des ersten (2) und des zweiterwähnten Schließventils (11) und der Manometer (14) und/oder das Druckentspannungsmittel (15) gänzlich innerhalb der projizierten Querschnittsfläche des zylindrischen Behälters (1) angeordnet sind.

## Revendications

1. Appareil respiratoire comportant: une source (1) de gaz respirable sous pression; un dispositif d'inhalation (6) adopté au visage d'un utilisateur; un premier circuit de débit (4) pour amener le gaz de la source (1) au dispositif d'inhalation (6), ce premier circuit de débit comportant au moins une soupape d'arrêt (2) et une soupape de débit ou de demande (15) agencée de manière à régler le débit de gaz respirable arrivant dans le dispositif d'inhalation (6) en régime d'utilisation normale; et un second circuit de débit (12) pour amener le gaz dispositif d'inhalation (6), indépendamment du régulateur de la soupape de débit

(5); cet appareil respiratoire étant caractérisé en ce que le second circuit de débit (12) comporte un système combiné (11) jouant le rôle de soupape d'arrêt et de régulateur de pression, comprenant un piston (53) monté à coulisse dans une chambre (52) qui est pourvue d'un orifice d'entrée (27) disposé à l'une des extrémités (52A) de la chambre (52), une extrémité (62) du piston (53) étant destinée à coopérer avec ledit orifice d'entrée (27) pour régler le débit de gaz passant à travers cet orifice; la chambre (52) comportant un orifice de sortie (66), disposé en aval de ladite extrémité (62) du piston (53); des moyens (64) étant prévus, pour permettre le passage du gaz entre ladite extrémité (52A) de la chambre (52) et l'extrémité opposée (52C) de cette chambre; l'extrémité opposée du piston (53) ayant une section transversale de surface utile supérieure à celle de la première extrémité (62) du piston; et des moyens (61) de commande manuelle pouvant être manoeuvrés de manière sélective, afin de faire passer le piston (53) à une position dans laquelle ladite extrémité (62) du piston se trouve appliquée de manière étanche sur l'orifice d'entrée (27) de la chambre, pour obturer le passage du gaz à travers cet orifice, ou au contraire afin de libérer le piston (53) pour lui permettre de se déplacer en coulissant dans la chambre (52) de manière à assurer le réglage de la pression du gaz qui passe dans le second circuit de débit (12).

2. Appareil respiratoire selon la revendication 1, dans lequel la chambre (52) présente des alésages étagés associés à des diamètres étagés du piston (53); les différentes parties du piston (53), correspondant à ces différents diamètres, pouvant coulisser de manière étanche, grâce à des joints (54, 55) dans les parties associées (52A, 52B) de la chambre (52); et en ce que ladite extrémité du piston est constituée par un pointeau conique (62), destiné à coopérer avec l'orifice d'entrée (27) qui joue le rôle d'un siège d'obturation via-à-vis du pointeau; le piston (53), lorsqu'il est libre de se déplacer comme indiqué plus haut pouvant ainsi coulisser dans la chambre pour assurer le réglage de la section de passage du gaz en regard de l'orifice d'entrée (27), qui varie en fonction de la position axiale du piston (53) dans la chambre (52).

3. Appareil respiratoire selon la revendication 2, dans lequel le piston (53) comporte un passage interne (64) qui traverse le piston, et dont une extrémité débouche dans la chambre (52), en un endroit situé entre le pointeau conique (62) et la joint d'étanchéité coulissant (54) de la partie de moindre diamètre du piston (53); le passage interne (64) du piston (53) s'étendant axialement dans le piston, pour déboucher par son autre extrémité dans la chambre (52), à l'endroit de l'extrémité opposée du piston (53).

4. Appareil respiratoire selon l'une quelconque des revendications 1 à 3, dans lequel les moyens de commande manuelle comportent un premier organe (51) de manoeuvre manuelle,

qui peut être déplacé, entre une première position dans laquelle cet organe est en appui contre l'extrémité opposée du piston (53), pour bloquer le piston dans une position telle que la première extrémité (62) du piston se trouve appliquée de manière étanche sur l'orifice d'entrée (27) de la chambre et une seconde position écartée de la première position, et telle que le piston (53) se trouve alors libre de se déplacer en coulissant dans la chambre (52).

5. Appareil respiratoire selon l'une quelconque des revendications précédentes, dans lequel la première soupape d'arrêt (2) et la seconde soupape d'arrêt (11) sont groupées dans un ensemble (13), qui comporte un corps (16) pourvu d'un passage principal (23) pour l'arrivée du gaz provenant de la source (1) de gaz sous pression; les deux soupapes d'arrêt (2, 11) étant montées dans le corps (16), de manière à communiquer indépendamment l'une de l'autre avec le passage d'arrivée (23).

6. Appareil respiratoire selon la revendication 5, dans lequel le système combiné des deux soupapes (13) comporte en outre un manomètre (15) et/ou un organe de décharge de sécurité (15) monté sur le corps (16); le manomètre et l'organe de décharge communiquant avec le passage d'entrée (23), indépendamment l'un de l'autre, et indépendamment des deux soupapes d'arrêt (2, 11).

7. Appareil respiratoire selon la revendication 5 ou la revendication 6, dans lequel le corps (16) présente en plan une forme sensiblement rectangulaire; la soupape d'arrêt (2) mentionnée en premier lieu est montée sur un premier côté (17) du corps; la soupape d'arrêt (11) mentionnée en second lieu étant montée sur un second côté du corps, et la manomètre éventuel (14) et/ou l'organe de décharge de sécurité (15) étant montés sur un troisième côté du corps.

8. Appareil respiratoire selon la revendication 7, dans lequel le quatrième côté (18) du corps (16) sert au montage d'un raccord de sortie (41) de la première soupape d'arrêt (2), pour desservir le dispositif d'inhalation (6) associé au visage de l'utilisateur, et au montage d'un raccord de sortie (66) de la seconde soupape d'arrêt (11) qui dessert également le dispositif d'inhalation (6) de l'utilisateur.

9. Appareil respiratoire selon la revendication 8, dans lequel le raccord de sortie de la première soupape d'arrêt (2) est constitué par un embout fileté (41), dans lequel est fixé, au moyen d'une bague fileté (42), un détendeur (3) du premier circuit de débit (4); et la raccord de sortie de la seconde soupape d'arrêt (11) est constitué par un trou (66), dans lequel est enfoncé un embout (67) du second circuit de débit (12); cet embout (67) se trouvant dans le trou (66) par la bordure de la bague fileté (42) qui déborde par-dessus une bordure de l'embout (67).

10. Appareil respiratoire selon l'une quelconque des revendications 5 à 9, dans lequel le système combiné (13) des deux soupapes

d'arrêt est monté sur une source de gaz sous pression constituée par un récipient cylindrique ou bouteille (1); et toutes les parties de la première soupape d'arrêt (2) et de la seconde soupape d'arrêt (11), ainsi que toutes les parties

5

du manomètre (14) et/ou de l'organe de décharge de sécurité (15), sont entièrement situées à l'intérieur d'un volume virtuel défini par la prolongement de la paroi cylindrique du récipient précité (1) de gaz sous pression.

10

15

20

25

30

35

40

45

50

55

60

65

9

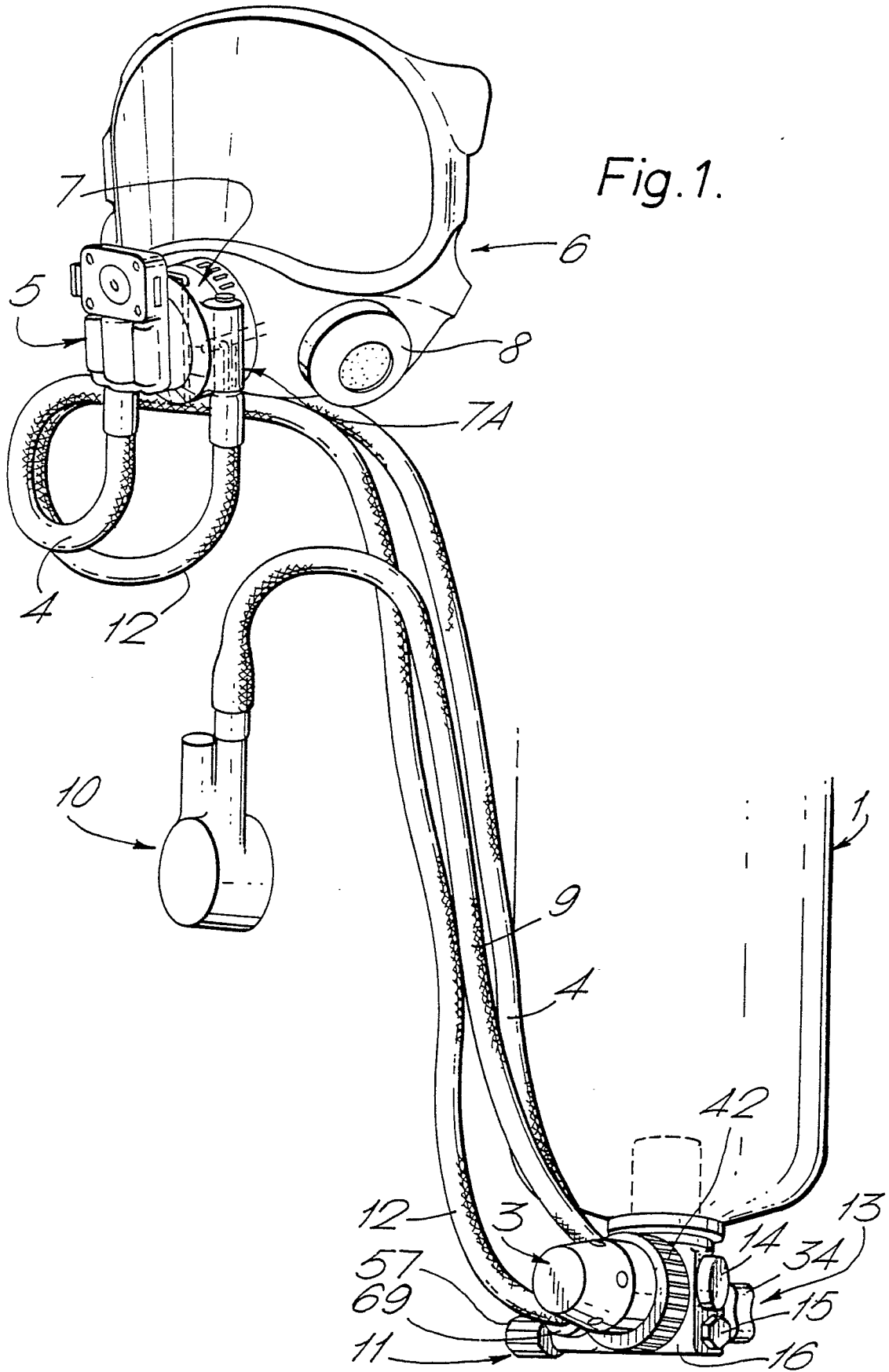
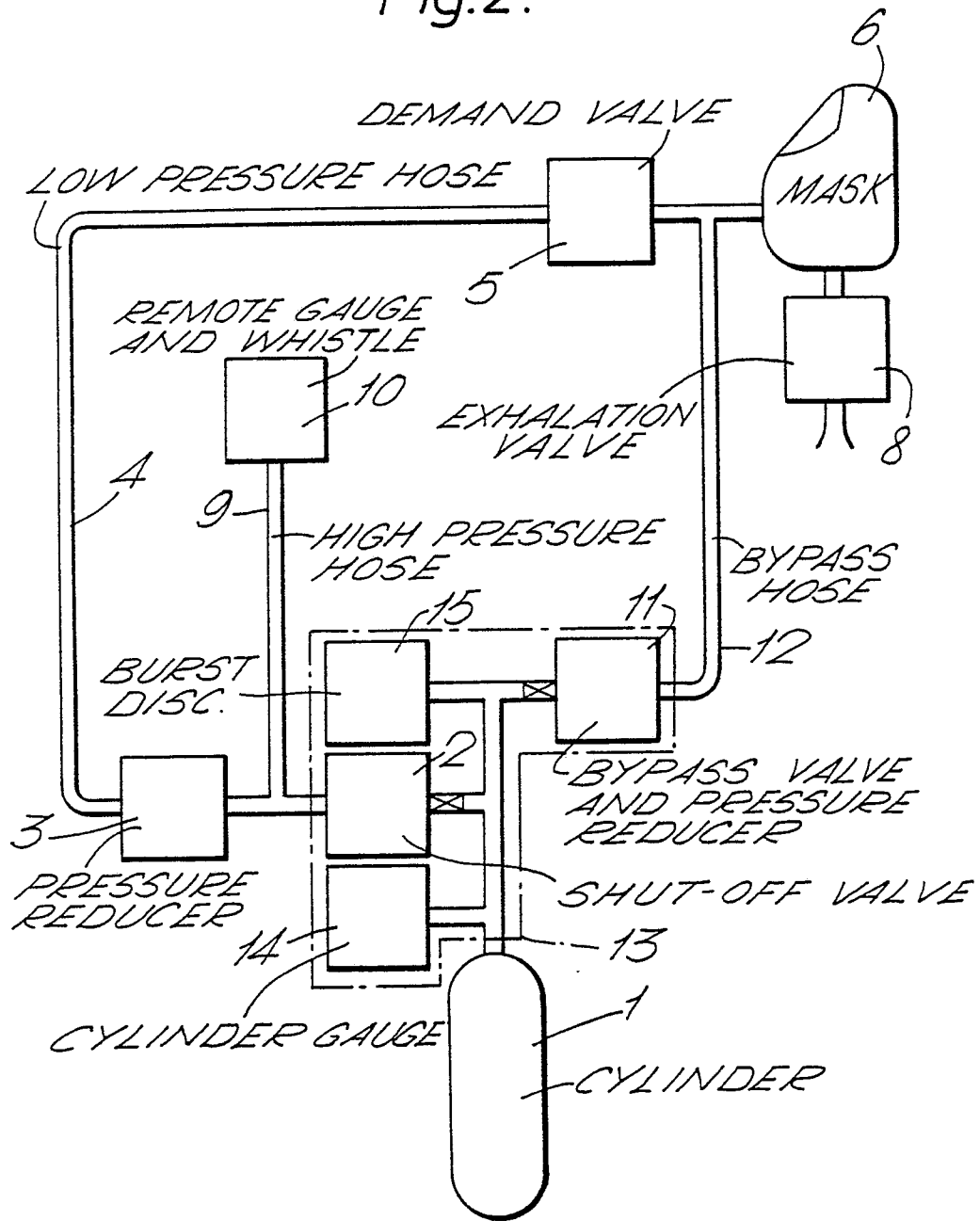

Fig. 1.

Fig.2.



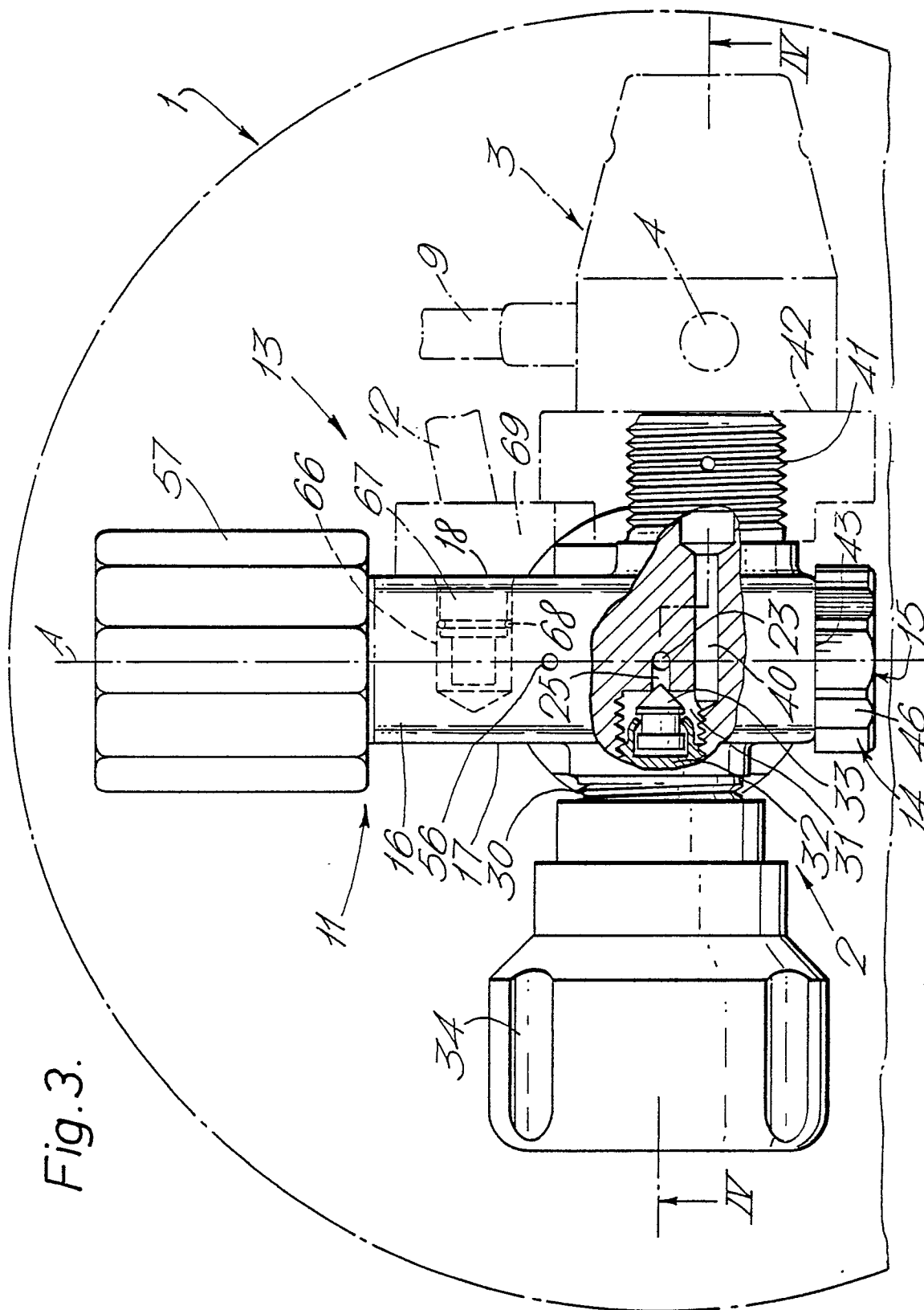

Fig. 3.

Fig. 4.

