

12 **EUROPEAN PATENT SPECIFICATION**

- 45 Date of publication of patent specification: **13.06.84** 51 Int. Cl.³: **F 24 F 7/02**
21 Application number: **81304827.9**
22 Date of filing: **16.10.81**

54 **Improvements relating to ventilators.**

- | | |
|---|--|
| <p>30 Priority: 16.10.80 GB 8033414</p> <p>43 Date of publication of application:
28.04.82 Bulletin 82/17</p> <p>45 Publication of the grant of the patent:
13.06.84 Bulletin 84/24</p> <p>84 Designated Contracting States:
AT BE CH DE FR LI LU NL SE</p> <p>56 References cited:
GB - A - 1 061 188
GB - A - 1 151 191
US - A - 2 492 242</p> | <p>73 Proprietor: COLT INTERNATIONAL HOLDINGS A.G.
Baarerstrasse 59
CH-6300 Zug (CH)</p> <p>72 Inventor: Burtenshaw, Raymond Alfred Frank
111, South Lane
Clanfield Hampshire (GB)</p> <p>74 Representative: Slight, Geoffrey Charles et al,
Graham Watt & Co. Riverhead
Sevenoaks Kent TN13 2BN (GB)</p> |
|---|--|

EP O 050 488 B1

Note: Within nine months from the publication of the mention of the grant of the European patent, any person may give notice to the European Patent Office of opposition to the European patent granted. Notice of opposition shall be filed in a written reasoned statement. It shall not be deemed to have been filed until the opposition fee has been paid. (Art. 99(1) European patent convention).

Description

This invention relates to ventilators and is concerned with powered, direct discharge ventilators, that is to say, ventilators which do not have a weathering cowl. In such a ventilator a self-weathering, non-return shutter assemblage is employed to close the exit from the extraction fan duct of the ventilator when the ventilator fan is not operating and thereby prevent weather entry through the ventilator and draught entering the building, as well as conserving heat in the building.

In our British Patent No. 1061188 we described some square outline forms of self-weathering, non-return shutter assemblages for upward discharge roof ventilators used for this purpose comprising non-return shutters hinged on axes radiating from the centre of the assemblage. These assemblages typically comprise four or more non-return shutters but another known arrangement of self-weathering non-return shutters of circular outline shape for this same purpose is described in U.S. Patent No. 2,668,491 and employs two non-return shutters only, hinged on parallel axes extending close to the centre of the assemblage so that the shutters move between their open and closed positions in opposite rotational directions, like butterfly wings. In all the known arrangements referred to, the non-return shutters are automatic in the sense that they are opened by the forced draught of the extraction fan and close under the action of gravity, possibly assisted by springs, when the extraction fan is stopped.

In order to shelter the non-return shutters from wind movement both when they are open and, more particularly when they are closed, a surrounding tubular windshield of matching cross-sectional shape is conventionally provided for example as described in U.S. Patent No. 2,668,491 or in our British Patent No. 1061188. A problem still arises under some conditions of roof mounting, however, in as far as the non-return shutters tend to open when the extraction fan is stationary and the non-return shutters are required to be closed, due to the action of wind blowing across the top of the windshield, sometimes in one particular direction.

The conventional windshield hitherto provided is necessarily somewhat tall. This, in itself, is open to objection for aesthetic reasons in so far as a roof mounted ventilator is, preferably, of low height so as not to stand out unduly against the sky. Because of the height of the windshield, however, the "wind-over" effect of wind blowing across the top of the windshield and tending to lift the non-return shutters by suction, when the shutters are required to be closed, is considerably increased. It would be possible to lock non-return shutters closed and to provide for automatic unlocking of the non-return shutters when the extraction fan

of the ventilator is started up and automatic locking of the shutters when the extraction fan is shut down. Such an arrangement would be complicated and expensive to provide however and also it would be subject to failure of the locking mechanism or the operating means for the locking mechanism.

It is known to provide, in a powered roof ventilator having a weathering cowl, a single non-return shutter for closing the exit from the extraction fan duct when the fan is not operating. Our British Patent No. 1,115,791 describes such an arrangement having a non-return shutter in the form of a flat disc or plate hinged or guided to float up on the airstream when the fan is started whilst maintaining a position generally parallel to that which it occupies in its fan duct closing position.

The use of such a single, non-return shutter in a powered, upward discharge roof ventilator would enable the height of the ventilator to be considerably reduced and, therefore, the "wind-over" effect above described. Tests made by the applicants have shown, however, that in this case, wind entry directly into the lowered wind shield of the ventilator can lift the non-return shutter from its closed position, particularly if the ventilator is mounted on a sloping roof facing the wind direction.

In order to maintain the non-return shutter or shutters closed in a powered, upward discharge roof ventilator without resorting to complicated locking arrangements, the present invention proposes to employ a wind effect.

U.S. Patent No. 2,492,242 describes ventilating apparatus for a building having a wind controlled ventilating flap which is closed by the action of wind on a windward side of the ventilator to prevent air entering under a valve cap of the ventilator. Wind blowing through the ventilator and across the top of the valve cap then draws air from under the valve cap and out of the building through a ventilation opening having a corresponding wind controlled flap on the opposite side of the ventilator, the suction thereby created holding the windward flap closed.

According to the present invention, a powered, direct discharge ventilator comprising a base defining a ventilation opening, an extraction fan carried by the base, a self-weathering non-return shutter means for closing the ventilation opening when the extraction fan is not operating and a windshield carried from the base and surrounding the shutter means is characterised by a wind deflector or wind deflectors mounted so as to extend at least partially above the upper edge of the windshield when the ventilator is mounted in a horizontal, flat roof position to deflect wind blowing in at least one direction across the top of the windshield downwardly into the windshield to assist in holding the non-return shutter means closed when the extraction fan is not operating.

5

10

15

20

25

30

35

40

45

50

55

60

65

The wind deflector or wind deflectors of the invention may deflect wind blowing in at least one general direction across the top of the windshield downwardly into the windshield onto the non-return shutter or shutters to hold the non-return shutter or shutters closed when the shutter or shutters are in their closed position.

In order to deflect wind blowing from any direction, or to accommodate any mounting orientation of the ventilator itself, a ring-form wind deflector is conveniently provided, mounted above or in the top of the windshield to turn air blowing over the top of the windshield in any direction into the windshield in a generally downwardly directed stream.

Specific embodiments of the present invention will now be described by way of example, and not by way of limitation, with reference to the accompanying drawings in which:—

Figure 1 is a side elevation of a powered, upward discharge roof ventilator according to the present invention;

Figure 2 is a plan view of the ventilator;

Figure 3 is a cross-section on line 3—3 in Figure 2;

Figure 4 is a partial, cross-sectional side elevation of a further powered, upward discharge ventilator according to the present invention; and

Figure 5 is a plan view of the ventilator shown in Figure 4.

With reference now to the accompanying drawings, and first to Figures 1 to 3, the ventilator there shown is assumed to be mounted on a flat roof with the axis C of rotation of its extraction fan K extending vertically. The ventilator comprises a base B having a square base flange 10 intended to be flashed to the roof and a circular upstanding wall 11 defining a ventilation opening or throat 12 forming an extraction fan duct having a bell mouthed entry portion 13. Carried from the base flange 10 by bracket F is a shallow, inverted, frusto conical dish-form member D having a central, circular opening 15 in its floor. The upper edge portion of the wall 11 is received in the opening 15 with a small clearance so that a water drainage gap 16 is formed to allow rain water which enters the dish-form member D to drain out of the dish-form member onto the outside of the roof. The wall 11 penetrates upwardly into the dish-form member D to a small extent only, sufficient to prevent water entering the dish-form member D and running down onto the floor of the member, passing into the throat 12 of the ventilator and thence into the building being ventilated.

The fan K is carried by radial arms A bolted to the base B by the same bolts and nuts as are used to secure the brackets F to the base B, the inner radial ends of the arms A being fixed to the fan motor casing. The fan impeller L is of the axial flow type and runs with a minimum

clearance in an upper, cylindrical portion of the duct 12 of the ventilator.

When the fan is operated, the upwardly discharging stream of air generated through the duct 12 of the ventilator prevents the entry of rain into the duct 12 of the ventilator and therefore into the building.

To prevent the entry of rain through the duct 12 into the building, and the down-draught of air into the building, when the fan is not operating, as well as for conserving heat in the building when the fan is not operating, a self-weathering non-return shutter S is provided to close the exit from the extraction fan duct 12.

The non-return shutter S is of circular outline and is formed by a single disc or plate shaped like a hat in cross-section, the brim edge of which rests upon a number of circumferentially spaced apart rubber stops T carried in the floor of the member D such that the non-return shutter S is closely spaced above the top edge of the wall 11 and covers over and closes the opening defined by the wall 11 when the non-return shutter S is in its closed position as shown in full line in Figure 3. In this position, the non-return shutter S shelters the extraction fan duct 12 from the entry of rain and snow and the slope of the upper surface of the non-return shutter S drains rain water over the outside of the upper edge portion of the wall 11 into the dish-form member D, from which the water drains downwardly through the gap 16 previously described onto the outside of the roof.

A wire bird-guard or grid G is mounted on top of the member D. The grid is composed of an array of horizontally disposed circular wire hoops 14 of progressively smaller diameter held in vertically spaced apart relationship with respect to one another by upwardly extending interconnecting spring wires 17 having cranked lower end portions 17' sprung through individual holes in the wall of the dish-form member D and upper end portions 17'' extending at first inwardly over the dish-form member D and then curving downwardly and terminating in short downwardly and outwardly extending portions 17''' which engage under the lower and radially inner edge of an annular, ring-form wind deflector W of circular outline to support the deflector co-axially with respect to the axis C. The deflector W has an under-surface WS which is inwardly and downwardly curved from its upper and radially outer edge W1 to its lower and radially inner edge W2 and acts to turn air blowing across the top of the member D downwardly into the hollow interior of the member D and onto the top surface of the non-return shutter S in a downwardly directed stream. The member D acts as a windshield to shelter the non-return shutter S against the action of wind to some extent when the non-return shutter is closed, the member D being, nevertheless, of an acceptably low height to meet aesthetic

requirements. However, the member D by itself, is not capable of preventing unwanted opening of the non-return shutter S under all wind conditions. The provision of the wind deflector W meets the problem because the downwardly directed stream of air created by the wind deflector W acts to assist in holding the non-return shutter S in its closed position to which it is always returned by its own weight when the extraction fan is shut down. Thus, wind entering the member D directly is prevented from lifting the shutter S and any "wind-over" suction effect on the shutter due to wind blowing across the top of the member D is eliminated by the action of the wind deflector W.

The non-return shutter S is carried by a pair of hinge arms H to float up on the airstream discharged through the fan duct 12 when the extraction fan K is operating, to take up the position shown in chain-dotted outline in Figure 1 in which the upper surface of the brim portion of the non-return shutter S is pressed against the radially inner, lower edge W2 of the deflector W and the central "crown" portion of the shutter S is entered through the opening of the ring-form deflector W.

The hinge arms H extend parallel to one another over their largest extent and define horizontally extending pivot axes N1 and N2 at their two ends respectively, the arms H being pivoted to the non-return shutter S on the side of its centre of gravity CG remote from their other ends, the other ends of the arms H being pivoted to a horizontal pivot rod P carried by an adjacent pair of the wires 17.

When the ventilator is shut down, and the fan K ceases to rotate, the non-return shutter S swings closed under the action of gravity. In order to prevent the non-return shutter tilting and the edge of the shutter entering the upper end of the duct 12 as the shutter swings shut, thereby jamming the shutter in a tilted position, a flexible strap R is provided (see Figure 1) tying the edge of the shutter S at a point midway between the hinge arms H on the side of the centre of gravity of the shutter remote from the hinge axis defined between the hinge arms and the shutter, to the bird-guard G.

The dish-form member D is of upwardly divergent shape from its lower end to its upper end to allow air to be discharged upwardly and outwardly from the throat of the ventilator between the edge of the non-return shutter S and the upper edge of the member D when the non-return shutter S is in its open position. Figure 3 shows, on the right hand side, in chain-dotted outline, an alternative shape for the wall of the dish-form member D in which the member is upwardly divergent from its lower end towards its upper end, the upper end portion of the member being straight, i.e. cylindrical and vertically disposed in the present example.

The gap 16 may be sealed with an elastomeric sealing ring, drainage holes being

provided instead in the floor of the member D. Preferably, five such drainage holes are provided, one at each side of the stop T shown at the right hand side in Figure 1, one adjacent the stop T shown at the left hand side in Figure 1 and the other two at intermediate positions and respectively at opposite sides of the member D.

The pair of drainage holes at the right hand side in Figure 1 accommodate the additional flow of rainwater when the ventilator is mounted on a pitched roof for example. In this case, the hinge rod P is positioned horizontally down slope towards the horizontal edge of the base 10, the ventilator then sloping from left to right in Figure 1.

To ensure that the shutter S always tends to close gravitationally when the fan is shut down, despite the slope angle at which the ventilator is mounted, the centre of gravity CG of the shutter is positioned such that it always lies to that side of the plane of the axes N1, N2 adjacent the ventilator base 10.

This applies even for a vertical wall mounted position of the ventilator at 90° to the horizontal with the hinge rod P horizontal and positioned adjacent the bottom horizontal edge of the base 10.

The fan K has an "inside-out" motor of small vertical height so as to be generally within the base 10 of the fan, as shown in Figure 3 and a wire mesh safety guard Z is provided, covering the mouth of the entry portion 13 to the ventilation opening.

With reference now to figures 4 and 5, in this further embodiment of ventilator of which parts only are shown in Figure 4, parts corresponding with parts already described are indicated by corresponding reference letters or reference numerals. The ventilator is generally as described in our British Patent No. 1061188 and has an upwardly divergent, square-sectioned windshield D' surrounding and sheltering a "four-square" non-return shutter assemblage one of the hinged shutters S' of which is illustrated swung open to a vertical position of maximum height in which its upper edge is at a level above the top of the windshield D'. The shutters S' do not normally swing open to this position when the extraction fan is started, but instead float up at some intermediate angle so as to assume an inclined position in which they are supported by the discharging air stream and, in fact, stops are usually provided preventing the non-return shutters S' opening to their maximum height. Mounted above the top of the windshield D' so as to extend inwardly of its upper edge, and conveniently above the maximum height of the shutters S' to facilitate maintenance work on the ventilator, is an annular, ring-form wind deflector W' of square form outline composed of four air deflectors 21, one mounted along each of the four sides of the windshield D' by means of a pair of mounting brackets 22. Each

deflector 21 has a plane, horizontally directed upper edge stiffening portion 21*b* followed by a plane, downwardly and inwardly directed operative portion 21*a* followed by a plane, horizontally directed lower edge stiffening portion 21*c* and the deflectors abut one another at the four corners of the windshield D' so as to form a ring of generally square inverted frusto-pyramidal shape.

In use of the ventilator, when the extraction fan (not shown) is not operating, the shutters S' normally assume their closed position weathering the exit from the extraction fan duct and preventing downdraughts into the building. Under high wind conditions, any tendency for wind blowing across the top of the windshield D' to create a suction effect or updraught inside the windshield, thereby lifting the shutters S', is prevented in as far as the wind striking one or more of the inclined portions 21*a* of the deflectors 21 is directed downwardly into the inside of the windshield. The downwardly directed air stream may impinge upon the shutters S' positively to assist in holding them closed.

It will be appreciated that it is not necessary for the deflectors 21 to abut one another at the corners of the windshield. Gaps could be left at the corners if desired. Furthermore, only one of the deflectors 21 or, say, an adjacent pair of the deflectors 21 only might be provided, to deal with a particular installation problem, caused by a prevailing wind. In the case of the powered, upward discharge ventilator having a circular sectioned windshield D first described with reference to Figures 1 to 3, a circular wind deflector W is more conveniently used but a part circular wind deflector W could be used mounted above the windshield D or inside the top of the windshield D so as to extend above the top of the windshield to deal with a prevailing wind condition. Thus, it will be appreciated that the wind deflector or deflectors described may extend into the top of the windshield if desired.

The non-return shutter S or shutters S' may be made of translucent material.

Claims

1. A powered, direct discharge ventilator comprising a base (B) defining a ventilation opening (12), an extraction fan (K) carried by the base, a self-weathering non-return shutter means (S;S') for closing the ventilation opening when the extraction fan is not operating and a windshield (D;D') carried from the base and surrounding the shutter means, characterised by a wind deflector W or wind deflectors (W') mounted so as to extend at least partially above the upper edge of the windshield when the ventilator is mounted in a horizontal, flat roof position to deflect wind blowing in at least one direction across the top of the windshield downwardly into the windshield to assist in

holding the non-return shutter means closed when the extraction fan is not operating.

2. A ventilator as claimed in claim 1 in which the non-return shutter means comprises a single, non-return shutter (S) mounted to float-up on the airstream discharged by the extraction fan when the extraction fan is operating whilst maintaining a position generally parallel to that which it occupies when the non-return shutter means is closed.

3. A ventilator as claimed in claim 2 in which the single, non-return shutter opens to a position above the upper edge of the windshield and the wind deflector or deflectors are also positioned entirely above said upper edge.

4. A ventilator as claimed in claim 3 in which the windshield is upwardly divergent from its lower to its upper end.

5. A ventilator as claimed in claim 3 in which the windshield is upwardly divergent from its lower end towards its upper end, the upper end portion of the windshield being straight.

6. A ventilator as claimed in any preceding claim 2 to 5 in which the single, non-return shutter is mounted on a pair of arms (H) pivoted to the shutter on a hinge axis (N2) disposed to one side of the centre of gravity (CG) of the shutter, and a flexible strap (R) supports the shutter between the arms towards its edge on the other side of the centre of gravity of the shutter when the shutter is in its closed position.

7. A ventilator as claimed in any preceding claim 2 to 5 in which the single, non-return shutter is pivotally mounted about a pair of parallel pivot axes (N1, N2) so as to swing between open and closed positions and the centre of gravity (CG) of the shutter is positioned such that it always lies to that side of the plane of said pivot axes adjacent the ventilator base.

8. A ventilator as claimed in any preceding claim in which a single, annular wind deflector is provided.

9. A ventilator as claimed in claim 6 in which the wind deflector is curved in a cross-sectional shape.

50 Patentansprüche

1. Kraftbetriebene Direktausstoß-Entlüftungsvorrichtung, mit einem eine Entlüftungsöffnung (12) begrenzenden Sockel (B), einem vom Sockel abgestützten Abzuggebläse (K), einer selbstschließenden Sperrabdeckung (S;S') zum Schließen der Entlüftungsöffnung bei nicht laufendem Abzuggebläse und einem vom Sockel getragenen und die Abdeckung umgebenden Windschild (D;D'), gekennzeichnet durch einen Windabweiser (W) oder mehrere Windabweiser (W') in einer Anbringung zur zumindest teilweisen Erstreckung oberhalb des oberen Randes des Windschildes, wenn die Entlüftungsvorrichtung in einer horizontalen Flach-

dachstellung montiert ist, um oben über den Windschild in zumindest einer Richtung wehenden Wind nach unten in den Windschild abzulenken, um bei nicht laufendem Abzuggebläse das Geschlossenhalten der Sperrabdeckung zu unterstützen.

2. Entlüftungsvorrichtung nach Anspruch 1, dadurch gekennzeichnet, daß die Sperrabdeckung eine einzige, derart angebrachte Sperrklappe (S) aufweist, daß sie auf dem bei laufendem Abzuggebläse aus letzterem ausgestoßenen Luftstrom unter Beibehaltung einer allgemein parallelen Stellung zu derjenigen, die sie bei geschlossener Sperrabdeckung einnimmt, aufschwebt.

3. Entlüftungsvorrichtung nach Anspruch 2, dadurch gekennzeichnet, daß die einzige Sperrklappe sich zu einer Stellung oberhalb des oberen Randes des Windschildes offen bewegt und der oder die Windabweiser ebenfalls völlig oberhalb des oberen Randes angeordnet ist bzw. sind.

4. Entlüftungsvorrichtung nach Anspruch 3, dadurch gekennzeichnet, daß der Windschild von seinem unteren zu seinem oberen Ende nach oben divergiert.

5. Entlüftungsvorrichtung nach Anspruch 3, dadurch gekennzeichnet, daß der Windschild von seinem unteren Ende in Richtung zu seinem oberen Ende hin nach oben divergiert, wobei der obere Endbereich des Windschildes gerade ausgebildet ist.

6. Entlüftungsvorrichtung nach einem der vorhergehenden Ansprüche 2 bis 5, dadurch gekennzeichnet, daß die einzige Sperrklappe an zwei Armen (H) angebracht ist, die an einer zu einer Seite des Schwerpunktes (CG) der Klappe angeordneten Schwenkachse (N2) an die Klappe angelenkt sind, und ein flexibler Gurt (R) die Klappe zwischen den Armen zu ihrem Rand hin an der anderen Seite des Schwerpunktes der Klappe abstützt, wenn sich diese in ihrer geschlossenen Stellung befindet.

7. Entlüftungsvorrichtung nach einem der vorhergehenden Ansprüche 2 bis 5, dadurch gekennzeichnet, daß die einzige Sperrklappe um zwei parallele Schwenkachsen (N1, N2) für ein Verschwenken zwischen einer offenen und einer geschlossenen Stellung drehbar gelagert ist und der Schwerpunkt (CG) der Klappe so angeordnet ist, daß er stets auf jener Seite der Ebene der Schwenkachsen liegt, die dem Sockel der Entlüftungsvorrichtung benachbart ist.

8. Entlüftungsvorrichtung nach einem der vorhergehenden Ansprüche, dadurch gekennzeichnet, daß ein einziger, ringförmiger Windabweiser vorgesehen ist.

9. Entlüftungsvorrichtung nach Anspruch 6, dadurch gekennzeichnet, daß der Windabweiser eine gekrümmte Querschnittsform aufweist.

Revendications

1. Ventilateur motorisé à évacuation directe

comprenant une base (B) définissant une ouverture de ventilation (12), un ventilateur d'aspiration (K) supporté par la base, des moyens à volets de retenue autoprotecteurs (S; S') pour fermer l'ouverture de ventilation lorsque le ventilateur d'aspiration n'est pas en service, et un pare-vent (D; D') supporté à partir de la base et entourant les moyens à volets, caractérisé par un déflecteur de vent (W) ou des déflecteurs de vent (W') montés de manière à s'étendre au moins partiellement au-dessus du bord supérieur du pare-vent lorsque le ventilateur est monté en une position horizontale et plane du toit pour dévier le vent soufflant dans au moins une direction sur le sommet du pare-vent vers le bas dans le pare-vent pour aider à maintenir les moyens à volets de retenue fermés lorsque le ventilateur d'aspiration n'est pas en service.

2. Ventilateur selon la revendication 1, caractérisé en ce que les moyens à volets de retenue comprennent un volet de retenue unique (S) monté de manière à flotter sur le courant d'air évacué par le ventilateur d'aspiration lorsque le ventilateur d'aspiration est en service tout en conservant une position sensiblement parallèle à celle qu'il occupe lorsque les moyens à volets de retenue sont fermés.

3. Ventilateur selon la revendication 2, caractérisé en ce que le volet de retenue unique (S) s'ouvre en une position située au-dessus du bord supérieur du pare-vent (D—D') et en ce que le déflecteur (W) ou les déflecteurs (W') sont également positionnés entièrement au-dessus dudit bord supérieur.

4. Ventilateur selon la revendication 3, caractérisé en ce que le pare-vent (D,D') diverge vers le haut de son extrémité inférieure vers son extrémité supérieure.

5. Ventilateur selon la revendication 3, caractérisé en ce que le pare-vent (D,D') diverge vers le haut de son extrémité inférieure vers son extrémité supérieure, la partie d'extrémité supérieure du pare-vent étant droite.

6. Ventilateur selon l'une des revendications 2 à 5, caractérisé en ce que le volet de retenue (S) est monté sur une paire de bras (H) pivotant sur le volet sur un axe de pivotement (N2) disposé d'un côté du centre de gravité (CG) du volet, et en ce qu'une liaison flexible (R) supporte le volet (S) entre les bras (H) vers son bord situé de l'autre côté centre de gravité du volet lorsque le volet occupe sa position fermée.

7. Ventilateur selon l'une des revendications 2 à 5, caractérisé en ce que le volet de retenue unique (S) est monté pivotant autour d'une paire d'axes de pivotement parallèles (N1, N2) de manière à basculer entre des positions ouverte et fermée, et le centre de gravité (CG) du volet est positionné de manière à ce qu'il soit toujours situé par rapport au plan des axes de pivotement (N1, N2) du côté adjacent à la base du ventilateur.

65

6

8. Ventilateur selon l'une des revendications précédentes, caractérisé en ce qu'il comporte un déflecteur de vent annulaire.

9. Ventilateur selon la revendication 6, caractérisé en ce que la forme en section du déflecteur de vent est courbe.

5

10

15

20

25

30

35

40

45

50

55

60

65

7

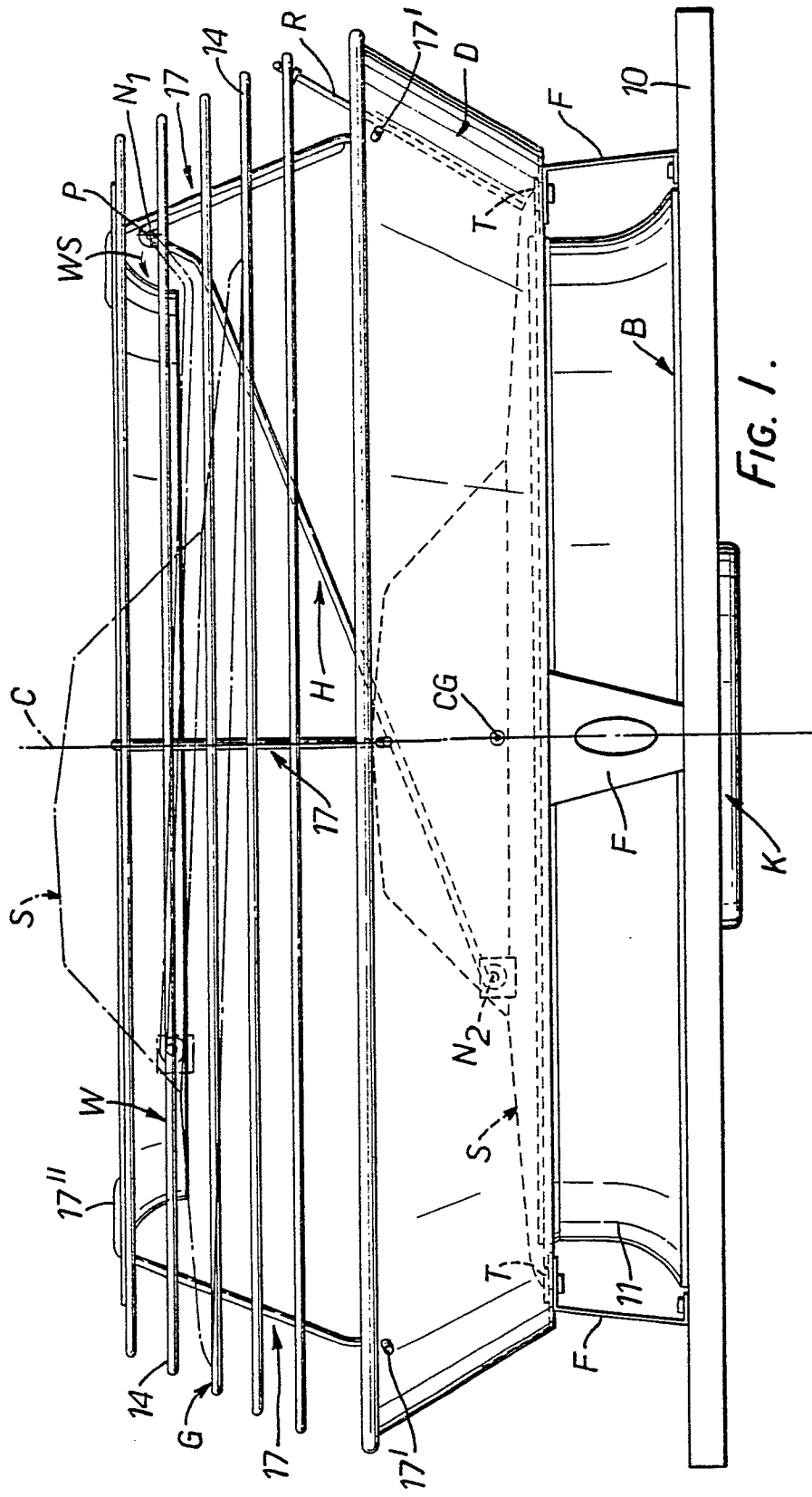

FIG. 1.

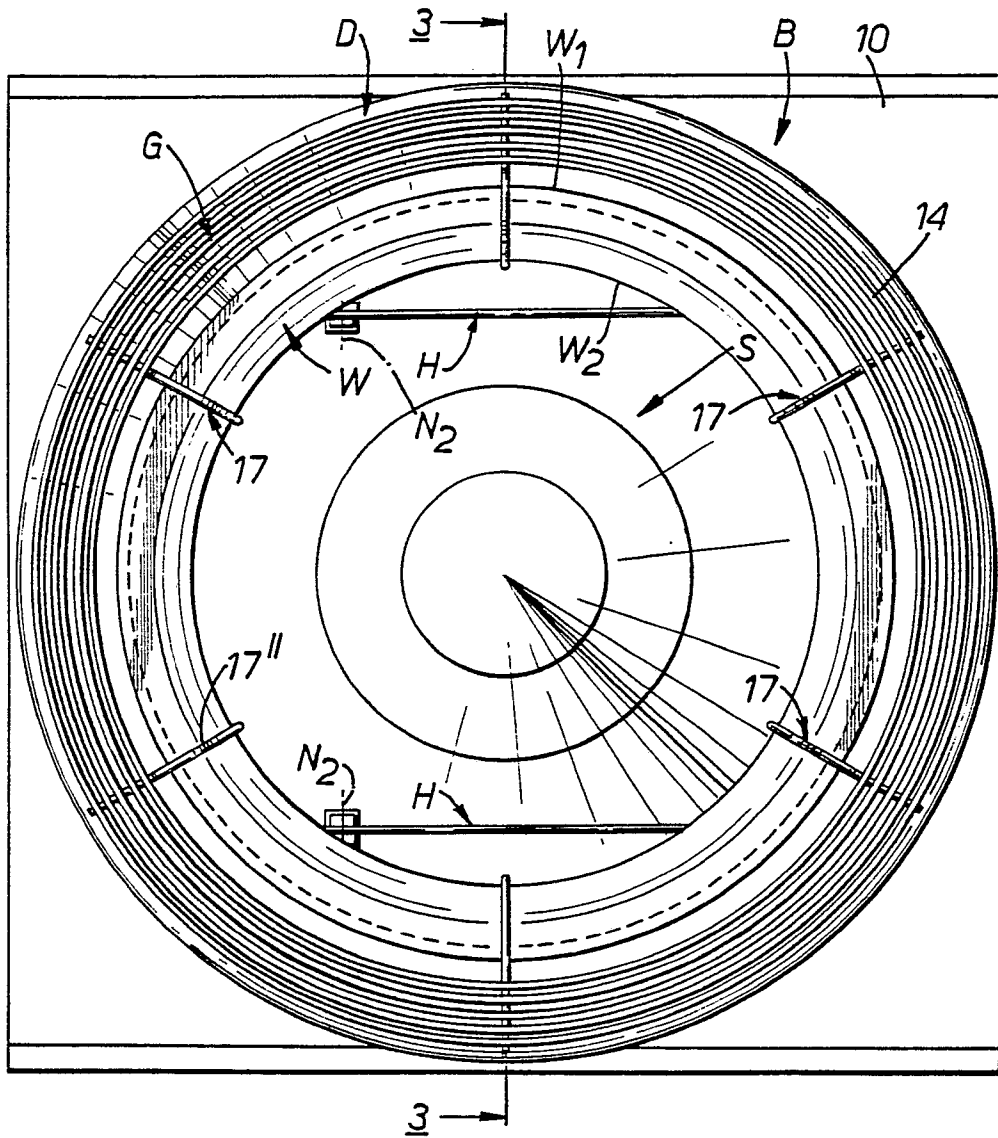

FIG. 2.

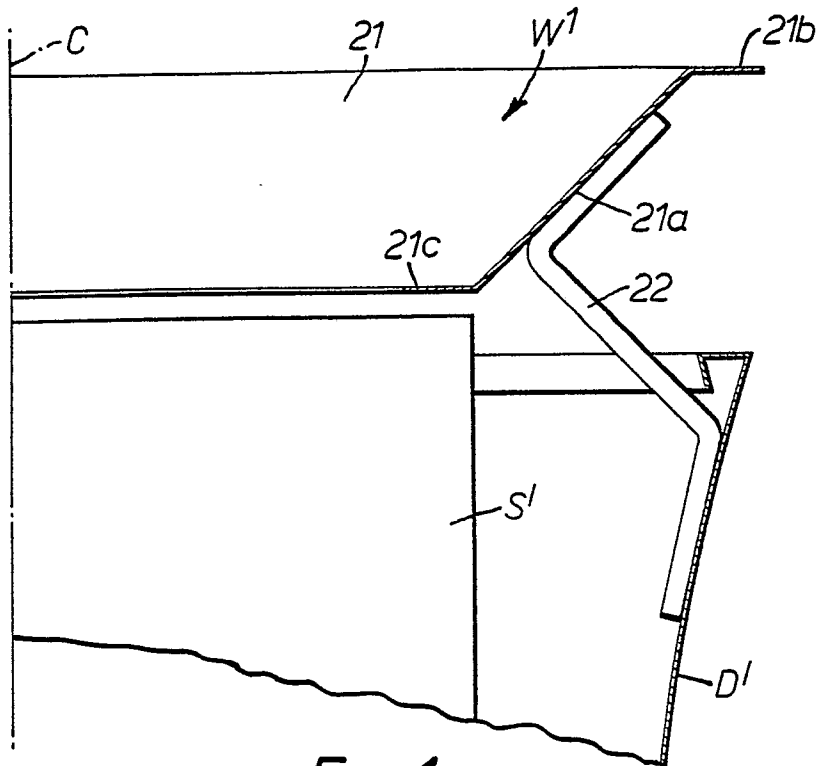

FIG. 4.

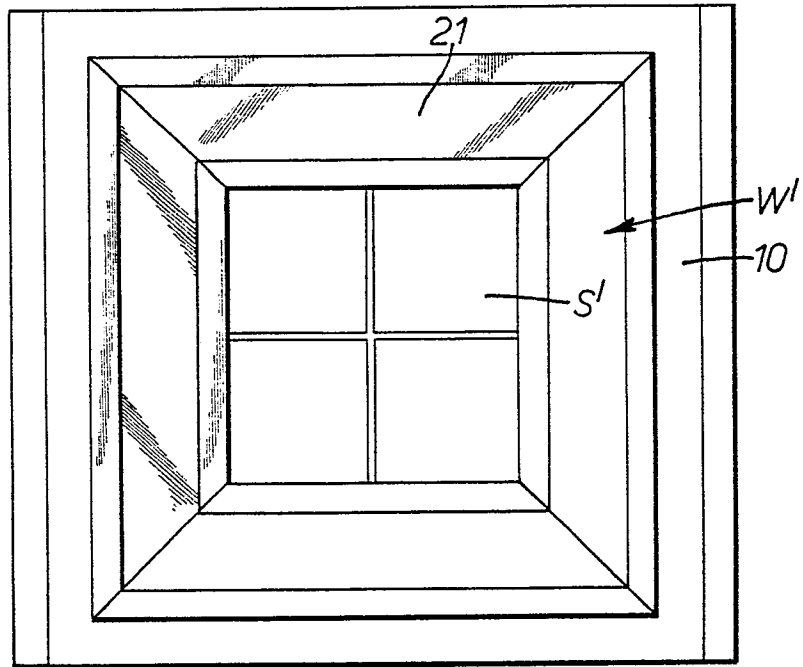

FIG. 5.