

**EUROPEAN PATENT SPECIFICATION**

- ④ Date of publication of patent specification: **10.12.86**      ⑤ Int. Cl.<sup>4</sup>: **B 25 B 23/147**  
⑥ Application number: **82301895.7**  
⑦ Date of filing: **08.04.82**

⑧ **Motor driven power tool.**

⑨ Priority: **13.04.81 GB 8111620**

⑩ Date of publication of application:  
**27.10.82 Bulletin 82/43**

⑪ Publication of the grant of the patent:  
**10.12.86 Bulletin 86/50**

⑫ Designated Contracting States:  
**AT BE CH DE FR IT LI LU NL SE**

⑬ References cited:  
**GB-A-1 457 496**

⑭ Proprietor: **DESOUTTER, LIMITED**  
**319, Edgware Road**  
**Colindale London NW9 6ND (GB)**

⑮ Inventor: **Brown, Simon Patrick**  
**70, New Road Digswell**  
**Welwyn Hertfordshire (GB)**  
Inventor: **Okunor, Joshua Nee Adjah**  
**84, Buckingham Drive Stopsley**  
**Luton Bedfordshire (GB)**

⑯ Representative: **Higgins, Michael Roger et al**  
**Marks & Clerk 57/60 Lincoln's Inn Fields**  
**London WC2A 3LS (GB)**

Note: Within nine months from the publication of the mention of the grant of the European patent, any person may give notice to the European Patent Office of opposition to the European patent granted. Notice of opposition shall be filed in a written reasoned statement. It shall not be deemed to have been filed until the opposition fee has been paid. (Art. 99(1) European patent convention).

## Description

This invention relates to a motor driven power tool, e.g. a screwdriver and more particularly but not exclusively to an electric motor driven power tool.

It is known, for example from GB—A—1457496, to provide a power tool comprising a casing having a tool holder and a motor mounted therein, a torque sensitive device between the motor and the tool holder and switch means operable to cut off the motor when a torque above a predetermined value is transmitted across the device.

The present invention is characterised in that the switch means includes a Hall effect device, comprising a stationary Hall effect element and a magnet movable relative to the Hall effect element when the torque transmitted across the torque sensitive device exceeds said predetermined value.

The Hall effect device can provide a low inertia non-contact arrangement for cutting off the motor when the torque exceeds said predetermined value.

Preferably, the torque sensitive device comprises torque sensitive device parts movable axially relative to each other when the torque exceeds said predetermined value to move the magnet relative to the Hall effect element.

Advantageously, the Hall effect device is interposed between the motor and the torque sensitive device.

The motor and the torque sensitive device may be axially spaced apart with the Hall effect device adjacent to the motor and in this case, an elongate actuating member, e.g. a push rod, couples the torque sensitive device to the magnet of the Hall effect device. A gear-box may be interposed between the motor and torque sensitive device, in which case the elongate actuating member will extend through the gear-box.

Preferably, the motor is an electric motor. A switch may be provided for reversing the direction of the motor.

In one embodiment, the switch means, including the Hall effect device, may be operable to energise the motor in response to axial movement of the torque sensitive device towards the motor. In another embodiment, the motor may be energised by a switch mounted on the body of the tool.

The invention will now be more particularly described, by way of example, with reference to the accompanying drawings, wherein:—

Figure 1 is a longitudinal section through one embodiment of a power tool according to the invention and illustrated in a datum position, and

Figure 2 is a block diagram of the electrical circuit for operating the motor of the tool shown in Figure 1.

Referring to the drawing, there is shown therein a power tool 10, in the form of a screwdriver, which is driven by an electric motor 11. The tool 10 has a tubular casing 12 which contains the motor drivingly connected to a shaft 13 *via* a gear

box 14. A clutch has a driving member 15, which is integral with the shaft 13 so as to be rotated therewith, and a driven member 16, integral with a tool holder 17 which is mounted in a bearing sleeve 18 fixed in one end of the casing 12 and is adapted to releasably locate a screwdriver bit (not shown). One clutch member is constituted by a boss 20 at the rear end of the driven member 16 and the other clutch member by balls 21 carried in radial passages formed in the forward end of the driving member 15. The balls are biased by means of a spring-loaded sleeve 22 mounted on the surface member 15 and having a frusto-conical end surface 23 which engages the balls. Compression spring 24 pushes the sleeve 22 over the balls and the end surface 23 pushes them in towards the axis of the clutch.

The end of the compression spring 24 remote from the sleeve 22 abuts against an annular block 25 keyed to the shaft 13 in such a manner that its position along the axis of the shaft 13 can be adjusted in order to vary the compression in the spring 24. The other end of the spring 24 abuts against an outwardly extending flange of collar 26 which is mounted on the shaft so as to be axially slidable therealong. A latch sleeve 27 is also mounted on the shaft 13 so as to be axially slidable therealong and is biased towards the rear end of the collar 26 by a compression spring 28. A thrust bearing 29 is interposed between the collar 26 and the sleeve 22 so that the sleeve 22 can rotate freely relative to the spring 24 which is under compression and which engages the block 25 keyed as aforesaid to the shaft 13. The sleeve 22 is free to rotate about the driving member 15 so that as the balls 21 are cammed outwards as hereinafter more fully explained, they will rotate about axes parallel with the tool axis so that there is no sliding between the ball surface and either of the surfaces with which the balls are in contact.

The shaft 13 is splined to the output member of the gearbox 14 so as to be axially slidable relative thereto. A compression spring 30 urges the shaft 13 and hence driving and driven members 15 and 16 respectively forwards until a shoulder 31 on the driven member 16 engages the bearing sleeve 18. A push rod 32, which operates the motor as explained hereinafter extends through the gearbox 14, and into the shaft 13 where it engages a latch bolt 33. The shaft 13 has radial passages which accommodate balls 34. The balls 34 normally project into an annular recess in the latch bolt 33 where they are retained by the latch sleeve 27, but the sleeve 27 and collar 26 define an annular groove 35 which when aligned with the passages accommodating the balls 34 as hereinafter described allows the balls 34 to move radially away from the axis of the shaft.

The boss 20 is of generally square cross-section but each face has a detent recess adjacent to the trailing edge of the face when viewed in the direction of forward rotation of the boss 20. The purpose of these detent recesses will be explained hereinafter.

The rear end of the push rod 32 has a piston 36

attached thereto. The rear face of the piston 36 bears against a permanent magnet 37 which together with the piston 36 is axially slidably mounted in a hollow non-magnetic transmission shaft 38 which drivably connects the electric motor 11 to a pinion 39 at the input end of the gearbox 14. A non-magnetic permanent magnet return spring 40 is disposed within the transmission shaft 38 between the magnet 37 and a spacer 41. Surrounding the transmission shaft and fixed against angular movement relative to the casing 12 is an axially adjustable non-magnetic carrier 42 for a Hall effect element 43.

As shown in Figure 2, the Hall effect element 43 connected to a Hall effect enable switch 44 which is in turn connected to a power switching circuit 45 operable to supply power to the motor 11. The tool is provided with a touch switch pad 46 which is activated by the pressure of a conductive mass of significant size in contact with the pad. An output signal of the touch switch is conditioned by a conditioning circuit 47 to provide a digital signal fed to a phase splitter 48 which in turn sets the power switching circuit into a forward or reverse state.

In operation, the screwdriver bit is located in the head of the screw and sufficient thrust is applied to compress the springs 30 & 40. The push rod 32 and the permanent magnet move rearwardly and this operates the Hall effect device so that power is supplied to the motor 11. The torque is transmitted from the shaft 13 through the driving member 15 and the balls 21 to the driven member 16 and the screwdriver bit. During rotation below a predetermined torque, the balls 21 grip the boss 20, and the driving and driven members 15 and 16 respectively rotate in unison with the balls.

When the maximum torque is approached, the load retards the driven member 16 and the boss 20 turns slightly slower than the driving member 15. As a result, the balls 21 begin to roll along the respective camming surface of the boss and are cammed outwards against the force exerted by the sleeve 22. As this takes place, the sleeve is moved axially against the spring 24. When the set torque is reached, all the balls 21 are just before that edge of their camming surface remote from the respective detent recess and the groove 35 defined by the latch sleeve 27 and collar 26 is aligned with the radial passages accommodating the balls 34. Thus, the balls 34 are allowed to move radially away from the axis of the shaft 13 and such movement releases the latch bolt 33 which will move axially forward under the influence of return spring 40. Hence, the magnet moves forwardly and the Hall effect element operates to energize the motor. Due to the influence of any stored energy in the motor and gearbox, the driving member 15 will continue to rotate and the balls 21 will pass over the edge of the cam surfaces on the boss 20.

Thrust on the screwdriver bit is then relaxed thus allowing the driven member 16 to datum on shoulder 31 due to the influence of spring 30. The

push rod 36 is prevented from following the clutch assembly forward by shoulder 50. Spring 49 (which is weaker than spring 40) will hold the latch bolt 33 in contact with the push rod 36, so that as shaft 13 moves forward, the balls 34 are aligned with the groove in the latch bolt 33 and the latch sleeve 27 resets under the influence of spring 28.

On reverse rotation initiated by activating the touch switch pad 46, the situation is similar except that the balls 21 will move along the respective camming surface and into a detent recess of the boss as the predetermined torque is approached. These recesses lock onto the balls 21 and hence a greater force has to be applied to the balls before they run over the edges of the camming surfaces than was the case of rotation in the forward direction. In practice, the reverse rotation is used to remove a screw and sleeve 22 will not be moved enough to release push rod 32 and the balls will not run over the edges of the camming surfaces, because sufficient torque should be available to start the screw moving before this stage is reached.

As aforesaid, the position of the block 25 can be adjusted along the axis of the driving member 13 in order to vary the compression in the spring 24. By this means, the torque at which the sleeve 22 will move to release the push rod 32 can be varied.

In an alternative embodiment (not shown) each detent recess may be replaced with an ear which presents a more steeply inclined camming surface (i.e. a surface with a greater approach angle) to the balls than the remainder of the camming surface. Therefore, once again the balls 21 will need to have a greater force applied to them to overcome this steeper slope when the tool is operated in a reverse direction.

Moreover, other types of clutch with an unlatching device may be used, e.g. the clutch described in British Patent No. 1457496.

The provision of the Hall effect device comprising Hall effect element 43 and magnet 37, allows the push rod 32, push rod piston 36, magnet 37, and return spring 40 to slide freely within rotating parts whilst providing a compact arrangement. Moreover, the system has low inertia as only the push rod piston 36, magnet 37 and return spring 40 affect the response time of the system.

Instead of a push start tool as hereinbefore described, the torque sensitive clutch could be moved rearwardly towards the motor 11 by a lever mechanism (not shown) to energize the motor. In this case, the tool holder could be fixed against axial movement.

Instead of bringing the magnet 37 into line with the Hall effect element 43 to energize the motor, the reverse mode of switching could be employed where the magnet 37 moves out of line with the Hall effect element to energize the motor.

Furthermore, instead of using a latching mechanism associated with the push rod 32, the sleeve 22 could act on the forward end of the push rod such as through the intermediary of a pin

connected to the sleeve 22 and extending through slots in the shaft diametrically across the bores of the shaft 13. In this case, the motor may be energised by a touch sensitive switch mounted on the body of the tool. When a torque above said predetermined value is transmitted across the clutch, the push rod 32 moves the magnet 37 momentarily away from (or into line with) the Hall-effect element. The motor is switched off and an electric latching circuit holds the motor off until the pressure on the touch sensitive switch is released and, when required, re-applied. This arrangement is particularly applicable to a tool with an angle head i.e. with the axis of the tool holder at an angle, e.g. 90°, to the axis of the motor (and clutch).

The torque sensitive clutch could be replaced by any other appropriate torque sensitive device.

### Claims

1. A power tool comprising a casing (12) having a tool holder (17) and a motor (11) mounted therein, a torque sensitive device (15, 16, 21, 22) between the motor and the tool holder and switch means operable to cut off the motor when a torque above a predetermined value is transmitted across the device, characterised in that the switch means includes a Hall effect device, comprising a stationary Hall effect element (43) and a magnet (47) movable relative to the Hall effect element when the torque transmitted across the torque sensitive device exceeds said predetermined value.

2. The power tool of claim 1, characterised in that the torque sensitive device comprises torque sensitive device parts (15, 16, 22) movable axially relative to each other when the torque exceeds said predetermined value to move the magnet relative to the Hall effect element.

3. The power tool of claim 1 or claim 2, characterised in that the motor and the torque sensitive device are axially spaced apart, in that the Hall effect device is adjacent to the motor and in that an elongate actuating member (32) couples the torque sensitive device to the magnet of the Hall effect device.

4. The power tool of claim 3, characterised in that a gear-box (14) is interposed between the motor and the torque sensitive device and in that the elongate actuating member extends through the gear-box.

5. The power tool of any one of the preceding claims, characterised in that the Hall effect device is interposed between the motor and the torque sensitive device.

6. The power tool of any one of the preceding claims, characterised in that the motor is an electric motor.

7. The power tool of claim 7, characterised by a switch for reversing the direction of the motor.

8. The power tool of any one of the preceding claims, characterised in that the switch means is operable to energise the motor in response to axial movement of the torque sensitive device towards the motor.

### Patentansprüche

1. Motorgetriebenes Gerät mit einem Gehäuse (12), in dem ein Werkzeughalter (17) und ein Motor (11) angeordnet sind, mit einer drehmomentempfindlichen Vorrichtung (15, 16, 21, 22) zwischen dem Motor und dem Werkzeughalter, und mit Schaltmitteln zum Abschalten des Motors, wenn ein Drehmoment oberhalb eines vorbestimmten Wertes über die Vorrichtung übertragen wird, dadurch gekennzeichnet, daß die Schaltmittel eine Hall-Effekt-Einrichtung einschließen mit einem stationären Hall-Effekt-Element (43) und einem Magneten (37), der relativ zum Hall-Effekt-Element beweglich ist, wenn das über die drehmomentempfindliche Vorrichtung übertragene Drehmoment den vorbestimmten Wert übersteigt.

2. Motorgetriebenes Gerät nach Anspruch 1, dadurch gekennzeichnet, daß die drehmomentempfindliche Vorrichtung drehmomentempfindliche Vorrichtungsteile (15, 16, 22) umfaßt, die relativ zueinander axial beweglich sind, wenn das Drehmoment den vorgegebenen Wert übersteigt, um den Magneten relativ zum Hall-Effekt-Element zu bewegen.

3. Motorgetriebenes Gerät nach Anspruch 1 oder 2, dadurch gekennzeichnet, daß der Motor und die drehmomentempfindliche Vorrichtung axial räumlich voneinander getrennt sind, daß die Hall-Effekt-Einrichtung neben dem Motor liegt, und daß ein längliches Betätigungsglied (32) die drehmomentempfindliche Vorrichtung an den Magneten der Hall-Effekt-Einrichtung kuppelt.

4. Motorgetriebenes Gerät nach Anspruch 3, dadurch gekennzeichnet, daß zwischen dem Motor und die drehmomentempfindliche Vorrichtung ein Getriebe (14) eingeschaltet ist, und daß sich das längliche Betätigungsglied durch das Getriebe hindurch erstreckt.

5. Motorgetriebenes Gerät nach einem der voranstehenden Ansprüche, dadurch gekennzeichnet, daß die Hall-Effekt-Einrichtung zwischen dem Motor und der drehmomentempfindlichen Vorrichtung angeordnet ist.

6. Motorgetriebenes Gerät nach einem der voranstehenden Ansprüche, dadurch gekennzeichnet, daß der Motor ein Elektromotor ist.

7. Motorgetriebenes Gerät nach Anspruch 7, gekennzeichnet durch einen Schalter zur Umkehr der Laufrichtung des Motors.

8. Motorgetriebenes Gerät nach einem der voranstehenden Ansprüche, dadurch gekennzeichnet, daß die Schaltmittel so betätigbar sind, daß der Motor in Abhängigkeit von einer Axialverschiebung der drehmomentempfindlichen Vorrichtung zum Motor eingeschaltet wird.

### Revendications

1. Outil à moteur comprenant un boîtier (12) avec un porte-outil (17) et un moteur (11) monté à l'intérieur, un dispositif sensible au couple (15, 16, 21, 22) installé entre le moteur et le porte-outil et un moyen de commutation ayant pour objet d'arrêter le moteur quand un couple dépassant

une valeur prédéterminée est transmis dans le dispositif, caractérisé en ce que le moyen de commutation comprend un dispositif à effet Hall, comportant un élément fixe à effet Hall (43) et un aimant (37) mobile par rapport à l'élément à effet Hall quand le couple transmis aux bornes du dispositif sensible au couple dépasse ladite valeur prédéterminée.

2. Outil à moteur selon la revendication 1, caractérisé en ce que le dispositif sensible au couple comprend des parties du dispositif sensible au couple (15, 16, 22), mobiles dans la direction axiale l'une par rapport à l'autre quand le couple dépasse ladite valeur prédéterminée afin de déplacer l'aimant par rapport à l'élément à effet Hall.

3. Outil à moteur selon l'une quelconque des revendications 1 ou 2, caractérisé en ce que le moteur et le dispositif sensible au couple sont espacés dans la direction axiale, en ce que le dispositif à effet Hall est adjacent au moteur et en ce qu'un élément de commande allongé (32) accouple le dispositif sensible au couple à l'aimant du dispositif à effet Hall.

4. Outil à moteur selon la revendication 3, caractérisé en ce qu'une boîte d'engrenage (14) est intercalée entre le moteur et le dispositif sensible au couple et en ce que l'élément allongé de commande traverse la boîte d'engrenage.

5. Outil à moteur selon l'une quelconque des revendications précédentes, caractérisé en ce que le dispositif à effet Hall est intercalé entre le moteur et le dispositif sensible au couple.

6. Outil à moteur selon l'une quelconque des revendications précédentes, caractérisé en ce que le moteur est un moteur électrique.

7. Outil à moteur selon la revendication 6, caractérisé par un commutateur permettant d'inverser le sens de rotation du moteur.

8. Outil motorisé selon l'une quelconque des revendications précédentes, caractérisé en ce que le moyen de commutation est capable d'agir pour donner de l'énergie au moteur en réponse à un mouvement axial du dispositif sensible au couple en direction du moteur.

5

10

15

20

25

30

35

40

45

50

55

60

65

5

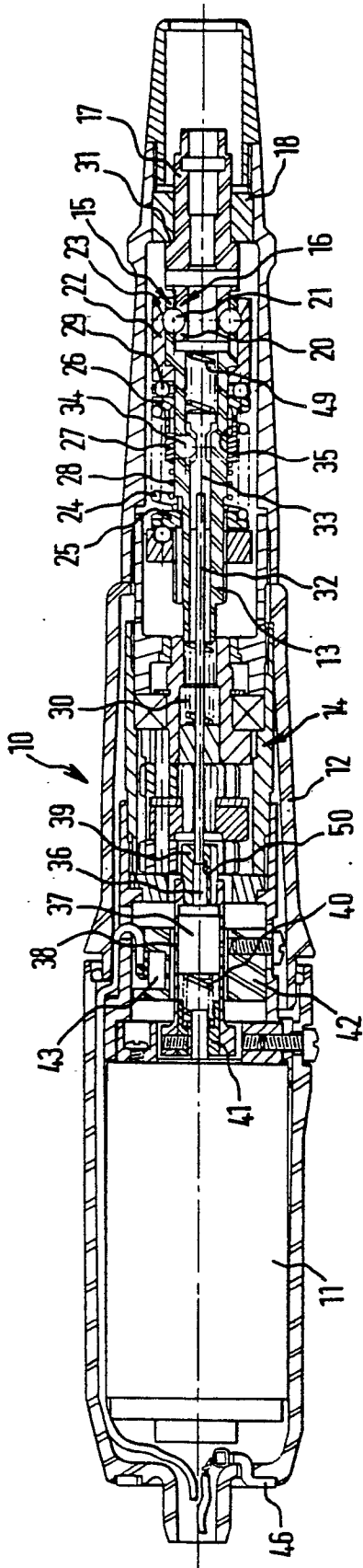

FIG. 1.

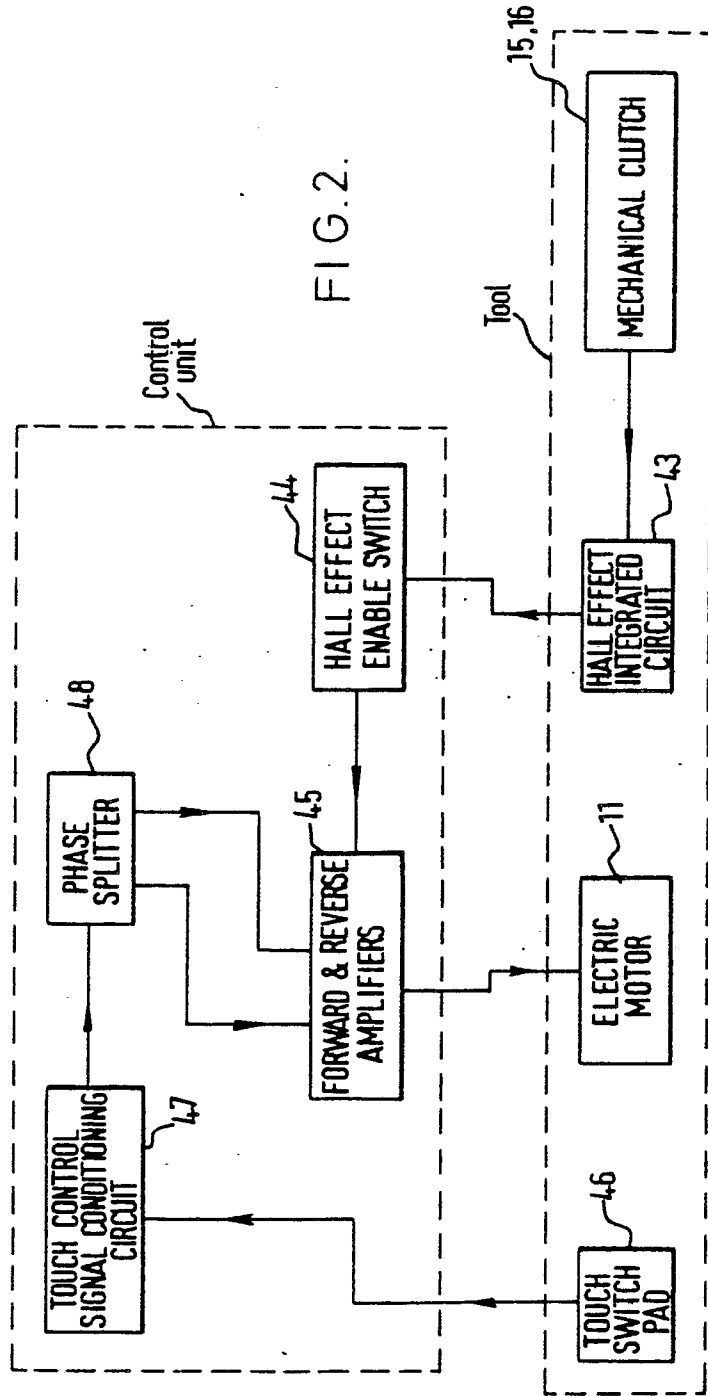

FIG. 2.