

⑫ **EUROPEAN PATENT SPECIFICATION**

④⑤ Date of publication of patent specification: **16.01.85**

⑤① Int. Cl.<sup>4</sup>: **E 05 B 67/26, E 05 B 19/00**

②① Application number: **81103287.9**

②② Date of filing: **30.04.81**

---

⑤④ **Cylinder lock resistant to picking.**

---

④③ Date of publication of application:  
**10.11.82 Bulletin 82/45**

⑦③ Proprietor: **Huang, Tsao-Keng**  
**73-2, Yung Le Lane Yu Feng Tsuen**  
**Shui Li Hsiang Nan Tou Hsien (TW)**

④⑤ Publication of the grant of the patent:  
**16.01.85 Bulletin 85/03**

⑦② Inventor: **Huang, Tsao-Keng**  
**73-2, Yung Le Lane Yu Feng Tsuen**  
**Shui Li Hsiang Nan Tou Hsien (TW)**

④④ Designated Contracting States:  
**AT BE CH DE FR IT LI LU NL SE**

⑦④ Representative: **Flügel, Otto, Dipl.-Ing. et al**  
**Dipl.-Ing. Otto Flügel Dipl.-Ing. Manfred Säger**  
**Patentanwälte Cosimastrasse 81 Postfach 810**  
**540**  
**D-8000 München 81 (DE)**

⑤⑥ References cited:  
**DE-C- 179 910**  
**DE-C- 593 541**  
**US-A-1 526 728**  
**US-A-1 849 070**  
**US-A-2 460 551**  
**US-A-3 320 783**  
**US-A-4 138 868**

**EP 0 064 087 B1**

---

Note: Within nine months from the publication of the mention of the grant of the European patent, any person may give notice to the European Patent Office of opposition to the European patent granted. Notice of opposition shall be filed in a written reasoned statement. It shall not be deemed to have been filed until the opposition fee has been paid. (Art. 99(1) European patent convention).

## Description

The present invention concerns a cylinder lock and a key for unlocking this lock, comprising a body with a hook, and locking means to prevent the hook from being pulled out from locked position to unlocked position; a rotatable cylinder with its upper end structured so as to co-operate with the locking means to allow the hook to be pulled out when the cylinder is turned to a certain position; a bush with one of its ends forming a tortuous entrance into which the key can be screwed, said bush being fixedly secured in the body.

Basically conventional cylinder keys comprise substantially a planar key with an indented edge, a cylinder, and a body internally provided with a plurality of pin tumblers resiliently retained in a tunnel orienting to the keyway. When a key with a contoured profile on one edge is inserted into the keyway from the keyhole, the pins will be contacted by these undulation, and once the correct key is inserted thereinto, then the pin tumblers will all be arranged in such a position as to allow the cylinder to be turned. Straight in structure, the keyway of such conventional lock are liable to be picked by probing a wire therein. Moreover, the resilient means, generally springs, which urge the pin tumblers against the notches of a key at a specific level to discriminate if the key is the correct one, are hair-spring thin. After some use accumulation of rust or dirt may lead to failure of such fine parts, thus reducing the life of the lock.

Still further, traditional locks are complicated in their construction which means that these are difficult to assemble and to manufacture and which also means that the cost of production is high.

There is known a lock of this kind according to the generic motion of the main claim (US—A—1 849 070) which, however, is not only difficult to manufacture but, in addition, does not offer reliable protection against picking.

Finally, it is known (US—A—1 526 728) to provide a spiral entrance with locks into which the key can be screwed.

It is the main object of this invention to provide a cylinder lock which obviates the above defects in that the lock is more secure against unauthorised unlocking without the use of the correct key and also that the use of spring loaded wards is obviated. Thus the life of the lock is increased.

In a cylinder lock and a key of the type indicated in the prior art portion of claim 1 this object in conformity with the present invention is reached in that:

the tortuous entrance in the bush has a spiral shape having pitch and lead angle corresponding to the spiral provided on the key; the bush is provided with a plurality of ward means receivable in a plurality of female

locking means, to prevent the rotation of the cylinder;

the key is provided with a plurality of male locking means receivable in corresponding said female locking means, when the key is screwed into the spiral entrance of the lock and pushed into the lock, said male locking means acting on the ward means engaged into the female locking means so as to relieve the effect of the ward means and allow the rotation of the cylinder.

A preferred feature of this invention is that the resilient means can be economically a thick metal reeds instead of the springs fabricated by extremely fine wire, thus enhancing the durability and reducing the cost of the manufacture thereof.

Other and important objects of this invention will be apparent from the following description, claims and accompanying drawing.

Figure 1 is an exploded perspective view of a cylinder lock constructed in accordance with the invention;

Figure 2 is a longitudinal cross-sectional view of the assembled lock of Figure 1 with the key in position;

Referring now to the drawings, the cylinder lock according to the invention includes a body, a cylinder, a bush and a key, generally designated by reference numerals (10), (20), (30), and (40) respectively.

In the preferred embodiment of Figure 1, the body has a bore (11) which receives cylinder (20) and bush (30), the former being rotatable therein, whereas the latter being immovably secured in place, for example by passing a pin (15) through hole (151).

Hook (12) has a recess (121), the dimension and the position of which allow one part of ball (13) retained within a hole (14) to enter when the hook is in locked position in blind hole (16) so that it cannot be pull up. Like structure may be formed at the other leg of hook (12). (See Figure 2).

At one end of cylinder (20) there are provided with two opposite recesses (26), each of which is formed by a cutout defined by two intersecting faces (261) (262). When the cylinder is turned to a position such that face (261) directly opposite to ball (13), i.e. normal to the long axis of hole (14), the clearance between the inner wall of body (10) and the upper end of cylinder is broadest and enough to allow the ball to totally leave recess (121) to free hook (12) so that the latter can be unlocked (see Figure 2). Similarly, when cylinder (20) is turned in reverse direction, the non-recessed portion (27) urges ball (13) back into recess (121) to lock hook (12).

To allow only selective entry of specific keys, the outer end of bush (30) is provided with a spiral entrance (31) which is structured so that only an object with spiral structure of which the pitch and lead angle substantially coincides with

that of the entrance is allowed to be screwed thereinto. Further, to discriminate whether or not the key thus enters is the correct one, the lower end (21) of cylinder (20), which is nested in the upper end of bush (30), forms a plurality of slots (22) spaced apart from each other around the periphery of end (21) and extending along the length of cylinder (20). Complementary to these slots, the end of key (40), in a preferred embodiment, forms an enlarged end (42) provided with a plurality of projectors (41) arranged around the periphery thereof, the dimension and position of which projections substantially coincide with the slots (22), and at the site the upper end of bush corresponding to each slot (22) there is a hole (32), through which a ward piece (33) is resiliently urged inwardly to reach one of said slots (22). The projections are preferably ridged extending along the length of said key. Preferably ward piece (33) is inseparably fixed to one end of a spring reed (34), the other end of the latter being secured to the outer wall of bush (30) by, for example, welding or by a screw (not shown).

To allow key (40) to be screwed into the lock through the spiral entrance (31), there is provided a spiral groove (43) extending across the projections (41), which spiral groove (43) is bitten into by the helical edge (311) of spiral entrance (31), thereby allowing the key to be screwed into the bush to reach cylinder. When the whole length of spiral groove passes through the spiral entrance, the key can be directly pushed axially so that the projections fit into their corresponding slots.

With the projections, the enlarged end (42) of the key looks like a gear. However, unlike the gears, the width of each projection and the distance between any two adjacent projections may differ greatly at random, depending on the design of the slots (22). As all of the pitch and the lead angle of the spiral entrance, and the position and number of the slots may vary arbitrarily, the probability that a lock happened to be unlocked by the key of another such lock is extremely low, thus ensuring high security and reliability of this invention.

An alternative modification of the key (40), designated by (40'), is also feasible. It has a spiral shank (43'), with a length of its front forming a plurality of projections at the outer side. To adapt to such modification, the slots (22) of cylinder (20) and the ward pieces (33) and holes (32) of bush (30) must be arranged in a spiral trajectory instead of a circumference. This is easy to understand, and therefore not illustrated in the drawing. However, the spiral shank must be structured so that it, before reaching the slots, can be pushed inwardly a short distance in axial direction to fit its projection into mating slots.

### Claims

1. A cylinder lock and a key for unlocking this lock, comprising:

- a body (10) with a hook (12), and locking means (13) to prevent the hook (12) from being pulled out from locked position to unlocked position;
- a rotatable cylinder (20) with its upper end structured so as to co-operate with the locking means (13) to allow the hook (12) to be pulled out when the cylinder (20) is turned to a certain position;
- a bush (30) with one of its ends forming a tortuous entrance into which the key (40, 40') can be screwed said bush (30) being fixedly secured in the body (10), characterized in that:
  - the tortuous entrance (31) in the bush (30) has a spiral shape having pitch and lead angle corresponding to the spiral provided on the key;
  - the bush (30) is provided with a plurality of ward means receivable in a plurality of female locking means, to prevent the rotation of the cylinder;
  - the key (40, 40') is provided with a plurality of male locking means receivable in corresponding said female locking means, when the key (40, 40') is screwed into the spiral entrance (31) of the lock and pushed into the lock, said male locking means acting on the ward means engaged into the female locking means so as to relieve the effect of the ward means and allow the rotation of the cylinder (20).

2. The lock and key according to Claim 1, wherein said locking means to prevent said hook from being pulled are a ball (13) reciprocally retained in a hole (14) of said body (10) communicating with a recess (121) on one leg of said hook, in a manner such that when said lock is in locked condition, part of said ball (13) is urged by the upper and of said cylinder (20) to fit into said recess, and when said lock is in unlocked condition, said ball can completely leave said recess (121).

3. The lock and key according to Claim 1 or 2, wherein the upper end of said cylinder (20) has at least a recessed portion which allow said ball (13) to enter when said cylinder (20) is turned to unlocked position.

4. The lock and key according to Claim 1, wherein said ward means are a plurality of ward pieces (33) resiliently urged to engage with said female locking means of said cylinder (20).

5. The lock and key according to claim 1, wherein said female locking means are a plurality of slots (22) arranged around the periphery of said cylinder (20), extending axially, and opening at the lower end of said cylinder.

6. The lock and key according to claim 1, 4 or 5, wherein said male locking means are a plurality of projections (41) corresponding to said slots (22) and are designed such that when one of such a projection (41) engages with its corresponding slot (22), the corresponding ward

piece (33) is repelled outward and no longer prevent the rotation of said cylinder (20).

7. The lock and key according to Claim 1, 4, 5 or 6, wherein said bush (30) is provided with a hole at each side of said ward piece (33) to allow the latter to pass through.

8. The lock and key according to Claim 1 or 4, wherein each of said ward pieces (33) is fixed to a spring reed fixed on the outer wall of said bush and resiliently urging said ward piece toward said slot.

9. The lock and key according to Claim 6, characterised in that said projections (41) are a plurality of ridges extending along the length of said key (40) and spaced around an enlarged portion near the tip end of said key (40).

10. The lock and key according to Claim 9, wherein the enlarged portion of the key (40) is provided with a spiral groove (43) around said portion and cutting across said ridges; the width, depth, pitch, and lead angle of said groove (43) being such that it enable said key to be screwed through said spiral entrance (31) into said lock.

11. The lock and key according to Claim 1, characterised in that the anterior portion of the key (40') is a spiral shank with at least a length thereof provided with a plurality of projections corresponding to the slots of said cylinder, the dimension, pitch and lead angle of which shank being such that it can be screwed into said lock through said spiral entrance (31) and then pushed axially a distance so that its projections may fit into corresponding slots (22) of said cylinder (20).

12. The lock and key according to Claim 1, wherein the spirality of said entrance of said key can be either clockwise or counterclockwise viewing from the gripping end of the key.

## Revendications

1. Serrure à barillet et clé de déverrouillage de cette serrure comprenant:

- un corps (10) avec un crochet (12) et des dispositifs de verrouillage (13) empêchant de tirer le crochet (12) vers l'extérieur en le faisant passer de la position verrouillée à la position déverrouillée;
- un barillet tournant (20) dont l'extrémité supérieure est structurée de façon à coopérer avec les dispositifs de verrouillage (13) pour permettre de tirer le crochet (12) vers l'extérieur lorsque le barillet (20) est tourné dans une certaine position;
- un douille (30) formant à l'une de ses extrémités une entrée contournée dans laquelle la clé (40, 40') peut être vissée, cette douille (30) étant solidement fixée au corps (10), caractérisé par le fait que
- l'entrée contournée (31) de la douille (30) a une forme en spirale dont le pas et l'angle d'avance correspondent à la spirale existant sur la clé;

— la douille (30) présente une pluralité de gardes qui peuvent pénétrer dans une pluralité de dispositifs de verrouillage femelles pour empêcher la rotation du barillet;

- 5 — la clé (40, 40') présente une pluralité de dispositifs de verrouillage mâles pouvant pénétrer dans les dispositifs de verrouillage femelles correspondants lorsque la clé (40, 40') est vissée dans l'entrée en spirale (31) de la serrure et poussée vers l'intérieur de la serrure, ces dispositifs de verrouillage mâles agissant sur les gardes engagées dans les dispositifs de verrouillage femelles de façon à supprimer l'effet des gardes et à permettre la rotation du barillet (20).

2. Serrure et clé selon la revendication 1, dans lesquelles les dispositifs de verrouillage empêchant de tirer le crochet vers l'extérieur sont constitués d'une bille (13) pouvant être ou non maintenue dans un orifice (14) du corps (10) en communication avec un évidement (121) ménagé dans un bras du crochet, de sorte que si la serrure est en position verrouillée, une partie de cette bille (13) est poussée par l'extrémité supérieure du barillet (20) et pénètre dans l'évidement et si la serrure est en position déverrouillée, cette bille est complètement délogée de l'évidement (121).

3. Serrure et clé selon l'une des revendications 1 ou 2, dans lesquelles l'extrémité supérieure du barillet (20) présente au moins une portion délogée pour permettre à cette bille (13) de pénétrer quand le barillet (20) est tourné en position déverrouillée.

4. Serrure et clé selon la revendication 1, dans lesquelles le dispositif de garde est constitué d'une pluralité de gardes (33) poussées de façon élastique à s'engager dans des dispositifs femelles de verrouillage dudit barillet (20).

5. Serrure et clé selon la revendication 1, dans lesquelles les moyens de verrouillage femelles sont constitués d'une pluralité de fentes (22) disposées sur la pourtour du barillet (20), orientées dans le sens de l'axe et s'ouvrant à l'extrémité inférieure dudit barillet.

6. Serrure et clé selon l'une des revendications 1, 4 ou 5 dans lesquelles les dispositifs de verrouillage mâles sont constitués d'une pluralité de parties en saillie (41) correspondant aux fentes (22) et ont une structure telle que si l'une des parties en saillie (41) s'engage dans la fente correspondante (22), la garde correspondante (33) est repoussée vers l'extérieur et n'empêche plus la rotation du barillet (20).

7. Serrure et clé selon l'une des revendications 1, 4, 5 ou 6 dans lesquelles la douille 30 présente un orifice à chaque position d'une garde (33) pour permettre à cette dernière de passer par cet orifice.

8. Serrure et clé selon l'une des revendications 1 ou 4, dans lesquelles chacune des gardes (33) est fixée à une lame de ressort elle-

même maintenue sur la paroi extérieure de la douille et poussant de façon élastique la garde vers la fente.

9. Serrure et clé selon la revendication 6, caractérisées par le fait que les parties en saillie (41) sont constituées d'une pluralité de nervures orientées sur la longueur de la clé (40) et espacées autour d'une partie élargie voisine de l'extrémité de la clé (40).

10. Serrure et clé selon la revendication 9, dans lesquelles la partie élargie de la clé (40) présente une nervure en spirale (43) coupant les nervures; la largeur la profondeur, le pas et l'angle d'avance de cette nervure (43) étant tels qu'ils permettent de visser la clé dans l'entrée en spirale (31) de la serrure.

11. Serrure et clé selon la revendication 1, caractérisées par le fait que la partie antérieure de la clé (40') est une tige en spirale dont au moins une portion de la longueur présente une pluralité de parties en saillies correspondant aux fentes du barillet, la dimension, le pas et l'angle d'avance de cette tige étant tels que la clé puisse être vissée dans la serrure par l'entrée en spirale (31) et ensuite poussée dans la direction axiale sur une certaine distance de façon que ses parties en saillie puissent pénétrer dans les fentes correspondantes (22) dudit barillet (20).

12. Serrure et clé selon la revendication 1, dans lesquelles les caractéristiques de la spirale de l'entrée de la clé peuvent correspondre à une rotation dans le sens des aiguilles d'une montre ou dans le sens inverse vue depuis l'extrémité par laquelle on tient la clé.

### Patentansprüche

1. Zylinderschloß und Schlüssel zur Entriegelung des Schlosses, mit einem einen Haken (12) aufweisenden Körper (10) und Verriegelungseinrichtungen (13) zur Verhinderung, daß der Haken (12) aus der verriegelten Lage heraus in die entriegelte Lage gezogen wird, mit einem drehbaren Zylinder (20), dessen oberes Ende mit den Verriegelungseinrichtungen (13) zusammenwirkend ausgebildet ist und ermöglicht, daß der Haken (12) herausgezogen werden kann, wenn der Zylinder (20) in eine bestimmte Lage gedreht wird, mit einer Hülse (30), deren eines Ende einen gewundenen Eingang bildet, in welchen der Schlüssel (40, 40') hineingedreht bzw. hineingeschraubt werden kann, wobei die Hülse (30) in dem Körper (10) verdrehfest angeordnet ist, dadurch gekennzeichnet, daß der gewundene Eingang (31) in der Hülse (30) eine Spiralförmigkeit aufweist, der Steigungswinkel bzw. Ganghöhe jener der dem Schlüssel ausgebildeten Spiralförmigkeit entspricht, daß die Hülse (30) mit einer Vielzahl von Zuhaltungseinrichtungen versehen ist, die zur Verhinderung der Drehung des Zylinders in einer Vielzahl von aufnehmenden Verriegelungseinrichtungen aufgenommen werden, daß der Schlüssel (40, 40') mit einer Vielzahl von eintretenden Verriegelungseinrichtungen versehen

ist, die in den aufnehmenden Verriegelungseinrichtungen aufgenommen werden, wenn der Schlüssel (40, 40') in den spiralförmigen Eingang (31) des Schlosses hineingedreht und in das Schloß geschoben wird, wobei die eintretenden Verriegelungseinrichtungen auf die in die aufnehmenden Verriegelungseinrichtungen eingreifenden Zuhaltungseinrichtungen derart einwirken, daß die Wirkung der Zuhaltungseinrichtungen aufgehoben und die Drehung des Zylinders (20) ermöglicht wird.

2. Schloß und Schlüssel nach Anspruch 1, dadurch gekennzeichnet, daß die das Herausziehen des Hakens verhindernden Verriegelungseinrichtungen in Form einer Kugel (13) vorgesehen sind, die hin- und herbewegbar in einem Loch (14) des Körpers (10) befindlich ist und mit einer Vertiefung (121) an einem Schenkel des Hakens derart kommuniziert, daß im verriegelten Zustand des Schlosses ein Teil der Kugel (13) durch das obere Ende des Zylinders (20) paßgerecht in die Vertiefung gedrückt wird und daß im entriegelten Zustand des Schlosses die Kugel vollständig aus der Vertiefung (121) heraustreten kann.

3. Schloß und Schlüssel nach Anspruch 1 oder 2, dadurch gekennzeichnet, daß das obere Ende des Zylinders (20) mindestens einen Vertiefungsbereich aufweist, in welchen die Kugel (13) eintreten kann, wenn der Zylinder (20) in die Entriegelungslage gedreht wird.

4. Schloß und Schlüssel nach Anspruch 1, dadurch gekennzeichnet, daß die Zuhaltungseinrichtungen in Form einer Vielzahl von Zuhaltungsdaumen (33) vorgesehen sind, die federelastisch in Eingriff mit den aufnehmenden Verriegelungseinrichtungen des Zylinders (20) gebracht werden.

5. Schloß und Schlüssel nach Anspruch 1, dadurch gekennzeichnet, daß die aufnehmenden Verriegelungseinrichtungen in Form einer Vielzahl von Schlitten (22) vorgesehen sind, die um die Peripherie des Zylinders (20) angeordnet sind, sich in axialer Richtung erstrecken und sich am unteren Ende des Zylinders (20) öffnen.

6. Schloß und Schlüssel nach einem der Ansprüche 1, 4 oder 5, dadurch gekennzeichnet, daß die eintretenden Verriegelungseinrichtungen in Form einer Vielzahl von Vorsprüngen (41) vorgesehen sind, die den Schlitten (22) entsprechen und so ausgebildet sind, daß bei Ineingreifen eines dieser Vorsprünge (41) mit dem entsprechenden Schlitz (22) der entsprechende Zuhaltungsdaumen (33) nach außen gestoßen wird und die Drehung des Zylinders (20) nicht mehr behindert.

7. Schloß und Schlüssel nach einem der Ansprüche 1, 4, 5 oder 6, dadurch gekennzeichnet, daß die Hülse (30) auf jeder Seite des Zuhaltungsdaumens (33) eine Öffnung aufweist, die den Durchtritt des Zuhaltungsdaumens erlaubt.

8. Schloß und Schlüssel nach Anspruch 1 oder 4, dadurch gekennzeichnet, daß jeder der

Zuhaltungsdaumen (33) an einer Blattfeder befestigt ist, die ihrerseits an der Außenwand der Hülse festgelegt ist und den Zuhaltungsdaumen in Richtung Schlitz drückt.

9. Schloß und Schlüssel nach Anspruch 6, dadurch gekennzeichnet, daß die Vorsprünge (41) in Form einer Veilzahl von Rippen vorgesehen sind, die sich entlang der Länge des Schlüssels (40) erstrecken und rund um den vergrößerten Bereich in der Nähe des oberen Endes des Schlüssels (40) voneinander beabstandet angeordnet sind.

10. Schloß und Schlüssel nach Anspruch 9, dadurch gekennzeichnet, daß der vergrößerte Bereich des Schlüssels (40) eine Spiralnute bzw. spiralförmige Vertiefung (43) aufweist, die rund um diesen Bereich verläuft und die Rippen durchschneidet, wobei Breite, Tiefe, Steigungswinkel und Ganghöhe der Vertiefung (43) so bemessen sind, daß der Schlüssel über den spiralförmigen Eingang (31) in das Schloß gedreht bzw. geschraubt werden kann.

11. Schloß und Schlüssel nach Anspruch 1, dadurch gekennzeichnet, daß der vordere Bereich des Schlüssels (40') als spiralförmiger Schaft ausgebildet ist, der mindestens über einen Abschnitt seiner Länge mit einer Vielzahl von den Schlitz des Zylinders entsprechenden Vorsprüngen versehen ist, wobei Größe, Steigungswinkel und Ganghöhe des Schafts so bemessen sind, daß letzterer über den spiralförmigen Eingang (31) in das Schloß hineingedreht werden und dann in axialer Richtung ein Stück geschoben werden kann, so daß die Vorsprünge ihre paßgerechte Lage in den entsprechenden Schlitz (22) des Zylinders (20) annehmen.

12. Schloß und Schlüssel nach Anspruch 1, dadurch gekennzeichnet, daß die Spiralförmigkeit des Eingangs des Schlüssels von dem Griffende des Schlüssels aus gesehen entweder mit oder gegen den Uhrzeigersinn verlaufend ausgebildet sein kann.

25

30

35

40

45

50

55

60

65

6

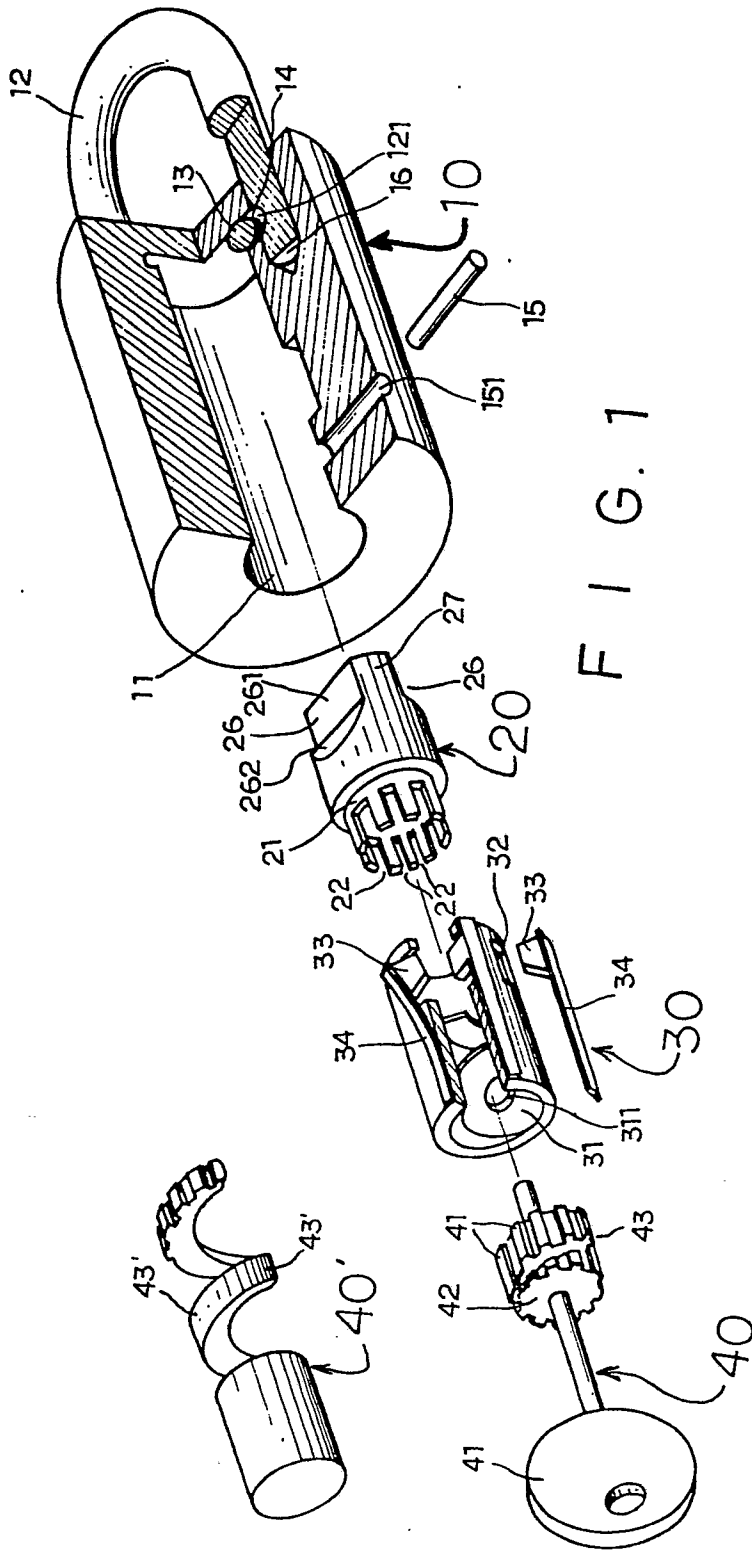

FIG. 1

0064087

