

**EUROPEAN PATENT APPLICATION**

Application number: 82830103.6

Int. Cl.<sup>3</sup>: **H 01 R 13/707**

Date of filing: 22.04.82

Priority: 19.05.81 IT 2179481

Applicant: **SARNO S.p.A., Via Crispi 96, Napoli (IT)**

Date of publication of application: 15.12.82  
Bulletin 82/50

Inventor: **Ranzanigo, Pierluigi, Via Cave 68,  
I-25060 Mompiano (Brescia) (IT)**

Designated Contracting States: **AT BE CH DE FR GB LI  
LU NL SE**

Representative: **La Ciura, Salvatore, Via Francesco  
Sforza 5, I-20122 Milano (IT)**

**Perfections to heavy-duty outlets with mechanical interlock switch.**

The invention refers to a heavy-duty electrical outlet (7) with mechanical interlock switch (5) in which said mechanical interlock is equipped with a further restraint (29) interlocked with the main cover (4) of the casing, preventing closing of the switch (5) and release of the mechanical interlock when said cover (4) is removed. This restraint (24) can be moved to a first position, where the cover (4) is closed, in which it permits standard switch maneuvers and insertion and removal of the plug, and to a second position, where the cover (4) is removed, and in which the restraint (29) blocks the safety bar (20) of the interlock device and the lever (18) moved by the plug (37) that connects to the outlet, preventing both manual movement of these components and closure of the switch for as long as the cover remains removed.

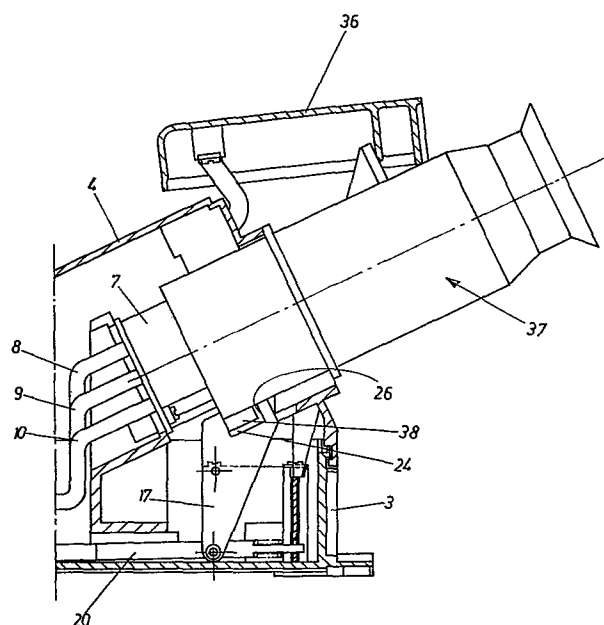

**EP 0 067 129 A1**

- 1 -

Perfections to heavy-duty outlets with mechanical  
interlock switch

The present invention has its object the perfection of heavy-duty electrical outlets with mechanical interlock switch.

5 As is known outlets with mechanical interlock switches constitute a special type of three-pole or four-pole heavy-duty outlet, associated with a switch that controls the supply of current to the outlet, designed in such a way that the switch is guaranteed to be open both when  
10 the plug is inserted into the outlet and when the plug must be removed from the outlet. These outlets are also designed so that, when the switch is closed, it is not possible to perform plug engagement or disengagement maneuvers -plug maneuvers with current present are preven  
15 ted.

In accordance with known technology, heavy-duty outlets of the type specified, consist of a container box made of an isolating material and sealed closed by a cover,  
20 which shall from now on be called the main cover.

Removal of the main cover gives access to the components contained inside the box, permitting installation and maintenance operations.

- 5 Also in accordance with known technology, plugging in or pulling out the plug that connects to the outlet do not require removal of said main cover, because the outlet is situated facing a special opening in the box or in the main cover. This opening, which is automatically closed  
10 when the plug is absent, shall be called the outlet cover, and is kept closed by spring return devices.

The switch is a rotary or pack type, meaning that it opens or closes by rotation of a shaft perpendicular to the  
15 bottom of the box. This shaft is driven by a knob that sticks out from the main cover. The switch shaft is then connected to a disk, or cam, which makes up part of an interlock device, so that the disk makes rotations equal to those of the shaft when the switch itself is opened or  
20 closed. Depending on whether the switch is open or closed this disk presents, in specific positions, a slot or a blank face.

The mechanical interlock unit basically consists of a level  
25 swinging on a fulcrum fixed to the box and installed near the outlet. This lever is joined to a bar at its front end and this bar presses against the cam profile at its other end, due to the force of a spring.

30 The other end of the lever is equipped with engagement

mechanisms that act with complementary components carried by the casing of the plug that is being inserted into the outlet, so that when the plug is inserted the lever swings so that it moves the bar against the pressure of the return  
5 spring, moving it away from the cam, whereas when the plug is removed the lever moves in the opposite direction, pushing the bar back.

The length of the bar is calculated so that when it presses  
10 against the cam profile, meaning when the switch is closed, it creates a restraint that stops the lever from swinging, so that it is impossible to pull out or plug in a plug.

These operations are only possible if the cam, in front  
15 of the rear end of the bar, presents the opening that permits the bar to move back- meaning when the switch is open.

In this type of layout, when the plug is disengaged, the  
20 end of the bar is inserted in the hole in the cam, making it impossible to close the switch.

In these known outlets, safety maneuvers- inserting or unplugging the plug with the switch open- are only valid  
25 when the main box cover is closed. In fact they present the serious defect of permitting conscious or unconscious maneuvers when the cover is removed, such as can take place during installation or maintenance.

30 It is always possible that the installer, trusting in his

own experience, may insert the plug and close the switch, turning the switch shaft with a tool, for example, and then may mistakenly leave the box open with voltage being carried by all internal components.

5

Or this operation may be done by another, less expert person who needs an immediate hook-up to a user.

The serious danger of such a situation is not just that  
10 someone might touch the appliances under voltage, which can easily have mortal consequences, but also that solid or liquid substances may drop in the box (rain, snow, chemicals, metal objects, etc.) and cause serious short-  
-circuits, causing great harm both to the electrical mains  
15 and, for example, to foodstuffs being stored or processed.

The goal of the present invention is to furnish a heavy-  
-duty electrical outlet with interlock switch that prevents  
switch maneuvers in all circumstances, even with the main  
20 cover removed. This gives these switches an extra degree of safety, and prevents the hazards outlined above.

The invention's heavy-duty outlet is characterized by the fact that it's box carries a restraint that cooperates  
25 with the box's main cover. This restraint can be moved to a first position, where the main cover is closed, where it does not interfere with the safety bar and lever assembly moved by the plug, permitting this assembly to operate normally with the main cover closed, and to a second  
30 position, caused by removal of the cover, where it blocks

the safety bar and lever assembly, preventing the safety bar from leaving the cam hole, and thus preventing the switch from being closed.

5 Other advantages and characteristics will appear with greater clarity in the detailed description of a preferential, but not exclusive, embodiment of a safety restraint for heavy-duty outlets with mechanical interlock switches, given in the following, with reference to the  
10 enclosed drawings, as a purely indicative, and in no way limiting, embodiment of the invention, where:

Figure 1 illustrates a longitudinal cross-section of a heavy-duty outlet with mechanical interlock  
15 switch, equipped with the safety restraint object of the present invention;  
Figure 2 gives a top view of the mechanical switch block device;  
Figure 3 gives a cross-section view of the safety  
20 restraint in the position it takes on when the main cover is removed.  
Figure 4 gives corss-section IV°-IV° of figure 3,  
Figure 5 gives a view like that in figure 3, with the cover mounted on its base.

25  
With reference to these illustrations, and above all to the first one, the number 1 indicates the heavy-duty outlet with mechanical interlock switch as a whole. This type of outlet basically consists of case 2, box 3 and  
30 cover 4 which closes onto and seals box 3. Box 3 houses

multi-pole switch 5, supported by a rail, schematized by 6, and multi-pole outlet 7 closed inside its own casing.

Reference numbers 8, 9 and 10 indicate electrical cables  
5 that connect outlet 7 to switch 5.

Other electrical connections, not illustrates, are required to connect switch 5 with the electrical mains.

10 Note that switch 5 has been representes in the manner usually done by known technology, meaning a pack type with revolving axial control shaft, but rather in the shape of several single-pole switches placed side-by-side, with control levers interlocked with each other and operated  
15 simultaneously. The use of these switches does not constitute part of the present invention, but rather is object of a separate patent application, deposited on the same date as the present.

20 The object and the goals of the present invention, however, do not change when the practical embodiment uses a revolving shaft according to known technology.

In the case of figure 1, therefore, multiple control lever  
25 11, designed to open or close the switch, sticks out from switch 5. This lever is opportunely coupled with control component 12 and through this, with a knob, indicated by number 13 and housed in seat 14 made in the main cover.

30 Disk 15, part of mechanical interlock assembly 16, is placed

below switch 5. Lever 11 and disk 15 are connected together in such a way that disk 15 takes on precise angular positions in the open and closed positions of the lever.

5 The mechanical interlock, in addition to disk 15, consists of lever 17 pivoted at 18 on base 3 and jointed at 19, at a pre-determined point, with safety bar 20. With reference to figure 1 and 2, safety bar 20 has its rear end 20a sliding in guide 21. This end 20a, is pushed towards the disk by  
10 spring 23, which acts on the bar, so that it automatically engages with slot 22 presented by the disk itself whenever it is turned in the "switch open" position.

The top section of lever 17 carries slot 24, bordered by  
15 two operative opposed shoulders, indicated by 25 and 26.

The number 27, in accordance with the present invention, indicates a component assembly which, when the cover is removed from box 3, interferes with safety bar 20, stopping  
20 it from moving, and consequently preventing release of disk 15 and closure of switch 5. This component 27 is moved when cover 4 is inserted on base 3 so that it leaves a passage that permits safety bar 20 to slide forward. This, consequently, releases disk 15 and control tang 11 of switch 5.

25  
To do this the bottom of cover 4 carries appendix 28, where, according to a preferential embodiment, said component 27 consists of a wall 29 which slides between lateral guides 30 and 31 machined in outcropping 32 of base 3 (figure 4).  
30 Wall 29 is equipped with thru opening 33 which, when the

cover is removed from the base, is moved with respect to front end 20b of safety bar 20. In this manner safety bar 20 remains axially blocked between cavity 22 on disk 15 and wall 29, so that, with the cover removed, it is impos-  
5 sible to perform manual release, using lever 17, nor can the switch be closed, nor can a plug be plugged into the outlet, since engagement will be prevented by lever 17 itself, which cannot move.

10 The aforementioned position of hole 33 is achieved thanks to the presence of counter-spring 34, which pushes wall 29 against fixed locator 35 placed above the wall itself. As a consequence, when cover 4 is removed, there is no danger that current will be applied to internal components. This  
15 avoids the predictable hazards pointed out previously. When cover 4 is lowered onto base 3 for connection to it, appendix 28 presses against the top side of wall 29, lowering it and bringing hole 23 in alignment with end tooth 20b of safety bar 20. Consequently only when cover  
20 4 is applied can normal plug maneuvers, as per known technology, be carried out. These shall be described in the following to give greater clarity to this exposition. With special reference to figures 1 and 5, note that cover  
25 4 is equipped with tilting outlet cover 36, which functions only to keep access to the outlet closed when the plug is not inserted. This outlet cover must be lifted when plug 37 is inserted. The casing of plug 37 carries jut 38 which, when the plug is inserted, presses against shoulder 25 of slot 24 made in lever 17. This action causes the lever to  
30 swing, which moves safety bar (20) to the right (in the

illustrations). Given that in this situation hole 34 of wall 29 is coaxial with tooth 20b of bar 20, this bar is free to move and release itself from the restraint of slot 22 on disk 15.

5

This action causes release of disk 15 and thus of lever 11 of switch 5, which can therefore be used to close the circuit by maneuvering knob 13. This engagement maneuver is only possible if lever 17 is initially in the position in figure 1, with slot 24 moved to the right and bar 20 engaged with slot 22, thus with the switch open.

10

Plug 37 can be pulled out from the outlet only when the switch is open. Its removal causes movement in the opposite direction of all the components of mechanical interlock device 16.

15

As we have said previously, these movements cannot be performed when cover 4 is removed from base 3, because safety bar 20 will remain blocked in its movements on one side by the presence of disk 15 and on the other by wall 29, which is situated with hole 34 out of alignment with respect to end 20b of safety bar 20.

20

Naturally tooth 20b, instead of being at the front end of bar 20, can extend sideways out from the bar, in a middle position, and likewise wall 29 can be placed in such a position.

25

Restraint, in any case, instead of being provided by

30

wall 29, can be provided by a different shape component, as long as it carries an opening that is aligned or not-aligned with tooth 20b when, respectively, the cover is mounted or is removed.

5

Obviously many structural variants and modifications can be brought to the safety outlets described under the present invention without in any way departing from its area of patent protection.

## Claims.

1. Heavy-duty electrical outlet with mechanical interlock switch of the type including a box, closed by a cover,  
5 containing a multi-pole current outlet facing an opening in the box, or in the cover, closed by a special outlet cover when the plug is not plugged in, by a multi-pole switch feeding this outlet, opened and closed by a knob carried by the cover, and by a mechanical interlock device  
10 consisting of a disk with a hole which, when the switch is open, becomes aligned with the end of a safety bar, which has its other end jointed with a lever destined to be moved by a plug when the plug is inserted or pulled out with the switch open, characterized by the fact that  
15 there is a restraint carried by the box, and cooperating with the main cover of the box, such that it can be moved to a first position, caused by closing the main cover, where it does not interfere with the safety bar assembly, moved by the plug, permitting normal plug maneuvers, and  
20 normal movements of this safety bar and lever assembly, when the main cover is closed, and to a second position, caused by removal of the main cover, where it blocks said assembly, preventing the safety bar from existing from the hole in the cam moved by the switch, and thus preventing  
25 the switch itself from being closed, and also stopping the safety bar and lever from being moved manually.
2. Heavy-duty electrical outlet as per claim 1, characterized by the fact that in a preferred embodiment said  
30 restraint takes the shape of a wall placed on a plane

perpendicular to the safety bar, and equipped with an opening that is designed to cooperate with a tooth presented by that bar, and that this wall is pushed by elastic mechanisms and slides in guides made in the outlet box, in  
5 such a way that, when the cover is closed, it presents its opening facing the bar tooth, permitting the bar to move out from the hole in the can driven by the switch, and permitting normal outlet operating maneuvers, whereas when the cover is removed, the wall presents a black surface  
10 to the tooth, stopping the bar from moving out from the aforesaid hole, and thus stopping the switch from closing.

3. Heavy-duty electrical outlets according to the previous claims and according to what was described and illustrated.

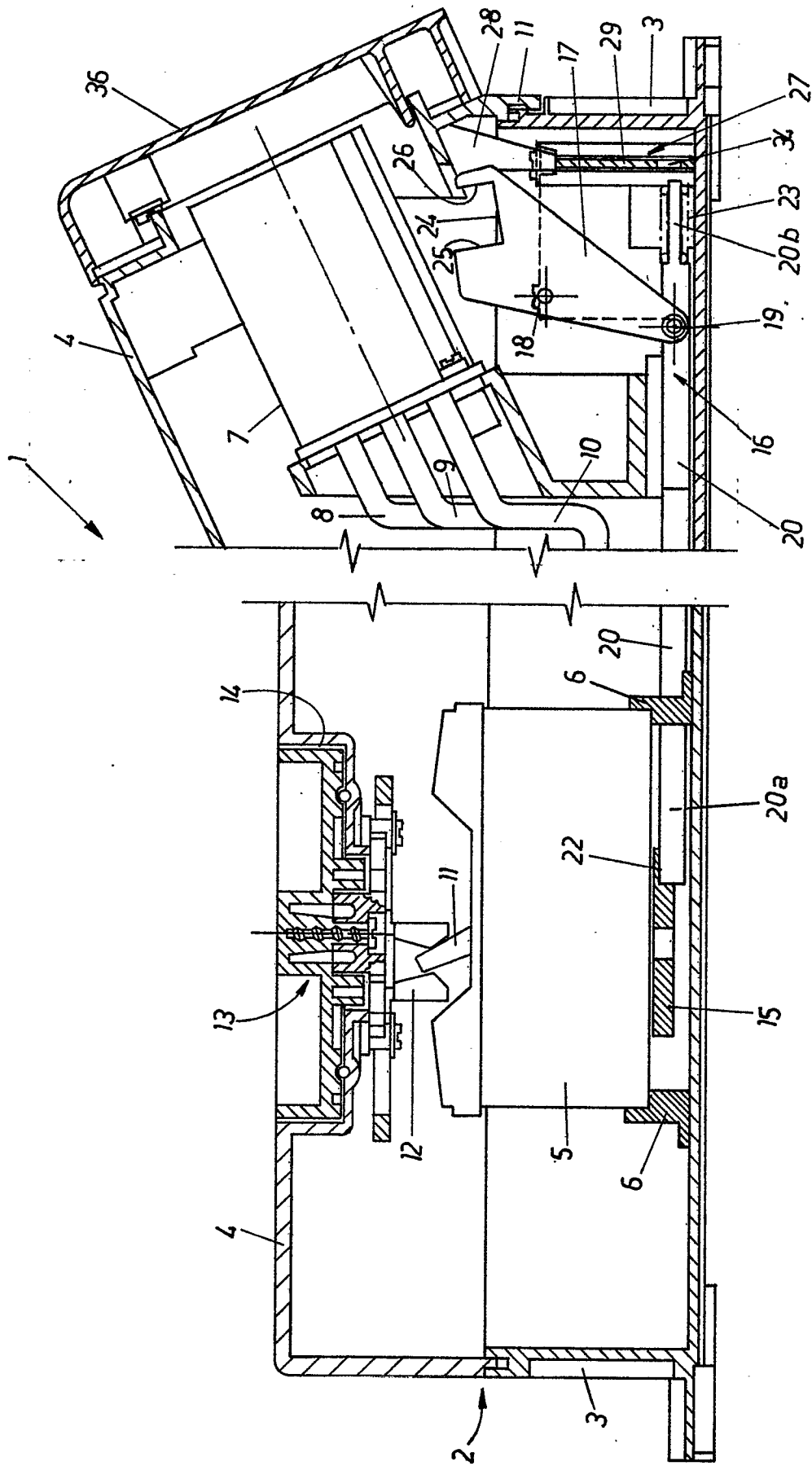

FIG. 1

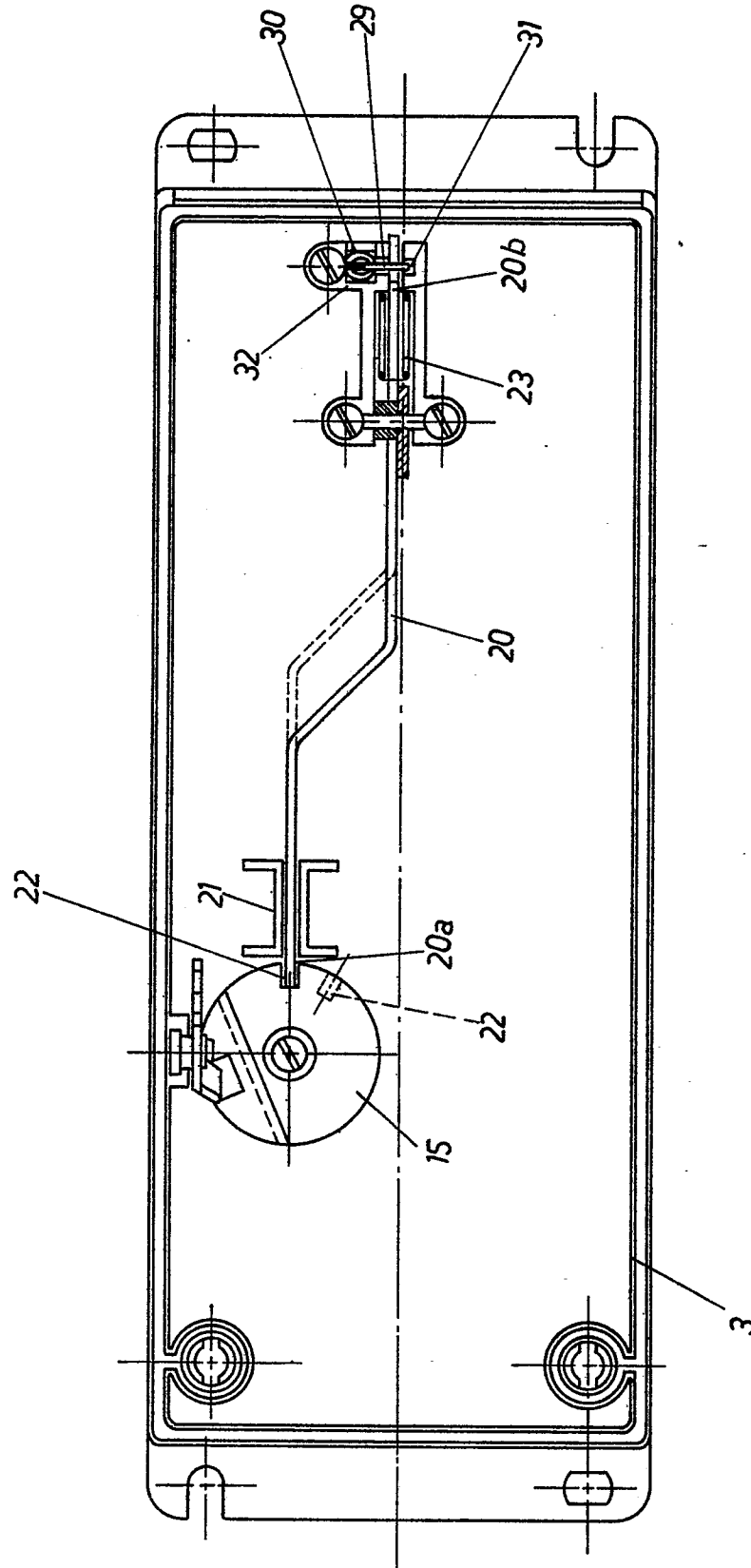

FIG. 2

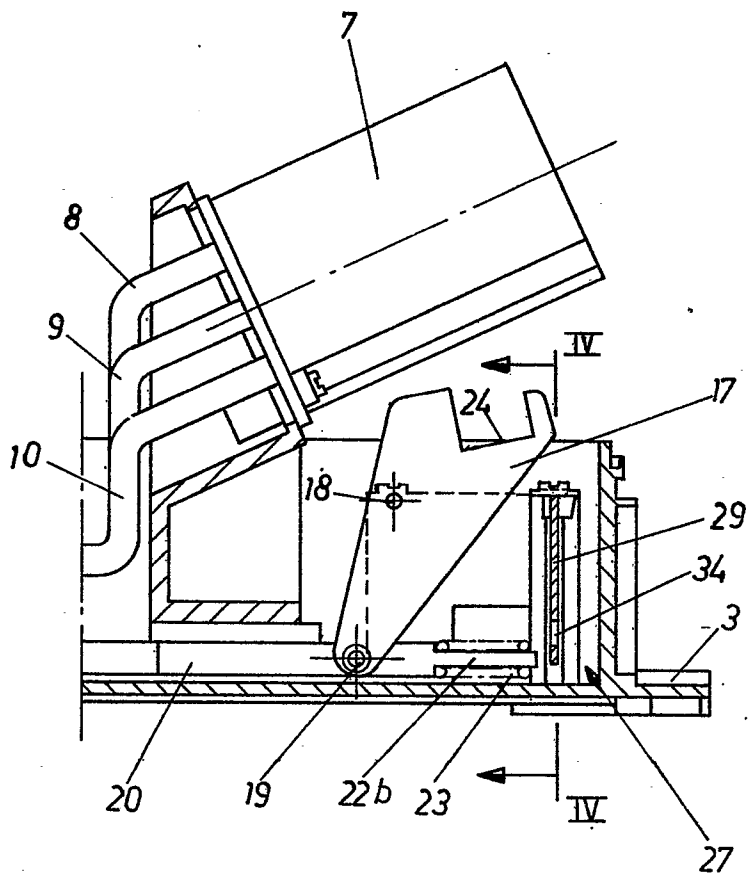

FIG. 3

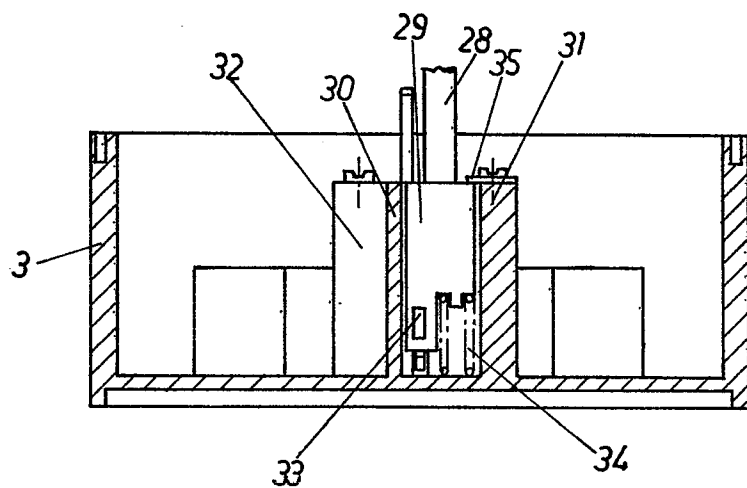

FIG. 4

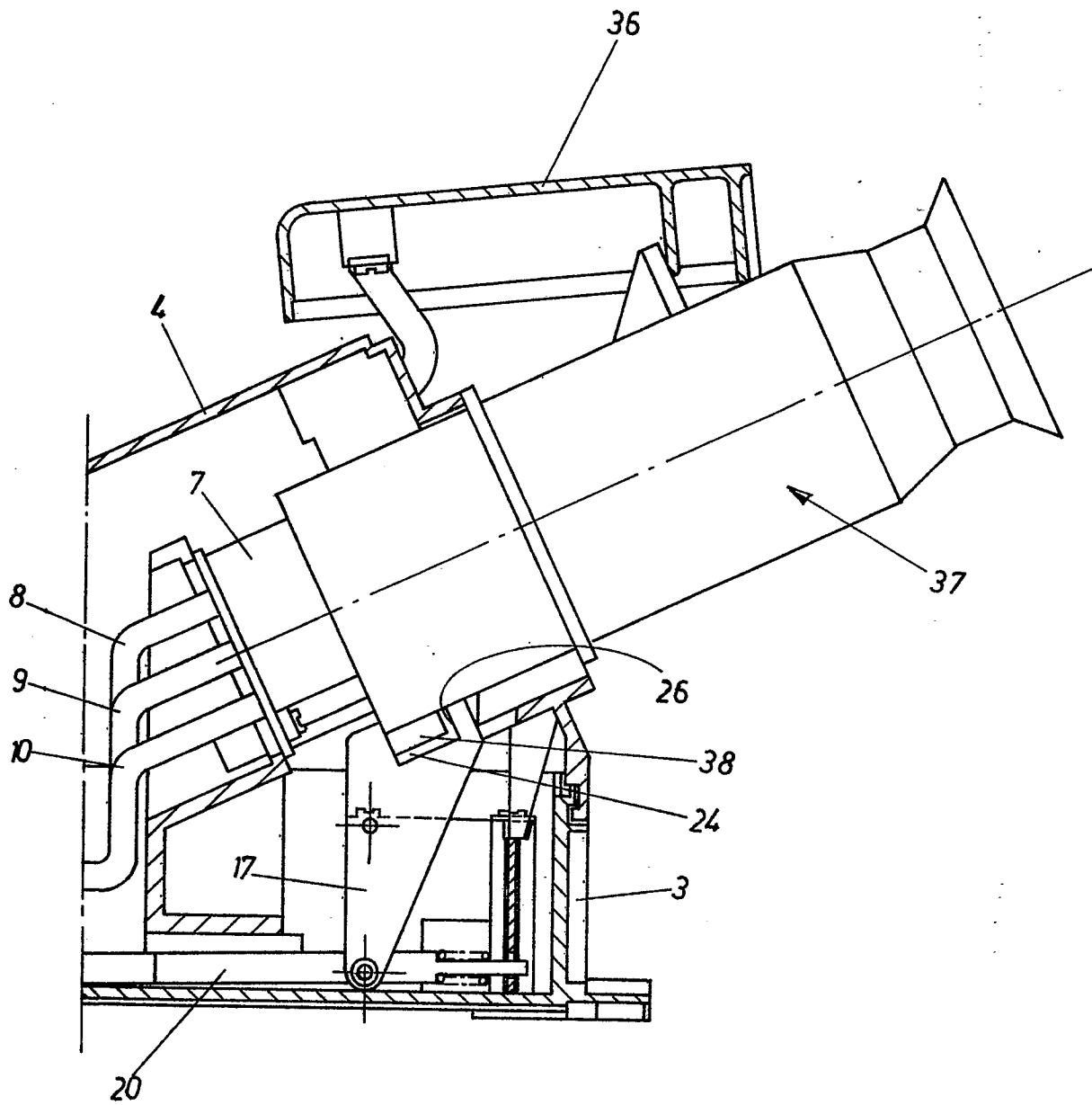

FIG. 5



DOCUMENTS CONSIDERED TO BE RELEVANT			
Category	Citation of document with indication, where appropriate, of relevant passages	Relevant to claim	CLASSIFICATION OF THE APPLICATION (Int. Cl. <sup>3</sup> )
A	FR-A- 969 849 (SOCIETE GARNIER) * Page 1, column 2, paragraphs 4,5; page 2, column 1 *	1,2	H 01 H 13/707
A	DE-A-1 908 187 (ELEKTRA TAILFINGEN) * Page 3; figures 3,4 *	1,2	
A	US-A-2 888 529 (I.T.E.) * Column 3, line 60 - column 4, line 69 *	1	
A	US-A-3 110 778 (I.T.E.) * Column 2, line 45 - column 4, line 5 *	1,2	
			TECHNICAL FIELDS SEARCHED (Int. Cl. <sup>3</sup> )
			H 01 R 13/00 H 01 H 9/00 H 01 H 33/00
The present search report has been drawn up for all claims			
Place of search THE HAGUE		Date of completion of the search 31-08-1982	Examiner JANSSENS DE VROOM P.
CATEGORY OF CITED DOCUMENTS		T : theory or principle underlying the invention E : earlier patent document, but published on, or after the filing date D : document cited in the application L : document cited for other reasons & : member of the same patent family, corresponding document	
X : particularly relevant if taken alone Y : particularly relevant if combined with another document of the same category A : technological background O : non-written disclosure P : intermediate document			