

EUROPEAN PATENT APPLICATION
 published in accordance with Art. 158(3) EPC

Application number: 82900133.8

Int. Cl.³: F 04 D 17/04

Date of filing: 21.12.81

Data of the international application taken as a basis:

International application number:
PCT/JP81/00400

International publication number:
WO82/02228 (08.07.82 82/17)

Priority: 23.12.80 JP 183035/80
 25.12.80 JP 186422/80
 15.04.81 JP 57363/81

Date of publication of application:
29.12.82 Bulletin 82/52

Designated Contracting States:
DE FR GB

Applicant: Matsushita Electric Industrial Co., Ltd.
 1006, Oaza Kadoma
 Kadoma-shi Osaka-fu, 571(JP)

Inventor: NAWA, Motoyuki
 529-20, Gakuen Asahimotomachi 2-chome
 Nara-shi Nara-ken 631(JP)

Inventor: SUGAWARA, Norio
 1-49-102, Tsurumai Higashimachi
 Nara-shi Nara-ken 631(JP)

Inventor: TAKAHASHI, Yutaka
 535-37, Nakayama-cho Nishi, 3-chome
 Nara-shi Nara-ken 631(JP)

Representative: Crawford, Andrew Birkby et al,
 A.A. THORNTON & CO. Northumberland House 303-306
 High Holborn
 London WC1V 7LE(GB)

FLOW DIRECTION CONTROL DEVICE.

A flow direction control device (11) for controlling the direction of the air flow from a cross flow fan (12). Roughly circular arc-shaped control blades (27) are disposed with the cross flow fan, the low pressure vortex of the fan is restricted within the control blades, and the direction of the air flow can be controlled over a wide angle around the entire periphery of the fan with a compact construction in accordance with the rotation of the control blades (27). Also, with respect to the external region of the fan divided into two regions by partition members (46), (47), conversion between the normal and reverse flow directions can be achieved based upon this principle by rotating the control blades (27).

Fig. 1

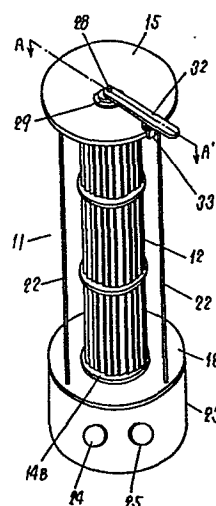

SPECIFICATION**TITLE MODIFIED**

see front page

TITLE: A fluid deflecting apparatus

5 TECHNICAL FIELD

This invention relates to control of the direction of flow of a fluid discharged from a cross-flow fan.

BACKGROUND ART

10 There is known a technology of controlling the direction of flow of a fluid discharged from a cross-flow fan, such as the provision of a guide plate at the discharge outlet of the fan as taught by British Patent No. 983,901. However, the range of control of flow as obtainable by
15 such an arrangement is limited to the region where the guide plate is positioned. That is to say, deflection of a fluid over the entire circumferential direction of the fan cannot be accomplished. Moreover, because the guide plate as a deflecting means is positioned externally
20 of the fan, the entire apparatus cannot be constructed in a compact layout. Japanese Utility Model Laid-Open Patent Kokai Sho 55-161087 discloses an apparatus wherein a guide plate is disposed within a cross-flow fan. However, such guide plate is intended to improve the efficiency of
25 the fan and, moreover, because it is fixed in position, the guide plate does not have a function of controlling the direction of flow.

DISCLOSURE OF THE INVENTION

This invention relates to a fluid deflecting apparatus wherein a control vane rotatably disposed inside of a cross-flow fan is configured and positioned in such a manner that the low-pressure vortex of the fan will be confined on the inner side of the vane, whereby the direction of flow from the fan can be controlled over the whole circumferential direction of the fan in a compact construction.

Preferred embodiments of this invention will hereinafter be described in detail, reference being had to the accompanying drawings.

BRIEF DESCRIPTION OF THE DRAWINGS

Fig. 1 is a perspective view showing a fluid deflecting apparatus according to this invention.

Fig. 2 is a sectional view along the line A-A' of Fig. 1;

Figs. 3 and 4 are sectional views taken along the line B-B' of Fig. 2, showing the states of flow at the cross-flow fan according to different positions of the control vane;

Fig. 5 is a perspective view of the control vane according to another embodiment of this invention;

Fig. 6 is a sectional view showing the flow within the cross-flow fan which is obtainable with the control vane illustrated in Fig. 5;

Fig. 7 is a partially exploded perspective view showing the fluid deflecting apparatus as another embodiment of this invention;

5 Fig. 8 is a sectional view taken along the line C-C' of Fig. 7;

Figs. 9 and 10 are sectional views taken along the line D-D' of Fig. 7, showing different states of flow;

Fig. 11 is a sectional view of flow in a still another embodiment of this invention;

10 Fig. 12 is a sectional view showing another yet embodiment of this invention;

Fig. 13 is a perspective view showing still another fluid deflecting apparatus of this invention;

15 Fig. 14 is a sectional view along the line E-E' of Fig. 13; and

Figs. 15, 16 and 17 are sectional views along the line F-F' of Fig. 13, showing different states of flow.

BEST MODE FOR CARRYING OUT THE INVENTION

20 One embodiment of this invention will be described below, reference being taken to Figs. 1 to 4. The reference numeral 11 indicates a fluid deflecting apparatus, the numeral 12 a cross-flow fan, and the numeral 13 a motor. The cross-flow fan 12 has end plates 14A
25 and 14B which are rotatably supported by bearings 17 and 18 at side plates 15 and 16, respectively. The end plate 14B is rigidly secured to a shaft 20 of the motor 13,

whereby the cross-flow fan 12 revolves together with the shaft 20 of motor 13. The motor 13 is rigidly mounted on the side plate 16 by means of a motor support 21. The side plate 15 is secured in position with three posts 22 projecting from the side plate 16. The reference numeral 23 indicates a casing which secures the side plate 16 in position. The casing 23 is provided with a dial 24 for turning the motor 13 on and off and a dial 25 for controlling the number of revolutions thereof. The casing 23 is further provided with an opening 26 for cooling the motor 13 with natural ventilation. Disposed within the cross-flow fan 12 is a control vane 27. One rotary shaft 28 affixed to this control vane 27 extends through a bore of the hollow end plate A and is rotatably supported by a retaining plate 29 fixedly secured to the side plate 15. Another rotary shaft 30 affixed to the other end of the control vane 27 is rotatably supported by a recess 31 formed at the end of shaft 20 of the motor 13. Thus, the two rotary shafts 28 and 30 are capable of revolving about m which is the axis of revolution of shaft 20 of motor 13 and the center of rotation of the cross-flow fan 12. This revolution is effected with a lever 32 affixed to the rotary shaft 28. The lever 32 is so desired that it can be set in a desired position with an engaging means 33 which is secured thereto and engageable with the side plate 15.

The cross-flow fan which is conventionally employed for an air conditioner has a stabilizer and a rear guider, and a low-pressure voltex is generated in the vicinity of the stabilizer. Referring to the cross-flow fan 12
5 illustrated in Fig. 3, the addition of said stabilizer and rear guider thereto generates a low-pressure voltex with a radius of r . The control vane 27 disposed within the cross-flow fan has a substantially arcuate cross-section and its radius R is defined as $R > r$. The control
10 vane 27 is disposed in such a manner that ends of its arc will be located near an inner circumference 36 of the cross-flow fan 12 and has an angle θ such that the low-pressure voltex V will be confined on the inner side of the arc of the control vane 27. Where the radius of the
15 inner circumference 36 of cross-flow fan is defined as r_a , the value of r is approximately $1/2 r_a \sim r_a$.

The operation of the fluid deflecting apparatus according to this invention will be described below.

Referring to Figs. 1 and 2, as the dial 24 is turned
20 on, the shaft 20 of the motor 13 starts revolving, whereupon the end plate 14B affixed to this shaft 20 is rotated to drive the cross-flow fan 12. When the control vane 27 is in the position shown in Fig. 3, if the direction of rotation of the cross-flow fan 12
25 is clockwise as indicated by the arrow-mark C, the low-pressure voltex V will also have a clockwise direction of flow and the flow on the outside of the control vane 27

is directed substantially in the direction indicated by the arrow-mark X. As aforesaid, the radius R of the control vane 27 is larger than the radius r of the low-pressure voltex in the case of existence of the stabilizer and rear guider for the cross-flow fan and the ends 34, 35 of the arc of control vane 27 are located near the inner circumference 36 of cross-flow fan 12 with the angle θ of the control vane 27 being such that the low-pressure voltex V will be confined within the inner side thereof. Therefore, despite the fact that there is no restricting member other than the control vane 27, such as a guider, the low-pressure voltex V is stabilized on the inner side of the control vane 27 and the external flow X on the outer side of the control vane 27 is also stabilized accordingly.

Let it be assumed that the lever 32 is rotated to bring the control vane 27 into the position illustrated in Fig. 4. Then, because of the absence of a restricting member other than the control vane 27, the low-pressure voltex V spins as it remains confined on the inner side of the control vane 27 and is stabilized in the position indicated in Fig. 4. The flow external of the control vane 27 is as indicated by the arrow-mark Y.

Thus, because the only restricting member for the low-pressure voltex V is the control vane 27, the position of the low-pressure voltex V can be shifted to an optional position on the circumference of the cross-flow fan 12 by nothing other than the rotation of the control vane 27. Thus, the flow on the outer side of the control vane 27 can be directed in an optional direction on the circumference

so that the fluid can be deflected over the entire circumferential range of 360 degrees. Since, in this arrangement, there is no obstruction such as a casing outside of the fan, fluid deflection control can be accomplished in a compact arrangement and there also is the advantage that changing the direction of the vane does not cause changes in the volume of wind, noise or characteristics.

A second embodiment of this invention will now be described with reference to Figs. 5 and 6. The reference numeral 37 indicates a control vane, supporting members 38A and 38B thereof being displaced from rotary shafts 39A and 39B by the length l . This control vane 37 is disposed in place of the control vane 27 of Fig. 2 and the rotary shafts 39A and 39B are in place of the rotary shafts 28 and 30, respectively. As in the first embodiment, the control vane 37 can be rotated and set in a desired position about the axis of rotation of the cross-flow fan by means of a lever 32.

In this embodiment, too, the control vane 37 has a substantially arcuate cross-section and its radius R' is larger than the radius r of the low-pressure vortex of the conventional cross-flow fan equipped with a guider. Moreover, the control vane 37 is so designed that ends of its arc 40A and 40B are located near the inner circumference 36 of the cross-flow fan 12 and has an angle θ' such that the low-pressure vortex V is confined on the inner side of

the arc of control vane 37. The operation of this fluid
deflecting apparatus is similar to that of the first
embodiment. Thus, by rotating the control vane 37, the
low-pressure vortex V can be shifted to any optional
5 position on the circumference of the cross-flow fan 12,
whereby the flow Z on the outer side of the control vane
37 can be directed in an optional direction. In this
embodiment, since the support members 38A and 38B of the
control vane 37 are displaced from the center of rotation
10 of the cross-flow fan 12, the width of flow Z on the
outer side of the control vane 37 can be increased.

In the above two embodiments, the control vanes 27
and 37 are rotated manually with use of the lever 32.
However, by connecting the rotary shaft 28 of the control
15 vane 27 or the shaft 39A of the vane 37 directly to the
shaft of a small-sized motor, the deflection of a fluid
over the range of 360 degrees can be automatically
accomplished. When the motor is of reversible rotation,
the desired air swing action can be accomplished without
20 resort to a complicated linkage mechanism.

A third embodiment of this invention will now be
described.

Referring to Figs. 7 through 10, the reference
numeral 41 indicates a fluid deflecting apparatus, 42
25 a cross-flow fan, and 43 a motor. Indicated by 44A and
44B are side plates. The reference symbols 45A and 45B
indicate retaining plates which retain the side plates

44A and 44B, respectively, in position.

A first partitioning member 46 and a second partitioning member 47 divide the zone external of the cross-flow fan 42 into two regions A and B.

5 Blades 48 of the cross-flow fan 42 are secured rigidly with end plates 49 and 50 and intermediate plates 51. The end plate 49 has a cylindrical portion 52 which is rotatably supported by a bearing 53 at the side plate 44A. The end plate 50 is connected to a shaft 54 of a
10 motor 43. The motor 43 is rigidly secured to the side plate 44B with a member 55.

 Disposed within the cross-flow fan is a control vane 56, one shaft 57 of which is supported in a recess 58 formed in the shaft 54 of the motor 43 while the other
15 shaft 59 extends through bores of the end plate 49 and cylindrical portion thereof and is rotatably supported by a supporting plate 60 rigidly secured to the side plate 44A. A rotary shaft 59 is provided with a spring retaining plate 61 to the left of the cylindrical
20 portion 52 and biased to the right by a spring 62 interposed between itself and a supporting plate 60. Affixed to the left end of the rotary shaft 59 is a dial 63 so that the control vane 56 can be rotated about the rotary shafts 57 and 59 and set in an optional position by turning the
25 dial 63.

The control vane 56 has a substantially arcuate cross-section and is so designed that ends of its arc 64 and 65

are located near the inner circumference of the cross-flow fan 42 and the angle θ thereof is such that the low-pressure vortice of the cross-flow fan 42 is confined on the inner side of the arc of the control vane 56.

5 The first and second partitioning members 46 and 47 are plano-configured.

 In the above construction it is assumed that as illustrated in Fig. 9, the recess 67 of the control vane 56 is opposite to the partitioning member 46. Then,
10 as the cross-flow fan 42 turns in the direction of the arrow-mark C on revolution of the shaft 54 of the motor 43, a low-pressure vortice V is generated between the recess 67 of the control vane 56 and the partitioning member 46. Thereupon, a flow as indicated by the arrow-mark E is generated between the control vane 56 and the
15 partitioning member 47. Thus, there is generated a flow of fluid from region A to region B.

 Then, let it be assumed that the control vane 56 is rotated about the rotary shaft 59 to bring the recess
20 67 thereof into the position opposite to the partitioning member 47.

 Now, a low-pressure vortice V of the cross-flow fan 42 is generated between the recess 67 of control vane 56 and the partitioning member 47. Thereupon, a flow as
25 indicated by the arrow-mark E' is generated between the control vane 56 and the partitioning member 46. Thus, there is established a flow of fluid from region B to

region A.

Thus, a positive or a reverse flow can be selectively obtained with ease by a mere rotation of the control vane 56.

5 A fourth embodiment of this invention will be described below, reference being had to Fig. 11.

The construction illustrated in Fig. 11 is almost similar to that of Fig. 9 but there is a difference in the configuration of partitioning members 68 and 69.

10 The partitioning members 68 and 69 have side portions 70 and 71 which define fluid passages 73 and 74 with the external circumference 72 of the cross-flow fan 42. The partitioning members 68 and 69 are so configured as are inclined inwardly with respect to the direction of
15 rotation of the fan 42 so that the fluid passages 73 and 74 are constricted toward the direction of rotation of the fan 42.

Let it be assumed that in the above arrangement, the recess 67 of the control vane 56 is opposite to or faces
20 the partitioning member 68. As the shaft 54 of the motor 43 revolves and the cross-flow fan 42 is thereby driven in the direction indicated by the arrow-mark C, a low-pressure vortex is generated between the recess 67 of control vane 56 and the partitioning member 68. Since
25 the side portion 70 of the partitioning member 68 is inclined inwardly with respect to the outer circumference of the cross-flow fan 42, the formation of the low-pressure

voltex V is further promoted. Accordingly, the flow F between the control vane 56 and the partitioning member 69 is further stabilized and takes a more stable form of flow from region A to region B.

5 When the control vane 56 is rotated until its recess 67 comes into a position opposite to the partitioning member 69, there again is generated a solid low-pressure voltex between the recess 67 and the partitioning member 69 by virtue of the side portion 71
10 of the partitioning member 69, whereby a stabilized flow is established from region B to region A.

A fifth embodiment of this invention will be described below with reference to Fig. 12.

The construction illustrated in Fig. 12 is almost
15 similar to that of Fig. 9 but there is a difference in the configuration of partitioning members 75 and 76. The partitioning members 75 and 76 have substantially arcuate recesses 77 and 78 corresponding to the shape of the fan 42 and are located in such positions as
20 encircling the low-pressure voltex V generated by revolution of the fan 42 together with the recess 67 of the control vane 56.

Let it be assumed that, in the above arrangement, the recess 67 of the control vane 56 is in a position
25 opposite to the partitioning member 75. As the rotation of the shaft 54 of the motor 43 causes the cross-flow fan to turn in the direction indicated by the

arrow-mark C, a low-pressure vortex V is generated between the recess 67 of control vane 67 and the recess 77 of the partitioning member 75. Since the low-pressure vortex V is stabilized and confined
5 between the two recesses 67 and 77, the flow F on the outer side of the control vane 56 is also stabilized and takes the form of a stable flow from region A to region B.

A stable, confined low-pressure vortex V is obtained
10 also when the control vane has been rotated until its recess 67 faces the recess 78 of the partitioning member 76. Accordingly, the flow from region B to region A is also stabilized.

Thus, a positive or a reverse flow of fluid can be
15 easily obtained by a mere rotation of the control vane 56 and the flow that can thus be obtained is stabilized.

A sixth embodiment of this invention will now be described.

Referring to Figs. 13 through 17, the reference
20 numeral 81 indicates a fluid deflecting apparatus, 82 a cross-flow fan, and 83 a motor. Indicated by the numerals 84 and 85 are side plates which are supported by a first partitioning member 86 and a second partitioning member 87.

25 Blade 88 of a cross-flow fan 82 are secured in position with end plates 89 and 90 and an intermediate plate 91. The end plate 89 has a cylindrical portion 92

which is rotatably supported by a bearing 93 at the side plate 84. The end plate 90 is connected to a shaft 94 of a motor 83. The motor 83 is rigidly secured to a side plate 85 with a member 95.

5 Disposed within the cross-flow fan 82 is a control vane 96, one rotary shaft 97 of which is supported by a recess 98 formed in the shaft 94 of the motor 83 while the other rotary shaft 99 thereof extends through the bore of the side plate 89 and its cylindrical
10 portion 92 and is rotatably supported by a support plate 100 rigidly secured to the side plate 84. The rotary shaft 99 is provided with a spring retaining member 101 to the left of said cylindrical portion 92 and is biased to the right by a spring 102 interposed between itself
15 and the supporting plate 100. The rotary shaft is fitted at its left end with a dial 103, revolution of which enables the control vane to be rotated about the rotary shafts 97 and 99 and set in an optional position.

 The control vane 96 has a substantially arcuate
20 cross-section and is so designed that ends 104 and 105 of its arc are located near the inner circumference 106 of the cross-flow fan 82 and has an included angle θ such that the low-pressure vortex of the cross-flow fan 82 is confined on the inner side of the control vane 96.

25 The partitioning members 86 and 87 are substantially plano-configured.

 The operation of the apparatus will now be explained.

Referring to Fig. 13, turning the motor 83 on sets the cross-flow fan 82 revolving.

When the control vane 96 is directed to the left as shown in Fig. 15, a low-pressure voltex V of the cross-flow fan 82 is not only generated on the inner side of the control vane but also confined therein. Accordingly, the flow on the outer side of the control vane 96 is such that the fluid is sucked from A discharged into B of the two regions defined by said first and second partitioning members 86 and 87. Thus, it is a horizontal flow from G to H.

Now, the dial 103 is rotated to bring the control vane 96 in a downwardly facing position as illustrated in Fig. 16. Then, the low-pressure voltex V of the cross-flow fan 82 is shifted downwards in response to the movement of the control vane 96. Accordingly, the flow of fluid on the outer side of the control vane 96 is such that the fluid is sucked from A and discharged into B of the two regions defined by said first and second partitioning members 86 and 87. Thus, it is a downward flow from I to J.

Now, the dial 103 is rotated to set the control vane 96 in a right-facing position as shown in Fig. 17. With the shift of the control vane 96, the low-pressure voltex V of the cross flow fan 82 is shifted to the right. The flow on the outer side of the control vane 96 is such that the fluid is sucked from B and discharged into A

of the two regions defined by said first and second partitioning members 86 and 87.

5 Figs. 15 and 16 show the horizontal and downward flows but it is apparent that an optional direction of flow can be selected by choosing the proper position of control vane 96 as the vane is capable of restricting the low-pressure voltex V.

10 In order to promote a horizontal or downward deflection of flow, it is possible to enlarge the deflection angle due to an adhesion effect by extending the length L_u of the first partitioning member 86 or the length L_d of the second partitioning member 87 to the left or downwards as the case may be.

15 Thus, reversal of flow and control of the direction of flow are enabled by mere rotation of the control vane 96.

INDUSTRIAL APPLICABILITY

20 It will be apparent from the foregoing description that since the fluid deflecting apparatus according to this invention is such that the low-pressure voltex of the cross-flow fan can be controlled only with a control vane disposed within the fan, deflection control over the range of 360 degrees can be accomplished in a compact arrangement without inducing changes in wind
25 volume, noise and other characteristics.

Moreover, when the space external of the fan is

divided into two regions by two partitioning members
in the radial direction of the fan, a switching of flow
direction between the two regions can be easily accomplished
by mere rotation of the control vane located within the
5 fan.

In addition, by inclining the side portion of the
partitioning member inwardly with respect to the outer
circumference of the fan, the formation of the low-
pressure vortex can be further promoted to provide a
10 more stabilized flow.

Or, by providing said partitioning member with
a substantially arcuate recess in correspondence with
the fan, confinement of the low-pressure vortex can be
further assisted so as to provide a stabilized flow.

15 Moreover, by disposing one of the partitioning
members external of the fan in a radial direction and
the other in a tangential direction, the direction of
flow between two regions external of the fan can be
easily switched from one to the other by mere rotation of
20 the control vane disposed within the fan.

Furthermore, the above construction enables one not
only to change the direction of flow but also to control
the direction of flow over the whole range from the
direction along the first partitioning member through
25 the direction along the second partitioning member.

Moreover, by extending the length of such partitioning
member in the discharge direction, the adhesion effect

of flow can be obtained to provide a positive broad-angle deflection of flow.

CLAIMS:

1. A fluid deflecting apparatus for a fan equipment including a cross-flow fan and a motor, characterized by comprising a control vane as disposed within said fan, said control vane having a substantially arcuate cross-section and an included angle such that a low-pressure voltex as generated by rotation of said cross-flow fan is restricted thereby and being rotatably constructed, whereby the position of said low-pressure voltex may be adjusted to control the direction of flow passing through said cross-flow fan.

2. A fluid deflecting apparatus according to Claim 1 wherein both ends of the cross-section of said control vane are located near the inner circumference of said cross-flow fan.

3. A fluid deflecting apparatus according to Claim 1 wherein the axis of rotation of said control vane is coincidental with the axis of rotation of said cross-flow fan.

4. A fluid deflecting apparatus according to Claim 1 wherein supports of said control vane are displaced from axis of rotation of said control vane.

5. A fluid deflecting apparatus according to Claim 1 wherein the rotary shaft of said control vane is secured as extending through end plates of said cross-flow fan.

6. A fluid deflecting apparatus according to Claim 1 wherein a first and a second partitioning member are

provided to divide a space outside of the cross-flow fan into two regions.

7. A fluid deflecting apparatus according to Claim 6 which is further characterized in that said
5 first and second partitioning members are disposed in substantially juxtaposed positions in the radial direction of the cross-flow fan.

8. A fluid deflecting apparatus according to Claim 7 wherein said first and second partitioning members are
10 substantially plano-configured.

9. A fluid deflecting apparatus according to Claim 7 wherein each of said first and second partitioning members has an inclined surface with respect to the cross-flow fan so as to constrict the width of flow
15 passage in the direction of rotation of the fan.

10. A fluid deflecting apparatus according to Claim 7 wherein each of said first and second partitioning members has a substantially arcuate recess on the cross-flow fan side.

20 11. A fluid deflecting apparatus according to Claim 6 wherein said first partitioning member and second partitioning member are disposed in substantially radial and substantially tangential directions, respectively.

25 12. A fluid deflecting apparatus according to Claim 11 wherein each or either one of said first and second partitioning members is formed so that its length is sufficient to provide an adhesion of flow.

- 1, + 2

Fig. 1

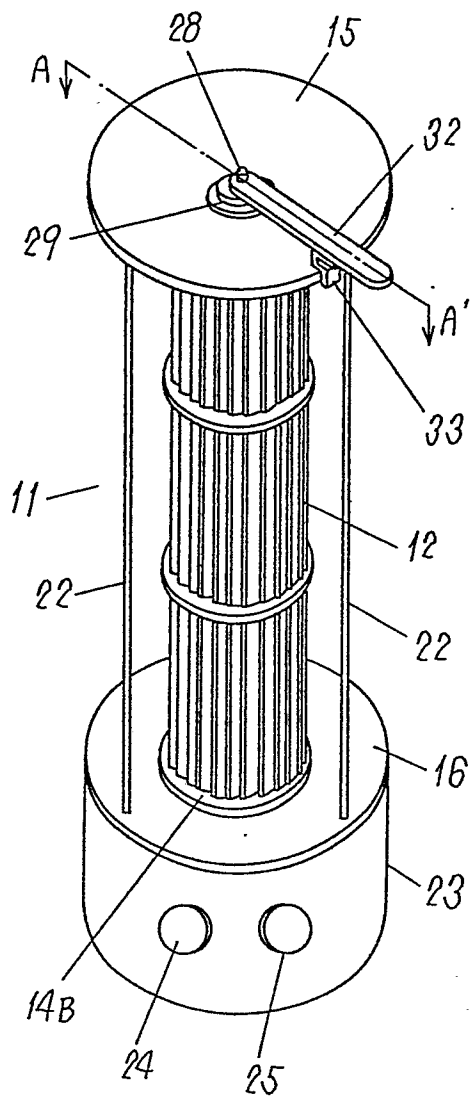
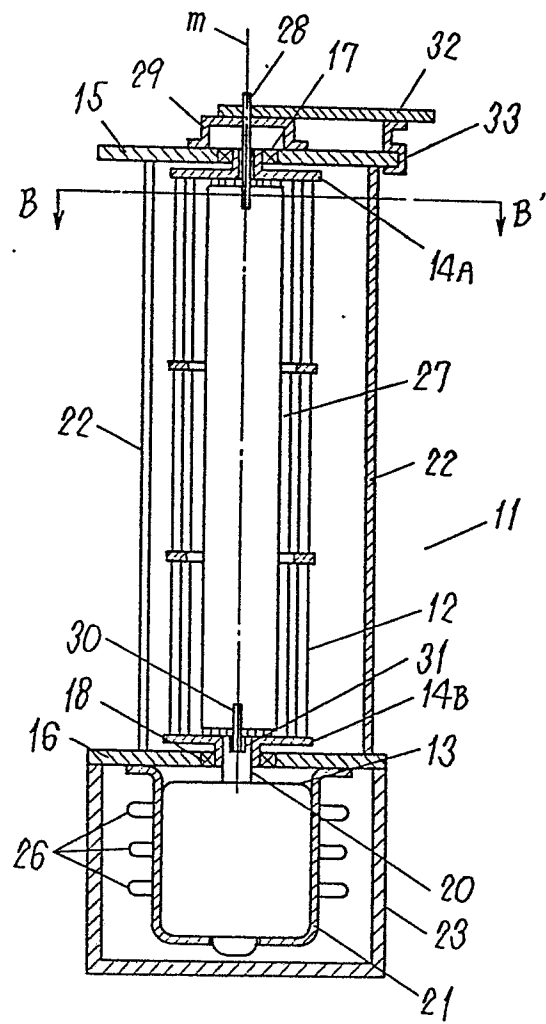

Fig. 2



- 2 / 12

Fig. 3

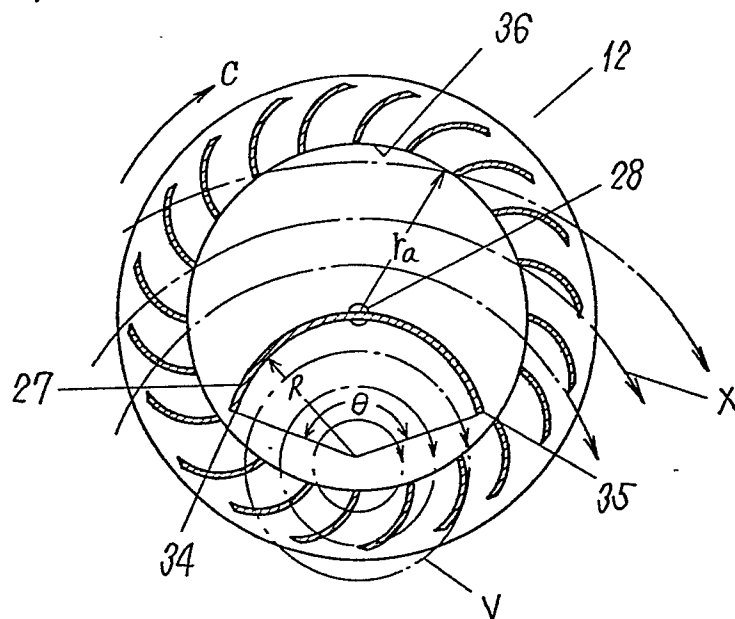
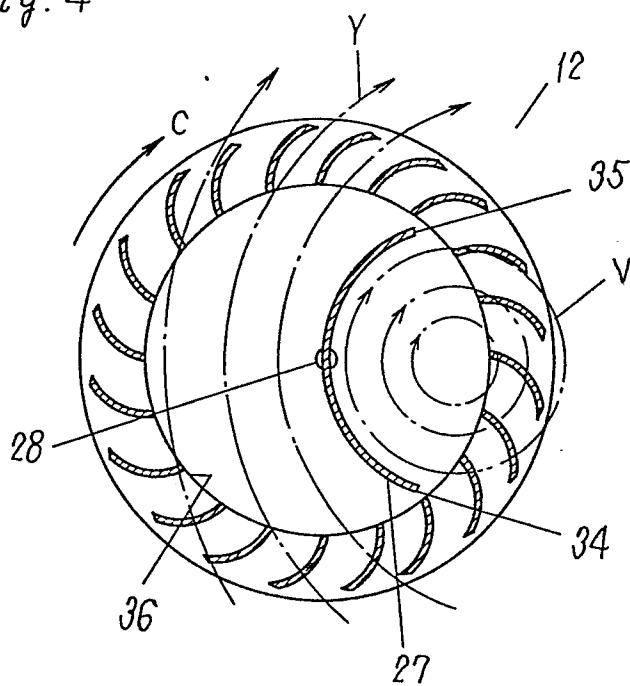

Fig. 4



- 3/+2

Fig. 5

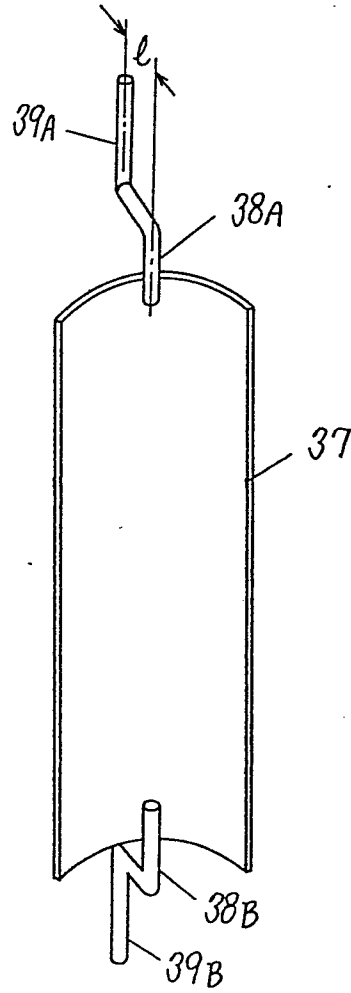
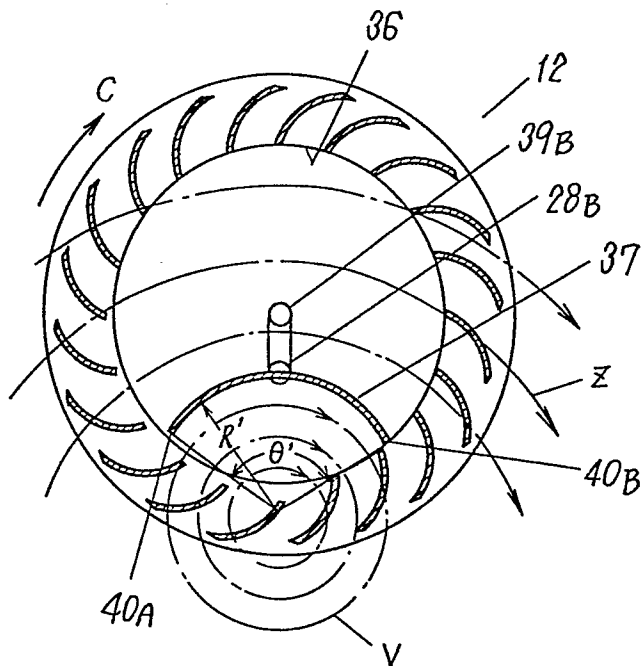

Fig. 6



- 4/12

Fig. 7

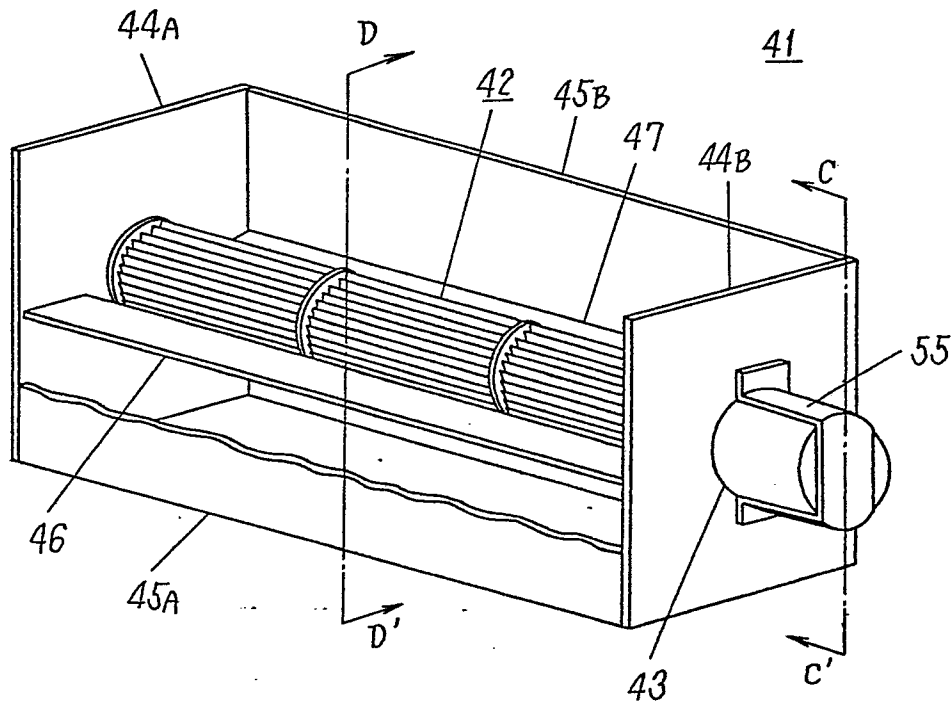
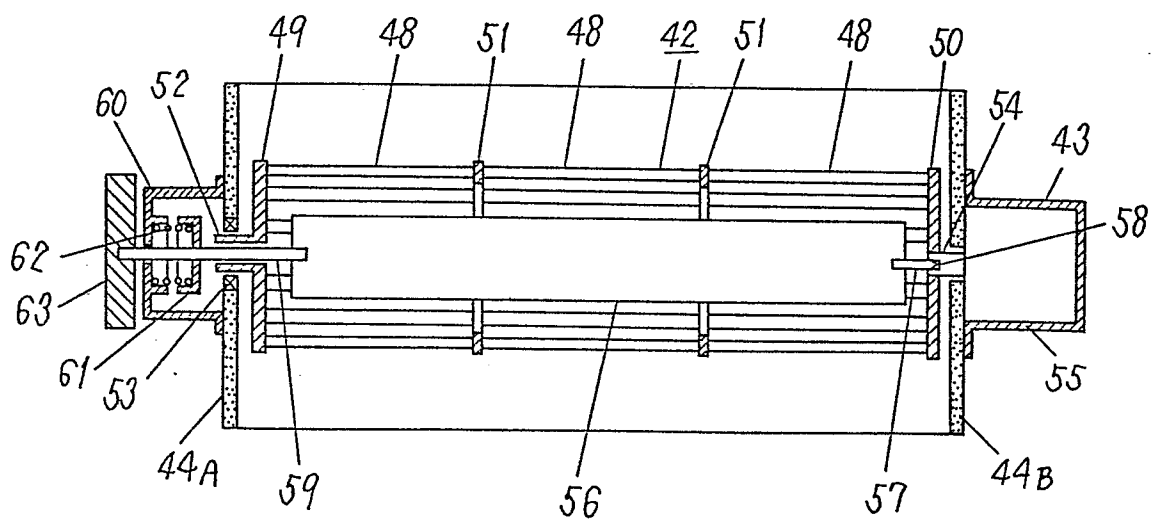

Fig. 8



- 5/+2

Fig. 9

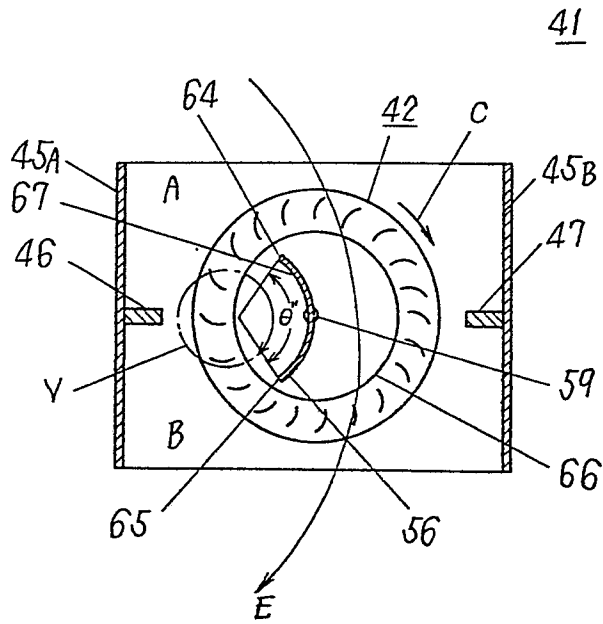
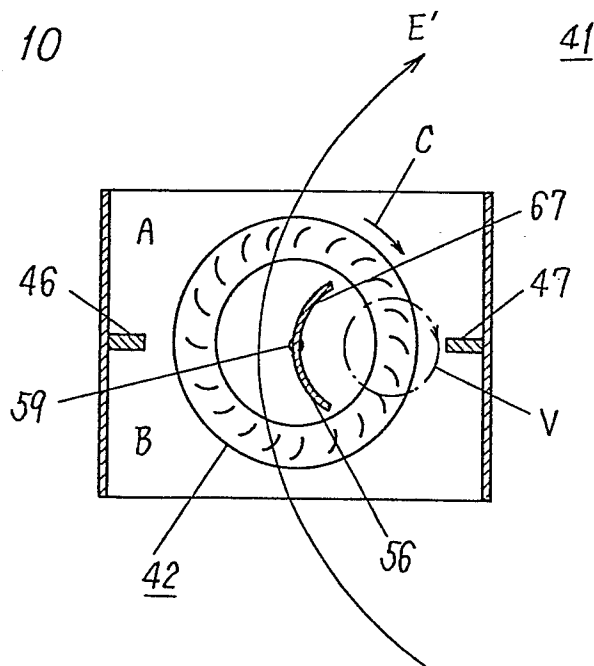

Fig. 10



- 6 / 12

Fig. 11

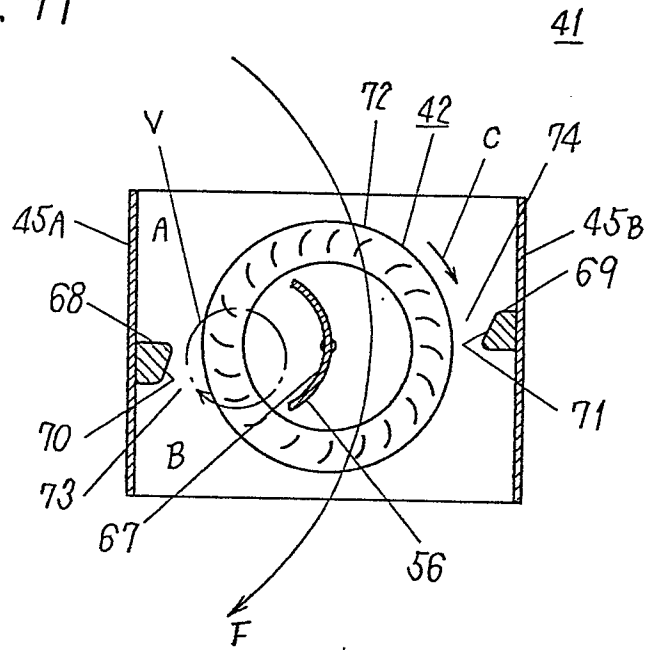
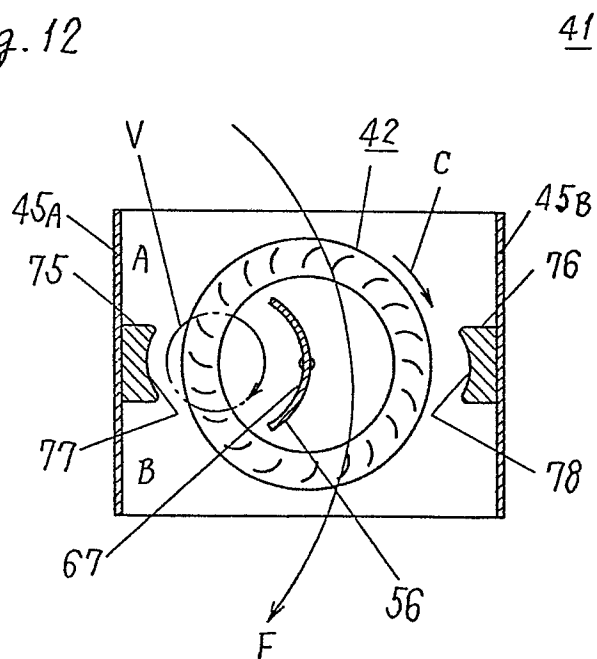

Fig. 12



- 7 / 2

Fig. 13

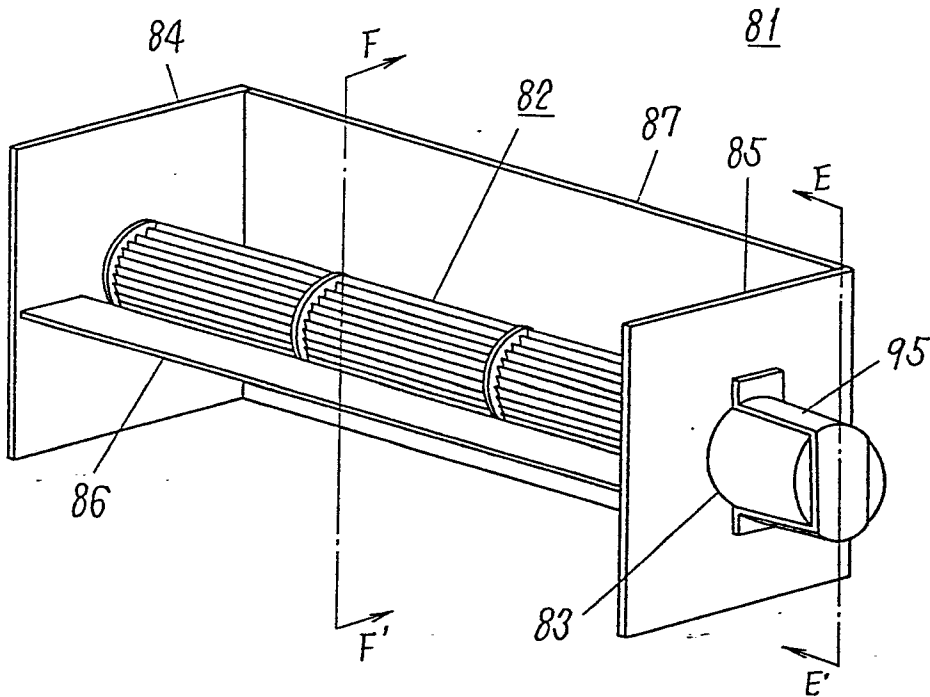
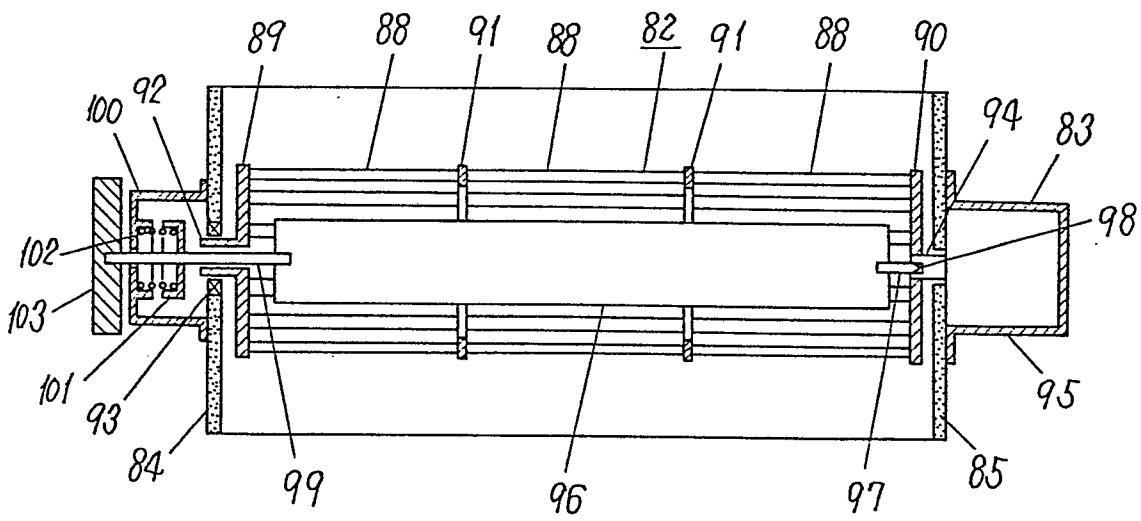

Fig. 14



- 8 / 12

Fig. 15

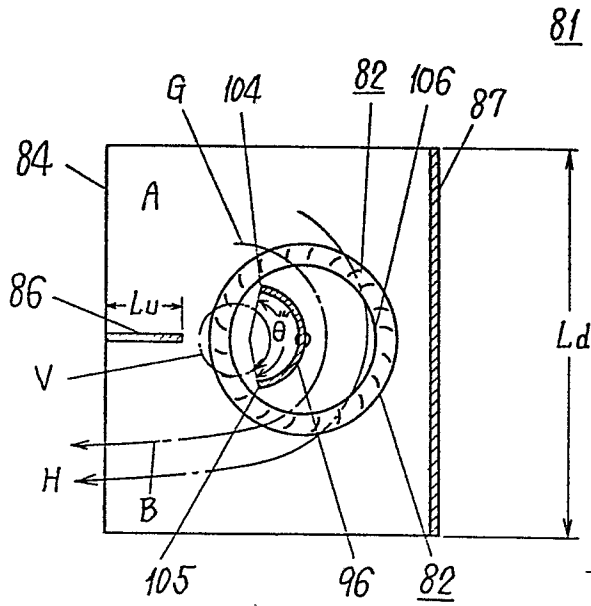

Fig. 16

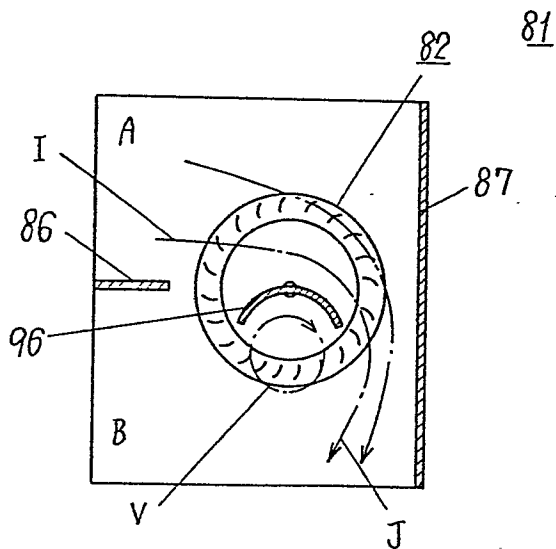
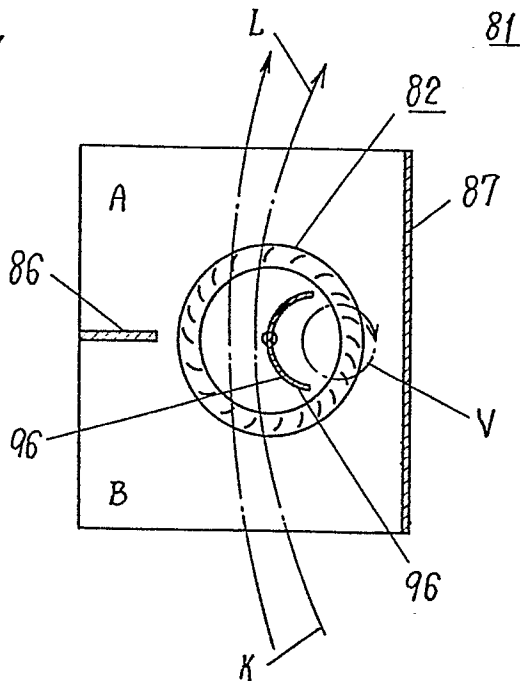

Fig. 17



9/12

LIST OF REFERENCE LEGENDS ON THE DRAWINGS

11...Fluid deflecting apparatus

12...Cross-flow fan

13...Motor

14A, 14B...End plates

15...Side plate

16...Side plate

17...Bearing

18...Bearing

20...Shaft

21...Motor support member

22...Post

23...Casing

24...Dial

25...Dial

26...Opening

27...Control vane

28...Rotary shaft

29...Retaining plate

30...Rotary shaft

32...Lever

33...Engaging member

34...End of arc

35...End of arc

36...Inner circumference

37...Control vane

38A, 38B...Support portions

39A, 39B...Rotary shafts
40A, 40B...Ends of arc
41...Flow deflecting apparatus
42...Cross-flow fan
43...Motor
44A, 44B...Side plates
45A, 45B...Retaining plates
46...Partitioning member
47...Partitioning member
48...Blades
49...End plate
50...End plate
51...Intermediate plate
52...Cylindrical portion
53...Bearing
54...Shaft
55...Part
56...Control vane
57...Shaft
58...Recess
59...Bearing
60...Support plate
61...Spring retaining plate
62...Spring
63...Dial
64...End of arc
65...End of arc

66...Inner circumference
67...Recess
68...Partitioning member
69...Partitioning member
70...Side portion
71...Side portion
72...Outer circumference
73...Flow passage
74...Flow passage
75...Partitioning member
76...Partitioning member
77...Recess
78...Recess
82...Cross-flow fan
83...Motor
84...Side plate
85...Side plate
86...Partitioning member
87...Partitioning member
88...Blades
89...End plate
90...End plate
91...Intermediate plate
92...Cylindrical portion
93...Bearing
94...Shaft
95...Member

12/12

- 96...Control vane
- 97...Rotary shaft
- 98...Recess
- 99...Rotary shaft
- 100...Support plate
- 101...Spring retainer
- 102...Spring
- 103...Dial
- 104...End of arc
- 105...End of arc
- 106...Inner circumference

INTERNATIONAL SEARCH REPORT

0067884

International Application No

PCT/JP81/00400

I. CLASSIFICATION OF SUBJECT MATTER (if several classification symbols apply, indicate all) ³		
According to International Patent Classification (IPC) or to both National Classification and IPC		
Int. Cl. ³ F04D 17/04		
II. FIELDS SEARCHED		
Minimum Documentation Searched ⁴		
Classification System	Classification Symbols	
IPC	F04D 17/04	
Documentation Searched other than Minimum Documentation to the extent that such Documents are Included in the Fields Searched ⁵		
Jitsuyo Shinan Koho	1926 - 1981	
Kokai Jitsuyo Shinan Koho	1971 - 1981	
III. DOCUMENTS CONSIDERED TO BE RELEVANT ¹⁴		
Category [*]	Citation of Document, ¹⁶ with indication, where appropriate, of the relevant passages ¹⁷	Relevant to Claim No. ¹⁸
X	US, A, 3,263,910 (Bruno Eck and Nikolaus Laing), 2, August, 1966 (02.08.66)	1-3, 5
Y	JP, Y2, 52-16417 (Sanyo Electric Co., Ltd.) 13, April, 1977 (13.04.77)	6 - 9
Y	JP, Y1, 42-17237 (Mitsubishi Electric Corp.) 4, October, 1967 (04.10.67)	10
Y	JP, A, 52-67010 (Royal Denki Kabushiki Kaisha), 3, June, 1977 (03.06.77)	11, 12
	<p>"X" document of particular relevance; the claimed invention cannot be considered novel or cannot be considered to involve an inventive step</p> <p>"Y" document of particular relevance; the claimed invention cannot be considered to involve an inventive step when the document is combined with one or more other such documents, such combination being obvious to a person skilled in the art</p>	
<p>* Special categories of cited documents: ¹⁵</p> <p>"A" document defining the general state of the art</p> <p>"E" earlier document but published on or after the international filing date</p> <p>"L" document cited for special reason other than those referred to in the other categories</p> <p>"O" document referring to an oral disclosure, use, exhibition or other means</p> <p>"P" document published prior to the international filing date but on or after the priority date claimed</p> <p>"T" later document published on or after the international filing date or priority date and not in conflict with the application, but cited to understand the principle or theory underlying the invention</p> <p>"X" document of particular relevance</p>		
IV. CERTIFICATION		
Date of the Actual Completion of the International Search ¹		Date of Mailing of this International Search Report ²
March 19, 1982 (19.03.82)		March 29, 1982 (29.03.82)
International Searching Authority ¹		Signature of Authorized Officer ²⁰
Japanese Patent Office		