

⑫ **EUROPEAN PATENT APPLICATION**

⑰ Application number: 82201154.0

⑤① Int. Cl.³: **B 30 B 15/28, B 30 B 11/20**

⑱ Date of filing: 17.09.82

③④ Priority: 21.09.81 NL 8104343

⑦① Applicant: **Treurniet, Nicolaas Cristiaan, Meerweg 27, NL-2651 KR Berkel en Rodenrijs (NL)**

④③ Date of publication of application: 30.03.83
Bulletin 83/13

⑦② Inventor: **Treurniet, Nicolaas Cristiaan, Meerweg 27, NL-2651 KR Berkel en Rodenrijs (NL)**

⑧④ Designated Contracting States: **BE DE FR GB IT NL**

⑦④ Representative: **Urbanus, Henricus Maria, Ir. et al, c/o Verenigde Octroobureaux Nieuwe Parklaan 107, NL-2587 BP 's-Gravenhage (NL)**

⑤④ **A method and apparatus for protecting a fodder press against jamming.**

⑤⑦ A method and apparatus for protecting a fodder press against jamming, comprising a press chamber (2) having a rotary die (6) and a plurality of pressure rolls (3-5) positioned within the die and each rotatable about a shaft, a motor (9) for driving the die, as well as a door (10) provided before the press chamber, said door being coupled to a supply opening for raw material, while there are provided means for measuring the electric current flowing towards the motor, means (21) for generating a control signal when a predetermined current value is exceeded and means (14) for opening upon command of said control signal the door (10) positioned before the press chamber (2).

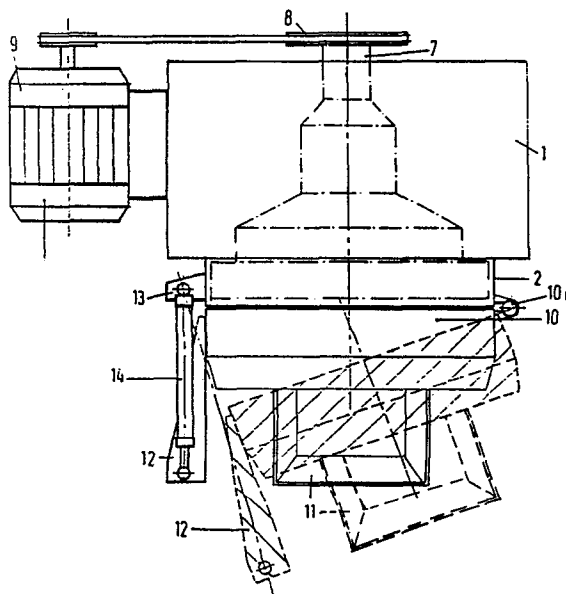

A method and apparatus for protecting a fodder press against jamming.

The invention relates to a method and apparatus for protecting a fodder press against jamming, said press comprising a press chamber having a rotary die and a plurality of pressure rolls positioned within the die and each being rotatable about a shaft, a motor for driving the die, as well as a door disposed before the press chamber and
5 which is coupled to a supply opening for raw material.

Such a fodder press is disclosed in Dutch patent application 281.048. Before the raw material, such as ground fodder, is supplied to the press, said raw material is mixed with steam. The steam
10 provides on the one end a lubricating effect during the pressing through the die and on the other end provides a sufficient binding force to the lump eventually formed from the ground fodder. The supply of steam should be carefully adjusted to the nature and the quantity of the raw material in order to ensure that the pressing through the die
15 takes place with optimally low energy consumption and an optimally high production. If excessive steam in relation to a given quantity of raw material is supplied, the fodder in the press will obtain a gelatin form and this gelatin formation will block the press, which will increasingly load the drive motor and likewise lead to a
20 substantially lower efficiency. If no reduction of steam supply or increase in the quantity of supplied raw material takes place, the formation of gelatin will continue to increase until the press automatically stops since the maximum motor power is exceeded. In practice it is found that the protection of the motor often reacts
25 even so slowly that the driving belts for the press burn out before the motor stops. After the jamming of the press, the space containing the pressure rolls and the die has to be cleaned before the press can be put in operation again.

It has already been proposed to prevent the jamming by detecting
30 the formation of gelatin in a very early stage and subsequently to stop the supply of raw material, for instance by automatically closing a valve in the supply opening of the raw material. However, it has been found that the jamming process takes place so rapidly that the

quantity of raw material still present upon the closure of such a valve between said valve and the press chamber is sufficient to produce a complete jamming of the press, so that the press will still have to be stopped and cleaned.

5 It is the object of the invention to provide a method and an apparatus for protecting a fodder press against jamming, said method being highly reliable and said apparatus being adapted to be simply applied without high cost on existing presses.

10 The invention to this effect provides a method of protecting a fodder press of the above mentioned type against jamming, in which the magnitude of the electric current flowing to the motor is measured and when a predetermined current value is exceeded a control signal is produced, while upon command of the control signal means are set in operation for opening the door positioned before the press chamber.

15 The invention likewise provides an apparatus for performing the method according to the invention, there being provided means for measuring the electric current flowing to the motor, means for supplying a control signal when a predetermined current value is exceeded and means for opening upon command of said control signal the door positioned
20 before the press chamber.

 It has been found that the jamming of a fodder press by means of the features according to the invention can be completely prevented. When the fodder press threatens to become jammed, the motor power input, and hence the current flowing to the motor, rapidly increases. This
25 current increase can be detected and upon excess of a predetermined value, a control signal for opening the door can be generated. Since the door positioned before the press chamber is opened, in which door there is provided the supply opening for raw material, the supply of even the smallest quantity of raw material is prevented, while likewise the loose
30 raw material still present in the press chamber can fall out of the machine. The pressure rolls press the other raw material still present, which did not fall out of the press chamber, through the die. It is supposed that not only the complete stopping of the supply of raw material is favourable to prevent further gelatin formation, but that
35 likewise the sudden entry of relatively cool ambient air into the press chamber

favourably affects the processing by the pressure rolls of the raw material still present.

One embodiment of the invention will now be described, by way of example, with reference to the accompanying drawing, in which:

5 fig. 1 is a partially exploded front view of a fodder press provided with the apparatus according to the invention;

 fig. 2 is a top view of the press according to fig. 1, in which the door is shown in a closed and an opened position and

10 fig. 3 is a diagrammatic view of the control circuit for the apparatus according to the invention.

 Figures 1 and 2 show a fodder press comprising a housing 1 having at its front a press chamber 2 with mounted therein three pressure rolls 3, 4 and 5, each being rotatable about a stationary shaft. The pressure rolls coact with the inside of a perforated
15 annular die 6 enclosing said rolls, which die is mounted on the one end of a hollow rotatably mounted shaft 7, which at the other end carries a drive disk 8. The drive disk 8 is coupled to the drive motor 9 via a belt. Before the die 6 there is attached to the housing a door 10 which is adapted for rotation about a pivot 10a. The supply of raw
20 material to the press chamber takes places via a suitable opening in the door through a supply 11. According to the invention, the door is provided with an extended attachment member 12 and the housing is provided with an attachment point 13 situated beside the press chamber at the exterior of the housing. Between the free end of the attachment
25 member 12 and the attachment point 13 there is provided an air cylinder 14 which is extended upon command of a control signal and being adapted to displace the door 10 from the closed position shown in fig. 2 in full lines towards the open position shown in dotted lines. In addition to an air cylinder, naturally also other members may be used
30 which under influence of a control signal ensure the required displacement of the door.

 Fig. 3 diagrammatically shows an electric circuit for generating the control signal for the air cylinder 14. To one of the feed line T of the motor 9, which in the case shown is connected to a three-phase
35 (R, S, T) supply voltage, there is coupled a transducer 20 which is

connected to a device 21. The device 21 is adapted to produce a control signal when a predetermined adjustable current flows through the line T. Such a device 21 may for instance be a contact ammeter having an adjustable response value, as marketed under the tradename Fotact. The control signal of the device 21 is supplied to a relay 22 a contact 22a of which is incorporated in the feed line for the air cylinder 14, which is diagrammatically shown. When the relay 22 under influence of the control signal of the device 21 is responsive, the contact 22a is closed and the cylinder is energized in such a way that the door 10 of the press is opened.

The method according to the invention is performed as follows. The device 21 is set in such a way that it produces a control signal when a predetermined current value is exceeded, e.g. at a value which is 20% higher than the value upon normal operation. This current value is chosen in such a way that at the current value set precisely an initial gelatin formation in the press chamber 2 occurs. When the current value set is exceeded, the device 21 produces the control signal and the air cylinder 14 is energized through relay contact 22a and opens the door 10 of the press. All the raw material still present in the supply 11 and at the inside of the door falls downwardly and can no longer reach the press chamber 2. The loose, raw material still present in the press chamber 2 can also fall out of the press chamber, while the raw material still present between the pressure rolls and the die is pressed through the die, so that the press therefore is completely self-cleaned without human intervention.

When the door is opened an alarm signal is produced on behalf of an operator, while naturally also the supply of raw material is stopped. After the press has cleaned itself in the above described manner, the door is closed by the operator, the steam supply is slightly reduced, the press is put in operation and the supply of raw material is resumed. The protection against jamming according to the invention is therefore effected completely automatically, while the replacing in operation of the press can take place very quickly, since the time-consuming manual cleaning of the press chamber is superfluous.

It will be clear that a great many modifications are possible

within the scope of the invention. For instance, instead of one cylinder two cylinders may be applied, while the door of the press no longer rotates about a fixed point but is advanced by cylinders on either side of the door parallel to the front face of the press. Since in such a case a uniform displacement of the door is highly important, preferably so-called electrocylinders are employed which are provided with a threaded drive shaft and a motor for moving such shaft.

The invention is not restricted either to the type of press described in the embodiment but may also be applied with other press types.

C L A I M S

1. A method for protecting a fodder press against jamming, comprising a press chamber having a rotary die and a plurality of pressure rolls positioned within the die, each rotating about a shaft, a motor for driving the die, as well as a door positioned before the press chamber,
5 said door being coupled to a supply opening for raw material, characterized in that the magnitude of the electric current flowing towards the motor is measured and when a predetermined current value is exceeded a control signal is generated and that upon command of the control signal means are set in operation for opening the door positioned before the
10 press chamber.
2. A method according to claim 1, characterized in that the door is opened at a speed larger than about 0.3 m/sec.
3. A method according to claim 1 or 2, characterized in that the door is opened by means of an air cylinder.
- 15 4. An apparatus for protecting a fodder press against jamming, comprising a press chamber having a rotary die and a plurality of pressure rolls positioned within the die, each rotating about a shaft, a motor for driving the die, as well as a door positioned before the press chamber, said door being coupled to a supply opening for raw
20 material, characterized in that there are provided means for measuring the electric current flowing towards the motor, means for generating a control signal when a predetermined current value is exceeded and means for opening upon command of said control signal the door positioned before the press chamber.
- 25 5. An apparatus according to claim 4, characterized in that the means for opening the door comprise an air cylinder.
6. An apparatus according to claim 4, characterized in that the means for opening the door comprise an electrocylinder.
7. An apparatus according to claim 4 or 5, characterized in that the
30 means for measuring the current flowing towards the motor comprise a contact ammeter.

FIG. 1

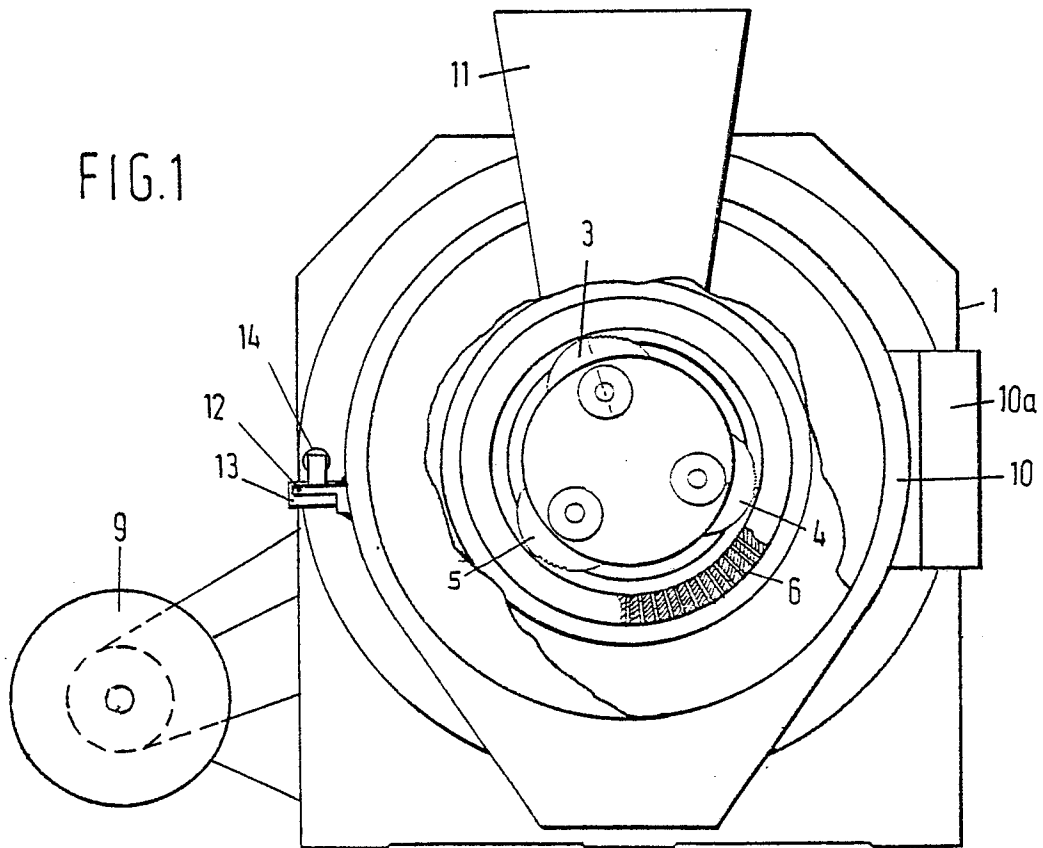

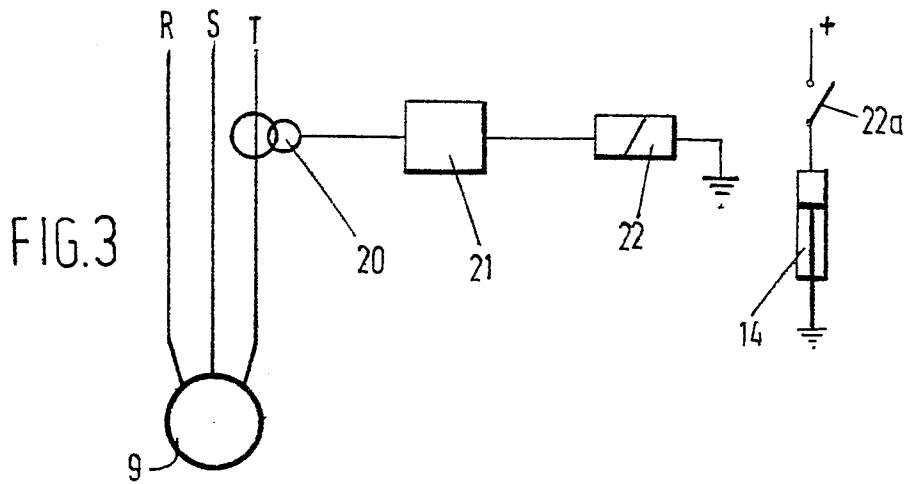
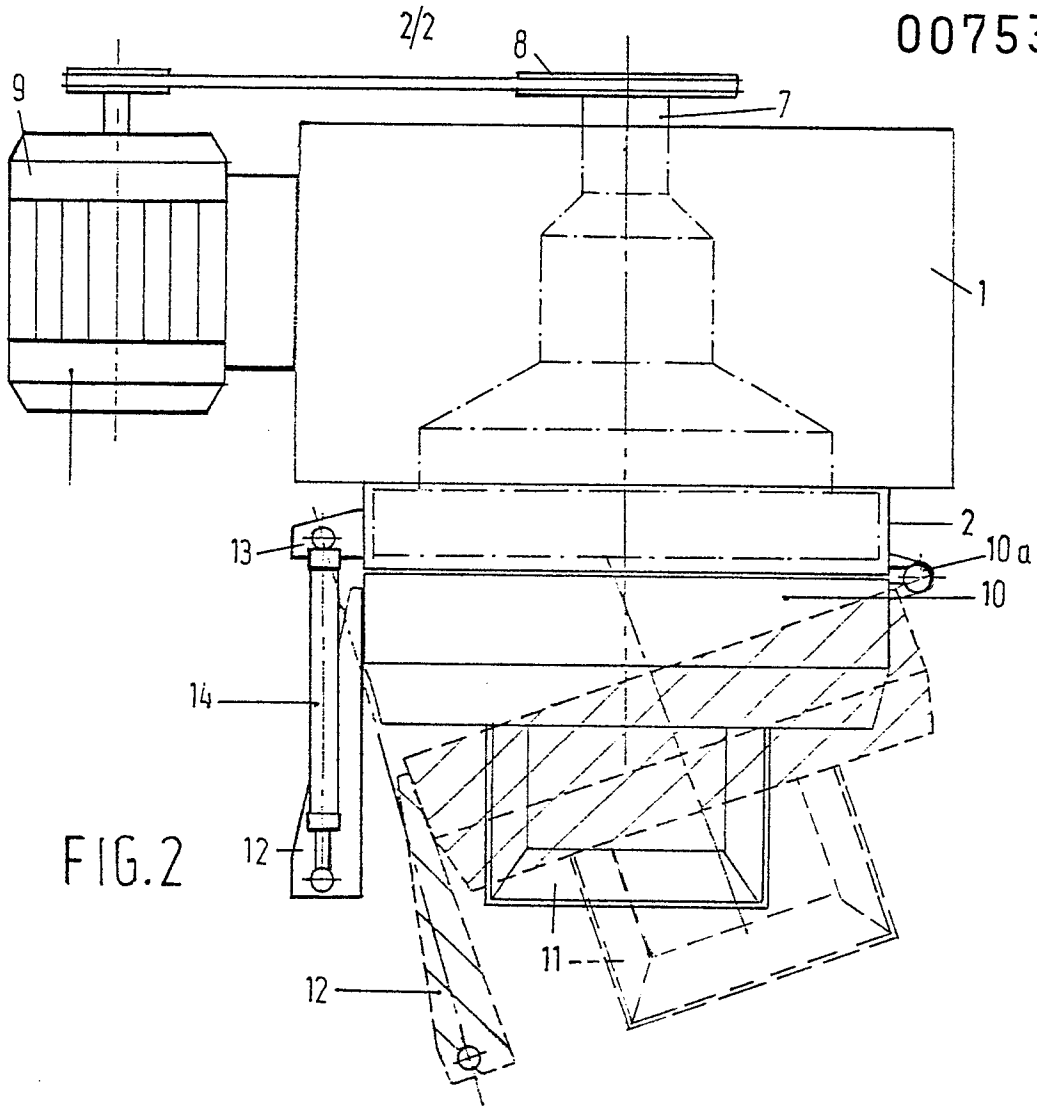



European Patent
Office

EUROPEAN SEARCH REPORT

0075370

Application number

EP 82 20 1154

DOCUMENTS CONSIDERED TO BE RELEVANT			
Category	Citation of document with indication, where appropriate, of relevant passages	Relevant to claim	CLASSIFICATION OF THE APPLICATION (Int. Cl. 3)
A	<p style="text-align: center;">---</p> FR-E- 89 484 (GEBR. BÜHLER) *Page 3, left-hand column, line 58 to right-hand column, line 6; figure 2*	1,4	B 30 B 15/28 B 30 B 11/20
A	<p style="text-align: center;">---</p> US-A-3 167 813 (J.T.KEEFE) *Column 2, line 6-18; figure 3*	1,4	
A	<p style="text-align: center;">---</p> DE-B-1 211 908 (EISENWERK WESERHÜTTE) *The whole document*	1,3-5	
A	<p style="text-align: center;">---</p> DE-A-2 013 272 (MASCHINENFABRIK WEINGARTEN) *The whole document*	1,4	
A	<p style="text-align: center;">---</p> GB-A-1 249 265 (VEB KOMBINAT FORTSCHRITT LANDMASCHINEN NEUSTADT) *Claim 1; figures 1,2*	1,4	TECHNICAL FIELDS SEARCHED (Int. Cl. 3) B 30 B B 02 C

The present search report has been drawn up for all claims			
Place of search THE HAGUE		Date of completion of the search 17-12-1982	Examiner BOLLEN J.A.G.
CATEGORY OF CITED DOCUMENTS X : particularly relevant if taken alone Y : particularly relevant if combined with another document of the same category A : technological background O : non-written disclosure P : intermediate document		T : theory or principle underlying the invention E : earlier patent document, but published on, or after the filing date D : document cited in the application L : document cited for other reasons & : member of the same patent family, corresponding document	

EPO Form 1503 03/82