

⑫

EUROPEAN PATENT SPECIFICATION

④⑤ Date of publication of patent specification: **15.05.85**

⑤① Int. Cl.⁴: **B 22 D 7/10**

②① Application number: **82304235.3**

②② Date of filing: **11.08.82**

⑤④ **Hot tops.**

③⑧ Priority: **23.09.81 GB 8128713**

④③ Date of publication of application:
13.04.83 Bulletin 83/15

④⑤ Publication of the grant of the patent:
15.05.85 Bulletin 85/20

⑧④ Designated Contracting States:
AT BE CH DE FR GB IT LI LU NL SE

⑤④ References cited:
DE-U-7 119 091
GB-A-1 255 938
GB-A-2 077 160

⑦③ Proprietor: **FOSECO TRADING A.G.**
Gartenstrasse 2 P.O. Box 235
CH-6300 Zug (CH)

⑦② Inventor: **Comes, Heinrich**
Boomkamp 20
D-4280 Borken 3-Weseke (DE)
Inventor: **Friede, Klaus**
Loefflerstrasse 15
D-4223 Voerde 2 (DE)

⑦④ Representative: **Warman, Charles Alfred**
Group Patents Department Foseco Minsep
International Limited 285 Long Acre
Nechells Birmingham B7 5JR (GB)

EP 0 076 564 B1

Note: Within nine months from the publication of the mention of the grant of the European patent, any person may give notice to the European Patent Office of opposition to the European patent granted. Notice of opposition shall be filed in a written reasoned statement. It shall not be deemed to have been filed until the opposition fee has been paid. (Art. 99(1) European patent convention).

Description

The invention concerns hot tops for metallurgical moulds, in particular for ingot moulds, especially for casting steel.

In casting steel ingots it is desirable to keep the metal in the head of the mould molten whilst the metal in the body of the mould is cooling and solidifying, because the metal in the body of the mould shrinks as it cools and solidifies and, if the head metal is kept molten, the head metal feeds down into the ingot body and achieves the desirable effect of inhibiting the formation of shrinkage cavities in the body of the ingot. The head metal may be kept molten by use of a hot top and this may comprise a number of refractory, heat-insulating articles e.g. slabs positioned as a lining in the head of the mould or in a separate head box at the top of the mould, in the latter case the head metal being within the head box.

Originally hot top linings were commonly of firebrick, usually with a density of about 2 to 3 g/cm³. Firebrick is not a good heat-insulator and for this reason the firebrick linings were thick e.g. 75 mm. However the thick firebrick linings were of high thermal capacity and therefore exerted a marked and undesirable initial chilling effect on the head metal.

The chilling effect mentioned above and other disadvantages of firebrick hot top linings were greatly reduced or eliminated by the subsequent development of slurry-formed, expendable hot top lining articles having good heat-insulating properties and low densities, typically about 1.1 g/cm³. The good heat-insulating properties of such articles mean that adequate heat-insulation is provided by a much thinner lining, typically 30 mm, compared with firebrick linings.

Partly because the known slurry-formed, expendable lining articles are thin and partly because of the thermal properties of the materials of the articles, such linings are of low thermal capacity and therefore exert only a small initial chilling effect on the head metal. The chilling effect of such linings is minimised by making the linings as thin as is compatible with providing the required heat-insulation and mechanical strength. In any event the dewatering and drying steps necessary in making the slurry-formed articles become considerably more difficult if the thickness of the article is significantly greater than 30 mm. Moreover, if the articles are made thicker, they become heavier and less easily handled.

DE—U—7119091 discloses a hot top lining slab of refractory, heat-insulating material having a plurality of ribs at a vertical end face defining a plurality of recesses.

According to the invention a hot top lining slab of refractory, heat-insulating material having a plurality of ribs at a face of the slab defining a plurality of recesses is characterised in that the refractory, heat-insulating material is slurry-formed, the slab has a density in the range of 0.3 to 0.85 g/cm³ and an average overall thickness of at least 40 mm and the ribs are at the back i.e.

outer face of the slab and define enclosed recesses spaced inwardly from the periphery of the slab. In use the slabs are positioned with the recessed face outwards i.e. away from the molten metal.

It has been found in accordance with the invention that the particular combination of features specified enables a very desirable combination of advantages to be obtained.

The fact that the slabs are slurry-formed is a manufacturing convenience and, as part of the thickness of the slabs is accounted for by the ribs, the slabs do not present the dewatering and drying difficulties that would arise if the slabs were of the same overall thickness but did not have the recesses.

The great thickness of the slabs enables an excellent heat-insulating effect to be achieved, an effect enhanced by the air in the recesses. Furthermore, good heat-insulating properties are associated with the low density of the slabs. Despite the thickness of the slabs, a very small initial chilling effect is suffered as the material of the slabs is itself of low thermal capacity, a factor associated with the low density of the slabs.

The fact that the slabs are of low density material coupled with the presence of the recesses means that, despite their thickness, the slabs are not heavy and they can easily be handled. Also, the presence of the ribs serves to increase the mechanical strength of the slabs whilst not greatly increasing their thermal capacity. This combination of properties is especially valuable as the strength of slurry-formed refractory, heat-insulating slabs tends to decrease with a decrease in density.

In casting steel ingots it was widely accepted for many years that all the head metal should be discarded and therefore an important objective was to minimise the ratio of metal in the head of the ingot to metal in the body of the ingot (subject to the requirement that the body of the ingot should be sound) in order that the proportion of cast metal discarded should be as low as possible. More recently this objective has been somewhat modified and hot top linings have been designed so that some of the head metal should be usable. However, hot top linings commonly result in the formation of ingots with a shoulder where the head metal adjoins the body of the ingot and, if the head metal is not entirely discarded, the shoulder can result in defects in the steel after the ingot has been rolled. Such defects are minimised if the shoulder is slight and this factor has favoured the use of thin hot top linings. The present invention contrasts with this approach: the thick slabs enable the proportion of head metal to be decreased. Preferably the average overall thickness of the slabs is at least 50 mm.

In the slabs of the invention the ribs preferably account for at least 30%, e.g. about 50%, of the overall thickness of the slab. The ribs preferably define at least three recesses and the total area of the recesses at the outer face of the slab is

preferably at least 30% of the total area of the outer surface of the slab. Some or all of the ribs, especially those separating adjacent recesses, preferably taper outwardly. The tapered ribs are preferably at least twice as wide at the base as at the tip. The preferred features just described characterise slabs of the invention with especially valuable thermal and mechanical properties and which are easy to make and handle.

The recesses may be of various shapes preferably generally rectangular.

The slabs may be slurry-formed in known manner using known materials and using a former shaped to form the slabs with the ribs and recesses. The ingredients of the slab comprise particulate refractory filler, some at least of which is lightweight e.g. has a bulk density not greater than 0.35 g/cm³, a binder and, optionally, organic and/or inorganic fibres. Preferably the lightweight filler is one or more of calcined rice husks and expanded minerals, e.g. expanded perlite. The density of the slab is most preferably 0.4 to 0.7 g/cm³.

An edge of the slab (the lowermost edge in use) is preferably bevelled so that the molten metal contacting face of the slab does not extend downwards as far as the opposite face of the slab. Preferably the bevelled edge is generally concave and the concavity is preferably provided by means of a multiple, e.g. double, re-entrant bevel. In this way the abruptness of the resultant shoulder is diminished and the height in the hot top where residual mould flux remains after casting is increased. As already mentioned, the thickness of the slab enables the proportion of head metal to be decreased and the features just described help to maximise the proportion of the head metal that is usable.

The invention is further described with reference to the accompanying diagrammatic drawings in which:

Figure 1 is a vertical section through the upper part of an ingot mould having a hot top lining comprising slabs of the invention,

Figure 2 is a cross-section through the hot top lining at line I—I in Figure 1 and,

Figure 3 is a view of the recessed face of one of the slabs.

Referring to the drawings, the ingot mould has walls 1 tapering together upwardly to give an ingot narrower at the top than the bottom, and in the head of the mould is a hot top lining comprising four slurry-formed refractory, heat-insulating slabs 2 having a density of 0.5 g/cm³. The slabs 2 are suspended from the top of the mould by conventional means (not shown) and are held firmly in position by four wedges 3 of refractory, heat-insulating material.

Each of the slabs 2 has peripheral ribs 4, 5, 6, 7 at its outer face and these ribs together with two outwardly tapering inner ribs 8 define three recesses 9 in the outer face of the slab.

Whilst the invention has been described above with specific reference to the drawings, it is to be understood that the recesses 9 may be vertically

disposed in the outer face of slab 2. If desired, the eight-piece assembly illustrated in Figure 2 may be substituted by four, interengaging slabs or a six-piece assembly consisting of four slabs and two wedges.

Claims

1. A hot top lining slab (2) of refractory heat-insulating material having a plurality of ribs (4, 5, 6, 7, 8) at a face of the slab (2) defining a plurality of recesses (9) characterised in that the refractory heat-insulating material is slurry-formed, the slab (2) has a density in the range of 0.3 to 0.85 g/cm³ and an average overall thickness of at least 40 mm and the ribs (4, 5, 6, 7, 8) are at the back face of the slab (2) and define enclosed recesses (9) spaced inwardly from the periphery of the slab (2).

2. A hot top lining slab (2) according to claim 1 characterised in that the average overall thickness of the slab (2) is at least 50 mm.

3. A hot top lining slab (2) according to claim 1 or 2 characterised in that the ribs (4, 5, 6, 7, 8) provide at least 30% of the overall thickness of the slab (2).

4. A hot top lining slab (2) according to any preceding claim characterised in that the ribs (4, 5, 6, 7, 8) define at least three recesses (9).

5. A hot top lining slab (2) according to any preceding claim characterised in that the total area of the recesses (9) at the back face of the slab (2) is at least 30% of the total area of the back face of the slab (2).

6. A hot top lining slab (2) according to any preceding claim characterised in that at least one of the ribs (8) taper outwardly.

7. A hot top lining slab (2) according to claim 6 characterised in that the at least one tapered rib (8) is at least twice as wide at the base as at the tip.

8. A hot top lining slab (2) according to any preceding claim characterised in that the front face is bevelled at the edge which is to be lowermost in use.

9. A hot top lining slab (2) according to claim 8 characterised in that the bevel is a multiple, re-entrant bevel.

Patentansprüche

1. Warmhaubenverkleidungsplatte (2) aus feuerfestem wärmeisolierendem Material mit einer Mehrzahl von Rippen (4, 5, 6, 7, 8) auf einer Seite der Platte (2), die eine Mehrzahl Ausnehmungen (9) begrenzen, dadurch gekennzeichnet, dass das feuerfeste wärmeisolierende Material als Schlicker geformt wird, die Platte (2) eine Dichte im Bereich von 0,3 bis 0,85 g/cm³ sowie eine durchschnittliche Gesamtdicke von mindestens 40 mm aufweist und die Rippen (4, 5, 6, 7, 8) sich auf der Rückseite der Platte (2) befinden und eingeschlossene Ausnehmungen (9) begrenzen, die vom Umfang der Platte (2) her einwärts beabstandet sind.

2. Warmhaubenverkleidungsplatte (2) nach Anspruch 1, dadurch gekennzeichnet, dass die durchschnittliche Gesamtdicke der Platte (2) mindestens 50 mm beträgt.

3. Warmhaubenverkleidungsplatte (2) nach Anspruch 1 oder 2 dadurch gekennzeichnet, dass die Rippen (4, 5, 6, 7, 8) mindestens 30% der Gesamtdicke der Platte (2) ausmachen.

4. Warmhaubenverkleidungsplatte (2) nach einem der vorhergehenden Ansprüche, dadurch gekennzeichnet, dass die Rippen (4, 5, 6, 7, 8) mindestens drei Ausnehmungen (9) begrenzen.

5. Warmhaubenverkleidungsplatte (2) nach einem der vorhergehenden Ansprüche, dadurch gekennzeichnet, dass die Gesamtfläche der Ausnehmungen (9) auf der Rückseite der Platte (2) mindestens 30% von deren Gesamtfläche beträgt.

6. Warmhaubenverkleidungsplatte (2) nach einem der vorhergehenden Ansprüche, dadurch gekennzeichnet, dass mindestens eine der Rippen (8) sich nach aussen verjüngt.

7. Warmhaubenverkleidungsplatte (2) nach Anspruch 6, dadurch gekennzeichnet, dass die mindestens eine sich verjüngende Rippe (8) am Fuss mindestens doppelt so breit wie an der Spitze ist.

8. Warmhaubenverkleidungsplatte (2) nach einem der vorhergehenden Ansprüche, dadurch gekennzeichnet, dass die Vorderseite an der im Gebrauch zuunterst liegenden Kante abgeschrägt ist.

9. Warmhaubenverkleidungsplatte (2) nach Anspruch 8, dadurch gekennzeichnet, dass die Abschrägung mehrfach wieder einspringend ausgebildet ist.

Revendications

1. Une plaque (2) de garnissage de masselotte en matériau réfractaire thermo-isolant, dont une face présente une pluralité de nervures (4, 5, 6, 7, 8) définissant une pluralité d'évidements (9), caractérisée en ce que le matériau réfractaire thermoisolant est formé à partir de slurry, en ce

que la plaque (2) a une masse spécifique comprise dans la gamme de 0,3 à 0,85 g/cm³ et une épaisseur totale moyenne d'au moins 40 mm et en ce que les nervures (4, 5, 6, 7, 8) sont disposées sur la face arrière de la plaque (2) et définissent entre elles des évidements (9), situés à une certaine distance, vers l'intérieur, de la surface de la plaque (2).

2. Une plaque (2) de garnissage de masselotte suivant la revendication 1 caractérisée en ce que l'épaisseur totale moyenne de la plaque (2) est d'au moins 50 mm.

3. Une plaque (2) de garnissage de masselotte suivant la revendication 1 ou 2, caractérisée en ce que les nervures (4, 5, 6, 7, 8) interviennent pour au moins 30% de l'épaisseur totale de la plaque (2).

4. Une plaque (2) de garnissage de masselotte suivant l'une ou l'autre des revendications précédentes, caractérisée en ce que les nervures (4, 5, 6, 7, 8) définissent au moins trois évidements (9).

5. Une plaque (2) de garnissage de masselotte suivant l'une ou l'autre des revendications précédentes, caractérisée en ce que la surface totale des évidements (9) à la face arrière de la plaque (2) vaut au moins 30% de la superficie totale de la face arrière de la plaque (2).

6. Une plaque (2) de garnissage de masselotte suivant l'une ou l'autre des revendications précédentes, caractérisée en ce qu'au moins une des nervures (8) s'effile vers l'extérieur.

7. Une plaque (2) de garnissage de masselotte suivant la revendication 6, caractérisée en ce qu'au moins la nervure effilée (8) est au moins deux fois plus large à sa base qu'à son sommet.

8. Une plaque (2) de garnissage de masselotte suivant l'une ou l'autre des revendications précédentes, caractérisée en ce que la face frontale est chanfreinée à son arête qui, en service, est située au niveau le plus inférieur.

9. Une plaque (2) de garnissage de masselotte suivant la revendication 8, caractérisée en ce que le chanfrein est un chanfrein multiple rentrant.

5

10

15

20

25

30

35

40

45

50

55

60

65

4

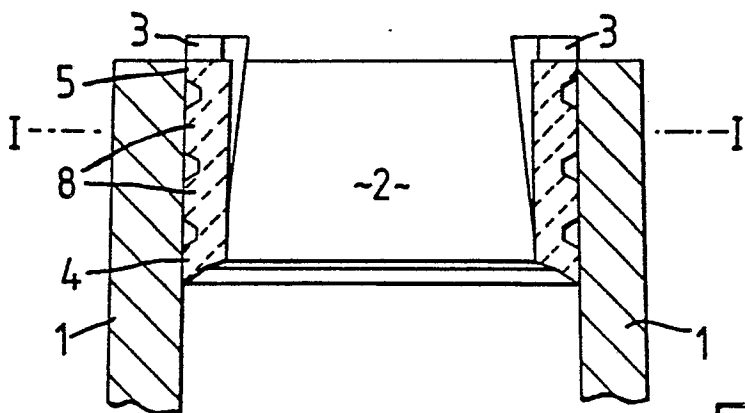

FIG. 1

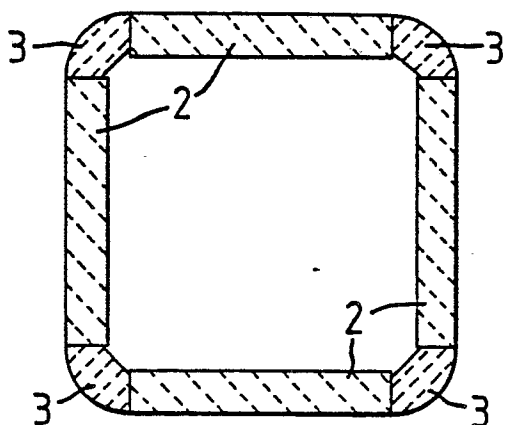

FIG. 2

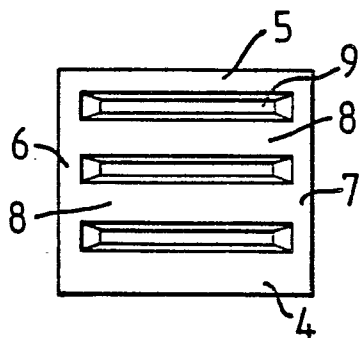

FIG. 3