

**EUROPEAN PATENT SPECIFICATION**

- ④ Date of publication of patent specification: **21.01.87**      ⑤ Int. Cl.<sup>4</sup>: **E 04 F 17/02**  
① Application number: **83303552.0**  
② Date of filing: **21.06.83**

④ **A prefabricated flue unit.**

③ Priority: **24.06.82 IE 1503/82**

④ Date of publication of application:  
**11.01.84 Bulletin 84/02**

④ Publication of the grant of the patent:  
**21.01.87 Bulletin 87/04**

④ Designated Contracting States:  
**AT BE CH DE FR GB IT LI LU NL SE**

⑤ References cited:  
**EP-A-0 038 211**  
**FR-A-1 004 443**  
**FR-A-1 443 047**  
**FR-A-1 601 559**  
**FR-A-2 173 373**

⑦ Proprietor: **Household Manufacturing Limited**  
**21 Holborn Viaduct**  
**London EC1 2DY (GB)**

⑦ Inventor: **Attwell, Ronald Leslie**  
**2 Horizon Brittans Bay**  
**Wicklow County Wicklow (GB)**

⑦ Representative: **Howden, Christopher Andrew**  
**FORRESTER & BOEHMART**  
**Widenmayerstrasse 4/1**  
**D-8000 München 22 (DE)**

Note: Within nine months from the publication of the mention of the grant of the European patent, any person may give notice to the European Patent Office of opposition to the European patent granted. Notice of opposition shall be filed in a written reasoned statement. It shall not be deemed to have been filed until the opposition fee has been paid. (Art. 99(1) European patent convention).

## Description

The invention relates to a prefabricated flue unit of the type comprising a casing having a through hole defining a flue, the unit being formed as a composite unit.

Examples of known flue units can be seen in EP—A—0038211 and FR—A—1601599.

One known unit of this type is of precast concrete material. Each unit is essentially a monolithic block having a through hole defining the flue. A plurality of cut-out channels extend axially from the bottom of the block to a position adjacent the top. The channels are closed off at the top end to provide a seat over which is laid a layer of mortar onto which is laid the next block with its closed end uppermost. The major disadvantage of such units is that as manufactured they do not satisfy the requirements of the appropriate building regulations and standards. In addition, because the material generally used is water permeable the outer faces must be rendered or a brick cladding provided around the assembled chimney. Further, a separate rendering or lining of the flue on site is also required to make it acid resistant.

In addition, the units, because of their weight are relatively difficult to handle. Further, the operation of building a chimney using these units is time consuming particularly due to the requirement of a mortar layer between each unit, the necessary cladding or rendering and in some cases the necessity for inserting a flue liner in each unit.

Thus, flues made from precast concrete units are generally heavy, inefficient and conform only to low level technical standards.

Other flue units prefabricated in sections from metal such as stainless steels or galvanised iron or clay are also known. Some of these units are provided with a cavity between a liner and casing to accept a loose infill of insulating material which is filled on site into the assembled chimney. These developments have improved the efficiency and technical standards of such chimneys however, they do not conform to current building regulations and standards particularly in respect of modern solid fuel appliances.

One object of this invention is to provide a prefabricated flue unit which will overcome these disadvantages and in particular will satisfy current building regulation requirements and comply with appropriate standards.

A prefabricated flue unit according to the invention is characterised in that the casing comprises an outer housing of a fibre reinforced cementitious material, the unit includes an inner liner of an acid and fire resistant material for the flue and an insulating fire resistant infill material interposed between the liner and the housing, a spacing member, having a cut-out portion for reception of the liner to retain the liner in position in the housing, is integrally moulded with the housing, means are provided for engaging one flue unit with another adjacent flue unit, the liner being formed with a male part at one end for engagement with a complementary female part at the

other end of a liner of an adjacent unit and the infill material being shaped to form a male or female part for interlocking with a complementary male or female part integral with the housing.

One particular advantage of the invention is it provides a relatively lightweight prefabricated unit from which a chimney which as manufactured will satisfy current building regulations and standards and can be quickly and easily constructed. The casing of fibre reinforced cementitious material not only gives a very lightweight unit but also because the material is dense the outer surfaces have low water permeability and generally do not require rendering or cladding. This, it will be appreciated considerably reduces the construction time over presently known units. In addition, the housing has a high load bearing structural strength and may be provided with decorative work on the outer faces.

The provision of the spacing member ensures that, particularly during manufacture of the unit, the liner is retained in a desired usually centrally located position in the housing. Because the spacing member is of the same material as that of the housing it may be cast in during manufacture and greatly assists in positively locating the liner in its desired position.

The means for engaging one unit with another flue unit facilitates the assembly of the units on site without the requirement of a layer of mortar between the units.

The housing may be substantially rectangular in cross-section having side walls, and the spacing member extends between the side walls, one end of the housing being recessed to define a socket part and the other end defining a spigot part for interlocking with a complementary socket part of another unit, the spigot and socket parts forming the interlocking means.

The advantage of the spigot and socket arrangement is that it assists in positively locating and interlocking one flue unit with another.

Typically the spacing member includes a tapered step portion defining together with the side walls the spigot part.

The advantage of this feature of the invention is that the step portion not only assists in the positive location of the spigot part in the socket part but also forms a water shed at the joint between adjacent units.

In another arrangement the spacing member is spaced-apart from one end of the housing to define together with the side walls at that end a socket part and the side walls adjacent the other end are formed with a tapered step portion to define the spigot part for interlocking with a socket part of an adjacent unit.

The advantage of this arrangement is that due to the positioning of the spacing member the positive location and interlocking of the units on site is ensured. The tapered step portion again provides a water shed at the joint.

Usually the housing and liner have the same vertical axis of symmetry.

In a particularly preferred embodiment of the

invention the thickness of the housing is between 4 and 15 mm, preferably between 5 and 8 mm.

Because the thickness of the housing is small, it is relatively lightweight.

In another embodiment of the invention the infill material is formed with a plurality of longitudinally extending voids to allow passage of air and condensates.

The advantage of this feature is that it provides a passageway through which air and condensate may pass through an assembled chimney.

The invention will be more clearly understood from the following description thereof given by way of example only with reference to the accompanying drawings in which:—

Fig. 1 is a perspective view of a prefabricated flue unit according to one embodiment of the invention,

Fig. 2 is a vertical sectional view through the unit of Fig. 1,

Fig. 3 is a plan view of the unit of Fig. 1,

Fig. 4 is a vertical sectional view of portion of a chimney or flue constructed from the flue units of Figs. 1 to 3 in one configuration,

Fig. 5 is a view similar to Fig. 3 of portion of a chimney with the flue units in another configuration,

Fig. 6 is a horizontal cross-sectional view of another construction of flue unit,

Fig. 7 is a perspective view of a further construction of flue unit,

Fig. 8 is a vertical sectional view of portion of a chimney or flue constructed from the flue units of Fig. 7,

Fig. 9 is a vertical cross-sectional view of another construction of flue unit,

Fig. 10 is an underneath perspective view of another flue unit, and

Fig. 11 is a top perspective view of the flue unit of Fig. 10.

Referring to the drawings and initially to Figs. 1 to 3 thereof, there is illustrated a prefabricated flue unit indicated generally by the reference numeral 1. The unit 1 comprises an outer housing 2, an inner liner 3 spaced-apart from the housing 2 to define therebetween a cavity which is filled with a lightweight fire-resistant insulating infill material 4. The unit 1 is prefabricated as a single lightweight composite unit a number of the units being interlocked one with another on site to build up a chimney or flue.

The housing 2 in this case is of rectangular box-shape having an open top 5, four depending side walls 6 and a base 7 communicating with the side walls 6 through a tapered step portion 8. Typical dimensions for the housing are 240 mm wide, 240 mm deep and 280 mm high. The housing 2 is moulded from a fibre-reinforced cementitious material, in this case, glass fibre reinforced cement (G.R.C.) to a wall thickness of between 4 and 15 mm and in most cases between 5 and 8 mm. The G.R.C. is sufficiently dense at these narrow thicknesses to provide the necessary load bearing strength and is substantially impervious to water so that rendering or cladding of a chimney con-

structed of a number of these units 1 is not required. In addition, because of the narrow wall thickness of the housing, the unit is relatively lightweight and can be easily handled by a single workman. It will further be appreciated that if desired, the housing could be formed with decorative work to give an aesthetically pleasing outer appearance to an assembled chimney or flue.

The base 7 of the housing 2 includes a central circular cut-out portion 9 for reception of the cylindrical liner 3. Essentially the base 7 provides a spacing member for retaining the liner 3 in position in the housing 2. The liner 3 is of any suitable fire and acid resistant material such as clay or metal such as stainless steel. It will be noted that the liner 3 and housing 2 in this case have the same vertical axis of symmetry.

The infill material 4 may be of any loose, granular, fibrous or a bound cohesive composite material with a density of between 350 kg per m<sup>3</sup> and 500 kg per m<sup>3</sup>. It may be, for example, a cementitious mixture of portland cement, expanded polystyrene beads and an insulating aggregate material such as perlite or vermiculite.

Both the top of the liner 3 and the insulating infill material 4 stop short of the open top 5 of the housing 2 to define a socket 15 having a depth h for reception of a complementary spigot 14 formed by the step portion 8 and base 7 of another flue unit 1. The step portion 8 extends for a distance d<sub>1</sub> which is equal to the depth h of the socket 15 so that when a spigot in one flue unit 1 is inserted in a complementary socket 15 in another the exposed rim of the liner 3 in one flue unit 1 will fit substantially flush with the exposed rim of the liner 2 in an adjacent flue unit 1 to form a substantially gas-tight joint. In addition, the step portions 8 act as lead-in guides for insertion of the spigot of one flue unit in the socket 15 of another unit so that on assembly the side walls 5 of adjacent units 1 are also substantially flush. The spigot and socket essentially form an interlocking means for engaging one flue unit with another.

Referring to Fig. 4 there is illustrated portion of a chimney flue 16 constructed from a plurality of the prefabricated composite units 1 just described. In this case the flue 16 is built up from a bottom support plinth 17 which is constructed with a complementary socket for reception of the base or spigot end 14 of one of the units 1. The next unit is then laid on top of the lowermost unit with its socket end 15 uppermost and the spigot end 14 engaging in the socket of the lower unit. Because of the tight fit of the spigot 14 in the socket 15 no mortar is required at the joint between adjacent units. The flue 16 is built up in this way by placing a number of units 1 one on top of another. Typically the units are built up to make a domestic chimney or flue to a height of between 8 and 12 metres.

It will be noted that in the assembled flue the step portion 8 on each spigot end 14 acts as a barrier or shed to prevent ingress of moisture through the joint between adjacent units.

Referring particularly to Fig. 5 there is illustrated another flue 20 constructed from a plurality of the units 1 described above with reference to Figs. 1 to 3. In this case, the units are turned so that their spigot ends 14 are uppermost. Again, the socket 15 of one unit is inserted in the spigot 14 of an adjacent unit to build up the flue 20. The particular advantage of this construction is that the step portion 8 forms a particularly effective moisture or water barrier to prevent ingress through the joint between adjacent units.

Referring particularly to Fig. 6 there is illustrated another construction of prefabricated flue unit according to the invention indicated generally by the reference numeral 30. The unit 30 is similar to that described above with reference to Figs. 1 to 3 and like parts are assigned the same reference numerals. In this case, three segment-shaped elongate longitudinal passageways 31 extend through the insulating material 4. Each passageway 31 is of arcuate shape in horizontal cross-section and is situated adjacent the outer periphery of the liner 3. The base 7 of the housing 2 is provided with slots (not shown) corresponding in shape to the passageways 31 to allow a continuous passageway to be built up through an assembled chimney or flue through which air and condensate may pass.

It will be appreciated that any convenient number, shape and configuration of such passageways may be provided through the insulating material to allow passage of air and condensation. Thus, it is not essential for the passageways to be provided around the periphery of the liner, they could, for example, be provided through the main body of the insulating material intermediate the liner and housing.

Referring to Fig. 7 there is illustrated an alternative prefabricated flue unit indicated generally by the reference numeral 40. The unit 40 is similar to that described above with reference to Figs. 1 to 3 and like parts are assigned the same reference numerals. In this case, the spacing member or base 7 of the housing 2 is spaced-apart from the bottom end of the housing to define together with the side walls 6 at that end a socket part 41. The side walls 6 adjacent the other end are formed with a straight step portion 42 to define a spigot part 43 for interlocking with a socket part 41 of an adjacent unit as may be seen particularly in Fig. 8. In this case, the liner 3 extends to a position flush with the free ends of the walls of the housing at both ends and the infill material 4 is filled up to the uppermost edge of the housing walls 6. The liner 3 is cut-away adjacent its top and bottom ends to form a female socket part 44 at the spigot end 43 of the housing and an oppositely directed complementary shaped male spigot part 45 at the socket end 41 of the housing 2.

On assembly, and referring particularly to Fig. 8 each flue unit 40 is positioned with its spigot end 43 uppermost, the socket end 41 of an adjacent unit being inserted over the spigot end 43 and the male and female parts 43, 44 of adjacent flue liners 3 interengaging to form a gas-tight joint.

Referring to Fig. 9 there is illustrated an alternative construction of flue unit 60 similar to that described above with reference to Fig. 8 and like parts are assigned the same reference numerals. In this case the means for interlocking one flue unit with another comprises a female socket part formed from a channel-shaped groove 61 extending around the periphery of the infill material 4 adjacent the top free end of the housing side wall 6 and a complementary shaped spigot wall 62 integral with and depending downwardly from the base 7 of the housing 2.

Referring to Figs. 10 and 11 there is illustrated another construction of composite flue unit 70 similar to that described above with reference to Figs. 1 to 3, like parts being assigned the same reference numerals. In this case, the uppermost end of the unit 70 is closed off by a top spacing plate 71 having a central circular cut-out portion 72 for the liner 3. Four triangular projections 73 are formed integral with and upstand from the plates 71 adjacent the corners thereof to form male spigot parts for interengagement in complementary shaped recesses 74 in the base member 7 of an adjacent unit 70. It will be noted that in this case the base 7 is cut-away leaving four angled strips 75 defining together with the side walls 6 of the housing 2 the recesses 74. The infill material 4 is extended to lie flush with the outer face of each strip 75 between the recesses 74.

The advantage of this particular construction of interlocking means is that the units are easily located one with another in use and form a particularly good joint which again does not require mortar.

The mixture used for the outer housing is preferably made by a high shear mixing process using a method and apparatus such as described in U.K. Patent Specification No. 1,553,196. This process and apparatus is particularly suitable for making casings from a fibre reinforced cementitious material such as G.R.C. and gives a high density product with narrow wall thickness that has relatively high structural strength. A typical density for the material is 2.2 tons/m<sup>3</sup> with a water vapour pressure of less than 1.3 metric perms. when measured according to BS3177 (1959). The material with this specification also passes the ISO impermeability test. It will be appreciated that the liner may also be formed of this material.

Usually the housing and liner are initially joined together and the insulating material filled into the cavity formed therebetween however, in some cases the inner liner is fitted as a separate unit after the insulation material has been cast or formed in the housing. In this case, the housing may be moulded from one or any number of parts cemented together and a mandrel inserted through the housing to form a void for reception of the liner while the cementitious infill material is poured in.

It will be appreciated that it is not essential to provide a base plate or indeed a plate at any location between the side wall of the housing for

5

10

15

20

25

30

35

40

45

50

55

60

65

4

retaining the liner in position since the infill material itself may provide the necessary spacing. The main advantage of having such a plate is that in fabricating the flue unit it prevents the infill material from flowing out of the housing. Thus, it will be appreciated that the plate may be removable and may be used only during the fabrication procedure. Alternatively, the plate may be formed integral with the liner. Indeed, the spacing member may be formed by a plurality of such plate members or cut away to any desired shape. It will be appreciated that in the case where the plate is reduced to provide only a locating lip the filler also locates the liner.

The liner and housing may be cemented together and the particular case where the infill material is cementitious based the infill itself may provide the necessary binding.

It will be appreciated that although a number of specific constructions of spigot and socket joints have been described for both the housing, liner and in some cases infill material, any suitable construction of interlocking means is within the scope of the invention. Thus, the housing liners or infill material may be a force or press fit one with another or may comprise any suitable shape and configuration of complementary interengageable or interlocking formations. The spigot and socket arrangements illustrated for the housing may equally be applied to the liners and infill material and vice versa.

In particular, it will be appreciated that the spigot or socket may be of any shape including rectangular, triangular or circular and may be straight sided or tapered as desired. Indeed, the spigot and socket part need not necessarily be formed in the same element of the unit thus, as in the case of the embodiment of Fig. 9 the housing may form a male or female part for interengagement with the complementary male or female part in the infill material and similarly the liner may, for example, be adapted to form a male or female part for interengagement with the male or female part of the liner, housing or infill material of an adjacent unit.

It will also be appreciated that although the housing has been described as box-shaped any appropriate shape such as cylindrical or hexagonal is envisaged. A cylindrical shaped unit is particularly envisaged since such a unit has the additional advantage that less material per unit length of section is required. Consequently, the unit will be lighter than box-shaped units without reducing the effect of insulation value of the infill material. Thus, the vertical sectional drawings illustrated would in the case of cylindrical units be taken across a diameter of the unit. It will further be appreciated that the side wall or walls of the unit may be tapered if required.

#### Claims

1. A prefabricated flue unit (1, 30, 40, 60, 70) of the type comprising a casing (2) having a through hole defining a flue, the unit being formed as a

composite unit, characterised in that the casing comprises an outer housing (2) of a fibre reinforced cementitious material, the unit includes an inner liner (3) of an acid and fire resistant material for the flue and an insulating fire resistant infill material (4) interposed between the liner (3) and the housing (2), a spacing member (7), having a cut-out portion (9) for reception of the liner (3) to retain the liner in position in the housing (2), is integrally moulded with the housing (2), means are provided for engaging one flue unit with another adjacent flue unit, the liner (3) being formed with a male part (45) at one end for engagement with a complementary female part (44) at the other end of a liner (3) of an adjacent unit and the infill material (4) being shaped to form a male or female part (73) for interlocking with a complementary male or female part (74) integral with the housing (2).

2. A flue unit as claimed in Claim 1, characterised in that the housing (2) is substantially rectangular in cross-section having side walls (6), and the spacing member (7) extends between the side walls (6), one end of the housing (2) being recessed to define a socket part (15, 41) and the other end defining a spigot (14, 43) part for interlocking with a complementary socket part (15, 41) of another unit, the spigot (14, 43) and socket parts (15, 41) forming the interlocking means.

3. A flue unit as claimed in Claim 2, characterised in that the spacing member (7) includes a tapered step portion (8) defining together with the side walls (6) the spigot part (14).

4. A flue unit as claimed in Claim 2, characterised in that the spacing member (7) is spaced apart from one end of the housing (2) to define together with the side walls (6) at that end a socket part (41, 61) and the side walls (6) adjacent the other end are formed with a straight step portion (42, 62) to define the spigot part (43, 62) for interlocking with a socket part (41, 61) of an adjacent unit.

5. A flue unit as claimed in any of Claims 1 to 4, characterised in that the housing (2) and liner (3) have the same vertical axis of symmetry.

6. A flue unit as claimed in any preceding claim characterised in that the thickness of the housing (2) is between 4 and 15 mm.

7. A flue unit as claimed in any preceding claim characterised in that the infill material (4) is formed with a plurality of longitudinally extending voids to allow passage of air and condensates.

#### Patentansprüche

1. Vorgefertigte Kaminleitungseinheit (1, 30, 40, 60, 70) einer Art, welche ein Gehäuse (2) aufweist, mit einer Durchgangsöffnung, welche eine Kaminleitung bildet, wobei die Einheit als zusammengesetzte Einheit ausgebildet ist, dadurch gekennzeichnet, daß das Gehäuse ein äußeres Gehäuse (2) aufweist aus einem faserverstärkten Zementmaterial, daß die Einheit ein inneres Einlegerohr (3) aufweist, aus einem säure-

und feuerbeständigem Werkstoff für die Kaminleitung, und ein isolierendes feuerbeständiges Einfüllmaterial (4), angeordnet zwischen dem Einlegerohr (3) und dem Gehäuse (2), ein Beabstandungselement (7), welches einen ausgeschnittenen Bereich (9) aufweist, zur Aufnahme des Einlegerohres (3), um das Einlegerohr in seiner Stellung in dem Gehäuse (2) zu halten, welches integral mit dem Gehäuse (2) ausgeformt ist, weiter dadurch, daß Elemente vorgesehen sind, um eine Kaminleitungseinheit mit einer anderen, angrenzenden Kaminleitungseinheit in Zusammenwirkung zu bringen, wobei das Einlegerohr (3) mit einem zapfenartigem Teil (45) ausgebildet ist, an einem Ende, zur Zusammenwirkung mit einem komplementären muffenartigen Teil (44) an dem anderen Ende des Einlegerohres (3) einer angrenzenden Einheit, und wobei das Einfüllmaterial (4) so geformt ist, daß es ein zapfenartiges oder muffenartiges Teil (73) bildet, zur Verriegelung mit einem komplementären zapfenartigem oder muffenartigem Teil (74), integral mit dem Gehäuse (2).

2. Kaminleitungseinheit nach Anspruch 1, dadurch gekennzeichnet, daß das Gehäuse (2) im wesentlichen im Querschnitt rechtwinklig ist, mit Seitenwänden (6), und daß das Beabstandungselement (7) sich zwischen den Seitenwänden (6), erstreckt, wobei ein Ende des Gehäuses (2) eine Aussparung aufweist, zur Bildung eines Muffenteils (15, 41), und das andere Ende einen Zapfenteil (14, 43) bildet, zur Verriegelung mit einem komplementären Muffenteil (15, 41) einer anderen Einheit, und wobei das Zapfenteil (14, 43) und das Muffenteil (15, 41) die Verriegelungselemente bildet.

3. Kaminleitungseinheit nach Anspruch 2, dadurch gekennzeichnet, daß das Beabstandungselement (7) einen verjüngenden Stufenbereich (8) aufweist, welcher zusammen mit den Seitenwänden (6) das Zapfenteil (14) bildet.

4. Kaminleitungseinheit nach Anspruch 2, dadurch gekennzeichnet, daß das Beabstandungselement (7) von einem Ende des Gehäuses (2) beabstandet ist, um zusammen mit den Seitenwänden (6) an diesem Ende einen Muffenteil (41, 61) zu bilden, und daß die Seitenwände (6) angrenzend dem anderen Ende mit einem geraden Stufenbereich (42, 62) ausgebildet sind, zur Bildung des Zapfenteils (43, 62) zur Verriegelung mit einem Muffenteil (41, 61) einer angrenzenden Einheit.

5. Kaminleitungseinheit nach einem der Ansprüche 1—4, dadurch gekennzeichnet, daß das Gehäuse (2) und das Einlegerohr (3) dieselbe vertikale Symetrieachse besitzen.

6. Kaminleitungseinheit nach einem der vorstehenden Ansprüche, dadurch gekennzeichnet, daß die Dicke des Gehäuses (2) zwischen 4 und 15 mm beträgt.

7. Kaminleitungseinheit nach einem der vorstehenden Ansprüche, dadurch gekennzeichnet, daß das Einfüllmaterial (4) mit einer Mehrzahl von sich längs erstreckenden Ausnehmungen

ausgebildet ist, um den Durchgang von Luft und Kondensat zu ermöglichen.

## Revendications

5

1. Élément de conduit de fumée préfabriqué (1, 30, 40, 60, 70) du type comprenant un boîtage (2) comportant un trou de passage définissant un conduit de fumée, l'élément étant constitué comme un élément composite, caractérisé en ce que le boîtage comprend une enveloppe extérieure (2) en matériau à base de ciment renforcé de fibres, en ce que l'élément comprend un revêtement intérieur (3) en matériau résistant à l'acide et au feu pour le conduit de fumée et un matériau de remplissage (4) isolant et ignifuge interposé entre le revêtement (3) et l'enveloppe (2), en ce qu'un élément d'écartement (7), comportant une partie découpée (9) pour recevoir le revêtement (3) afin de maintenir le revêtement en position dans l'enveloppe (2), est moulé d'une seule pièce avec l'enveloppe, en ce que des moyens sont prévus pour interengager un élément de conduit de fumée avec un autre élément de conduit de fumée adjacent, le revêtement (3) comportant à une extrémité une partie mâle (45) destinée à s'engager dans une partie femelle complémentaire (44) à l'autre extrémité du revêtement (3) d'un élément adjacent, tandis que le matériau de remplissage (4) est conformé de façon à constituer une partie mâle ou femelle (73) pour interengagement avec une partie complémentaire mâle ou femelle (74) faisant partie intégrante de l'enveloppe (2).

10

15

20

25

30

35

40

45

50

55

60

65

2. Élément de conduit de fumée selon la revendication 1, caractérisé en ce que l'enveloppe (2) est de section transversale sensiblement rectangulaire et comporte des parois latérales (6), et en ce que l'élément d'écartement (7) s'étend entre les parois latérales (6), en ce qu'une extrémité de l'enveloppe (2) est évidée pour définir une partie manchon (15, 41) et l'autre extrémité définit une partie bossage (14, 53) pour interengagement avec une partie manchon complémentaire (15, 41) d'un autre élément, les parties bossage (14, 43) et manchon (15, 41) constituant les moyens d'interengagement.

3. Élément de conduit de fumée selon la revendication 2, caractérisé en ce que l'élément d'écartement (7) comprend une partie en gradin présentant une dépouille (8), cette partie définissant avec les parois latérales (6) la partie bossage (14).

4. Élément de conduit de fumée selon la revendication 2, caractérisé en ce que l'élément d'écartement (7) est espacé d'une extrémité de l'enveloppe (2) pour définir à cette extrémité avec les parois latérales (6) une partie manchon (41, 61), et en ce que, à l'autre extrémité, les parois latérales (6) comprennent une partie en gradin droit (42, 62) pour définir la partie bossage (43, 62) destinée à l'interengagement avec une partie manchon (41, 61) d'un élément adjacent.

5. Élément de conduit de fumée selon l'une

quelconque des revendications 1 à 4, caractérisé en ce que l'enveloppe (2) et le revêtement (3) ont le même axe de symétrie vertical.

6. Elément de conduit de fumée selon l'une quelconque des revendications précédentes, caractérisé en ce que l'épaisseur de l'enveloppe (2) est comprise entre 4 et 15 mm.

7. Elément de conduit de fumée selon l'une quelconque des revendications précédentes, caractérisé en ce que le matériau de remplissage (4) comporte plusieurs vides s'étendant longitudinalement pour permettre le passage d'air et de condensats.

10

15

20

25

30

35

40

45

50

55

60

65

7

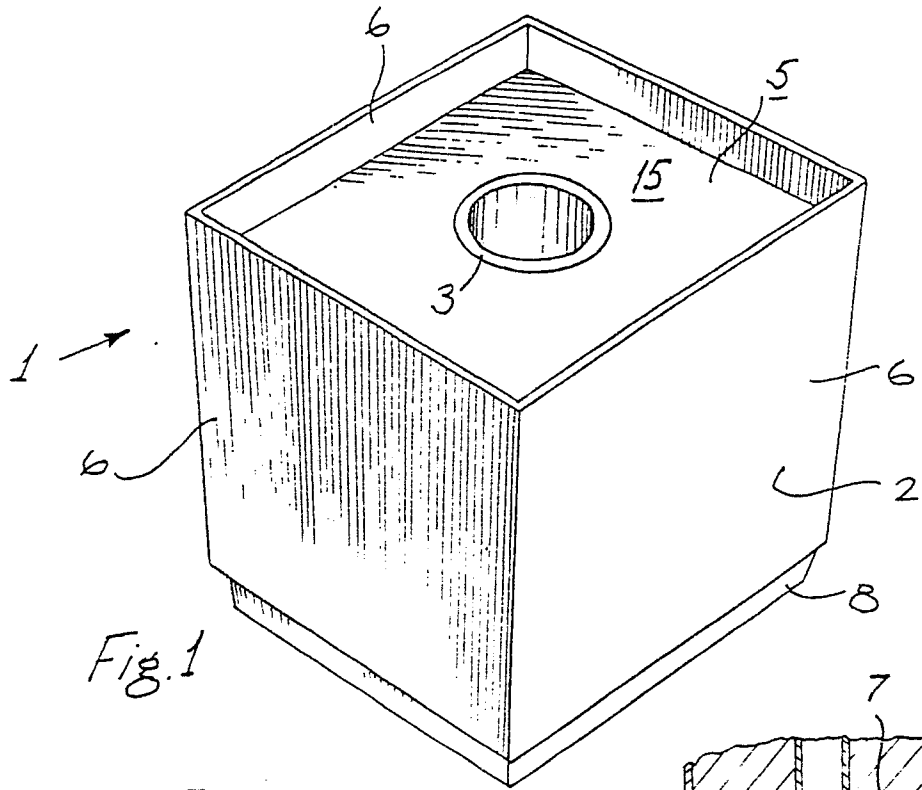

Fig. 1

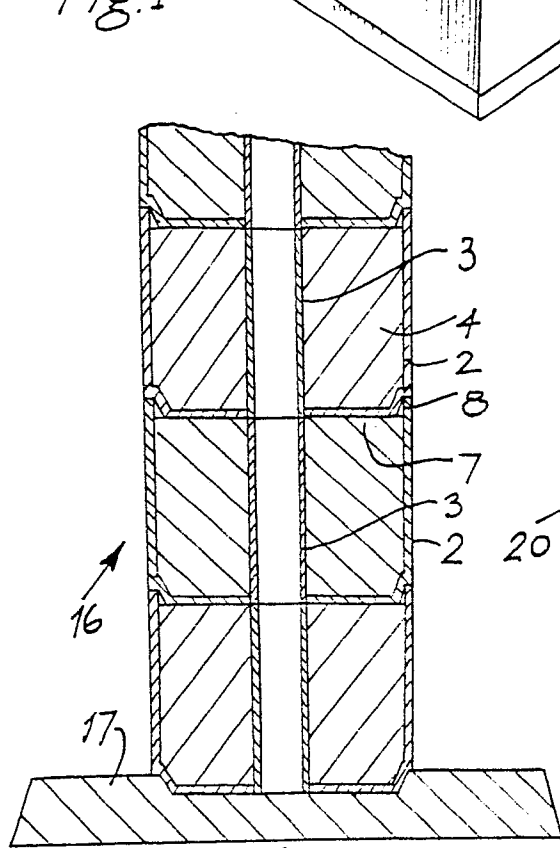

Fig. 4

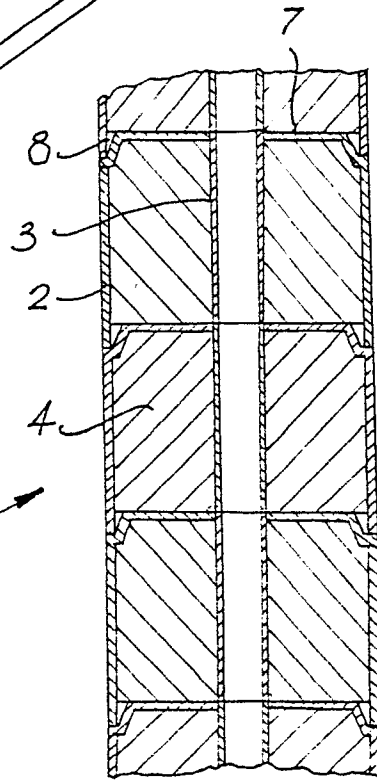
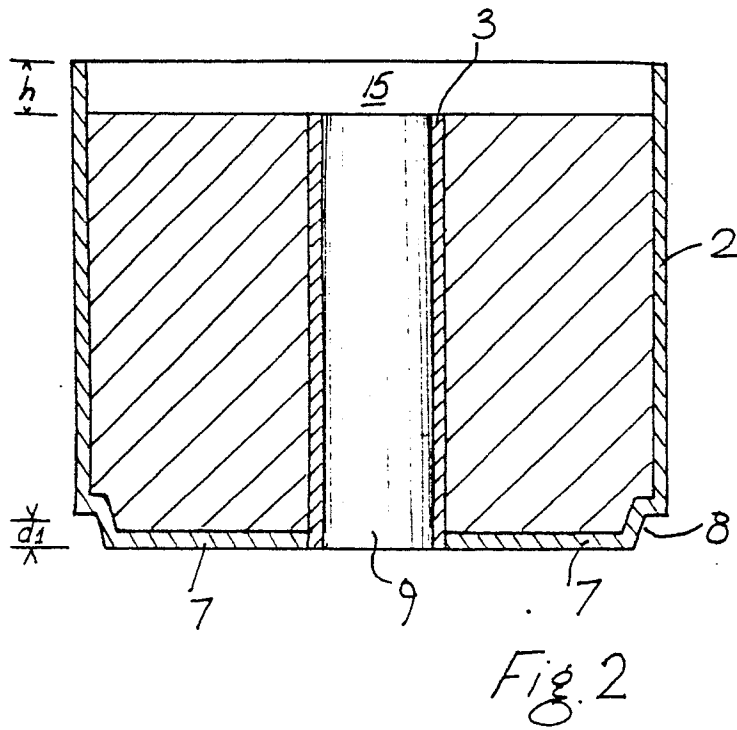
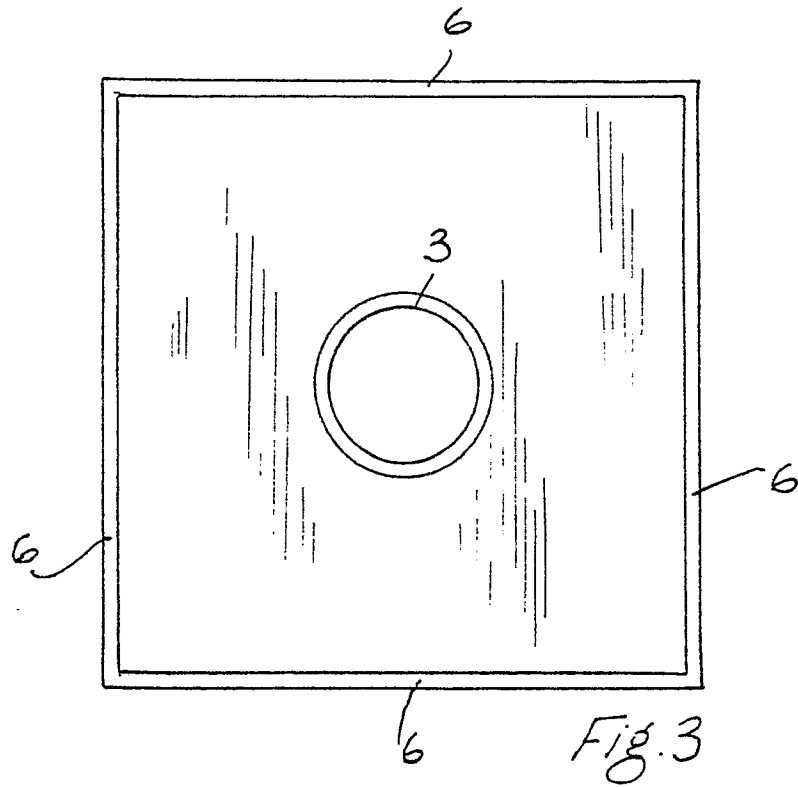

Fig. 5



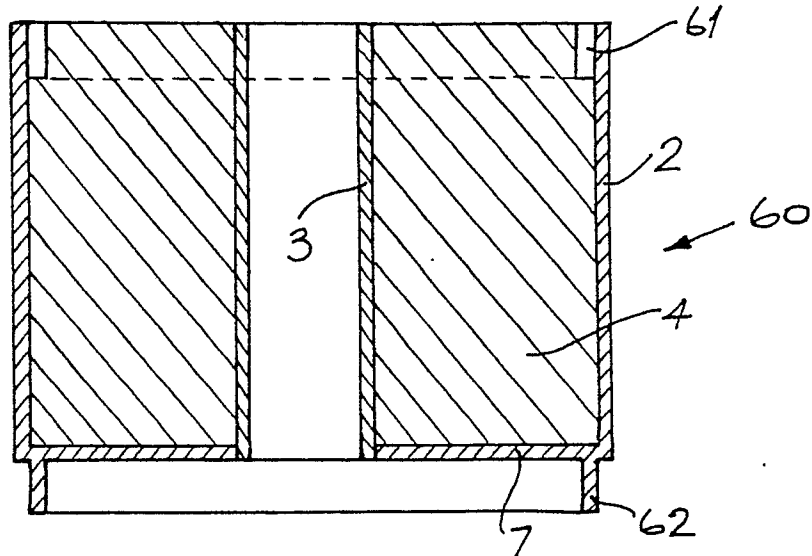

Fig. 9

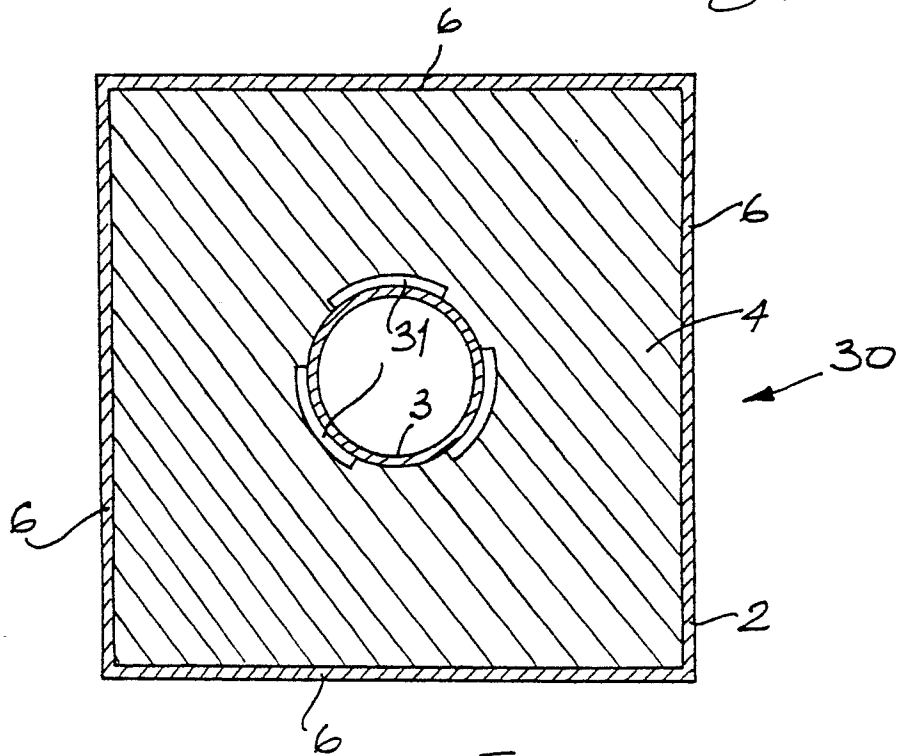

Fig. 6

