



 **EUROPEAN PATENT APPLICATION**

 Application number: 83200998.9

 Int. Cl.<sup>3</sup>: **A 47 K 10/34**

 Date of filing: 05.07.83

 Priority: 06.07.82 NL 8202708

 Date of publication of application:  
 01.02.84 Bulletin 84/5

 Designated Contracting States:  
 BE CH DE FR GB LI NL

 Applicant: **Brabantia Leasing & Factoring AG**  
 Hodlerstrasse 233  
 Härkingen(CH)

 Inventor: **Brinkmann, Valentinus Johannes**  
 Maarten Trompstraat 17  
 NL-5582 JN Waalre(NL)

 Representative: **de Vries, Johannes Hendrik**  
 Fokke et al,  
 Octrooibureau Los en Stigter B.V. P.O. Box 20052  
 NL-1000 HB Amsterdam(NL)

 **Apparatus for dispensing a flexible web material.**

 An apparatus (1) for dispensing a flexible web material comprises a closed cabinet (2) with dispensing opening (3) for the web, and supporting means (6, 9-14) mounted in the cabinet for rotatable support of two rolls (7, 8) of the web material, the web (15) of the first roll (7) being guided out of the cabinet (2) along a plurality of guide rollers (25, 28) and through the dispensing opening (3) and the leading end (17) of the web (16) of the second roll (8) lying ready in a reserve position within the cabinet (2), whereas means (18) are provided for feeding said leading end of the second web through the dispensing opening (3) out of the cabinet (2) by means of the remainder of the first web. Said means (18) include a pressure roller (10) and a supporting roller (20) which are mounted in the cabinet (2), the first web (15) and the leading end (17) of the second web (16) being led between the pressure roller (19) and the supporting roller (20). The pressure roller (19) is pivotable by means of the first web (15) between a working position in which the pressure roller (10) presses both webs (15, 16) on the supporting roller (20) and a rest position in which the pressure roller (19) is spaced from the supporting roller (20) in such a manner that the pressure roller (19) is each time pivoted into the rest position when a piece of the first web (15) is delivered so that the leading end (17) of the second web (16) remains in the reserve position, whereas, as soon as the trailing end of the

first web (15) leaves the first roll (7), the pressure roller (19) is retained in the working position and the leading end (17) of the second web (16) is fed out of the cabinet (2) through the dispensing opening (3) by drawing out the last piece of the first web (15).

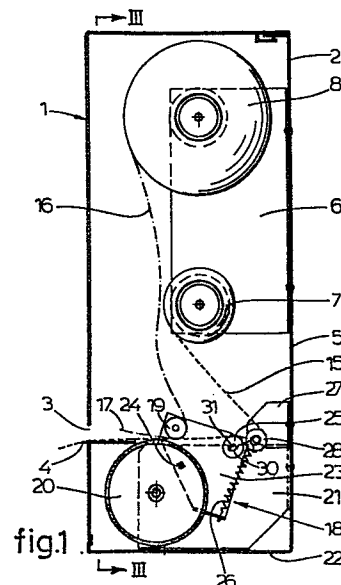

Apparatus for dispensing a flexible web material.

The invention relates to an apparatus for dispensing a flexible web material, comprising a closed cabinet with dispensing opening for the web, and supporting means mounted in the cabinet for rotatable support of two rolls of the web material, the web of the first roll being guided  
5 out of the cabinet along a plurality of guide rollers and through the dispensing opening and the leading end of the web of the second roll lying ready in a reserve position within the cabinet, whereas means are provided for feeding  
10 said leading end of the second web through the dispensing opening out of the cabinet by means of the remainder of the first web.

A known apparatus of this type, for instance a roll paper towel dispenser, is provided with a relatively complicated construction for guiding the leading end of the web  
15 of the second roll out of the cabinet, as the first roll runs out. Furthermore this construction is such, that the leading end of the web of the second roll is already fed from the cabinet, when still some of the web of the first roll is present, so that material of both rolls is simultaneously  
20 delivered during some time. This is an undesired aspect of the prior art apparatus.

The invention aims to provide an apparatus as indicated above, in which said objections have been eliminated or diminished in a simple but nevertheless efficient manner.  
25 To this end the apparatus according to the invention is characterized, in that said means include a pressure roller and a supporting roller which are mounted in the cabinet, the first web and the leading end of the second web being led between the pressure roller and the supporting  
30 roller, said pressure roller being pivotable by means of the first web between a working position in which the pressure roller presses both webs on the supporting roller and a rest position in which the pressure roller is spaced from the supporting roller in such a manner that the pressure roller is each  
35 time pivoted into the rest position when a piece of the first web is delivered so that the leading end of the second web remains in the reserve position, whereas, as soon as the



0099602

trailing end of the first web leaves the first roll, the pressure roller is retained in the working position and the leading end of the second web is fed out of the cabinet through the dispensing opening by drawing out the last piece  
5 of the first web.

A very simple construction for delivering the leading end of the second web from the cabinet is achieved in this manner, whereas the leading end of the second web is only fed from the reserve position out of the cabinet, when the  
10 last piece of the first web is delivered.

According to the invention the pressure roller and a first guide roller for the first web are both borne at their ends in common supports which are rotatably mounted in the cabinet, the pressure roller and the guide roller being  
15 located on either side of a vertical plane containing the rotation axes of the supports, whereas a second guide roller for the first web is borne in fixed brackets and lies below a plane contacting the upper side of the first guide roller and the lower side of the pressure roller, the first web  
20 extending from the first roll of web material underneath the second guide roller and over the first guide roller to the pressure roller and the supporting roller. By means of a particularly simple and robust construction the pressure roller is automatically pivoted hereby from the working  
25 position to the rest position by the deliverance of a piece of the first web as long as the first roll carries still any quantity of material.

Hereafter the invention is further illustrated by means of the accompanying drawing, wherein an embodiment of  
30 the apparatus according to the invention is represented.

Fig. 1 is a schematic representation in cross-section of an embodiment of the apparatus according to the invention, wherein the first roll still carries a certain amount of web material and the pressure roller is in the  
35 rest position.

Fig. 2 is a cross-section corresponding to fig. 1, wherein the first roll of web material is empty and the pressure roller is in the working position.

Fig. 3 is a section according to line III-III of  
40 fig. 1.

0099602

Fig. 1 shows a section of an apparatus 1 for dispensing a flexible web material, such as for example paper towelling, which apparatus 1 comprises a closed cabinet 2 with dispense opening 3. Near the dispense opening 3 a cutting or tearing device 4 is located for tearing of a piece of the web delivered through the dispense opening 3. The cabinet 2 may through its back wall 5 be fixed to a wall.

As appears from the section of fig. 3 two support plates 6 are mounted on the back wall 5, said support plates 6 rotatably supporting two feed rolls 7, 8 of web material. To this end the support plates 6 are provided with roll holders 9 and 10 which extend into the core 11 of the feed rolls 7, 8. The roll holders 9 are connected in fixed relationship with the corresponding support plate 6 by means of a stud 12, whereas the roll holders 10 are connected in a rotatable relationship with the corresponding support plate 6 by means of an axis 13. For replacement of a feed roll the roll holders 10 may be pushed against the action of a spring 14 in the direction of a support plate 6. It is also achieved by means of the springs 14, that the feed rolls 7, 8 are friction rotatable, so that no unduly large pieces of the web material are delivered.

The web 15 of the first feed roll 7 is guided through the dispense opening 3 out of the cabinet 2, whereas the web 16 of the second feed roll 8, which serves as reserve roll, is entirely located within the cabinet 2, whereas the leading end 17 lies ready in a reserve position.

Under both feed rolls 7, 8 a mechanism 18 is located, which may transport the leading end 17 of the second web 16 through the dispense opening 3 out of the cabinet 2 by means of the remainder of the first web 15.

The mechanism 18 comprises a pressure roller 19 and a supporting roller 20 with substantially larger diameter. The supporting roller 20 is rotatably borne at its outer ends in support plates 21, which are connected with both the bottom 22 and the back wall 5 of the cabinet 2. The pressure roller 19 is borne at its outer ends in carrying plates 23 which are rotatably connected with the support plates 21 by means of an axis 24. The carrying plates 23 also support a first guide roller 25 for the first web 15. The pressure roller 19 and the first

0099602

guide roller 25 are located on either side of a virtually vertical plane containing the axes 24 of the carrying plates 23. By pivoting the carrying plates 23 around the axes 24 the pressure roller 19 may be pivoted from a working position represented in fig. 2 into a rest position represented in 5 fig. 1, as will still be further illustrated hereinafter. The carrying plates 23 each are retained in the position corresponding to the working position of the pressure roller 19 by means of a spring 26.

10 Two fixed supports 27 are mounted to the back wall 5 of the cabinet 2, which supports carry a second guide roller 28. The second guide roller 28 is located under a plane contacting the lower side of the pressure roller 19 and the upper side of the first guide roller 25 when the pressure 15 roller 19 is in the working position.

The first web 15 extends from the first feed roll 7 underneath the second guide roller 28, over the first guide roller 25 to the pressure roller 19 and the supporting roller 20. Between these rollers 19, 20 the web 15 extends out of 20 the cabinet 2. The second web 16 is only guided between the pressure roller 19 and the supporting roller 20, whereas the leading end 17 lies ready in the reserve position within the cabinet 2, as indicated in fig. 1. If then a piece of the first web 15 is withdrawn from the cabinet 2, a force directed 25 opposite to the action of the spring 26 is exerted on the first guide roller by the web 15, which force is larger than the force exerted by the springs 26 because of the relatively large friction which should be surpassed for rotation of the feed roll 7. The pressure roller 19 will be pivoted hereby 30 from the working position represented in fig. 2, in which the pressure roller 19 presses both webs 15, 16 onto the supporting roller 20 to the rest position of fig. 1, in which the pressure roller 19 is in spaced relationship to the supporting roller 20, so that the web 15 will slip along the 35 web 16 and the leading end 17 of the web 16 will remain in the reserve position. However, as soon as the trailing end 29 leaves the feed roll 7, as indicated in fig. 2, the springs 26 will retain the pressure roller in working position, so that at deliverance of the last piece of the web 15 the 40 web 16 will be entrained by the friction arising between

0099602

both webs 15, 16 and the leading end 17 will be fed outside the cabinet 2 as represented in fig. 2.

5 In this manner it is achieved, that only together with the last piece of the web 15 a double amount of the flexible web material will be delivered.

As it appears from fig. 1-3 each of the support plates 21 constitutes a stop 30 for the axis 31 of the guide roller 25. The stops 30 restrict the pivotation of the carrying plates 23.

10 It is remarked that the supporting roller 20 is provided with rough surface areas 32, so that the supporting roller 20 will undergo rotation during deliverance of a piece of the web.

15 As appears from the above hardly any double amount of the web material is delivered by the present apparatus 1. If it appears at inspection that the feed roll 7 is empty, the feed roll 8 may be placed on the lower roll holders 9, 10 and a new feed roll may be placed on the upper roll holders 9, 10. Therefore each feed roll may fully be used.

20 The invention is not restricted to the herein described embodiment, which may be varied in different manners within the scope of the invention.



Claims

1. Apparatus for dispensing a flexible web material, comprising a closed cabinet with dispensing opening for the web, and supporting means mounted in the cabinet for rotatable support of two rolls of the web material, the web of the first roll being guided out of the cabinet along a plurality of guide rollers and through the dispensing opening and the leading end of the web of the second roll lying ready in a reserve position within the cabinet, whereas means are provided for feeding said leading end of the second web through the dispensing opening out of the cabinet by means of the remainder of the first web, characterized in that said means include a pressure roller and a supporting roller which are mounted in the cabinet, the first web and the leading end of the second web being led between the pressure roller and the supporting roller, said pressure roller being pivotable by means of the first web between a working position in which the pressure roller presses both webs on the supporting roller and a rest position in which the pressure roller is spaced from the supporting roller in such a manner that the pressure roller is each time pivoted into the rest position when a piece of the first web is delivered so that the leading end of the second web remains in the reserve position, whereas, as soon as the trailing end of the first web leaves the first roll, the pressure roller is retained in the working position and the leading end of the second web is fed out of the cabinet through the dispensing opening by drawing out the last piece of the first web.

2. Apparatus according to claim 1, characterized in that the pressure roller and a first guide rollers for the first web are both borne at their outer ends in common supports which are rotatably mounted in the cabinet, the pressure roller and the guide roller being located on either side of a vertical plane containing the rotation axes of the supports, whereas a second guide roller for the first web is borne in fixed brackets and lies below a plane contacting the upper side of the first guide roller and the lower side of the pressure roller, whilst the first web extends from the first roll of web material underneath the second guide roller and over the first guide roller to the pressure roller and the supporting

0099602

roller.

3. Apparatus according to claims 2, characterized  
in that the supports each are retained in a position cor-  
responding to the working position of the pressure roller by  
5 means of a spring, and in that the first roll of web material  
is friction rotatable, whereas the force exerted by this web on  
the first guide roller during deliverance of a piece of the  
first web is larger than the oppositely directed force exer-  
ted by the springs.

10 4. Apparatus according to claim 2 or 3, characteri-  
zed in that a stop is provided restricting the pivotation of  
the supports.

5. Apparatus according to claim 4, characterized  
in that the supporting roller is at both sides borne in a  
15 support plate, whereas each of the supports is connected in  
a rotatable relationship with a support plate and the  
support plates serve as stops for the supports.

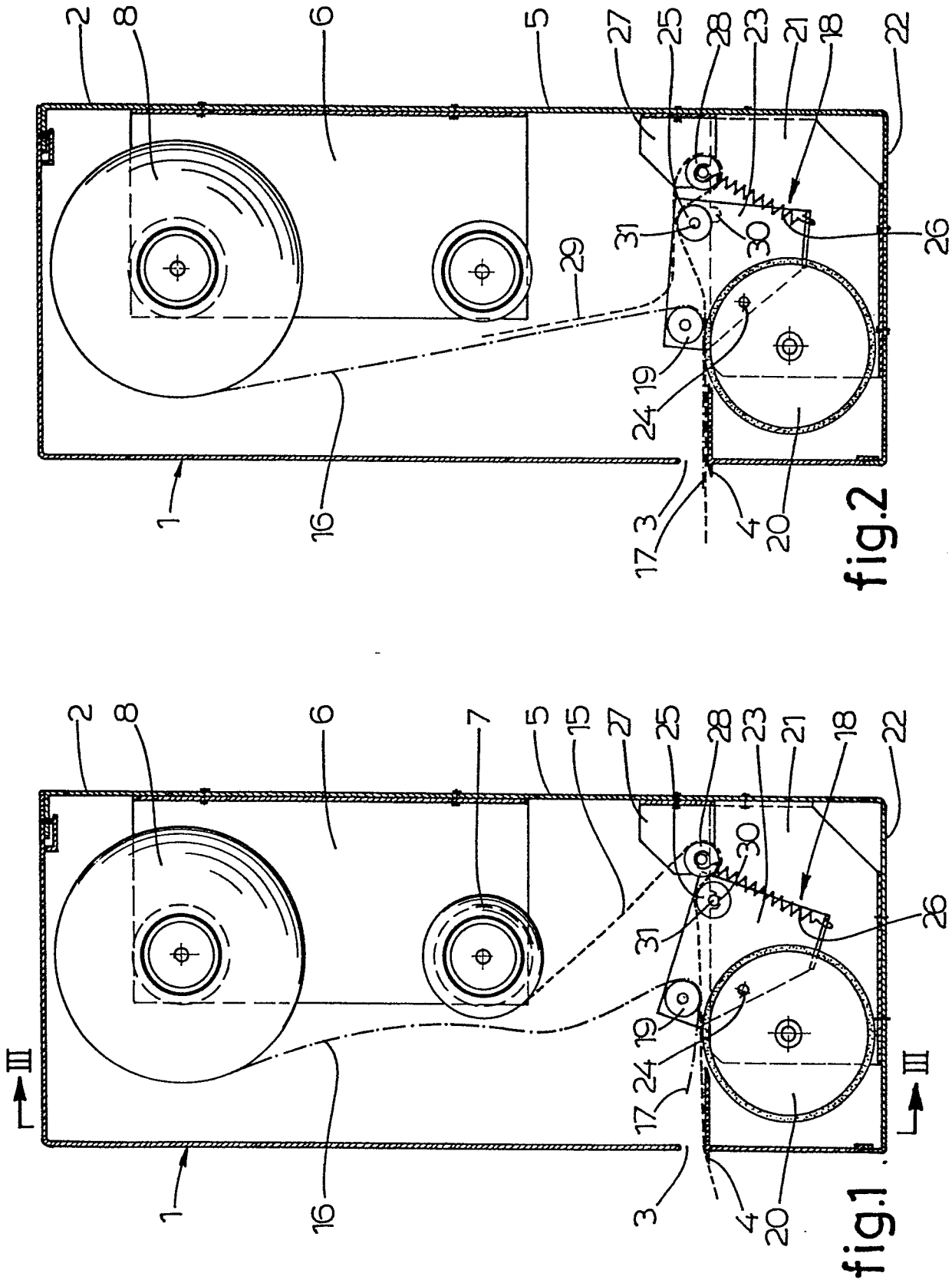

fig.2

fig.1

2/2

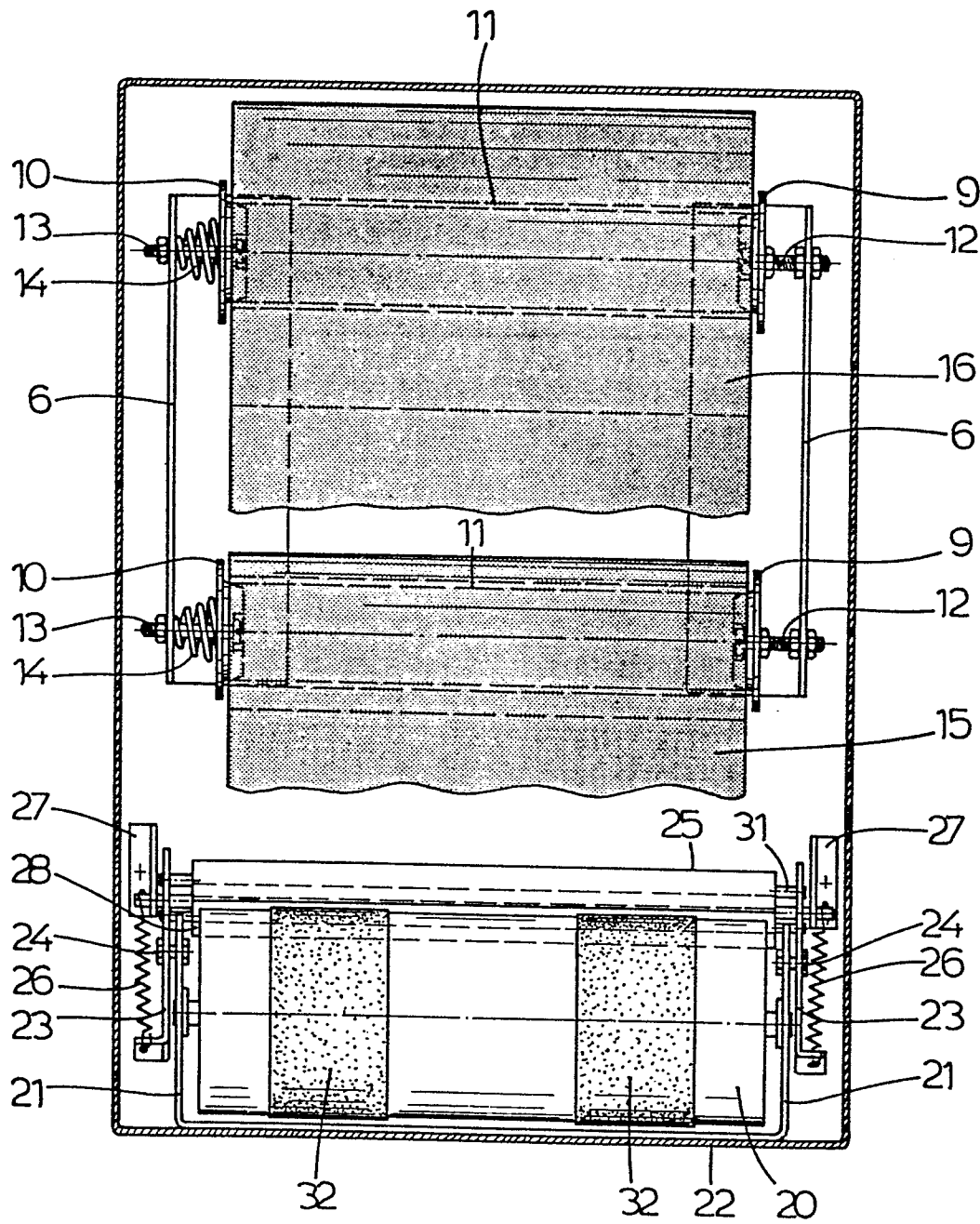

fig.3



European Patent  
Office

EUROPEAN SEARCH REPORT

0099602

Application number

EP 83 20 0998

DOCUMENTS CONSIDERED TO BE RELEVANT			
Category	Citation of document with indication, where appropriate, of relevant passages	Relevant to claim	CLASSIFICATION OF THE APPLICATION (Int. Cl. <sup>3</sup> )
X	US-A-4 010 909 (BASTIAN) * Column 5, line 65 - column 6, line 8; figure 3 *	1-3	A 47 K 10/34
X	US-A-3 917 191 (GRAHAM) * Whole document *	1-5	
X	US-A-4 317 547 (GRAHAM) * Whole document *	1-3	
X	FR-A-2 387 627 (APURA) * Whole document *	1-3	
			TECHNICAL FIELDS SEARCHED (Int. Cl. <sup>3</sup> )
			A 47 K
The present search report has been drawn up for all claims			
Place of search THE HAGUE		Date of completion of the search 06-10-1983	Examiner MEULEMANS J.P.
<p>CATEGORY OF CITED DOCUMENTS</p> <p>X : particularly relevant if taken alone  Y : particularly relevant if combined with another document of the same category  A : technological background  O : non-written disclosure  P : intermediate document</p> <p>T : theory or principle underlying the invention  E : earlier patent document, but published on, or after the filing date  D : document cited in the application  L : document cited for other reasons</p> <p>&amp; : member of the same patent family, corresponding document</p>			