

⑫ **EUROPEAN PATENT SPECIFICATION**

- ④⑤ Date of publication of patent specification: **13.01.88** ⑤① Int. Cl.⁴: **F 04 F 10/00**
②① Application number: **83901774.6**
②② Date of filing: **15.04.83**
⑧⑧ International application number:
PCT/US83/00564
⑧⑦ International publication number:
WO 83/03642 27.10.83 Gazette 83/25

⑤④ **FUEL TRANSFER IN FUEL TANKS.**

- | | |
|---|--|
| <p>③⑧ Priority: 16.04.82 US 369304</p> <p>④③ Date of publication of application:
18.04.84 Bulletin 84/16</p> <p>④⑤ Publication of the grant of the patent:
13.01.88 Bulletin 88/02</p> <p>⑧④ Designated Contracting States:
DE FR GB</p> <p>⑤⑥ References cited:
DE-A-2 440 905
DE-C- 282 209
DE-C- 807 206
GB-A- 528 415
US-A-2 530 819
US-A-3 006 358
US-A-3 021 855
US-A-3 083 720</p> | <p>⑦③ Proprietor: BOWLES FLUIDICS CORPORATION
6625 Dobbin Road
Columbia Maryland 21045 (US)</p> <p>⑦② Inventor: STOUFFER, Ronald D.
14120 Ansted Road
Silver Spring, MD 20902 (US)</p> <p>⑦④ Representative: Hayward, Denis Edward Peter
et al
Lloyd Wise, Tregear & Co. Norman House
105-109 Strand
London WC2R 0AE (GB)</p> |
|---|--|

Note: Within nine months from the publication of the mention of the grant of the European patent, any person may give notice to the European Patent Office of opposition to the European patent granted. Notice of opposition shall be filed in a written reasoned statement. It shall not be deemed to have been filed until the opposition fee has been paid. (Art. 99(1) European patent convention).

Description

The present invention relates to liquid transfer by means of siphons and vortex devices, and particularly to a method of and apparatus for transferring liquid from one compartment to another compartment of a sealed container such as a fuel tank utilizing the partial vacuum created in the output passage of the vortex device as the siphon initiating force.

With the development in recent years of very small compact vehicles, problems have arisen as a result of reduction in available space for various elements of the vehicle. In a recent design of a motor vehicle, a vertical indentation must be provided in the bottom surface of the fuel tank to accommodate the car's tail pipe while maintaining the fuel tank in an acceptable position both with respect to the ground and the rear of the vehicle. The problem with such an arrangement is that the vertical indentation in the bottom of the tank presents an obstacle to the free flow of liquid from at least one of the compartments formed by the obstacle.

In a particular vehicle which uses a throttle body injector, a turbine pump is located in the fuel tank for pumping fluid to the injector. The pump can withdraw liquid from only one side of the vertical obstacle; being a sump-type pump it does not have sufficient negative pressure to draw liquid over the obstacle. The sump pump is preferred because of its high efficiency. In such a system, it is critical that no material reduction in pressure be encountered in the flow from the pump to the throttle body injector thus prohibiting the use of venturis. Further, the system cannot tolerate the diversion of an appreciable quantity of liquid being pumped to the injector. A further constraint on the system is that moving parts such as ball valves, spring biased valves, etc., cannot be tolerated in such an environment. Hitherto, a suitable solution had not been found to this problem.

It is well known, of course, that liquid can be transferred from one place to another, if the liquid levels in the two places are different, by means of a siphon. One such arrangement is shown in DE—C—282209. Such a siphon has indeed also been proposed for the compartments of vehicle fuel tanks, as in US—A—3021855. In that U.S. Patent, the inventors provided a siphon pipe extending between the two compartments of a fuel tank and relied on surges of fuel due to the motions of the vehicle to set the siphon into operation, there being a check valve to ensure that flow could proceed only one way into the tank containing the fuel pump. However, in practice one cannot rely on fuel surges to operate such a siphon and the system is quite inadequate.

In another prior Patent, DE—A—2440905, the fuel is pumped through a transfer pipe from one compartment to the other by means of a venturi driven by liquid fuel diverted from the output of the main fuel pump supplying the vehicle engine. However, that scheme requires a large compara-

tively expensive main pump with the capacity to provide not only the output to the engine but also the considerable amount of flow needed for diversion to drive the venturi; and in the prior patent referred to the pump was located outside the fuel tank. The problem in the present instance is how to find a solution when the fuel sump is a sump pump inside the tank generating virtually no negative pressure at its inlet and of which the output capacity is such that diversion of the amount needed to drive a venturi cannot be tolerated.

According to the present invention there is provided an apparatus for pumping liquid from a compartmentalized container, comprising a container having at least two compartments, an obstacle separating said compartments, a transfer conduit extending between said compartments over said obstacle, and a pump for pumping liquid out of said container through an outlet and for ingesting liquid into said pump through an inlet at a low negative pressure with said inlet communicating with one of said compartments, characterised by a vortex amplifier responsive to flow of liquid from the outlet of said pump for developing a negative pressure which is applied to said transfer conduit and is sufficient to lift liquid in at least one of said compartments to the maximum height of said conduit.

In accordance with one embodiment of the invention, the vortex device which is driven by the sump pump is utilized to create a sufficient suction in the transfer conduit to raise the level of liquid therein over the obstacle and initiate a siphoning action between the compartment remote from the pump and the compartment in which the pump is located. The vortex device may be located in series with the flow of fluid from the pump to the throttle body injector or may be in effect a shunt to sump that is, may tap off a small amount of liquid from the conduit leading to the throttle body injector internally of the fuel tank and return the small amount of diverted fluid to the tank.

In a situation where the vortex device is in series with the flow from the pump to the conduit, a vortex amplifier having a relatively small pressure drop is utilized, the pressure drop being controlled by the relative radii of the main vortex device chamber and the outlet passage. In a system where the vortex device constitutes a shunt to sump, the ratio of the radius of the vortex chamber to the radius of the outlet passage is made quite large so that a very high impedance to flow is developed and relatively little fluid is diverted from the main flow.

The theory underlying vortex amplifiers may be found in U.S. Patents as follows: 3,276,259; 3,320,815; 3,413,995; 3,410,143; 3,504,688 and the like.

The specific problem which the present invention must solve arises when one understands that the pump which is preferred in the particular environment with which the present invention is dealing is a sump pump, or specifically, a pump

that is within the body of liquid and uses blades or other means to move the liquid in which it is immersed up into the outflow pipe. As a result, virtually no negative pressure is developed on the input side of the pump. Thus, it is not possible to employ a pump-generated negative pressure or partial vacuum to draw fluid through a tube over the indentation or obstacle in the floor of the fuel tank. Since the outflow from the pump is the only moving fluid available, this flow must be utilized to initiate the siphon but, as already explained, the outflow capacity is not adequate to drive a venturi.

It is known that a vortex amplifier can, in its output passage, develop a negative pressure which can be made quite high depending upon the physical construction of the device. Supply pressures of 10—15 psi (abt. 69×10^3 —abt. 103×10^3 N/m²) are quite common and in the particular environment under consideration, a resulting negative pressure of 4 inches (10×10^2 N/m²) at the output of the vortex is readily obtainable and is sufficient for the intended purpose.

In one form, the transfer conduit may comprise two legs dipping one into each compartment and the vortex amplifier is situated at the junction of the two legs at the maximum height of the transfer conduit, said vortex amplifier serving both to place the two legs in communication with one another and to apply negative pressure sufficient to raise liquid up one leg to the maximum height of the transfer conduit. By proper proportioning of the vortex device, it will operate as a one-way or a two-way pump. In the former case, fluid is constantly pumped from the remote compartment to the compartment with the main fuel pump so long as the differential in levels is within a prescribed range. In the latter case, the device moves the fuel alternatively in one or the other direction again depending upon the difference in levels of liquid with a central dead band and to prevent movement of fluid.

An advantage of this latter arrangement is that only one sender is required to provide a proper fuel level reading. If two-way flow is not provided, then two fuel gauge senders would be required, one in each compartment, together with proper proportioning based on capacity of each compartment in order to provide a relatively accurate reading of remaining fuel. By using a two-way siphon, the levels in the compartments are held within acceptable height variations.

One of the important advantages of the present invention is that the controlling orifice, i.e. the outlet orifice of the vortex device, is physically considerably larger than a venturi of comparable performance capability and is far less subject to clogging or damage in the dirty environment of a gas tank and does not require filtering which would be a service nightmare.

In another aspect, the invention provides an apparatus for delivering liquid to an external utilization device by means of a pump from a first of at least two liquid storage compartments separated by an obstruction, including apparatus

for transferring liquid to the first compartment from a second compartment via a transfer conduit extending over said obstruction and having one leg dipping into the first compartment and a second leg dipping into the second compartment, characterised by a suction-generating device connected to said conduit legs and which is responsive to the total out-flow of the liquid to the utilization device from said first compartment and is arranged to produce transfer of liquid from the second compartment to the first compartment through the transfer conduit as a function of the difference in levels of the liquid in the two compartments, whereby the total pump output goes to the utilization device without diversion of liquid back into the storage compartments.

In a further aspect, the invention provides a liquid delivery system utilizing a pump to deliver liquid fuel from a compartmented tank to a fuel utilization device wherein the compartment has two chambers with a partition therebetween of a predetermined height above the bottom of the chambers, with a transfer conduit extending between said compartments over said partition, characterised in that the pump is located in one of said chambers and the negative pressure at the pump inlet is insufficient to raise the fuel above the partition, and a vortex amplifier device is provided responsive to flow from said pump to the utilization device for producing a sufficiently negative pressure in said transfer conduit to raise the fuel in said conduit above the level of said partition.

Arrangements according to the invention will now be described by way of example and with reference to the accompanying drawings, in which:—

Figure 1 is a simplified diagrammatic view of one embodiment of the present invention.

Figure 2 is a plan view of a vortex amplifier which may be utilized in the system of Figure 1.

Figure 3 is a graph showing the interrelationship of vacuum developed in the output tube of a vortex amplifier and the supply pressure to the amplifier.

Figure 4 is a graph illustrating a particular curve of pressure required to produce a particular quantity of flow in a system with which the present invention is concerned.

Figure 5 is a side view in elevation illustrating the interrelationship between the vortex amplifier, the output tube and the pressure sensing tube of the apparatus of Figure 2 of the accompanying drawings.

Figure 6 is a simplified diagrammatic view of a second embodiment of the present invention.

Figure 7 is a graph illustrating the variation of flow through a vortex amplifier as a function of the ratio of the input diameter of the vortex chamber to the effective output diameter of the output passage.

Figure 8 is a plan view of a vortex amplifier which may be utilized with the embodiments of Figure 6 of the accompanying drawings.

Figure 9 is a simplified diagrammatic view of a

further basic embodiment of the present invention.

Figure 10 is a front diagrammatic view of the vortex chamber and the surrounding passageway employed in Figure 9.

Figure 11 is a detailed view of one form of the interaction region of the device of Figure 10.

Figure 12 is a detailed view of another form of the interaction region of the device of Figure 10.

Figure 13 is a graph illustrating the flow of liquid between compartments as a function of liquid head for the interaction region of Figures 11 and 12.

Referring now specifically to Figure 1 of the accompanying drawings, there is illustrated a gas tank 1 having a vertical indentation 2 in its bottom surface to accommodate a tail pipe or exhaust pipe 3 of the vehicle. It can be seen that below the level of the maximum height of the indentation 2, which level is designated by the reference numeral 4, the gas tank is divided into a left and a right compartment. In systems which utilize throttle body injectors and in some systems which utilize carburetors and diesel injectors, it is becoming common to increase fuel efficiency by employing a sump-type pump 6 for pumping fluid out of the gas tank 1 and to the general vicinity of the engine.

Sump pumps as indicated previously are situated in the liquid and do not have an appreciable negative pressure or, in fact, a readily measurable negative pressure. Also, it is important, due to considerations of utilization of energy, cost and size of the pump, and related economic and efficiency factors, that a little interference with the flow from the pump 6 be encountered in attempting to move fluid from the right compartment of the tank to the left compartment of the tank. Further, due to the environment in which this system is operating and the inaccessibility of the interior of the gas tank, it is important that moving parts not be utilized to initiate transferring of fluid from the right compartment to the left compartment.

In accordance with one embodiment of the present invention, the transferring is accomplished by means of a transfer tube 8 which extends over the vertical obstacle 10 of the tank and into the right and left compartments as viewed in Figure 1 herein. Since there is effectively no negative pressure at the inlet side of the pump 6, it is not possible to utilize the pump directly to suck on the left end of the suction tube 8 to thereby initiate a siphoning action. The present invention, instead of sucking on the end of the tube, creates suction at the vertical apex of the tube 8 to draw liquid from both compartments of the tank 1 to the maximum height of the transfer tube 8 or even higher. Thus, when the fluid in the left compartment falls below the level 4, that is, below the level of the fluid in the right compartment, a siphoning action is initiated and the right compartment is drained concurrently with the left compartment.

The suction at the top of the pipe 8 is applied via

a suction tube 12 which is connected to sense the negative pressure in the outlet passage of a vortex amplifier 14. In Figure 1, the vortex amplifier is connected in series between the pump 6 and outlet conduit 16 which conveys or conducts fluid to the throttle body injector or the carburetor or the injectors of a diesel engine.

The configuration of the vortex amplifier which may be utilized in the series arrangement illustrated in Figure 1 of the accompanying drawings, is illustrated in Figure 2. Fluid which is pumped into a conduit 18 by the pump 6 is introduced via an inlet passage 20 of the vortex amplifier and applied tangentially to a circular chamber 22 of the valve via a passage 24 extending between the passage 20 and the chamber 22. The suction line 12 is situated in the outlet passage 26 preferably in a position of maximum negative static pressure developed in the outlet passage.

In accordance with standard vortex theory, the fluid flowing through the passage 24 enters the chamber 22 tangentially and swirls in an ever radially decreasing vortical or helical pattern and enters the outlet passage 26 at a greatly reduced static pressure and develops a negative static pressure internally of the passage. The dynamic pressure of the fluid, of course, is very high at this point due to the very rapid rotation of the fluid in its transfer from the circumference of the chamber to the small outlet passage.

In the configuration illustrated in Figure 2, islands 28 and 30 are introduced to partially reduce the vorticity in the chamber to thereby reduce the pressure drop in the apparatus. As previously indicated, in a system such as that of the present invention, it is important for the sake of economics and efficiency to utilize as small an amount of energy as possible in driving the pump 6. Thus, as little pressure drop as possible above that required to initiate siphoning should be an end goal.

In this context, reference is made now to the graph of Figure 3 which plots vacuum against supply pressure in a typical vortex amplifier. It will be noted that the four inches suction (abt. 10×10^2 N/m²) which in the particular application for which the invention was developed is essential, was achieved with an available vortex amplifier with a supply pressure to the amplifier of only 4.6 p.s.i. (abt. 32×10^3 N/m²). Lower pressure drops may be achieved. Thus, very great vorticity is not required in the apparatus when a vortex amplifier is utilized in series between the pump 6 and the outlet conduit 16. The suction system must, of course, be designed with the flow characteristics of the total system in mind.

Reference is now made to Figure 4 of the accompanying drawings which illustrates a typical Pressure versus Quantity of flow curve, for a two-stage turbine pump such as that employed as the sump pump in a throttle body injector system of the kind to which the invention is applied. Reference to Figure 4 indicates that a desired flow of 210 pounds (95 kg) of fuel per hour is achieved with a pressure of just over 10 psi (abt.

69×10³ N/m²). If a 4.6 psi (abt. 32×10³ N/m²) drop in line pressure, or even smaller, is achieved, then a total pressure from the pump of only 15 psi (abt. 103×10³ N/m²) or less is required to achieve the desired flow to the engine.

By utilizing the quasi flow straighteners 28 and 30 in Figure 2, the degree of vorticity of the amplifier of Figure 2 is controlled to provide the desired pressure drop. It should be noted again that the vorticity of the fluid and the pressure drop across the amplifier is also a function of the relative diameters of the chamber 22 and the effective diameter of the outlet passage 26 taking into account the reduction in cross-sectional area of the tube 26 resulting from the introduction of the pipe 12 therein. In any event, the overall configuration must be such as to minimize the pressure drop across the valve; 4.6 psi (abt. 32×10³ N/m²) or less in a properly designed system (which consideration eliminates the use of venturis). Thus, referring again to Figure 4, the 10 psi (abt. 69×10³ N/m²) pressure required to obtain 210 pounds (95 kg) per hour of flow under these circumstances may readily be achieved with a supply of pressure of less than 15 psi (abt. 103×10³ N/m²).

Referring now specifically to Figure 5 of the accompanying drawings, the arrangement of the outlet pipe 26 and the vacuum tube pipe 12 is more fully illustrated. The inlet passage 24 is also shown but the islands 28 to 30 have been eliminated for the purpose of clarity. For ease in mechanical assembly, the suction tube 12 enters the outlet tube 26 through the opposite wall of the chamber so that no obstruction is introduced into the passage 26 in bringing the tube 12 out through a side wall.

Referring now specifically to Figure 6 of the accompanying drawings, there is illustrated an arrangement for utilizing what might be called a shunt to sump arrangement wherein the vortex amplifier is not in series with the pump 6 but taps off a portion of the fluid directed to the conduit 16 and utilizes this diverted fluid for the operation of the vortex amplifier and the development of the necessary negative pressure or partial vacuum in the line 12. In this instance, a tap-off pipe 32 supplies fluid to a vortex amplifier 34, the output of which is returned via output passage 36 of the vortex amplifier 34 to the tank 1. In this embodiment in order to minimize the amount of fluid that must be bled from the line 16, a maximum pressure drop is developed across the vortex amplifier. An advantage of this arrangement is that clogging of the vortex amplifier does not impede flow to the injector.

Reference is now made to Figure 7 which is a plot of flow as a function of ratio of the inlet radius of the vortex chamber to the effective radius of the output pipe. It will be noted that, as the ratio increases, the flow through the vortex amplifier decreases rapidly but the curve displays a knee at about a ratio of 4 to 1. Although the flow thereafter continues to decrease, it decreases at a much less rapid rate. An input to output radius

ratio of 4 to 1 may be utilized in the configuration of Figure 6 thereby achieving a relatively small body size.

A suitable vortex amplifier for such a use is illustrated in Figure 8 in which the line 32 is introduced tangentially into a chamber 38 having an inner or annular wall 40 disposed therein and spaced inwardly therefrom to define a passage between the annulus 40 and the outer wall of the chamber 38. The wall 40 is provided with two passages 42 and 44 (or other suitable number of passages) which extend through the wall and into an inner chamber 46 defined by the wall 40 generally tangentially thereto. Output pipe 36 is disposed coaxially with the wall 40 and sensing tube 12 is located within the tube 36. The ratio of the outer wall or the inner surface of the annular wall 40 to the effective radius of the output pipe, that is, the radius taking into account the fact that pipe 12 is enclosed therein, is at least 4 to 1, thereby maximizing the pressure drop across the apparatus. In the consideration of the apparatus of Figure 8, negative pressures of 15 psi (abt. 103×10³ N/m²) and greater have been readily achieved which are obviously more than ample to raise the liquid into siphon tube 8 by far greater than the necessary amount.

The choice of the series or shunt to sump embodiments of Figure 1 or Figure 6, respectively, in a particular system will be determined by many factors which are beyond the control of the designer of the vortex amplifier; specifically, the flow requirements of a particular system, the efficiency of the pump, whether the pump can be readily designed to or has excess pressure or excess flow. If excess pressure is available, then a series amplifier will be utilized. If excess flow is available, then a shunt to sump amplifier will be employed. These facts are readily apparent by reference to Figures 3 and 8 which show respectively the vortex amplifier performance curve achieving the necessary four inches (abt. 10×10² N/m²) suction with a pressure thereacross of 4.6 psi (abt. 32×10³ N/m²) and the large reduction in flow achieved on a 4 to 1 input to output radius ratio showing the low requirements for diversion of fuel for use with a system with excess fuel flow capacity.

In the arrangements thus far described, the vortex amplifiers are employed to raise the level of liquid in a transfer tube to the maximum height of the tube, thus permitting siphoning of fluid from either chamber to the other depending upon in which compartment the level of liquid is the highest. In both systems, the serial and dump to sump systems, unassisted siphoning is employed.

In two further embodiments of the invention, the vortex amplifier is employed as an active element, in series in the transfer system. Referring specifically to Figure 9 of the accompanying drawing, the gas tank 1 again has the sump pump 6 located therein and conduit 16 for carrying fuel from the tank to the engine, not illustrated. A portion of the liquid delivered to conduit 16 is

bled off through conduit 32 to vortex valve 50. The amplifier 50 is located in the transfer tube; in the illustration constituting two lengths of tubing 52 and 54 extending in to the left and right compartment respectively of the tank 1.

The vortex unit 50 of Figure 9 consists of a hollow flat cylindrical vortex chamber 56 (see Figure 10) having tangential inlet passages 58 and a coaxial outlet passage 60. The vortex chamber and outlet is surrounded by a hollow flat cylindrical outer chamber 62 having coaxial outlet and inlet passages 64 and 66 connected to tubes 52 and 54 respectively. The sizes of the passages between the cylinders 56 and 62 are not critical except that the passages must be large enough to permit the required rate of flow between chambers while at the same time establishing rapid enough flow to clear out vapor bubbles. The important configurations and dimensions; however, relate to the region of interaction between the flow through tube 60 and the flow between the two chambers 56 and 62.

Initially reference is made to Figure 13 of the accompanying drawings which is a plot of quantity of flow, Q , as a function of head, H , between the two chambers.

In a "pump" configuration, flow, as indicated by Graph A, is predominately from the right compartment to the left or sump pump containing compartment. The head, H , is positive if the level of fluid in the right compartment is higher than in the left compartment. The graph shows that the vortex amplifier, acting as a pump continues to move fluid to the left compartment by venturi action at the outlet 60 even though it is at a higher level than the right compartment and only stops such pumping when the head is negative by a predetermined design value.

The negative segment of curve A indicates the obvious, if the head in the left compartment is greater than that which can be developed by the vortex amplifier pump, the pump is overwhelmed and fluid flows backwards; i.e. to the right compartment. If only the pumping action is desired, the head necessary to produce this latter effect is greater than that which can be produced as a result of the barrier between compartments and as a practical matter cannot be achieved.

In a "siphon" configuration, the liquid, as indicated by Graph B, flows in both directions; the direction of flow being determined by whether the head, H , is positive or negative. As indicated previously, such an arrangement is desired so that only one sender is required for the fuel gauge.

The dashed line, Graph B1, indicates a pump-assisted siphon having a greater hysteresis than Graph B. As indicated subsequently, the hysteresis is a function of the relative dimensions and locations of the passages 60 and 64 and reference is now made to Figure 11 of the accompanying drawings.

In the configuration of Figure 11, the following dimensions were employed in successful tests;

$$\theta=41^\circ$$

$$d_1=.048\text{---}.052\text{'' (0.122---0.132 cm)}$$

$$d_2=.15\text{'' (0.38 cm)}$$

$$d_3=.43\text{---}.44\text{'' (1.09---1.12 cm)}$$

$$X_1=.025\text{---}.05\text{'' (0.063---0.127 cm)}$$

$$d_4 \text{ (Figure 10)}=0.31\text{'' (0.79 cm)}$$

The value of θ is not critical, 41° being exemplary. It will be seen that the ratio d_2/d_3 is approximately one-third. As to diameters d_1 — d_4 , the relative values are of more importance than the absolute values. As to dimension d_3 , as the ratio of d_3/d_2 gets smaller and/or the overlap X_1 increases, in other words, the volume of the passage between the walls of the outlet 60 and the pipe 64 decreases, the device increasingly exhibits the characteristics of Graph A of Figure 13; the pump characteristics. Initially the curve B is increased in slope and the hysteresis increases, See Graph B¹, until eventually Graph A is approximated. Conversely, as the ratio d_3/d_2 and/or the value of X increases, the Curve B is approached, but the device cannot achieve the function of a perfect siphon, i.e. a curve that passes through the origin with no hysteresis.

It should be noted that the Graph A and the other graphs are asymmetrical with respect to the origin; the preferred direction of movement of the siphon flow being in the direction of flow out of the tube 60.

The configuration of Figure 11 makes a good siphon but a less desirable pump. Specifically, to obtain a good pump, there must be close coupling between the flow from the tube 60 and the liquid in region 66. Due, however, to the thickness of the wall of the outlet 60, the liquid flow out of passage 60, as defined by dashed line 68, is remote from the region 66. Thus, the suction effect is not strong and pumping is not efficient. On the other hand, siphoning requires less direct coupling between the region 66 and the flow from the tube 60, thereby permitting reversal of flow; specifically, flow is more dependent on head, H , than in the case of close coupling.

Reference is now made to Figure 12 of the accompanying drawings wherein the dimensions of Figure 11 apply except as indicated below:

$$d_3$$

$$\text{Pump}=.37\text{---}.39 \text{ (0.94---0.99 cm)}$$

$$\text{Siphon}=.44\text{---}.48 \text{ (1.12---1.22 cm)}$$

Thus, in the case of a pump the ratio d_2/d_3 is in the range of 0.385 to 0.41; and in the case of the siphon it is 0.312—0.341. In this embodiment of the invention, the outer wall or surface 70 of the outlet 60 is tapered whereby by controlling the angle θ , and/or the diameter d_3 and/or the dimension X_1 (Fig. 11), the coupling between the flow from outlet 60 and region 66 may be readily determined and pump or siphon operation preferred. As previously indicated and as brought out by the dimensions of d_3 , above, with all other dimensions being the same as in Figure 11, pump operation is achieved with close coupling,

$d_3=.37-.39$ (0.94—0.99 cm) and excellent siphon operation is achieved with looser coupling, $d_3=.46$ (1.22 cm) etc.

The present invention has been described for utilization in a particular environment. However, it is apparent that this system may be utilized wherever the problems discussed herein are encountered.

Claims

1. An apparatus for pumping liquid from a compartmentalized container, comprising a container (1) having at least two compart-

ments,
an obstacle (2) separating said compartments,
a transfer conduit (8) extending between said compartments over said obstacle, and

a pump (6) for pumping liquid out of said container through an outlet (16) and for ingesting liquid into said pump through an inlet at a low negative pressure with said inlet communicating with one of said compartments, characterised by a vortex amplifier (14) responsive to flow of liquid from the outlet (18) of said pump for developing a negative pressure which is applied to said transfer conduit and is sufficient to lift liquid in at least one of said compartments to the maximum height of said conduit.

2. An apparatus as defined in Claim 1 wherein the pump is a sump-type pump immersed in the liquid with a negative pressure at its inlet less than that required to lift liquid in one of said compartments over the obstacle, and the vortex amplifier receives input liquid from the outlet of said pump.

3. An apparatus as defined in Claim 2 wherein said vortex amplifier has a central outlet passage (26) and the negative pressure is applied through a suction pipe (12) extending into a region of negative pressure in said outlet passage of said vortex amplifier.

4. An apparatus as defined in Claim 2 wherein said vortex amplifier comprises a flat hollow cylindrical chamber (56) and an outlet passage (60) coaxial with the axis of said chamber, and means (58) for introducing liquid flowing from the outlet of the pump into said chamber tangential to the inner circumference thereof, and

said transfer conduit (8) communicates with a region of negative pressure in said outlet passage of said vortex amplifier.

5. An apparatus as defined in Claim 2 or Claim 3 wherein the vortex amplifier is connected in series in the outlet pipe of the pump.

6. An apparatus as defined in Claim 2 or Claim 3 or Claim 4 wherein the vortex amplifier receives a part only of the liquid output of the pump via a branch pipe (32).

7. An apparatus as defined in any of Claims 1 to 4 and 6, wherein the transfer conduit comprises two legs (52, 54) dipping one into each compartment and the vortex amplifier (50) is situated at the junction of the two legs at the maximum height of the transfer conduit, said vortex ampli-

fier serving both to place the two legs in communication with one another and to apply negative pressure sufficient to raise liquid up one leg to the maximum height of the transfer conduit.

8. An apparatus for delivering liquid to an external utilization device by means of a pump from a first of at least two liquid storage compartments separated by an obstruction, including apparatus for transferring liquid to the first compartment from a second compartment, via a transfer conduit (8) extending over said obstruction (2), and having one leg dipping into the first compartment and a second leg dipping into the second compartment, characterised by

a suction-generating device connected to said conduit legs and which is responsive to the total out-flow of the liquid to the utilization device from said first compartment and is arranged to produce transfer of liquid from the second compartment to the first compartment through the transfer conduit as a function of the difference in levels of the liquid in the two compartments, whereby the total pump output goes to the utilization device without diversion of liquid back into the storage compartments.

9. An apparatus as defined in Claim 8 wherein the suction generating device is a vortex amplifier.

10. An apparatus as defined in Claim 1 wherein the vortex amplifier comprises

a vortex chamber (56) having a centrally located egress orifice (60), and an enclosure (62) defining a continuous flow path extending about the periphery of said vortex chamber, and wherein

said transfer conduit has two conduit legs (52, 54) dipping one into each compartment which conduit legs at their upper ends enter opposed ends of said enclosure,

said egress orifice directs liquid into an end (64) of one of said conduit legs extending into said enclosure, and

injection means (58) is provided for introducing liquid from the pump output tangentially into said vortex chamber generally at a location at its maximum diameter.

11. An apparatus as defined in Claim 10 wherein the egress orifice of said vortex amplifier extends into said end of said one of said conduit legs, and

said egress orifice is defined by an annular wall that has an internal outward taper towards its end.

12. An apparatus as defined in Claim 11 wherein the ratio d_2/d_3 of the diameters of the exterior surface of said orifice wall and the interior surface of said one of said conduits is approximately one-third.

13. An apparatus as defined in Claim 12 wherein the angle of taper of said wall is approximately 41° .

14. An apparatus as defined in Claim 13 wherein said wall extends into said one of said conduits by 0.063 to 0.127 cm.

15. An apparatus as defined in Claim 10 wherein said egress orifice of said vortex ampli-

5

10

15

20

25

30

35

40

45

50

55

60

65

7

fier extends into said end of said one of said conduits,

and said egress orifice is defined by an annular wall that is tapered on its exterior surface (70) to a thickness of minimum dimension at its end.

16. An apparatus as defined by Claim 15 wherein the ratio d_2/d_3 of the diameters of the exterior surface of said orifice wall at the beginning of the taper and the inner diameter of said conduit end is in the range of 0.385 to 0.41.

17. An apparatus as defined in Claim 15 wherein the ratio d_2/d_3 of the diameters of the exterior surface of said wall at the beginning of the taper and the inner diameter of said conduit end is in the range of 0.312 to 0.341.

18. A liquid delivery system utilizing a pump (6) to deliver liquid fuel from a compartmented tank (1) to a fuel utilization device wherein the compartment has two chambers with a partition (2) therebetween of a predetermined height above the bottom of the chambers,

with a transfer conduit (8) extending between said compartments over said partition, characterised in that

the pump is located in one of said chambers and the negative pressure at the pump inlet is insufficient to raise the fuel above the partition,

and a vortex amplifier device (14, 50) is provided responsive to flow from said pump to the utilization device for producing a sufficiently negative pressure in said transfer conduit to raise the fuel in said conduit above the level of said partition.

19. An apparatus as defined in Claim 8 wherein the suction generating device is

a vortex device having an input (24) and an output passage (26) connected in series in

an outflow pipe (18, 16) to the utilization device, and a further conduit (12) in

communication with said transfer conduit is connected to sense a negative pressure in the output passage of the vortex device.

Patentansprüche

1. Einrichtung zum Pumpen von Flüssigkeit aus einem in Kammern unterteilten Container, mit

—einem Container (1) mit wenigstens zwei Kammern,

—einem Hindernis (2), das die Kammern trennt,

—einer Übertragungsleitung (8), die sich zwischen den Kammern über das Hindernis hinweg erstreckt, und

—einer Pumpe (6) zum Pumpen von Flüssigkeit aus dem genannten Container heraus durch einen Auslaß (16) und zum Einleiten von Flüssigkeit in die Pumpe durch einen Einlaß bei einem niedrigen negativen Druck, wobei der Einlaß mit einer der Kammern in Verbindung steht,

gekennzeichnet durch

einen Wirbelverstärker (14), der auf eine Strömung von Flüssigkeit aus dem Auslaß (18) der genannten Pumpe anspricht und einen negativen Druck entwickelt, der an die genannte Verbindungsleitung angelegt ist und ausreicht, um Flüssigkeit in wenigstens einer der Kammern auf die maximale Höhe der Leitung anzuheben.

2. Einrichtung nach Anspruch 1, dadurch gekennzeichnet, daß die Pumpe eine Sumpfpumpe ist, die in die Flüssigkeit eingetaucht ist und an ihrem Einlaß einen negativen Druck hat, der geringer ist als der, der erforderlich ist, um Flüssigkeit in einer der Kammern über das Hindernis hinweg anzuheben, und daß der Wirbelverstärker Eingangsf Flüssigkeit von dem Auslaß der genannten Pumpe aufnimmt.

3. Einrichtung nach Anspruch 2, dadurch gekennzeichnet, daß der Wirbelverstärker einen zentralen Auslaßkanal (26) aufweist und daß der negative Druck über ein Saugrohr (12) zugeführt ist, das sich in einen Bereich negativen Druckes in dem Auslaßkanal des Wirbelverstärkers erstreckt.

4. Einrichtung nach Anspruch 2, dadurch gekennzeichnet, daß

—der Wirbelverstärker eine flache, hohle, zylindrische Kammer (56) und einen Auslaßkanal (60) aufweist, der koaxial zur Achse der genannten Kammer ist, und

—Mittel zur Einleitung von von dem Auslaß der Pumpe fließender Flüssigkeit in die Kammer tangential zu der inneren Wandung derselben, und

—daß die Verbindungsleitung mit einem Bereich negativen Druckes in dem genannten Auslaßkanal des Wirbelverstärkers in Verbindung steht.

5. Einrichtung nach Anspruch 2 oder 3, dadurch gekennzeichnet, daß der Wirbelverstärker mit dem Auslaßrohr der Pumpe in Reihe geschaltet ist.

6. Einrichtung nach Anspruch 2, 3 oder 4, dadurch gekennzeichnet, daß der Wirbelverstärker nur einen Teil der Austrittsflüssigkeit aus der Pumpe über eine Abzweigleitung (32) erhält.

7. Einrichtung nach einem der Ansprüche 1 bis 4 und 6, dadurch gekennzeichnet, daß die Übertragungsleitung zwei Schenkel (52, 54) aufweist, die jeweils in eine der Kammern eintauchen, und daß der Wirbelverstärker (50) am Verbindungspunkt der beiden Schenkel am Ort maximaler Höhe der Verbindungsleitung angeordnet ist, und daß der Wirbelverstärker dazu dient, sowohl die beiden Schenkel miteinander in Verbindung zu bringen als auch negativen Druck anzulegen, um Flüssigkeit in einem Schenkel auf die maximale Höhe der Verbindungsleitung anzuheben.

8. Einrichtung zur Abgabe von Flüssigkeit an eine externe Verbrauchseinrichtung mittels einer Pumpe aus einer ersten von wenigstens zwei Vorratskammern, die durch ein Hindernis voneinander getrennt sind, mit einer Einrichtung zur Übertragung von Flüssigkeit zu der ersten Kammer von einer zweiten Kammer über eine Übertragungsleitung (8), die sich über das Hindernis (2) hinwegerstreckt und mit einem Schenkel in die erste Kammer eintaucht und mit einem zweiten Schenkel in die zweite Kammer,

gekennzeichnet durch

—eine sogerzeugende Einrichtung, die mit den Leitungsschenkeln verbunden ist und auf den Gesamtausfluß der Flüssigkeit zu der Verbrauchs-

einrichtung aus der ersten Kammer anspricht und eine Übertragung von Flüssigkeit von der zweiten Kammer zu der ersten Kammer durch die Verbindungsleitung als Funktion der Differenz der Niveaus der Flüssigkeit in den beiden Kammern überträgt, wobei der gesamte Pumpenauslaß zu der Verbrauchseinrichtung geht, ohne daß ein Teil von Flüssigkeit in die Vorratskammern zurückgeht.

9. Einrichtung nach Anspruch 8, dadurch gekennzeichnet, daß die sogerzeugende Einrichtung ein Wirbelverstärker ist.

10. Einrichtung nach Anspruch 1, dadurch gekennzeichnet, daß der Wirbelverstärker aufweist

—eine Wirbelkammer (56) mit einer zentral angeordneten Austrittsöffnung (60) und einer Umhüllung (62), die einen kontinuierlichen Strömungspfad definiert, der sich um den Umfang der Wirbelkammer erstreckt, und wobei

—die genannte Übertragungsleitung zwei Leitungsschenkel (52, 54) aufweist, die jeweils in eine der Kammern eintauchen und jeweils mit ihren oberen Enden auf gegenüberliegenden Seiten in die Umhüllung eintreten,

—wobei die genannte Austrittsöffnung Flüssigkeit in ein Ende (64) von einer der genannten, sich in die Umhüllung erstreckenden Leitungsschenkel richtet, und

—Einspritzmittel (58) zur Einleitung von Flüssigkeit von dem Pumpenauslaß tangential in die Wirbelkammer im wesentlichen an einem Ort ihres maximalen Durchmessers.

11. Einrichtung nach Anspruch 10, dadurch gekennzeichnet, daß die Austrittsöffnung des Wirbelverstärkers sich in das Ende von einem der genannten Leitungsschenkel erstreckt, und

—daß die Austrittsöffnung durch eine Umfangswandung gebildet ist, die sich in Richtung auf ihr Ende kegelig erweitert.

12. Einrichtung nach Anspruch 11, dadurch gekennzeichnet, daß das Verhältnis d_2/d_3 der Durchmesser der äußeren Fläche der genannten Öffnungswandung und der Innenfläche einer der genannten Leitungen ungefähr ein Drittel ist.

13. Einrichtung nach Anspruch 12, dadurch gekennzeichnet, daß der Kegelwinkel der genannten Wandung ungefähr 41° beträgt.

14. Einrichtung nach Anspruch 13, dadurch gekennzeichnet, daß sich die genannte Wandung um ungefähr 0,063 bis 0,127 cm in eine der genannten Leitungen erstreckt.

15. Einrichtung nach Anspruch 10, dadurch gekennzeichnet, daß die genannte Austrittsöffnung des Wirbelverstärkers sich in das Ende einer der genannten Leitungen erstreckt,

—und daß die Austrittsöffnung durch eine Umfangswandung gebildet ist, die sich auf ihrer Außenfläche (70) an ihrem Ende bis zu einer Dicke minimaler Ausdehnung verjüngt.

16. Einrichtung nach Anspruch 15, dadurch gekennzeichnet, daß das Verhältnis d_2/d_3 der Durchmesser der äußeren Fläche der genannten Öffnungswandung zu Beginn der Verjüngung und der innere Durchmesser des genannten Leitungsendes im Bereich von 0,385 bis 0,41 liegt.

5

17. Einrichtung nach Anspruch 15, dadurch gekennzeichnet, daß das Verhältnis d_2/d_3 der Durchmesser der äußeren Fläche der genannten Wandung zu Beginn der Verjüngung und der innere Durchmesser des genannten Leitungsendes im Bereich von 0,312 bis 0,341 liegt.

10

18. Flüssigkeitsabgabesystem unter Verwendung einer Pumpe (6) zur Abgabe von flüssigem Brennstoff aus einem in Kammern unterteilten Tank (1) an eine Brennstoffverbrauchseinrichtung, wobei die Kammer zwei Unterkammern mit einer Unterteilung (2) dazwischen vorbestimmter Höhe oberhalb des Boden der Unterkammern aufweist,

15

—mit einer Verbindungsleitung (8), die sich zwischen den Kammern über die Unterteilung hinweg erstreckt,

dadurch gekennzeichnet, daß

—die Pumpe in einer der Kammern angeordnet ist und der negative Druck am Pumpeneinlaß nicht ausreicht, um den Brennstoff über die Unterteilung anzuheben,

20

—und daß eine Wirbelverstärkereinrichtung (14, 50) vorgesehen ist, die auf Strömung von der Pumpe zu der Verbrauchseinrichtung anspricht, um einen ausreichenden negativen Druck in der Verbindungsleitung zu erzeugen und den Brennstoff in der genannten Leitung über das Niveau der Unterteilung anzuheben.

25

19. Einrichtung nach Anspruch 8, dadurch gekennzeichnet, daß die sogerzeugende Einrichtung eine Wirbeleinrichtung mit einem Einlaß (24) und einem Auslaßkanal (26), der mit einem Austrittsrohr (18, 16) zu der Verbrauchseinrichtung in Verbindung steht, und mit einer weiteren Leitung (12) ist, die in Verbindung mit der Übertragungsleitung steht und angeschlossen ist, um negativen Druck in dem Auslaßkanal der Wirbeleinrichtung abzutasten.

30

35

40

Revendications

1. Appareil pour pomper du liquide à partir d'un conteneur compartimenté, comprenant:

45

—un conteneur (1) comportant au moins deux compartiments,

—un obstacle (2) séparant lesdits compartiments,

50

—un conduit de transfert (8) s'étendant entre lesdits compartiments par-dessus ledit obstacle, et

55

—une pompe (6) pour pomper du liquide à l'extérieur dudit conteneur par une sortie (16) et pour envoyer du liquide dans ladite pompe par une entrée à une faible dépression, ladite entrée communiquant avec l'un desdits compartiments, caractérisé par

60

un amplificateur tourbillonnaire (14) réagissant à l'écoulement de liquide de la sortie (18) de ladite pompe en engendrant une dépression qui est appliquée audit conduit de transfert et est suffisante pour faire monter du liquide dans l'un au moins desdits compartiments à la hauteur maximale dudit conduit.

65

2. Appareil selon la revendication 1, dans lequel la pompe est une pompe de type immergée,

immergée dans le liquide, avec une dépression à son entrée inférieure à celle nécessaire pour faire monter du liquide dans l'un desdits compartiments par-dessus l'obstacle, et l'amplificateur tourbillonnaire reçoit du liquide d'entrée à la sortie de ladite pompe.

3. Appareil selon la revendication 2, dans lequel ledit amplificateur tourbillonnaire comporte un passage de sortie central (26) et dans lequel la dépression est appliquée par l'intermédiaire d'un tuyau d'aspiration (12) s'étendant jusqu'à l'intérieur d'une région de dépression dans ledit passage de sortie dudit amplificateur tourbillonnaire.

4. Appareil selon la revendication 2, dans lequel ledit amplificateur tourbillonnaire comprend une chambre cylindrique creuse plate (56) et un passage de sortie (60) ayant pour axe, l'axe de ladite chambre, et des moyens (58) pour introduire du liquide s'écoulant de la sortie de la pompe dans ladite chambre tangentiellement à sa circonférence intérieure, et dans lequel ledit conduit de transfert (8) communique avec une région de dépression dans ledit passage de sortie dudit amplificateur tourbillonnaire.

5. Appareil selon la revendication 2 ou 3, dans lequel l'amplificateur tourbillonnaire est monte en série dans le tuyau de sortie de la pompe.

6. Appareil selon les revendications 2, 3 ou 4, dans lequel l'amplificateur tourbillonnaire reçoit une partie seulement du débit de liquide de la pompe par l'intermédiaire d'un tuyau de dérivation (32).

7. Appareil selon l'une quelconque des revendications 1 à 4 et 6, dans lequel le conduit de transfert comprend deux branches (52, 54) plongeant chacune dans l'un des compartiments, et l'amplificateur tourbillonnaire (50) est situé à la jonction des deux branches à la hauteur maximale du conduit de transfert, ledit amplificateur tourbillonnaire servant à la fois à mettre les deux branches en communication entre elles et à appliquer une dépression suffisante pour faire monter du liquide sur une branche à la hauteur maximale du conduit de transfert.

8. Appareil pour envoyer du liquide à un dispositif utilisateur extérieur au moyen d'une pompe à partir d'un premier d'au moins deux compartiments de stockage de liquide séparés par un obstacle, comprenant un appareil pour transférer du liquide au premier compartiment à partir d'un second compartiment, par l'intermédiaire d'un conduit de transfert (8) s'étendant par-dessus ledit obstacle (2), et dont une branche plonge dans le premier compartiment, tandis qu'une seconde branche plonge dans le second compartiment caractérisé par un dispositif générateur d'aspiration relié auxdites branches du conduit et réagissant au débit total du liquide à destination du dispositif utilisateur à partir dudit premier compartiment, et agencé pour produire un transfert de liquide du second compartiment au premier compartiment par l'intermédiaire du conduit de transfert, en fonction de la différence des niveaux du liquide dans les deux compartiments, de telle sorte que le débit total de la pompe rejoint le

dispositif utilisateur sans détournement de liquide le ramenant dans les compartiments de stockage.

9. Appareil selon la revendication 8, dans lequel le dispositif générateur d'aspiration est un amplificateur tourbillonnaire.

10. Appareil selon la revendication 1, dans lequel l'amplificateur tourbillonnaire comprend une chambre de tourbillonnement (56) comportant un orifice de sortie (60) disposé centralement, et une enceinte (62) délimitant un trajet d'écoulement continu s'étendant sur la périphérie de ladite chambre de tourbillonnement, et dans lequel ledit conduit de transfert comporte deux branches de conduit (52, 54) plongeant chacune dans un compartiment, branches de conduit qui pénètrent, à leurs extrémités supérieures, dans des extrémités opposées de ladite enceinte, ledit orifice de sortie dirige du liquide dans une extrémité (64) de l'une desdites branches de conduit s'étendant dans ladite enceinte, et des moyens d'injection (58) sont prévus pour introduire du liquide de la sortie de la pompe tangentiellement dans ladite chambre de tourbillonnement, en général à un emplacement situé au niveau de son diamètre maximum.

11. Appareil selon la revendication 10, dans lequel l'orifice de sortie dudit amplificateur tourbillonnaire s'étend à l'intérieur de ladite extrémité de ladite première branche de conduit, et ledit orifice est délimité par une paroi annulaire qui présente une conicité extérieure interne vers son extrémité.

12. Appareil selon la revendication 11, dans lequel le rapport d_2/d_3 des diamètres de la surface extérieure de ladite paroi d'orifice et de la surface intérieure dudit premier conduit est d'environ un tiers.

13. Appareil selon la revendication 12, dans lequel l'angle de cône de ladite paroi est d'environ 41°.

14. Appareil selon la revendication 13, dans lequel ladite paroi s'étend à l'intérieur dudit premier conduit sur 0,063 à 0,127 cm.

15. Appareil selon la revendication 10, dans lequel ledit orifice de sortie dudit amplificateur tourbillonnaire s'étend à l'intérieur de ladite extrémité dudit premier conduit, et ledit orifice de sortie est délimité par une paroi annulaire qui est conique à sa surface extérieure (70) jusqu'à atteindre une épaisseur de dimension minimale à son extrémité.

16. Appareil selon la revendication 15, dans lequel le rapport d_2/d_3 du diamètre de la surface extérieure de ladite paroi d'orifice au début du cône et du diamètre intérieur de ladite extrémité de conduit est comprise entre 0,385 et 0,41.

17. Appareil selon la revendication 15, dans lequel le rapport d_2/d_3 du diamètre de la surface extérieure de ladite paroi au début du cône et du diamètre intérieur de ladite extrémité de conduit est compris entre 0,312 et 0,341.

18. Système de distribution de liquide utilisant une pompe (6) pour débiter du carburant liquide d'un réservoir (1) compartimenté à un dispositif

utilisateur, dans lequel le compartiment comporte deux chambres avec une cloison de séparation (2) entre elles d'une hauteur prédéterminée au-dessus du fond des chambres, comportant un conduit de transfert (8) s'étendant entre lesdits compartiments par-dessus ladite cloison de séparation, caractérisé en ce que la pompe est placée dans l'une des chambres et la dépression à l'entrée de la pompe est insuffisante pour faire monter le carburant au-dessus de la cloison de séparation, et un dispositif amplificateur tourbillonnaire (14, 50) est prévu et réagit à l'écoulement de ladite pompe au dispositif utilisateur en engen-

drant une dépression suffisante dans ledit conduit de transfert pour faire monter le carburant dans ledit conduit au-dessus du niveau de ladite cloison de séparation.

5 19. Appareil selon la revendication 8, dans lequel le dispositif générateur d'aspiration est un dispositif tourbillonnaire comportant une entrée (24) et un passage de sortie (26) en série dans un tuyau de sortie (18, 16) à destination du dispositif
10 utilisateur, et un autre conduit (12) en communication avec ledit conduit de transfert est connecté pour détecter une dépression dans le passage de sortie du dispositif tourbillonnaire.

15

20

25

30

35

40

45

50

55

60

65

11

FIG. 1

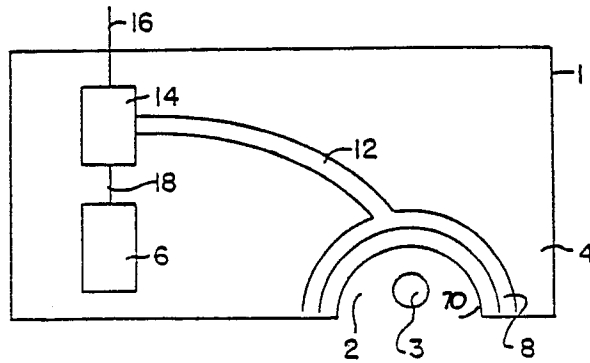

FIG. 2

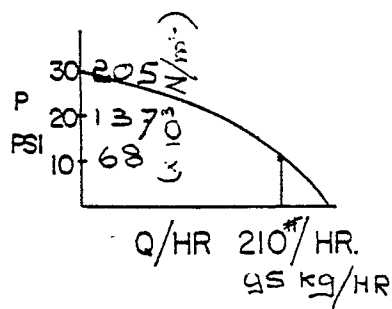
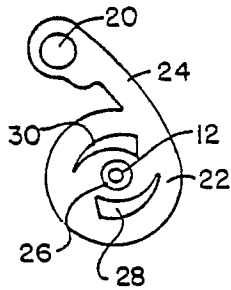

FIG. 4

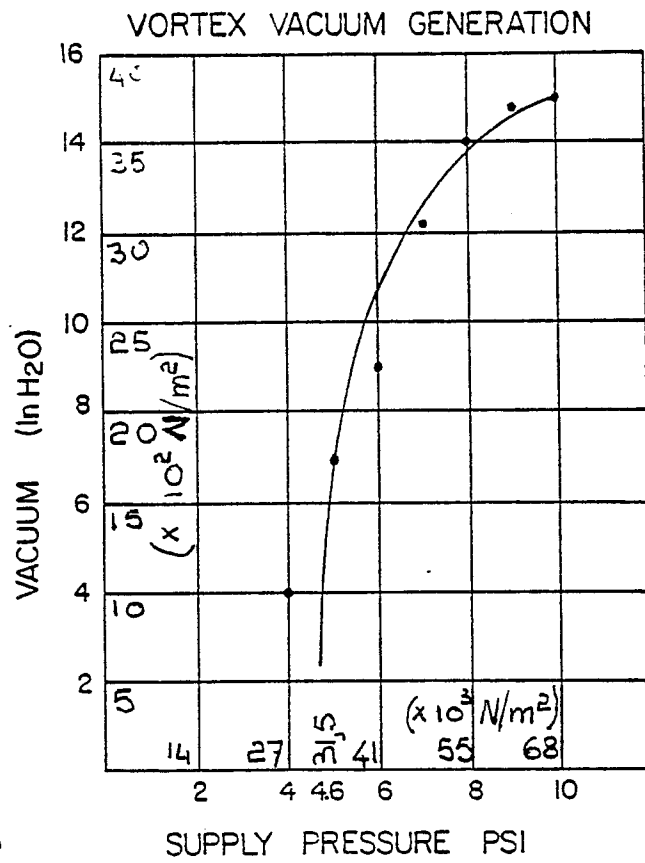

FIG. 3

FIG. 5

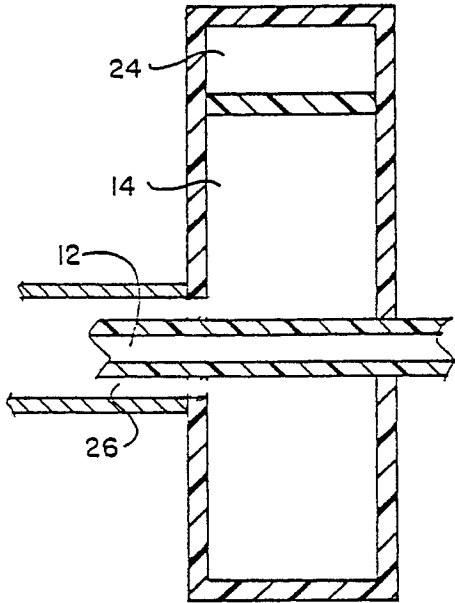

FIG. 7

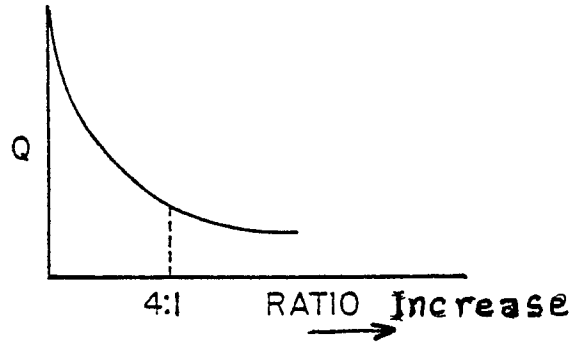

FIG. 6

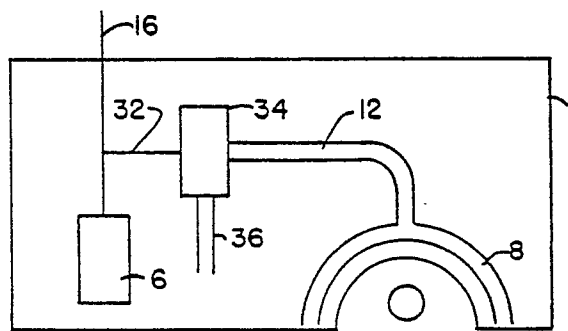

FIG. 8

