

12 **EUROPEAN PATENT APPLICATION**

21 Application number: **84103799.7**

51 Int. Cl.⁴: **A 47 G 21/18**

22 Date of filing: **05.04.84**

30 Priority: **11.04.83 JP 53610/83**
17.08.83 JP 127196/83

43 Date of publication of application:
02.05.85 Bulletin 85/18

84 Designated Contracting States:
CH DE FR IT LI NL SE

71 Applicant: **SANYO SHIKI KABUSHIKI KAISHA**
2235-3 Denpo
Fuji-shi Shizuoka-ken(JP)

72 Inventor: **Inaba, Koichi**
1994 Denpo Takishita
Fuji-shi Shizuoka-ken(JP)

74 Representative: **Zipse + Habersack**
Kemnatenstrasse 49
D-8000 München 19(DE)

54 **Telescopic drinking straw.**

57 Improvement in extensible and contractible double straw (10) consisting of an inner straw (11) a base end of which is formed as a diameter enlarged portion (12) and an outer straw (13) a front end of which is formed as a diameter reduced portion (14), said improvement comprising a front extension (16) of said diameter reduced portion (14) formed as a tapered portion or as a cylindrical or tubular portion.

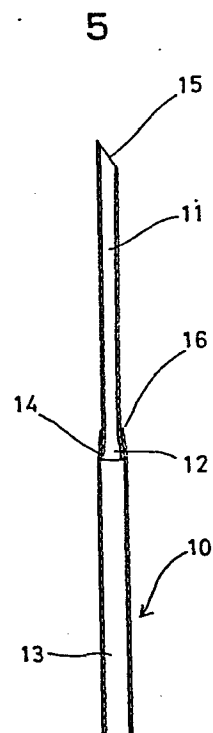

IMPROVEMENT IN EXTENSIBLE AND CONTRACTIBLE
DOUBLE STRAW

The present invention relates to an improvement of extensible and contractible double straw consisting of an inner straw and an outer straw telescopically slidable relative to each other.

A straw to be attached to a beverage container preferably should be longer than a depth of said container in order that the straw might not fall into said container during drinking. However, the straw sufficiently long to be convenient for drinking will be necessarily longer than the beverage container itself and, in consequence, it is difficult for such a straw to be attached to the container in a convenient manner. As a result, a demand for a straw has arisen, which is adapted to be contractible when attached to the container and to be extensible for use.

There has already been proposed an extensible and contractible double straw consisting of an inner straw and an outer straw telescopically slidable with respect to each other. In such double straw of prior art, as shown by Fig. 1, the inner straw 1 is provided at its base end with a diameter enlarged portion 2 while the outer straw 3 is provided at its front end with a diameter reduced portion 4. Accordingly, the inner and outer straws telescopically extended into a unitary straw tend to be bent at

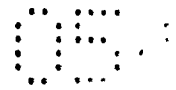

a position around which the diameter enlarged portion is engaged with the diameter reduced portion, as seen in Fig. 1, so that such point of engagement cannot be stable for conveniently drinking.

A principal object of the present invention is, in view of the problems as mentioned above, to provide a novel extensible and contractible double straw so improved so that said bending of the double straw at the point of engagement may be surely avoided.

This object is achieved, in accordance with the present invention, by improvement in extensible and contractible double straw consisting of an inner straw and an outer straw, said improvement comprising a base end of the inner straw formed as a diameter enlarged portion, a front end of the outer straw formed as a diameter reduced portion and a front extension of said diameter reduced portion formed as a tapered portion or as a cylindrical or tubular portion.

Now the present invention will be described more in detail with respect to preferred embodiments shown by the drawings.

Fig. 1 shows the telescopically extensible and contractible double straw of prior art as fully extended;

Figs. 2 through 5 show a preferred embodiment of the present invention, Fig. 2 showing this as fully contracted, Fig. 3 being an axial section corresponding to Fig. 2, Fig. 4 showing this as fully extended, and

Fig. 5 being an axial section corresponding to Fig. 4; and Figs. 6 through 9 show another preferred embodiment, Fig. 6 being a front view showing this as fully contracted, Fig. 7 being an axial section corresponding to Fig. 6, Fig. 8 being a front view showing this as fully extended, and Fig. 9 being an axial section corresponding to Fig. 8.

As shown, an extensible and contractible double straw 10 consists of an inner straw 11 and an outer straw 13. A front end of the inner straw 11 is obliquely cut away so as to form a pointed end 15 in order to facilitate not only insertion of the straw into a beverage container but also assembly of the extensible and contractible double straw 10, i.e., insertion of the inner straw 11 into the outer straw 13. A base end of the inner straw 11, namely an end of the inner straw 11 destined to be engaged with the outer straw 13 is formed as a diameter enlarged portion 12.

An end of the outer straw 13 destined to be engaged with the inner straw 11, namely, a front end of this outer straw 13 is formed as a diameter reduced portion 14 and an end of said diameter reduced portion 14 is prolonged by a suitable length in the direction along which the inner straw 11 is extended so as to form a tapered portion 16. An inner diameter of this tapered portion 16 is dimensioned not to obstruct a slidable movement of the inner straw 11 and substantially corresponds to an outer diameter of said inner straw 11. Thus, when the straw is fully extended, the diameter enlarged portion 12 of the inner straw 11 comes into engagement with the diameter reduced portion 14 of the outer straw 13, thereby the inner straw 11 is prevented from

slipping out of the outer straw 13 and the inner straw 11 is held further by the tapered portion 16 of the outer straw 13. A possible bending of these inner and outer straws at the point of engagement is thus effectively prevented.

Figs. 6 through 9 show another preferred embodiment of the present invention and the parts in these figures which are same as those in Figs. 2 through 5 are designated by the same reference numerals as in Figs. 2 through 5.

In this embodiment, said outer straw 13 is provided adjacent the front end thereof with an inwardly directed stopper 17 to prevent the inner straw 11 from retracting into the outer straw 13 when the double straw has been fully extended and the base end of the outer straw 13 also is formed with a diameter reduced portion 18 to prevent the inner straw once inserted into the outer straw 13 from unintentionally slipping out of the outer straw 13.

Although said inwardly directed stopper 17 is shown in the form of four inwardly directed projections, these inwardly directed projections may be replaced by a ring-shaped stopper extending around the peripheral wall of the outer straw.

As will be apparent from the foregoing description, the extensible and contractible double straw improved according to the present invention is characterized by such arrangement that the inner straw is provided at its base end with the diameter enlarged portion, the outer straw is provided at its front end with the diameter reduced portion and the end of this diameter reduced portion is slightly prolonged so as to form the tapered portion so that said diameter enlarged portion is engaged with

said diameter reduced portion and thereby the inner straw is effectively prevented from slipping out of the outer straw. Furthermore, the inner straw is additionally held by the tapered portion of the outer straw and, therefore, both the inner straw and the outer straw are kept against a bending even when a diameter difference of these inner and outer straws is relatively large. This is advantageous in that the extensible and contractible double straw provides a high convenience for drinking.

In the embodiment in which the outer straw is provided adjacent its front end with the inwardly directed stopper, this stopper prevents the inner straw from retracting into the outer straw when the double straw has been fully extended, thereby surely maintains the double straw fully extended and assures reliable handling. When the base end of the outer straw is formed with the diameter reduced portion, this diameter reduced portion serves to prevent the inner straw once inserted into the outer straw from unintentionally slipping out of the outer straw and thus maintains the inner and outer straws in pair.

C l a i m s

1. Improvement in extensible and contractible double straw (10) consisting of an inner straw (11) a base end of which is formed as a diameter enlarged portion (12) and an outer straw (13) a front end of which is formed as a diameter reduced portion (14), characterized in that there is provided a front extension (16) of said diameter reduced portion (14) formed as a tapered portion or as a cylindrical or tubular portion.

2. Improvement in extensible and contractible double straw according to claim 1, characterized in that the outer straw (13) is provided adjacent the front end thereof with an inwardly directed stopper (17) to assure engagement of the base end of the inner straw (11) with the outer straw (13) when these inner and outer straws have been fully extended in a telescopic manner and thereby to prevent the inner straw (11) from retracting into the outer straw (13).

3. Improvement in extensible and contractible double straw according to claim 1 or 2, characterized in that a base end of the outer straw (13) also is formed with a diameter reduced portion (18) to prevent the inner straw (11) from slipping out of the outer straw.

1

2

3

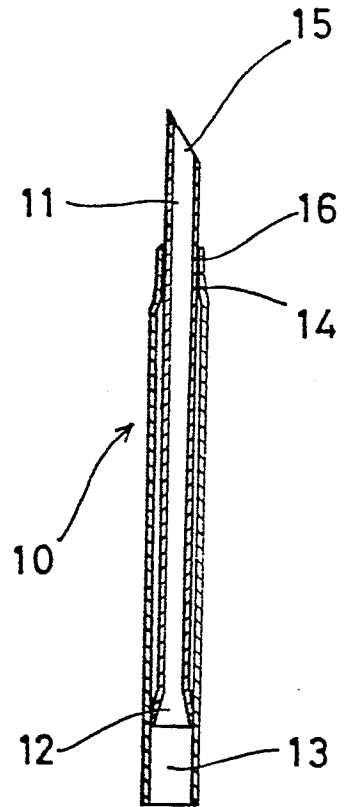
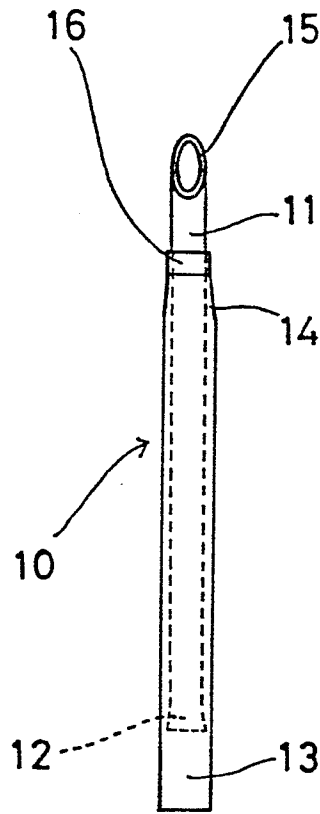
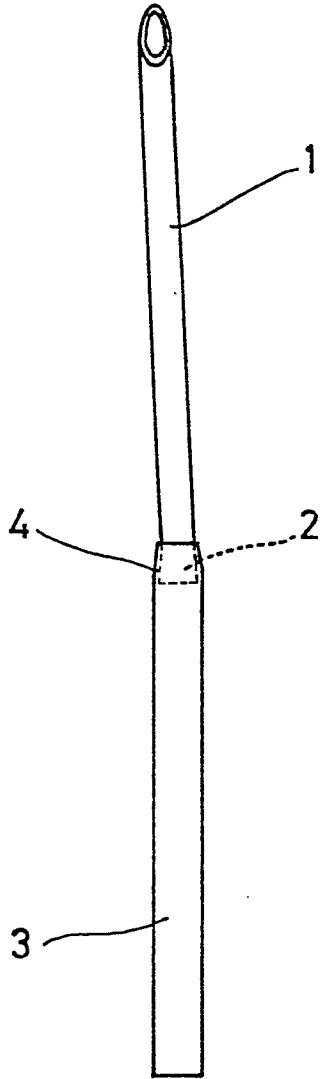

4

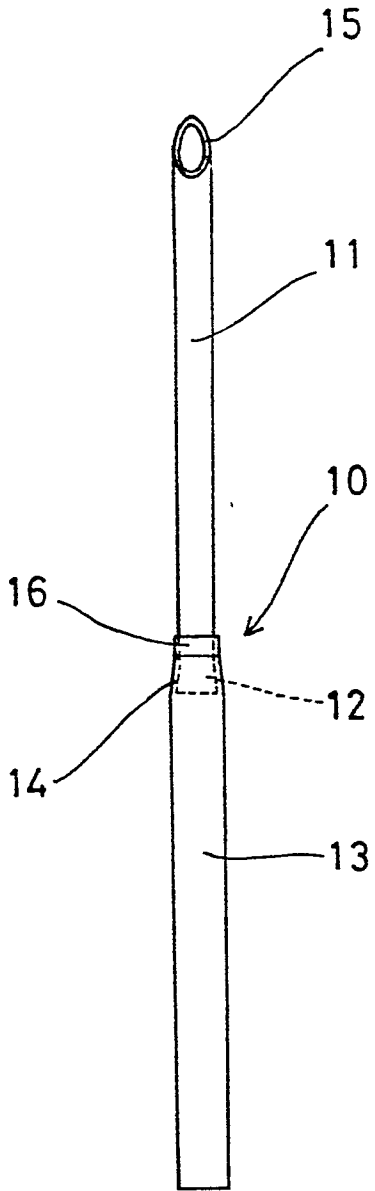

5

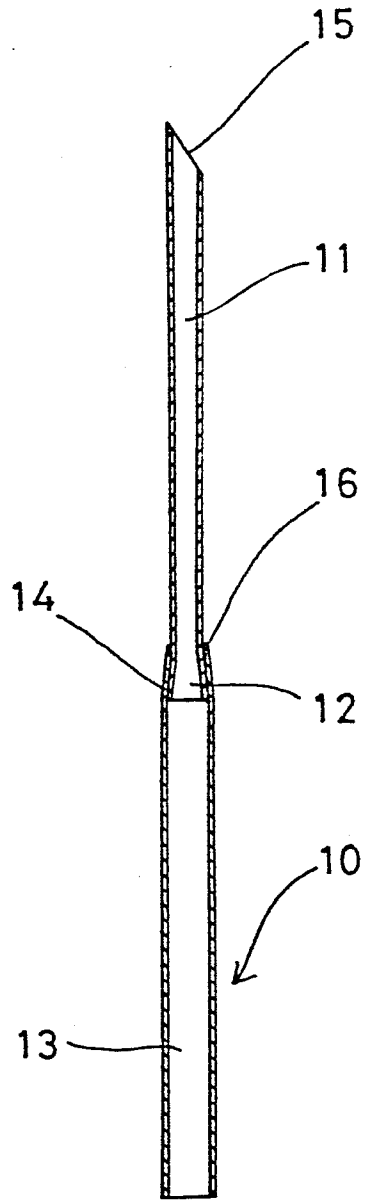

6

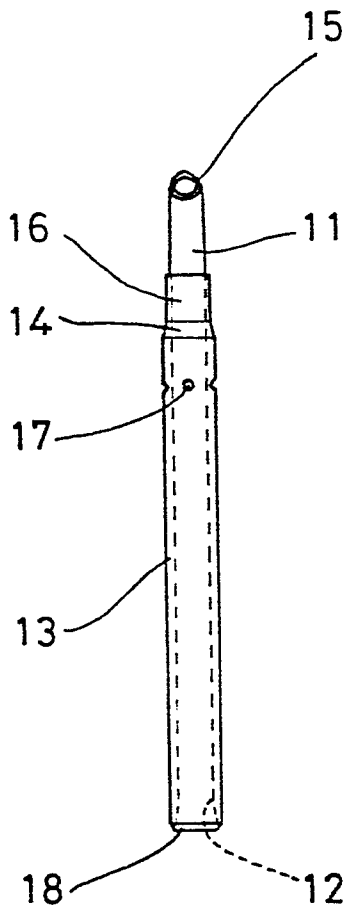

7

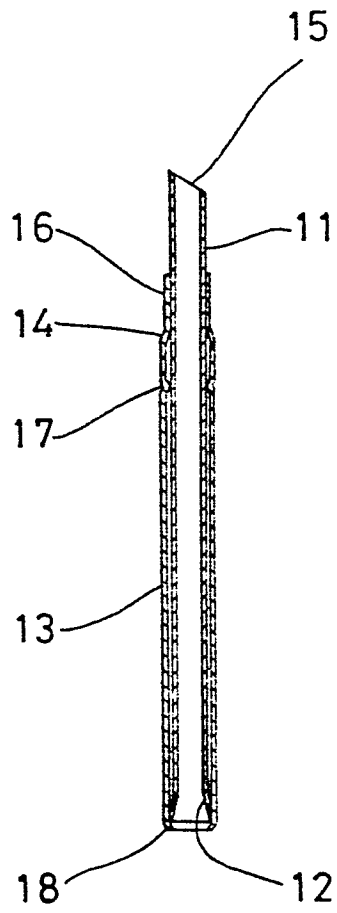

8

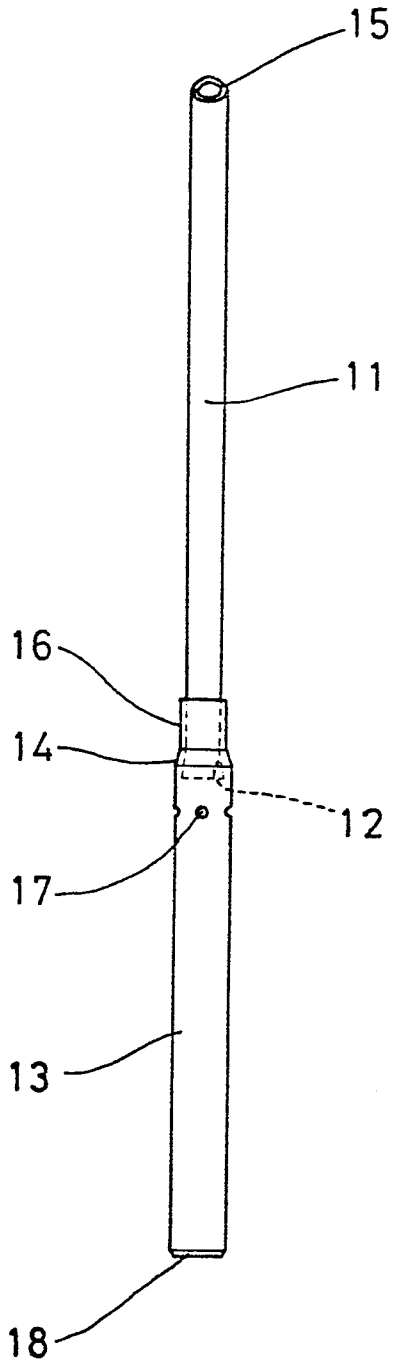

9

