

①②

EUROPEAN PATENT SPECIFICATION

④⑤ Date of publication of patent specification: **08.06.88**

⑤① Int. Cl.⁴: **E 03 D 9/03**

②① Application number: **84307407.1**

②② Date of filing: **26.10.84**

⑤④ **Lavatory cistern dispenser.**

③⑩ Priority: **28.10.83 GB 8328919**

④③ Date of publication of application:
08.05.85 Bulletin 85/19

④⑤ Publication of the grant of the patent:
08.06.88 Bulletin 88/23

⑧④ Designated Contracting States:
AT BE CH DE FR GB IT LI NL SE

⑤⑥ References cited:
FR-A-2 424 374
GB-A-1 219 200
GB-A-2 090 884
GB-A-2 114 623
US-A-4 459 710

⑦③ Proprietor: **UNILEVER PLC**
Unilever House Blackfriars P.O. Box 68
London EC4P 4BQ (GB)

⑧④ **GB**

⑦③ Proprietor: **UNILEVER NV**
Burgemeester s'Jacobplein 1 P.O. Box 760
NL-3000 DK Rotterdam (NL)

⑧④ **BE CH DE FR IT LI NL SE AT**

⑦② Inventor: **Jones, Frank**
Am Ruhberg 9
D-6909 Dielheim (DE)
Inventor: **Kay, Stephen Norman**
22 Beauworth Avenue
Greasby Wirral Merseyside (GB)

⑦④ Representative: **Mole, Peter Geoffrey et al**
UNILEVER PLC Patent Division P.O. Box 68
Unilever House Blackfriars
London EC4P 4BQ (GB)

Note: Within nine months from the publication of the mention of the grant of the European patent, any person may give notice to the European Patent Office of opposition to the European patent granted. Notice of opposition shall be filed in a written reasoned statement. It shall not be deemed to have been filed until the opposition fee has been paid. (Art. 99(1) European patent convention).

EP 0 140 692 B1

Description

This invention relates to a dispenser for partial immersion in a lavatory cistern.

Devices for colouring and perfuming the flush water of lavatories are becoming increasingly popular. They are generally of two types: those which are designed to clip inside the rim of the lavatory bowl itself and those which are intended to be at least partly immersed in the flush water in the cistern. This invention relates to the latter type.

There have been a large number of proposals for making dispensers intended for complete or partial immersion in lavatory cisterns, and some of the problems are now recognised in the art. One major problem is that dispensers having moving parts are unreliable and expensive to manufacture. Another is that modern cisterns are of very low volume and there is consequently very little space available inside them for dispensers. This problem is normally approached by designing the dispenser so that one side is planar and so can lie against the wall of the tank, the other side being formed with the various compartments and pipes which are required for its function. This type of arrangement is shown in GB-A-1 219 200 (Rickitt & Colman).

If it is desired to make the substance dispensed functional rather than merely cosmetic, then it is almost an essential that a chlorine bleach should be present in the dispenser, which introduces the possibility of undesirable chemical interactions between the chlorine-containing component and any cosmetic or cleaning component, as well as with components in the cistern. One of the solutions to interaction of chlorine bleach with cosmetic components such as colorant or perfume or with surfactants in a cleaning component is to separate these components into two compartments. Dispensers of this type having twin compartments so that two different materials can be dispensed simultaneously are described in GB-A-1 219 200 referred to above and also in US-A-3 504 384 (Russell Laboratories). European patent Nos '1671, '4990 and '4991 (Procter & Gamble) also describe dispensers of this type. A further feature which is said to be of importance in the latter patents is that the bleach component is isolated from detergent/dyestuff and from the cistern water until the moment the cistern is flushed. The dispensers required for this are relatively sophisticated in two respects. First of all, they require careful positioning in the cistern, relative to the upper level of flush water. Secondly, they are designed to operate at least partially by means of siphonic action rather than by direct displacement of the solution to be dispensed into the flush water.

GB-A-2090884 describes a dispensing device for dispensing a substance into flush water in a lavatory cistern having a lower chamber holding a water soluble treatment material having an outlet at one end of a conduit extending downwardly from the top of the chamber, and an upper

chamber, a sinuous conduit connecting the bottom of the upper chamber with the top of the lower chamber. This dispenser relies upon air locks when the cistern remains full to prevent mixing between the contents of the upper chamber and the lower chamber and to prevent the contents of the lower chamber passing into the surrounding water.

We have now designed a type of dispenser which avoids the disadvantages referred to above, which operates on a simple displacement principle, which is tolerant to positioning relative to the level of flush water in the cistern, and which is susceptible to simple modification during manufacture to take account of different market requirements.

Accordingly, in a first aspect the present invention provides a dispenser for dispensing one or more substances into flush water in a lavatory cistern comprising

(a) a compartment (14, 24) holding a solid water-soluble or water dispersible substance (16, 29) to be dispensed

(b) at least one aperture (12) in the compartment permitting ingress of water or dilute solution for dissolving the substance and permitting egress of a solution or suspension of the substance.

(c) a reservoir (19) communicating with the compartment, and

(d) means for adjustably locating the dispenser in the cistern, characterised in that the reservoir communicates with the compartment by way of a conduit (18) extending vertically from the bottom of the compartment to the bottom of the reservoir to permit water or solution in the reservoir to drain into the compartment when flush water in the lavatory cistern falls from an upper, storage level to a lower, flushed level.

In one embodiment the dispenser is designed so that the reservoir is provided with an upwardly extending air bleed which, when the dispenser is located in the lavatory cistern, extends above the surface of the flush water.

It will be appreciated that the existence of the vertically extending air bleed allows the dispenser to be positioned with wide tolerance relative to the surface of the flush water in the cistern. This is advantageous since it is our experience that cisterns do not fill consistently to the same level owing to the crude nature of domestic ball valves and to variations in water pressure. Alternatively, the opening of the air bleed may be positioned below the surface if desired.

In one embodiment of the invention, the upper end of the air bleed is sealable, for example with a floating ball which seals a circular aperture of smaller diameter than the ball itself. With this arrangement, and other mechanically equivalent arrangements, the tolerance of the dispenser to vertical positioning within the cistern is retained, but the overall height of the dispenser is reduced, which can be advantageous for small cisterns.

The arrangement of the reservoir upstream of

the compartment holding the substance to be dispensed has the consequence that water in the compartment, which is converted to a solution during the periods between flushes, is displaced by water in the reservoir as the cistern water falls during the flush, and a positive hydrostatic pressure ensures that problems produced by viscous solution in the compartment, or by break-up of the block of substance, are minimised. The volume of the reservoir controls the volume of solution displaced from the dispenser on flushing. If the reservoir volume is smaller than the volume of solution in the compartment, then that ensures that some relatively concentrated solution is always left in the dispenser so that even if the lavatory is flushed and re-flushed in rapid succession, some of the substance in the compartment will always be dispensed.

As is explained later, good control over diffusion of the substances to be dispensed into the cistern water is possible if the aperture to the compartment is at one end of an inverted 'U' shaped conduit, the other end communicating with the bottom of the compartment. In that case, or with any other arrangement, it is preferred that the diameter of the aperture end of the conduit is sufficient to permit air to pass into the compartment while flush water in the cistern is close to its minimum level, to fill the vacuum left in the compartment by partial dissolution of the substance being dispensed. The question of ingress of air is important since unless it is arranged the partial vacuum formed in the substance compartment can assist the block of substance to stick to the walls of the compartment. For that reason it is preferred that the compartment is formed with a vertically extending channel on one or both sides, permitting passage of air into the upper part of the compartment, the substance to be dispensed being presented from contacting the side of the compartment by the formation of defining the edge of the channel.

As has been suggested, there is very little spare space inside a modern cistern. We have found that the best way of using what little space there is to provide a backing sheet which is planar and to form the structure of the dispenser in a formed sheet attached thereto. Accordingly, in a preferred aspect of the invention the compartment(s) and the associated reservoir(s) are formed on the same side of the backing sheet.

It is highly preferred that the dispenser is formed with two compartments with associated reservoirs that is to say that the dispenser is doubled. One compartment can then contain a solid disinfectant block capable of delivering chlorine and the other a detergent cake, a solid colorant or a perfume sorbed on a solid substance, or any combination of these substances. However, given that active chlorine-containing compounds are so chemically reactive careful formulation will be required before organic materials can be combined with them.

The solid disinfectant block may be either cast or formed from granules. Suitable substances for

forming such blocks are calcium hypochlorite or various sodium salts of di- or tri-chlorocyanuric acid.

The water ingress/egress aperture(s) preferably communicate with the compartment(s) via vertically extending conduits, and one of the advantages of the dispenser is that it is possible to pre-determine the extent to which the substances in the compartments diffuse into the flush water in the cistern by choice of length of the conduit. In particular in the case of a doubled dispenser, the compartments of which contain dyestuff and disinfectant, it is possible to ensure that the dyestuff diffuses to a greater extent than the disinfectant by extending the conduit communicating with the disinfectant compartment to a level closer to that defined by the flush water surface than the conduit communicating with the dyestuff compartment. In other words to arrange that there is a greater hydrostatic pressure at the dyestuff aperture than there is at the disinfectant one.

While the dispenser of the invention may be manufactured from any inert, water-impermeable material it is preferred that it is made from a thermoplastic material such as polyvinylchloride or polyethylene. Desirably this can be done by vacuum forming and the attachments between the backing sheet and the formed sheet can be made by thermal or high-frequency welding.

The invention will be further described with reference to the accompanying drawings in which:-

Figure 1 is a front elevation of a double dispenser according to the invention;

Figure 2 is a plan view of the dispenser;

Figures 3, 4 and 5 are front elevations of the dispenser installed in a cistern, respectively with water at the minimum level, at an intermediate level and at a maximum level.

Figure 6 is a front elevation of a single dispenser containing a sealed air bleed.

Figure 7 is a front elevation of another double dispenser according to the invention.

Figure 8 is a front elevation of yet another double dispenser according to the invention.

Figure 9 is a front elevation of further double dispenser according to the invention.

Referring first to Figure 1 the dispenser consists of two sheets of plastics material, a backing sheet (10), not shown, and a formed sheet (11), welded together along their outer edges. The backing sheet (10) is laminar. The formed sheet (11) is formed, for example by vacuum moulding with a number of depressions, channels and apertures which will be described in more detail later, and the edges of each of these features are continuously welded to the backing sheet (10) so as to form a number of compartments and conduits.

From the left-hand side in Figure 1 the formed sheet (11) is formed with a water inlet/outlet aperture (12) which constitutes the end of a vertically extending inlet/outlet conduit (13). The conduit (13) leads to, and communicates with, an opening (15) to a generally rectangular disinfectant

tant block compartment (14) which contains a solid block of a granular, water-soluble chlorine-containing disinfectant (16). The disinfectant block compartment (14) is provided with a second opening (17) at a lower level than opening (15), which communicates with vertically extending reservoir conduit (18). This conduit leads to a reservoir (19) located at a higher level than the disinfectant block compartment, which is a generally rectangular compartment of similar volume to the compartment (14). The reservoir conduit (18) communicates with the reservoir opening (20). The upper face (21) of the reservoir (19) is formed with an opening (22) which communicates with a narrow, vertically extending open-ended capillary air bleed (23).

At this point one half of the apparatus has been described. The other half is a mirror image of the first half and will not be described, except to say that in the place of the disinfectant block compartment (14) containing a disinfectant block (16) there is a detergent block compartment (24) containing a block (25) of granular detergent admixed with a water-soluble or water-dispersible pigment.

Referring now to Figure 2 it can be seen how the compartment and conduits described are formed between the backing sheet (10) and the formed sheet (11), this being the general manner of construction of all the devices shown in figures 1 to 9. In particular, starting from the left-hand side the water inlet/outlet aperture (12) forming the end of inlet/outlet conduit (13) can be seen in plan. The upper face (21) of reservoir (19) partly masks disinfectant block compartment (14), but reservoir conduit (18) is visible. Welds between the backing sheet (10) and the formed sheet (11) are shown.

The operation of the dispenser shown in Figures 1 and 2 will be described with reference to Figures 3, 4 and 5.

Referring to Figure 3, the apparatus is shown in a condition which would subsist immediately after the lavatory has been flushed and the apparatus has been in use for a short period. That is to say the apparatus is not in a new condition. It can be seen that in this condition each pair of inlet/outlet conduits (13), each pair of compartments (14), (24) and each pair of reservoir conduits (18) is filled either with water or with a more or less concentrated solution of disinfectant or of the detergent and dyestuff mixtures. The cistern is at this minimum level for only a short period, as it immediately begins to fill, and as soon as it reaches the level of the water inlet/outlet apertures (12) as shown in Figure 4, it begins to displace the solution already in the apparatus and push it through the system. In fact, fresh water enters the inlet/outlet apertures (12) and displaces the solution originally there into compartment (14) or (24), which in turn displaces solution in the reservoir conduits (18) into the reservoirs (19) and so into the capillary air bleed (23). When the cistern is full, as shown in Figure 5, the level of water/solution inside the apparatus is the same as

that in the cistern, ignoring any capillary effects, since the air bleed (23) is both open to the atmosphere and above the maximum level to which the water rises. The cistern will often remain at this level for some period of time, during which water in compartments (14) and (24), in contact with either a disinfectant block or a detergent/dyestuff block will be converted into a relatively concentrated solution. When the lavatory is flushed, the water level in the cistern will begin to fall, and as it falls from the level shown in Figure 5 to that shown in Figure 4 a volume of solution equivalent to the volume in the air bleeds (23) and in the reservoir (19) will be displaced from compartments (14) and (24) and from inlet/outlet conduits (13). This is a relatively concentrated solution which will mix with the remaining flush water in the cistern as the water level falls further.

Referring now to Figure 6, the dispenser shown is designed to dispense only one substance or a single mixture of substances. As in the embodiments described above, it consists of a planar backing sheet (not shown) and a formed sheet (11) which between them define a compartment (14), a reservoir (19) and associated apertures and pipework. A vertically extending conduit (13), in communication with the bottom of compartment (14), has a side-branch (26) which is returned to the bottom of the dispenser by means of open-ended down-pipe (27).

The right hand lower corner of the compartment (14) as shown in Figure 6 is in communication with reservoir conduit (18) which leads to the lower right hand corner of reservoir (19). The reservoir (19) is formed with a cylindrical air bleed (23) containing a buoyant ball, free to rise and fall within the bleed.

In use, and considering the dispenser in a lavatory cistern in the newly flushed state with the flush water at its minimum level, the water rises in the cistern until it meets aperture (28) of down-pipe (27) which will then fill up to the level of side-branch (26). Water then fills compartment (14) containing a pigmented and perfumed detergent block (29) and rises up reservoir conduit (18). As it rises further it fills reservoir (19) until buoyant ball (30) seals against aperture (31) in the air bleed (23). The dispenser is then full.

During the interval between the cistern filling and being re-flushed the surfactant cake (29) is exposed to water in compartment (14) and a solution containing surfactant, pigment and perfume is formed.

When the lavatory is flushed the flush water in the cistern begins to fall, and as it does so water in reservoir (19) begins to draw into compartment (14), displacing the surfactant solution already in the compartment through conduit (13), down-pipe (27) and aperture (28) into the cistern.

Because buoyant ball (30) seals against aperture (31) in air bleed (23), this dispenser can be totally immersed in the cistern water.

Referring now to Figure 7, there are a number of similarities between the dispenser shown in

this figure and that shown in Figures 1 and 2 which will not be re-described. There are also, however, a large number of differences. The first of these is that although the dispenser is doubled, in that it comprises disinfectant solution and detergent solution dispensing sub-assemblies, these are not mirror images of each other, but of a different design. The detergent solution dispensing sub-assembly (32) is of a similar design to the dispenser shown in Figure 6, except that in place of the air bleed fitted with a ball-valve arrangement, the sub-assembly is provided with a capillary air bleed (23) similar to that of the dispenser shown in Figure 1. Similarly, the disinfectant solution dispensing sub-assembly (33) also differs from the dispenser of Figure 6 in the same way, but has the additional difference that the upper portion (34) of the inlet/outlet conduit (13) is joined with the capillary air bleed (23). The other difference between the device shown in Figure 7 is in the design of the openings (15 and 17) to the disinfectant block compartment (14) and the detergent block compartment (24). In the devices shown in Figures 1 to 6 these openings are of small diameter. In the device shown in Figure 7 the openings are larger, the diameter being great enough to allow air to bubble into the disinfectant and detergent compartments (14) and (24) during dispensing.

The significance of this difference lies in this: in the devices shown in Figures 1 to 6 air cannot enter the bleach or detergent compartments. The result of that is that as the disinfectant block or detergent block dissolves away, it is not replaced by anything and so a partial vacuum is formed sucking successively more and more water into the compartments each time the cistern is flushed until at the end of the life of the device the compartments are completely full. Clearly, where a small amount of solid is contacted by a large volume of water more rapid dissolution will take place which unnecessarily shortens the life of the product. In the device shown in Figure 7, in contrast, the amount of water which enters the compartments is roughly constant, since the volume released on dissolution of disinfectant or detergent cake is taken up by air entering through the specially designed openings (15 and 17). Consequently, dissolution of the solid substance does not accelerate as the device ages.

Referring now to Figure 8 the embodiment of the dispenser shown in this figure is quite similar to that shown in Figure 7, but has been somewhat simplified. The most obvious difference is that whereas in Figure 7 the device is provided with two capillary air bleeds, that shown in Figure 8 has one extended bleed (23) and one fore-shortened one (34).

The second difference between the two dispensers concerns the design and positioning of the water inlet/outlet apertures and conduits. In the dispenser shown in Figure 8, the water inlet/outlet conduit (13) in both halves of the apparatus is in the form of an inverted U, the inlet/outlet apertures (12) being flush with the bottom of the

disinfectant block and detergent block compartments (14) and (24).

Referring now to figure 9 the embodiment shown is generally similar to that shown in figure 8, except that the left hand dispenser is a mirror image of that in figure 8, and except that the upwardly extending capillary air bleed (23) has been removed so that both halves of the double dispenser are mechanically equivalent.

Two features of the double dispenser are shown in figure 9 which are not shown in the other figures. The first of these is a vertically extending retainer (37). This is in the form of an open ended tube formed between the backing sheet (10) and the formed sheet (11), only the latter being visible in figure 9. This retainer is intended to retain the elongated portion of a hanger (not shown) for hanging the double dispenser within a lavatory cistern. The vertical location of the device in the cistern can then be adjusted by sliding the hanger within the retainer (37). This arrangement is one which is adopted by lavatory cistern dispensers of the prior art.

The second feature shown in figure 9 is a detail of a side of compartments (14) and (24). Considering the left hand side wall of the dispensers on the left of the device, the formed sheet (11) is welded to the back sheet (10) along the line of formation (36), leaving a channel (35) between the side wall and the formation communicating at each end with the compartment through which air can freely pass. The purpose of this channel is to ensure that there exists a passage by which air can reach the upper part of the compartment, experience having shown that if the substance to be dispensed occupies the whole width of the lower part of the compartment the block can swell and join within it. A free passage for air helps to prevent this, and in any event reduces the area of contact between the block and the compartment wall.

Similar formations (36) and channels (35) are provided in the other compartment side walls shown in figure 9.

Each of the embodiments described is designed so that modifications can be made simply to the inlet and outlet conduits (13) to produce different dispensing characteristics. For example in the embodiment shown in Figures 1 to 5 shortening of the inlet/outlet conduit (13) of the bleach block compartment (14) can result in disinfectant solution slowly leaking into the cistern. This can be advantageous since according to some schools of thought it is necessary to start with a hygienic cistern before it can truly be claimed that a lavatory is hygienically clean. Such modifications can be simply carried out, since it is anticipated that the dispensers will be vacuum formed from thermoplastics material and consequently simple changes can be made to the mould.

Claims

1. A dispenser for dispensing one or more substances into flush water in a lavatory cistern comprising

(a) a compartment (14, 24) holding a solid water-soluble or water dispersible substance (16, 29) to be dispensed

(b) at least one aperture (12) in the compartment permitting ingress of water or dilute solution for dissolving the substance and permitting egress of a solution or suspension of the substance.

(c) a reservoir (19) communicating with the compartment, and

(d) means for adjustably locating the dispenser in the cistern,

characterised in that the reservoir communicates with the compartment by way of a conduit (18) extending vertically from the bottom of the compartment to the bottom of the reservoir to permit water or solution in the reservoir to drain into the compartment when flush water in the lavatory cistern falls from an upper, storage level to a lower, flushed level.

2. A dispenser according to Claim 1 characterised in that the reservoir is provided with an upwardly extending air bleed (23).

3. A dispenser according to any one of the preceding claims characterised in that the aperture (12) in the compartment is at one end of an inverted 'U' shaped conduit (B) the other end communicating with the bottom of the compartment.

4. A dispenser according to any one of the preceding claims characterised in that the diameter of the aperture of the 'U' shaped conduit is sufficient to permit air to pass into the compartment while flush water in the cistern is close to its minimum level, to fill the vacuum left in the compartment by partial dissolution of the substance being dispensed.

5. A dispenser according to Claim 4 characterised in that the compartment is formed with a vertically extending channel (35) on one side, permitting passage of air, the substance to be dispensed being prevented from contacting the side of the compartment by the formation (36) defining the edge of the channel.

6. A dispenser according to Claim 5 characterised in that compartment is formed with a vertically extending channel on both sides.

7. A dispenser according to any one of the preceding claims characterised in that the substance to be dispensed comprises a disinfectant.

8. A dispenser according to any one of Claims 1 to 7 characterised in that the substance to be dispensed comprises a colourant or a perfume.

9. A double dispenser characterised in that it comprises a pair of dispensers in accordance with Claim 1, one containing a disinfectant and the other a detergent, a colourant, a perfume or any of these materials in combination.

Patentansprüche

1. Abgabevorrichtung zur Abgabe einer oder mehrerer Substanzen in das Spülwasser in einem Klosettspülkasten umfassend

(a) ein Abteil (14, 24), welches eine abzugebende feste wasserlösliche oder wasserdispergierbare

Substanz (16, 29) enthält,

(b) mindestens eine Öffnung (12) in dem Abteil, welche den Eintritt von Wasser oder Verdünnungslösung zum Auflösen der Substanz zuläßt und welche den Austritt einer Lösung oder Suspension der Substanz zuläßt,

(c) einen Speicher (19), der mit dem Abteil kommuniziert, und

(d) Einrichtungen zur verstellbaren Fixierung der Abgabevorrichtung in dem Spülkasten,

dadurch gekennzeichnet, daß der Speicher mit dem Abteil über einen Kanal (18), der sich vertikal vom Boden des Abteils zum Boden des Speichers erstreckt, in Verbindung steht, um zuzulassen, daß sich Wasser oder Lösung im Speicher in das Abteil hinein entleert wenn Spülwasser in dem Klosettspülkasten von einem oberen Speicherniveau auf ein unteres, gespültes Niveau fällt.

2. Abgabevorrichtung nach Anspruch 1, dadurch gekennzeichnet, daß der Speicher mit einer sich nach oben erstreckenden Entlüftung (23) ausgestattet ist.

3. Abgabevorrichtung nach einem der vorhergehenden Ansprüche, dadurch gekennzeichnet, daß sich die Öffnung (12) in dem Abteil an einem Ende eines umgekehrten "U"-förmigen Kanals (B) befindet und das andere Ende mit dem Boden des Abteils in Verbindung steht.

4. Abgabevorrichtung nach einem der vorhergehenden Ansprüche, dadurch gekennzeichnet, daß der Durchmesser der Öffnung des "U"-förmigen Kanals ausreichend ist um zuzulassen, daß Luft in das Abteil strömt, während Spülwasser in dem Spülkasten nahe an seinem Mindestniveau ist, um das Vakuum, welches in dem Abteil durch teilweise Auflösung der abzugebenden Substanz übrig bleibt, zu füllen.

5. Abgabevorrichtung nach Anspruch 4, dadurch gekennzeichnet, daß das Abteil mit einem sich vertikal erstreckendem Kanal (35) auf einer Seite gestaltet ist, der die Einleitung von Luft zuläßt, wobei die abzugebende Substanz durch die den Rand des Kanals definierende Gestaltung (36) gehindert ist die Seite des Abteils zu berühren.

6. Abgabevorrichtung nach Anspruch 5, dadurch gekennzeichnet, daß das Abteil mit einem sich vertikal erstreckenden Kanal auf beiden Seiten gestaltet ist.

7. Abgabevorrichtung nach einem der vorhergehenden Ansprüche, dadurch gekennzeichnet, daß die abzugebende Substanz ein Desinfektionsmittel enthält.

8. Abgabevorrichtung nach einem der Ansprüche 1 bis 7, dadurch gekennzeichnet, daß die abzugebende Substanz ein Färbemittel oder ein Parfüm enthält.

9. Doppelte Abgabevorrichtung, dadurch gekennzeichnet, daß sie ein paar Abgabevorrichtungen nach Anspruch 1 umfaßt, wobei eine ein Desinfektionsmittel und die andere ein Detergens, ein Färbemittel, ein Parfüm oder irgendeines dieser Materialien in Kombination enthält.

5

10

15

20

25

30

35

40

45

50

55

60

65

Revendications

1. Distributeur pour distribuer une ou plusieurs substances dans l'eau de chasse d'une retenue d'eau de chasse d'un water-closet comportant

(a) un compartiment (14, 24) contenant une substance solide (16, 29) qui peut se dissoudre ou se disperser dans l'eau et qui doit être distribuée,

(b) au moins une ouverture (12) dans le compartiment permettant l'entrée d'eau ou d'une solution diluée pour dissoudre la substance et permettant la sortie d'une solution ou d'une suspension de la substance,

(c) un réservoir (19) communiquant avec le compartiment, et

(d) un moyen pour placer, avec possibilité de réglage, le distributeur dans la retenue d'eau de chasse,

caractérisé en ce que le réservoir communique avec le compartiment par un conduit (18) qui s'étend verticalement depuis le fond du compartiment jusqu'au fond du réservoir pour permettre à l'eau ou à la solution qui se trouve dans le réservoir de passer dans le compartiment lorsque l'eau de chasse qui se trouve dans la retenue d'eau de chasse du water-closet tombe d'un niveau supérieur d'accumulation à un niveau inférieur, après chasse.

2. Distributeur selon la revendication 1, caractérisé en ce que le réservoir présente un purgeur (23) d'air s'étendant vers le haut.

3. Distributeur selon l'une quelconque des revendications précédentes, caractérisé en ce que l'ouverture (12) prévue dans le compartiment se trouve à l'une des extrémités d'un conduit (13) en

forme de U renversé dont l'autre extrémité communique avec le fond du compartiment.

4. Distributeur selon l'une quelconque des revendications précédentes, caractérisé en ce que le diamètre de l'ouverture du conduit en forme de U est suffisant pour permettre à l'air de passer dans le compartiment pendant que l'eau de chasse qui se trouve dans la retenue est proche de son niveau minimal, pour remplir le vide laissé dans le compartiment par la dissolution partielle de la substance en cours de distribution.

5. Distributeur selon la revendication 4, caractérisé en ce que le compartiment est conformé d'un côté avec un canal (35) qui s'étend verticalement et permet le passage de l'air, la substance à distribuer étant empêchée de venir au contact du côté du compartiment par la conformation (36) qui définit le bord du canal.

6. Distributeur selon la revendication 5, caractérisé en ce que le compartiment est conformé avec un canal s'étendant verticalement de chaque côté.

7. Distributeur selon l'une quelconque des revendications précédentes, caractérisé en ce que la substance à distribuer comprend un désinfectant.

8. Distributeur selon l'une quelconque des revendications 1 à 7, caractérisé en ce que la substance à distribuer comprend un colorant ou un parfum.

9. Distributeur double caractérisé en ce qu'il comporte une paire de distributeurs conformes à la revendication 1, l'un contenant un désinfectant et l'autre un détergent, un colorant, un parfum ou l'un quelconque de ces produits en combinaison.

40

45

50

55

60

65

7

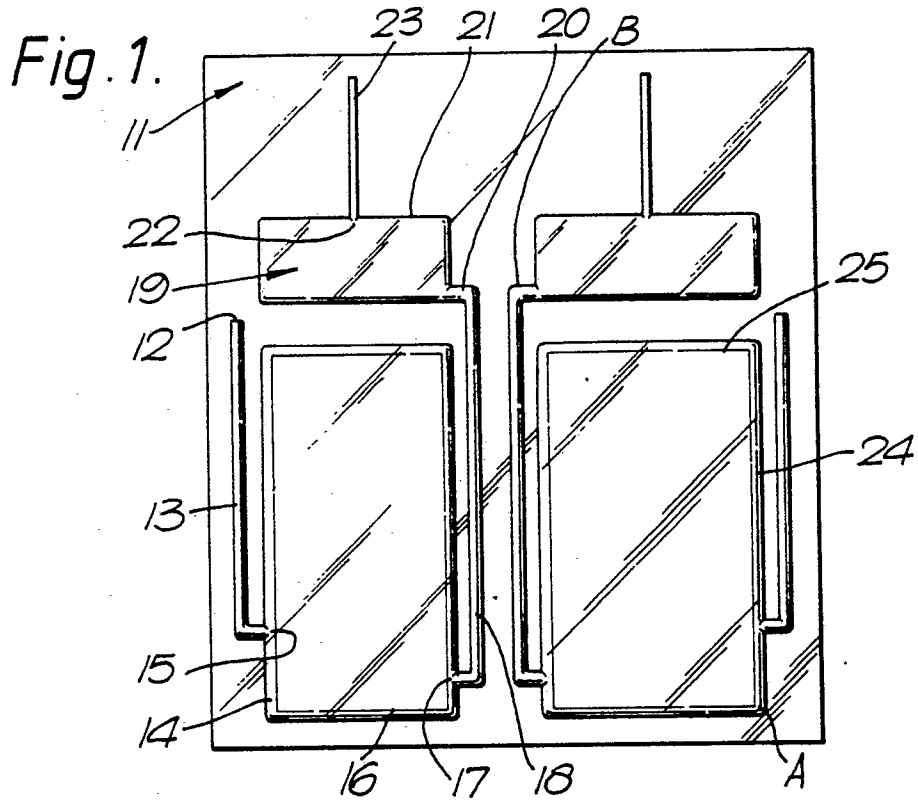

Fig. 2.

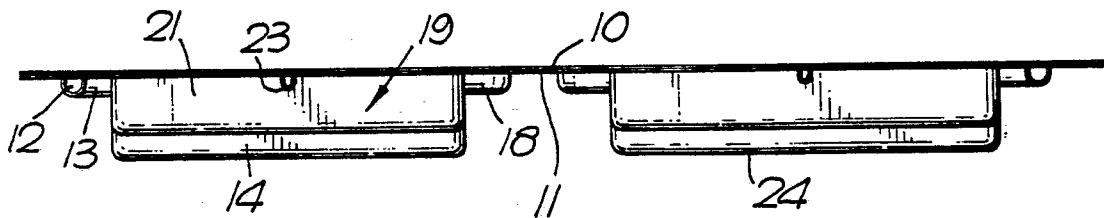

Fig. 3.

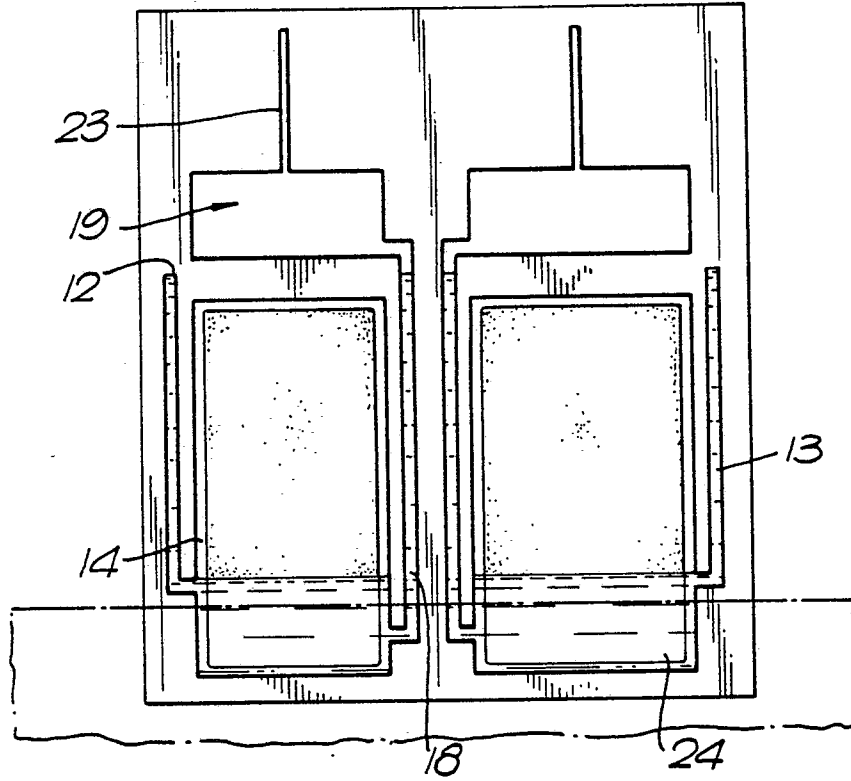

Fig. 4.

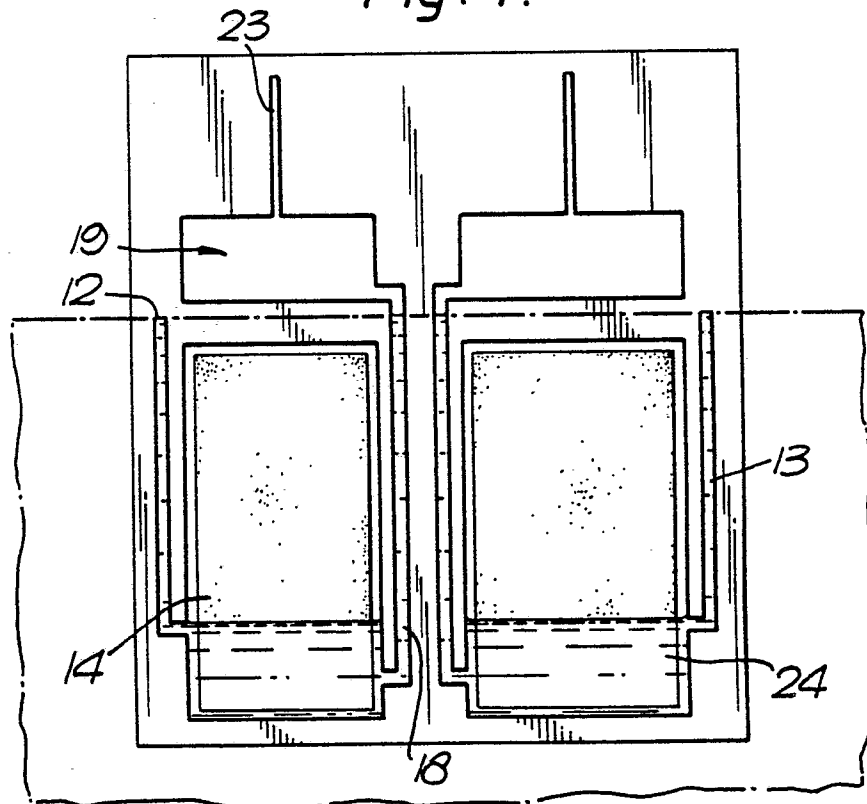

Fig. 5.

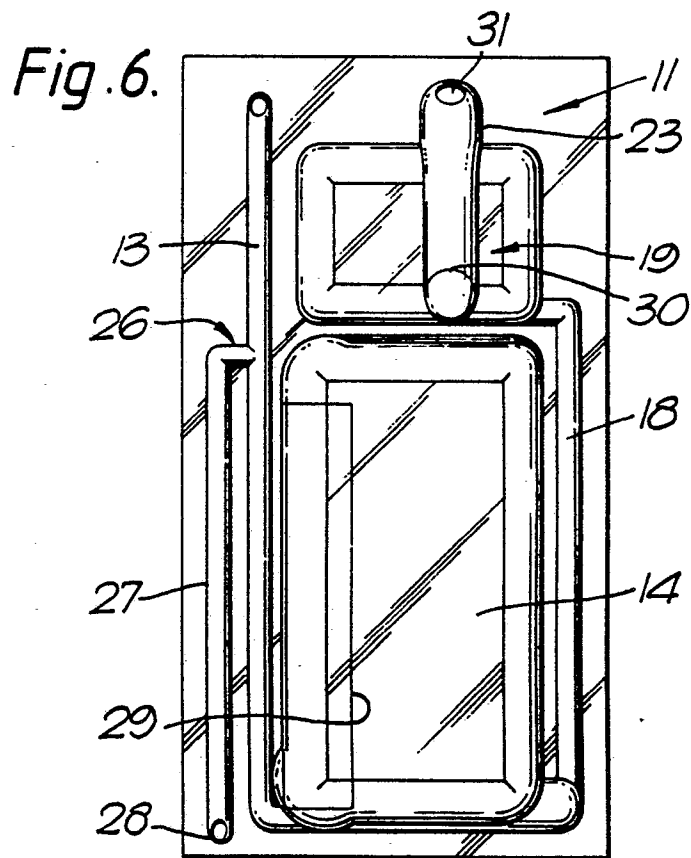
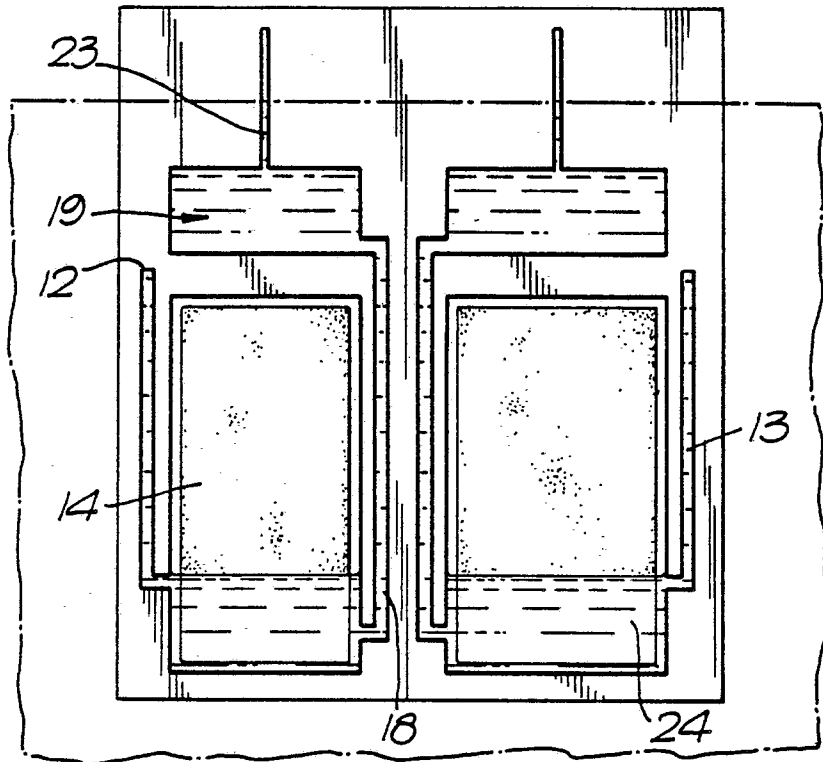

Fig. 7.

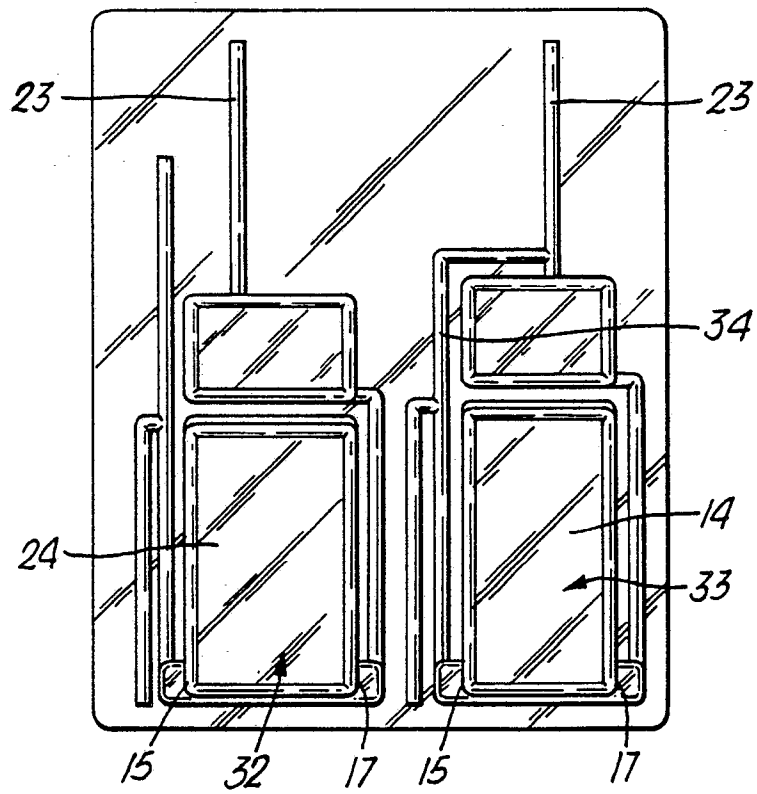

Fig. 8.

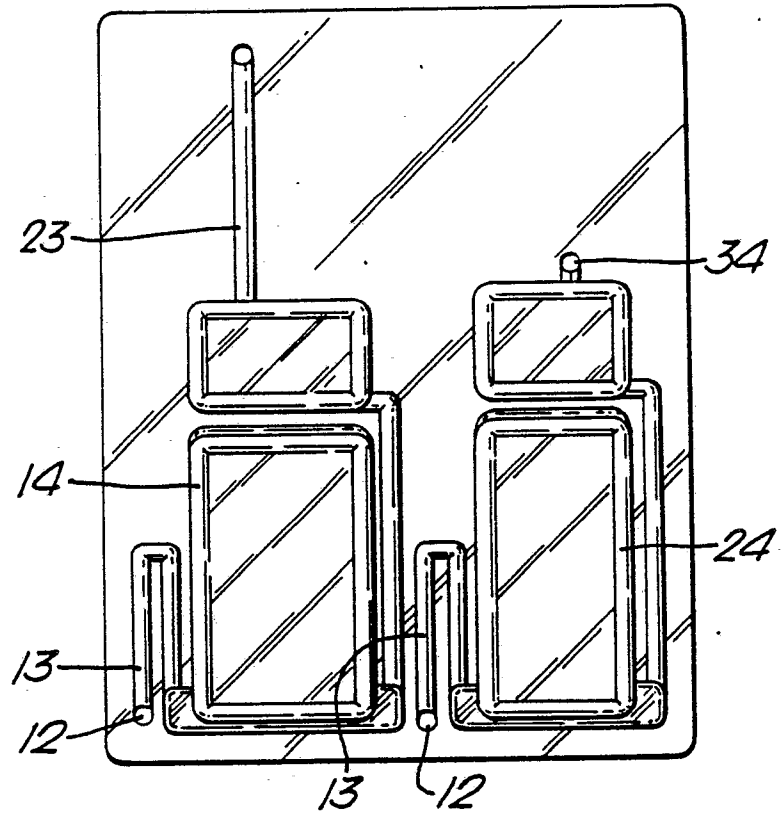

Fig. 9.

