

12 **EUROPEAN PATENT APPLICATION**

21 Application number: 85630049.6

51 Int. Cl. **E 21 B 19/16, E 21 B 19/02,**
E 21 B 3/02

22 Date of filing: 04.04.85

30 Priority 16.04.84 US 600913

71 Applicant: **HUGHES TOOL COMPANY, 5425 Polk Avenue, Houston Texas 77023 (US)**

43 Date of publication of application: 21.11.85
Bulletin 85/47

72 Inventor: **Hamilton, William Roger, 811 Shady Hollow Drive, Georgetown Texas 78626 (US)**

34 Designated Contracting States: **DE FR GB**

74 Representative: **Waxweiler, Jean et al, OFFICE DENNEMEYER S.à.r.l. 21-25 Allée Scheffer P.O.Box 41, L-2010 Luxembourg (LU)**

54 **Top drive well drilling apparatus with removable link adapter.**

57 A well drilling apparatus having a drive unit for rotating a drill string (27). A stem (25) extends downward from the drive unit, and during tripping a link adapter (35) is removably connected to the stem (25). During tripping, an elevator (31) is suspended from the link adapter (35) by a pair of links (33), and the drill string (27) is held by the elevator (31).

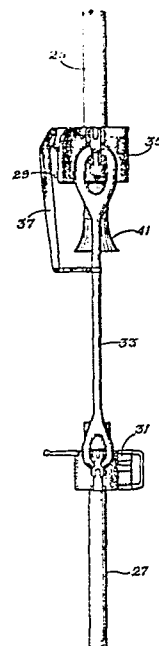

EP 0 162 000 A1

This invention relates in general to a well drilling apparatus and in particular to a top drive well drilling apparatus.

5 A top drive drilling system rotates a drill string from the top, rather than using a rotary table, a kelly, and a kelly bushing. An electric drilling motor is suspended from the drilling rig's conventional swivel and is attached to the top of the drilling string. The
10 drilling motor may also be attached to a carriage, which is guided by a pair of vertical tracks. The drilling motor is connected to the drill string by a cylindrical stem, which extends downward from the motor. A wrench assembly is also suspended from the drilling motor, in order to
15 brack out or make up connections between the stem and the drill string. A link adapter, on the stem, supports a pair of links, which in turn support an elevator below the bottom of the stem. As the drill string is drilled down, the elevator will contact the floor of the drilling rig.
20 If the elevator and the wrench assembly could be moved out of the way, the drill string could be drilled down further before additional lengths of pipe must be added to the drill string.

The present invention is a top drive well
25 drilling apparatus in which the link adapter is removable from the stem, so that link adapter, links, and elevator may be removed from the stem during drilling. The link adapter and the stem have alignment means for aligning the link adapter on the stem, and a downward facing shoulder
30 on the link adapter engages an upward facing shoulder on the stem. The link adapter also has means for stabilizing the links and for tilting the links to a non-vertical position.

The above, as well as additional objects, features, and advantages of the invention, will become
35 apparent in the following detailed description of the invention which is shown by way of example in the attached drawings, wherein:

Figure 1 is a perspective view of a drilling

apparatus during a drilling operation;

Figure 2 is a side view of a link adapter, and an elevator during a tripping operation;

5 Figure 3 is a top view of a link adapter ; and
Figure 4 is a side view of a link adapter.

Figure 1 illustrates a top drive well drilling apparatus of the invention. A conventional traveling block 13 and a conventional hook 15 are suspended by
10 cables 17 from the top of an oil well derrick. A drive unit 19 is suspended from the hook 15 and mounted on a carriage 21. The drive unit 19 is a drilling motor of a conventional type. The carriage 21 guides the drive
15 unit 19 up and down along a pair of vertical guide tracks 23. A cylindrical quill, or stem 25, extends downward from the drive unit 19, and connects to the top of a drill string 27. The drill string 27 consists of a series of pipe sections and has a rotary rock bit attached at the bottom for drilling a well bore.

20 A wrench assembly 29 is provided for making up the connection between the stem 25 and the drill string 27. The wrench assembly is mounted to the carriage 21, and is capable of moving between a working position along the stem 25, or the axis of the drill string 27,
25 and a retracted position away from the axis of the drill string 27. The wrench assembly 29 is also capable of moving vertically along the stem 25 and the drill string 27.

Figure 2 illustrates a portion of the top
30 drive well drilling apparatus during a tripping operation. The drill string 27 is not connected directly to the stem 25, but is suspended from a conventional pipe elevator 31. The elevator 31 is suspended from a pair of links 33 which depend from a link adapter 35.
35 A link stabilizer 37 is connected between the link adapter 35 and the links 33. The link stabilizer 37 stabilizes the links 33 and, in cooperation with a hydraulic cylinder 39, may also be used to tilt the links 33 to

a non-vertical position. The link stabilizer 37 is thus a stabilizing means for stabilizing the links 33, and is also a tilting means for tilting the links 33 to a non-vertical position. A bell 41 is attached to the lower end of the stem 25 to facilitate makeup between the drill string 27 and the stem 25, if the drill string 27 and the stem 25 have to be reconnected while the link adapter 35 is still in place.

10 Figures 3 and 4 are close-up views of the removable link adapter 35. The link adapter 35 has a central bore 43, adapted to receive the stem 25. The link adapter 35 has a door 45, which can be opened to allow the link adapter 35 to be placed around the stem 15 25. Once the link adapter 35 has been positioned on the stem 25, the door 45 may be secured with the pins 47. The door 45 is adapted to engage an alignment dog 49 (shown in Fig. 1) on the stem 25. The door 45 and the alignment dog 49 are thus an alignment means for 20 aligning the link adapter 35 on the stem 25. The bore 43 of the link adapter 35 has a downward facing shoulder 51, which is adapted to engage an upward facing shoulder 53 (shown in Fig. 1) on the stem.

In operation, the well drilling apparatus 25 is in the configuration shown in Fig. 1 during the drilling of a well bore. However, there are times when drilling must be stopped and the drill string 27 must be removed from the well bore. For example, the drill string 27 must be removed from the well bore occasionally 30 in order to replace a worn drill bit. The process of removing the drill string 27 from the well bore, and then reinserting the drill string 27 back into the well bore, is known as a tripping operation. During a tripping operation the drill string 27 is not connected 35 directly to the stem 25, but is suspended from a pipe elevator 41, as shown in Fig. 2.

In order to change from the drilling configuration (Fig. 1) to the tripping configuration (Fig. 2),

slips in the floor of the drilling rig are first set to hold the weight of the drill string 27. The wrench assembly 29 is then used to break out the connection
5 between the drill string 27 and the stem 25. The stem 25 is then raised to separate the stem 25 from the drill string 27. The removable link adapter 35 is then placed around the stem 25, so that the downward facing shoulder 51 of the link adapter 35 engages the upward
10 facing shoulder 53 on the stem 25. The alignment dog 49 insures that the link adapter 35 is properly aligned on the stem 25. The door 45 of the link adapter 35 is then closed and secured with pins 47. The conventional elevator 31 is now suspended below the link adapter 35
15 by the links 33. The elevator 31 is then connected to the drill string 27 in a conventional manner.

In order to return to the drilling configuration, the steps explained above are merely reversed. The slips in the floor of the drilling rig are set to hold
20 the drill string 27. Then the elevator 31 is removed from the drill string 27, and the link adapter 35 is removed from the stem 25. The stem 25 is then lowered to the drill string 27, and the wrench assembly 29 is used to make up the connection.

25 If, for some reason, it becomes necessary to reconnect the drill string 27 to the stem 25 while the link adapter 45 is in place, the drill string 27 may be set in the slips while the stem 25 is lowered onto the drill string 27. The bell 41 on the stem 25 will guide
30 the drill string 27 to make a proper engagement.

The top drive well drilling apparatus of the invention has several significant advantages over the prior art. Since the links 33 and the elevator 31 do not hang
35 down below the stem 25 during drilling, the drill string 27 can be drilled down further before additional lengths of pipe have to be added to the drill string. The invention also allows servicing or replacement of the link adapter 35, the links 33, and the elevator 31, without

interrupting drilling.

While the invention has been shown in only one of its forms, it should be apparent to those skilled in the art that it is not so limited, but is susceptible to various changes and modifications without departing from the spirit thereof.

CLAIMS :

1. A well drilling apparatus, comprising :
a drive unit (19), for rotating a drill
5 string (27) about the longitudinal axis of the drill
string; and
a stem (25) extending downward from the drive
unit (19) , to which the drill string (27) may be
removably connected, for transmitting torque from the
10 drive unit to the drill string; characterized by
a link adapter (35), removably connected to the
stem (25), so that the link adapter may be removed
from the stem during drilling;
a pair of elevator links (33) suspended from
15 the link adapter (35) and
an elevator (31) suspended from the elevator
links (33) for suspending the drill string (27) during
tripping.
2. A well drilling apparatus according to claim 1,
20 characterized by alignment means (45,49) for aligning
the link adapter (35) on the stem (25).
3. A well drilling apparatus , according to
claim 1 or 2, characterized in that said stem (25)
has an upward facing shoulder (53) and that said link
25 adapter (35) has a downward facing shoulder (51) for
engagement with the shoulder (53) on the stem (25).
4. A well drilling apparatus according to anyone
of the claims 1 to 3, characterized by an elevator,
suspended from the elevator links, for stabilizing
30 means (37) for stabilizing the links (33).
5. A well drilling apparatus according to anyone
of the claims 1 to 4 characterized by tilting means
(29,37) for tilting the links (33) to a non-vertical
position.

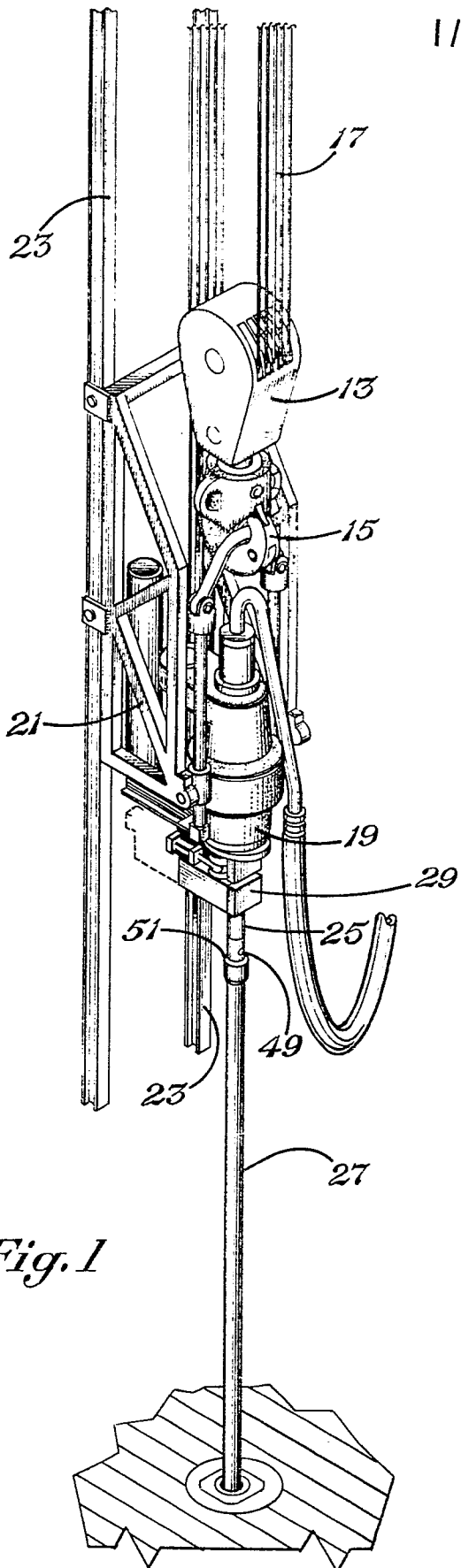

Fig. 1

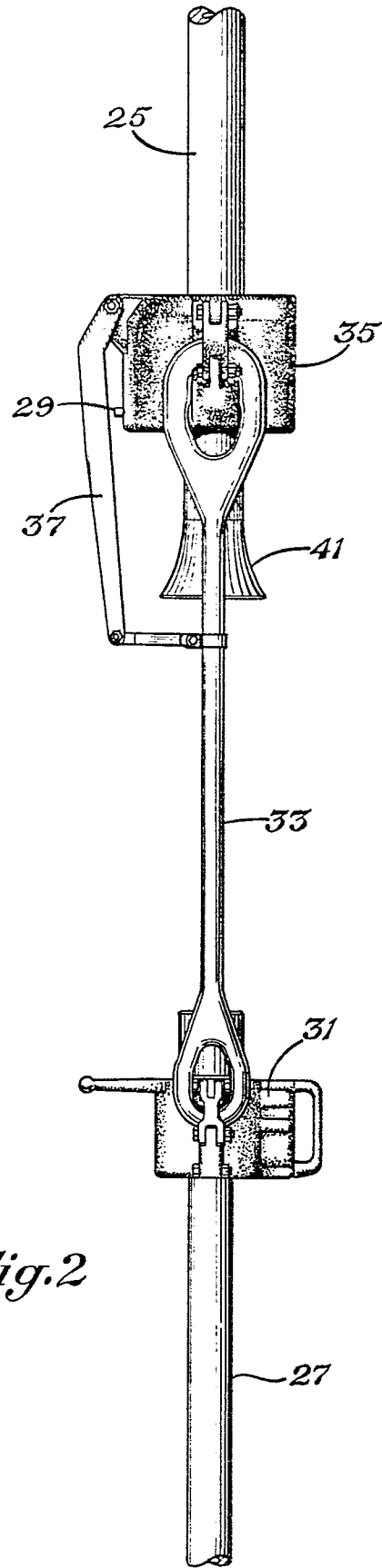

Fig. 2

2/2

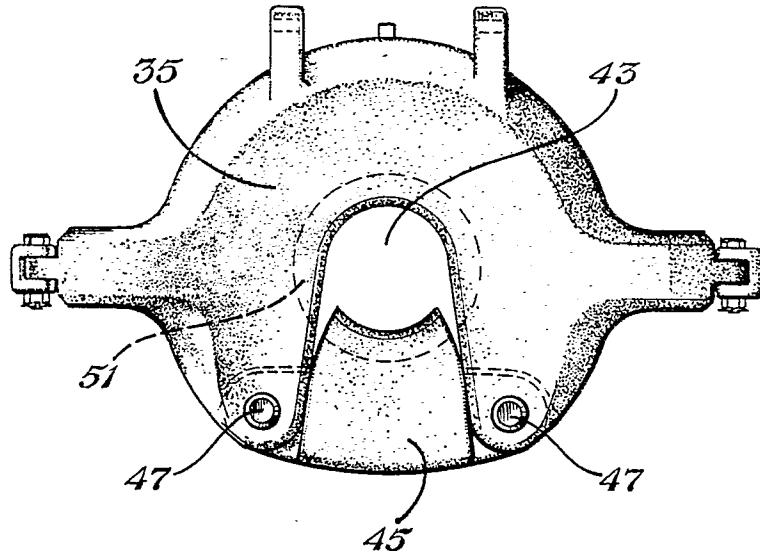

Fig. 3

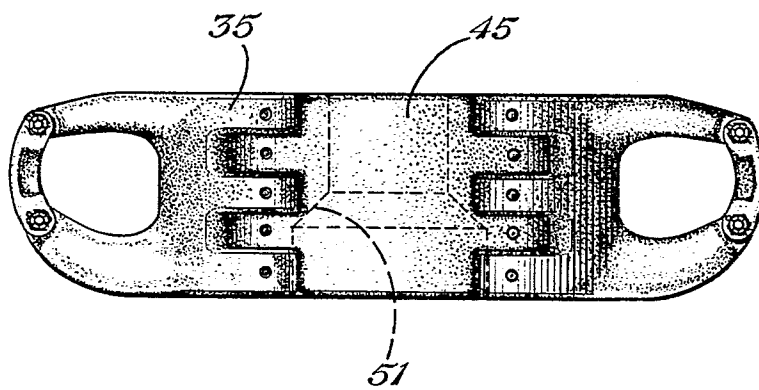

Fig. 4



DOCUMENTS CONSIDERED TO BE RELEVANT			
Category	Citation of document with indication, where appropriate, of relevant passages	Relevant to claim	CLASSIFICATION OF THE APPLICATION (Int. Cl. 4)
X	US-A-3 915 244 (BROWN) * Column 3, lines 32-47 *	1, 4, 5	E 21 B 19/16 E 21 B 19/02 E 21 B 3/02
X	--- US-A-4 209 066 (WATSON) * Column 4, lines 33-36; column 1, line 55 - column 4, line 12 *	1	
X	--- US-A-3 776 320 (BROWN) * Column 3, lines 36-45; column 4, lines 12-18 *	1	
X	--- FR-A-2 146 954 (HOURCADE) * Page 4, lines 17-22 *	1	
A	--- US-A-3 857 450 (GUIER) * Claim 1 *	1, 4, 5	
A	--- US-A-1 967 517 (ROGERS) * Column 2, lines 39-88 *	1, 3	
A	--- US-A-4 396 216 (HAMILTON) * Abstract *	1-3	

The present search report has been drawn up for all claims			
Place of search THE HAGUE		Date of completion of the search 26-07-1985	Examiner SOGNO M. G.
CATEGORY OF CITED DOCUMENTS		T : theory or principle underlying the invention E : earlier patent document, but published on, or after the filing date D : document cited in the application L : document cited for other reasons & : member of the same patent family, corresponding document	
X : particularly relevant if taken alone Y : particularly relevant if combined with another document of the same category A : technological background O : non-written disclosure P : intermediate document			