

**EUROPEAN PATENT SPECIFICATION**

- (45) Date of publication of patent specification: **10.10.90**      (51) Int. Cl.<sup>5</sup>: **E 04 B 1/32, E 04 C 3/02**  
(71) Application number: **85304855.1**  
(22) Date of filing: **08.07.85**

(54) **Architectural arch.**

(30) Priority: **09.07.84 GB 8417451**

(43) Date of publication of application:  
**15.01.86 Bulletin 86/03**

(45) Publication of the grant of the patent:  
**10.10.90 Bulletin 90/41**

(84) Designated Contracting States:  
**AT BE CH DE FR IT LI LU NL SE**

(56) References cited:  
**CH-A- 163 793**  
**GB-A- 561 070**  
**US-A-3 672 110**

(78) Proprietor: **Knox, Colin James Michael**  
**Southbrook House**  
**Bovey Tracey, Devon TQ13 9NB (GB)**

(72) Inventor: **Knox, Colin James Michael**  
**Southbrook House**  
**Bovey Tracey, Devon TQ13 9NB (GB)**

(7A) Representative: **Rees, David Christopher et al**  
**Kilburn & Strode 30 John Street**  
**London WC1N 2DD (GB)**

Note: Within nine months from the publication of the mention of the grant of the European patent, any person may give notice to the European Patent Office of opposition to the European patent granted. Notice of opposition shall be filed in a written reasoned statement. It shall not be deemed to have been filed until the opposition fee has been paid. (Art. 99(1) European patent convention).

## Description

The present invention relates to arches for use in buildings, in particular, brickwork arches. Such arches may be suitable for location over architectural features as windows, doors panels etc., and may have various shapes from flat to semi-circular, gothic and many other decorative forms.

In the past, arches have been made by various methods. In perhaps their simplest form, arches have comprised a series of upright or "soldier" bricks arranged side-by-side over the feature and supported either by a lintel beneath or by a rod passing through the bricks from one end of the arch to the other. This would constitute a flat arch. This basic design might be varied by using suitably tapered bricks to arrive at a trapezium-shaped arch having a flat top and bottom.

Other forms of arch are curved, for example, semi-circular arches. These use tapered bricks arranged in a semi-circle above the feature. Thus, they cannot use a rod passing down the centre of the bricks for support nor a semi-circular lintel, however, the semi-circular configuration is a good load bearing/ distributing structure in itself. Nevertheless, these arches require expensive timber formers for their construction and either infill panels beneath them, or correspondingly curved window sections or even further brickwork.

When an arch is required having a form which is neither flat nor semi-circular, problems may arise from a load-bearing point of view. For example, a shallow curved arch suffers all the drawbacks of a semi-circular arch but in addition, has very poor load-bearing characteristics, and so metal angle supports from above may be required, and these are very cumbersome.

It is therefore an object of the present invention to provide a system for an architectural arch which can give a curved appearance while having the constructional advantages and characteristics of a flat arch.

GB-A-561070 shows a form of brick in which one of the faces is inclined relative to the opposite face, for constructional reasons. It is not concerned with the formation of arches possessing any aesthetic qualities.

According to the invention, there is provided an arch comprising a series of bricks laid side by side as a horizontal arch course, characterised in that at least some of the bricks have a cut away portion facing forwards over part of their surface to define a pattern along the length of the course.

The bricks may be of any suitable material and are generally cuboidal, apart from the cutaway portion. The cutaway portions preferably extend into the under surfaces of the bricks and preferably progressively increase in size towards the middle of the arch, thereby defining a curved or gothic arch shape. The pattern preferably extends along the entire length of the arch course thereby spanning the feature beneath the arch.

Thus, the arch construction in accordance with the invention enables an appearance to be given,

or a curved arch since the cutaway portions will be in shadow and will be set back from the facing surface of the arch, while still having the constructional advantages of a flat arch. Furthermore, the inside surfaces exposed in the cutaway portions may be naturally darker if flash" bricks are used.

Preferably, the arch course is laid on a standard lintel support spanning the feature over which the arch extends. In such a case, the cutaway portion may extend back as far or almost as far as the lintel at the greatest extent of the cutaway.

Alternatively, the bricks forming the arch may be supported by a rod passing through them along the length of the course.

Clearly, the pattern defined by the cutaway portions can be increased in size by using larger bricks.

The entire arch may be highlighted in the building by setting the arch course forward of the plane of the wall.

The invention also extends to a set of bricks for forming such an arch, i.e. a set of bricks having cutaway portions which together progressively define a desired pattern such as a curved arch shape.

The invention may be particularly effective when hand thrown bricks are used.

The invention may be carried into practice in various ways and some embodiments will now be described by way of example with reference to the accompanying drawings in which:-

Figure 1 is a perspective view of an arch in accordance with the invention;

Figure 2 is a front view of the arch of Figure 1 in place above a window;

Figures 3, 4 and 5 are vertical sections to a larger scale through selected bricks shown in Figure 2; and

Figures 6, 7, 8 and 9 show various designs of arch which are possible in accordance with the invention.

As shown in Figures 1 and 2 an arch 11 comprises a series of bricks 12 (sixteen in the present embodiment) laid on a lintel 14 spanning a window 15. Each brick 12 has a cutaway 13 in the front face extending back to the under surface. Without the cutaways, the bricks are 215mm high, 140mm deep and 65mm wide, though, of course, other sizes could be used. The cutaways 13 all extend back 48mm but their vertical extents are graduated from zero at the extreme outer edge of the outermost bricks 12 to 112mm at the inner edges of the centre bricks 12. The gradation of the cutaways 13 is such that they form a smooth shallow curved arch shape.

In order to illustrate the form and gradation of the cutaways 13 more clearly, three bricks 12 indicated by the letters A, B and C in Figure 2 are shown in section in Figures 3, 4 and 5 respectively. In brick A, an outermost brick, the maximum height of the cutaway 13 is 25mm (at the right hand side); in brick B, an intermediate brick, the maximum height of the cutaway is 80mm, and in brick C, a centre brick, the maximum height of the cutaway is 112mm. It will be clear that the

height of the cutaway 13 in each brick 12 increases across the brick.

Figures 6, 7, 8 and 9 show various arch configurations which are possible in accordance with the invention. Figure 6 show a deeper curve formed by the cutaways; Figure 7 corresponds to the shape of Figures 1 and 2; Figure 8 shows a shallower curve, and Figure 9 shows a gothic arch design. Naturally, many other designs would be eminently possible. However, in all cases, the significant point is that the bricks are arranged horizontally with the result that a simple lintel or rod can be used for support. This results in an inexpensive and simple system which requires no special skills, in assembly, no special support members, no special formers, and no infill panels or non-standard window shapes.

### Claims

1. An arch comprising a series of bricks laid side by side as a horizontal arch course (11), characterised in that at least some of the bricks (12) have a cut away portion (13) facing forwards over part of their surface to define a pattern along the length of the course.

2. An arch as claimed in Claim 1, characterised in that the bricks (12) are generally cuboidal apart from the cut away portion (13).

3. An arch as claimed in Claim 1 or Claim 2, characterised in that the cut away portions (13) extends into the under surfaces of the bricks (12) and progressively increase in size towards the middle of the arch (11).

4. An arch as claimed in any preceding claim, characterised in that the pattern extends along the entire length of the arch course thereby spanning the feature (15) beneath the arch (11).

5. An arch as claimed in any preceding claim, characterised in that the cut away portions (13) are different in colour to the remainder of the bricks (12).

6. An arch as claimed in any preceding claim, characterised in that the arch course (11) is laid on a standard lintel support (14) spanning the feature (15) over which the arch extends.

7. An arch as claimed in any of Claims 1 to 5, characterised in that the bricks (12) forming the arch are supported by a rod passing through the bricks (12) along the length of the course.

8. A set of bricks for forming an arch, characterised in that the bricks (12) have cut away portions (13) which together progressively define a desired pattern such as a curved arch shape.

### Patentansprüche

1. Ein Bogen, welcher aus einer Reihe nebeneinanderliegender Ziegel besteht, so daß sich ein horizontaler Bogenverlauf (11) ergibt, dadurch gekennzeichnet, daß zumindest einige der Ziegel (12) sich durch Abschneiden ergebende Oberflächenabschnitte (13) aufweisen, welche sich über einen Teil der Ziegeloberfläche erstrecken und

nach vorne gerichtet sind, so daß über die Länge des Bogens ein Muster definiert wird.

2. Ein Bogen gemäß Anspruch 1, dadurch gekennzeichnet, daß die Ziegel (12) bis auf den durch Abschneiden gebildeten Oberflächenabschnitt (13) im allgemeinen quaderförmig sind.

3. Ein Bogen gemäß Anspruch 1 oder 2, dadurch gekennzeichnet, daß die durch Abschneiden gebildeten Oberflächenabschnitte (13) sich bis zu den unten liegenden Flächen der Ziegel (12) erstrecken und sich gegen die Mitte des Bogens (11) zu allmählich vergrößern.

4. Ein Bogen gemäß einem der vorhergehenden Ansprüche, dadurch gekennzeichnet, daß sich das Muster über die gesamte Länge des Bogenverlaufs erstreckt und somit den Bauteil (15), der unter dem Bogen (11) liegt, überspannt.

5. Ein Bogen gemäß einem der vorhergehenden Ansprüche, dadurch gekennzeichnet, daß die durch Abschneiden gebildeten Oberflächenabschnitte (13) eine vom Rest der Ziegel unterschiedliche Farbe besitzen.

6. Ein Bogen gemäß irgendeinem der vorhergehenden Ansprüche, dadurch gekennzeichnet, daß der Bogenverlauf (11) auf einer Standard-Oberschwelle (14) aufruhrt, welche den Bauteil (15), über den sich der Bogen erstreckt, überspannt.

7. Ein Bogen gemäß einem der Ansprüche 1 bis 5, dadurch gekennzeichnet, daß die den Bogen bildenden Ziegel (12) durch eine Stange gehalten werden, welche über die Länge des Bogens durch die Ziegel (12) hindurchgeht.

8. Ein Satz von Ziegeln für die Herstellung eines Bogens, dadurch gekennzeichnet, daß die Ziegel (12) durch Abschneiden gebildete Oberflächenabschnitte (13) aufweisen, welche in ihrer Gesamtheit ein gewünschtes Muster, zum Beispiel eine gekrümmte Bogenform, definieren.

### Revendications

1. Arc comprenant une série de briques disposées côte à côte à la manière d'un arc horizontal proprement dit (11), caractérisé en ce qu'au moins certaines des briques (12) comportent une partie taillée (13) orientée vers l'avant, sur une partie de leur surface, de manière à définir un motif tout le long de l'arc.

2. Arc suivant la revendication 1, caractérisé en ce que les briques (12) sont généralement cuboïdes, compte non tenu de la partie taillée (13).

3. Arc suivant la revendication 1 ou 2, caractérisé en ce que les parties taillées (13) s'étendent dans la surface inférieure des briques (12) et leurs dimensions augmentent progressivement à mesure qu'elles s'approchent du milieu de l'arc (11).

4. Arc suivant l'une quelconque des revendications précédentes, caractérisé en ce que le motif s'étend sur toute la longueur de l'arc proprement dit enjambant ainsi l'objet (15) situé endessous de l'arc (11).

5. Arc suivant l'une quelconque des revendica-

tions précédentes, caractérisé en ce que la couleur des parties taillées (13) diffère de celle du reste des briques (12).

6. Arc suivant l'une quelconque des revendications précédentes, caractérisé en ce que l'arc proprement dit (11) est disposé sur un linteau de support ordinaire (14) qui enjambe l'objet (15) au-dessus duquel l'arc s'étend.

7. Arc suivant l'une quelconque des revendica-

tions 1 à 5, caractérisé en ce que les briques (12) formant l'arc sont supportées par une barre traversant ces briques (12) tout le long de l'arc proprement dit.

8. Ensemble de briques destiné à former un arc, caractérisé en ce que les briques (12) présentent des parties taillées (13) qui, ensemble, définissent progressivement un motif souhaité tel qu'un arc de forme courbe.

5

10

15

20

25

30

35

40

45

50

55

60

65

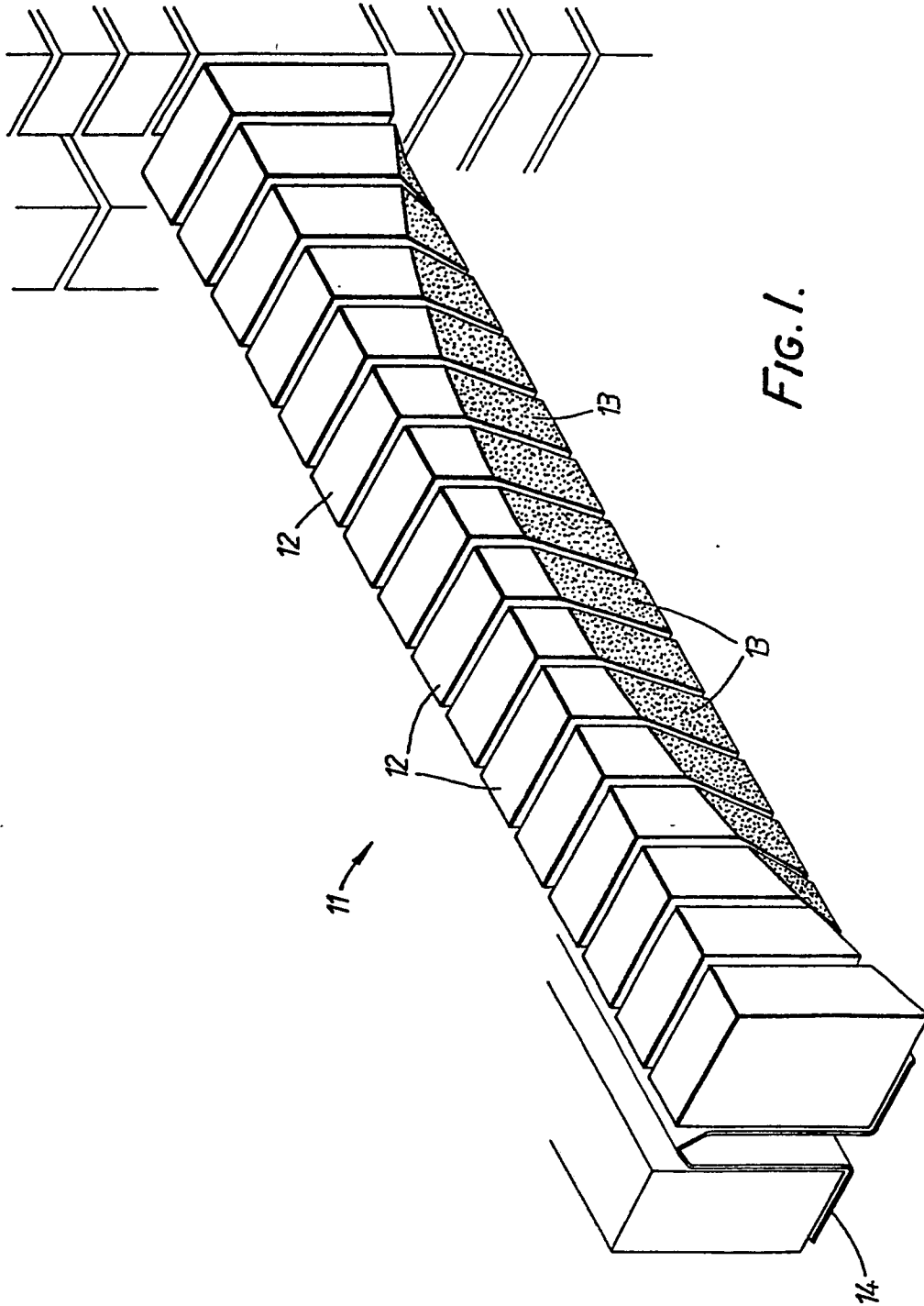

FIG. 1.

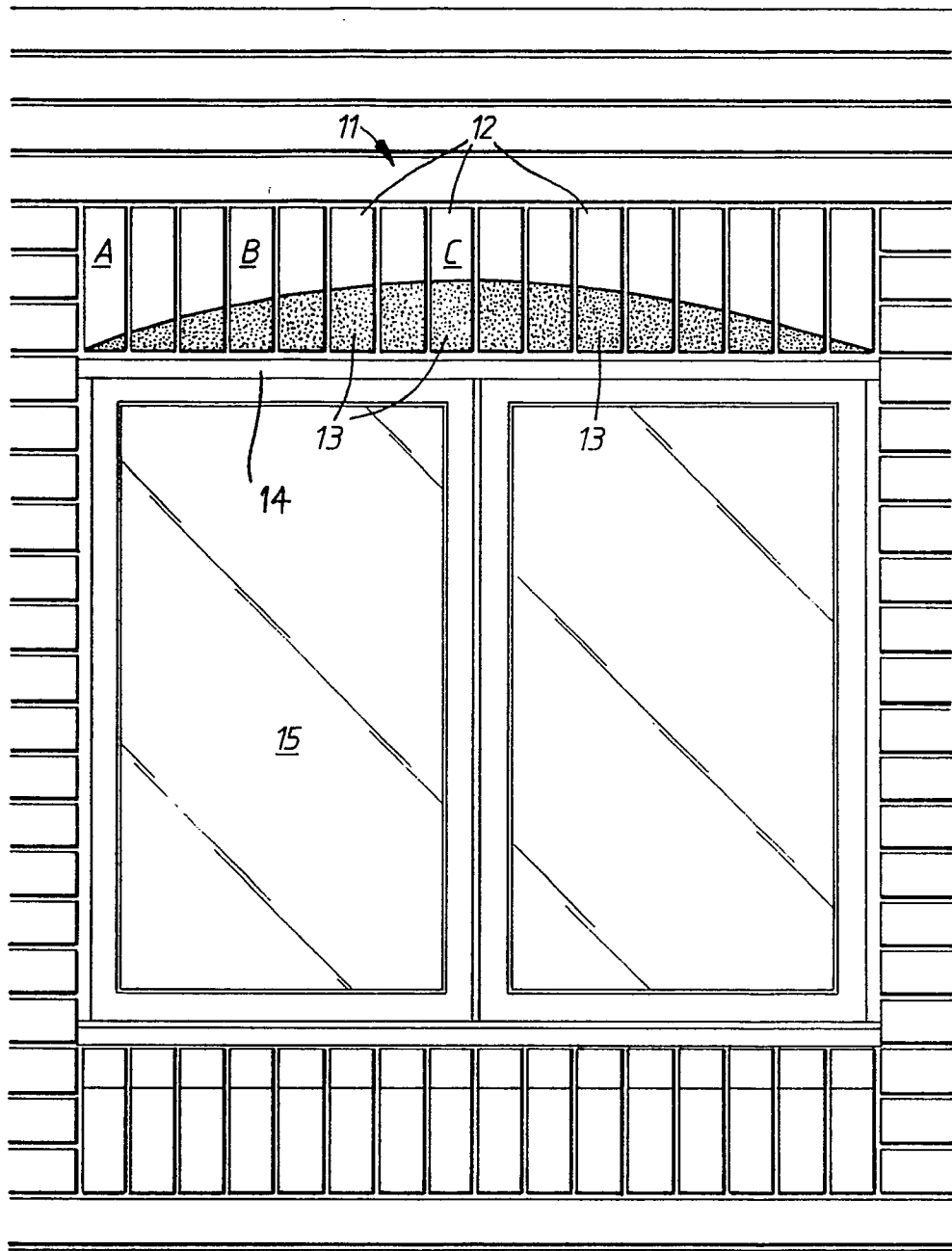

FIG. 2.

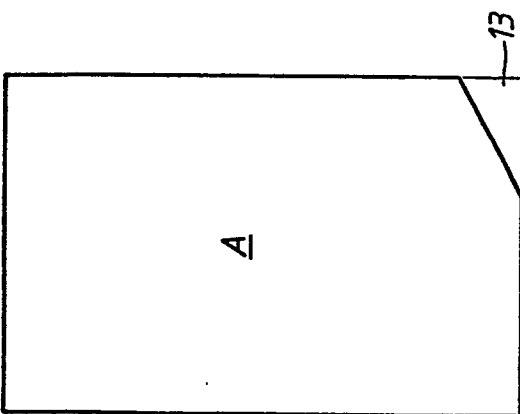

FIG. 3.

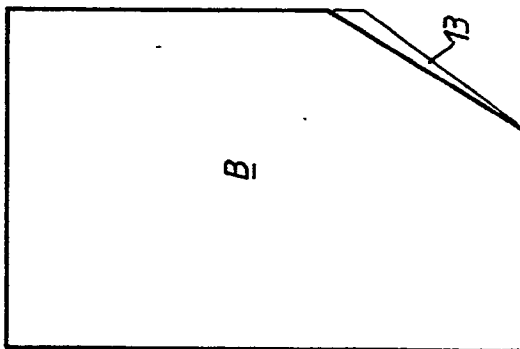

FIG. 4.

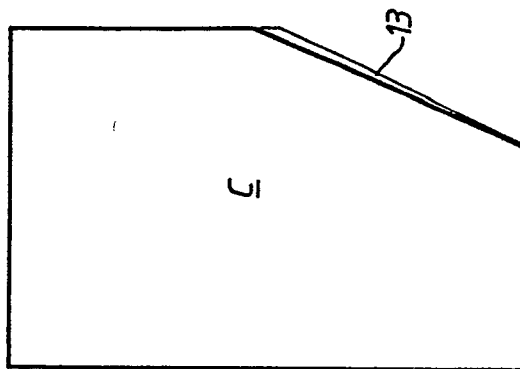
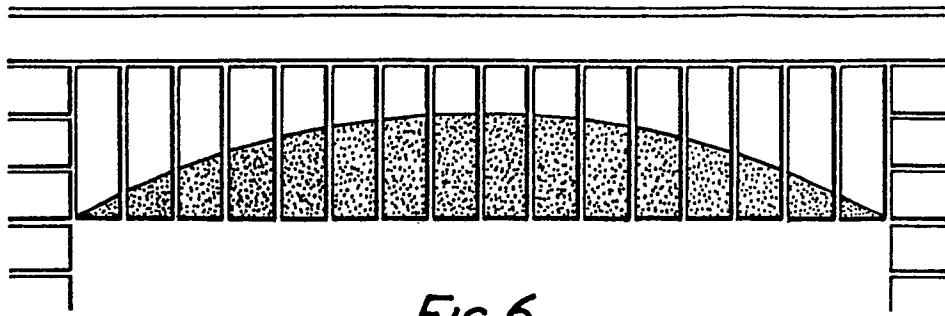
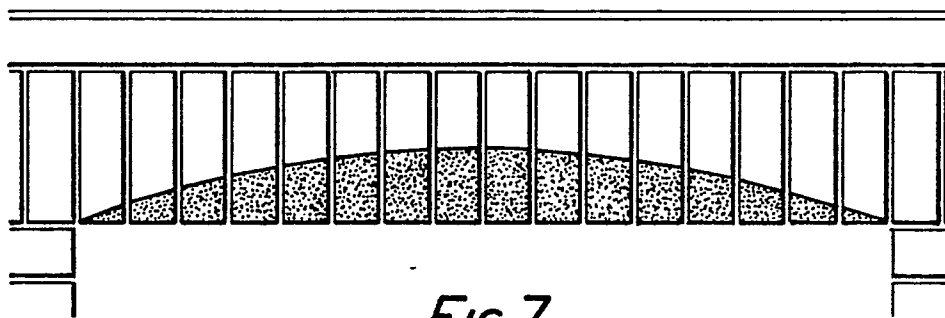

FIG. 5.



*FIG. 6.*



*FIG. 7.*

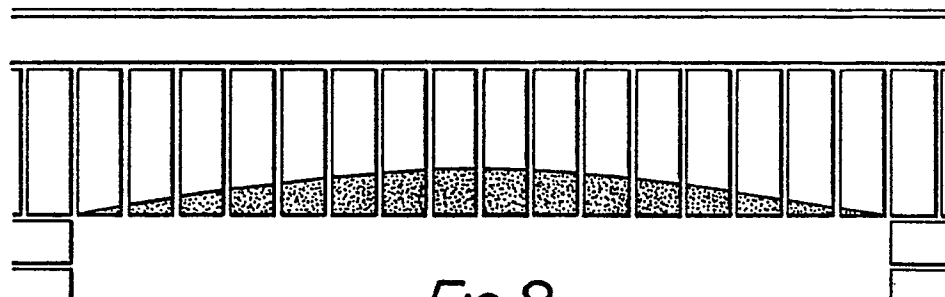

*FIG. 8.*

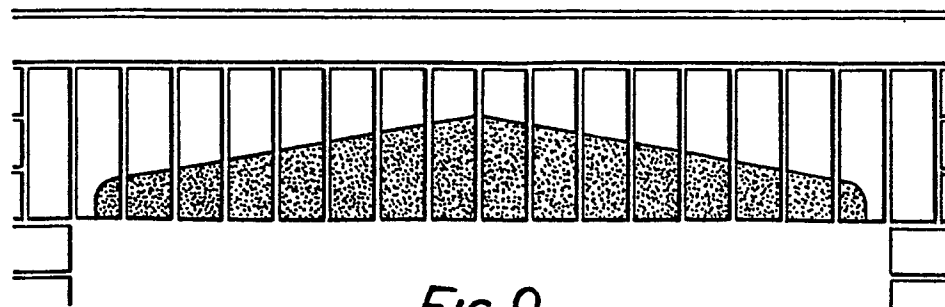

*FIG. 9.*