

**EUROPEAN PATENT SPECIFICATION**

- ④ Date of publication of patent specification: **23.11.88**      ⑤ Int. Cl.<sup>4</sup>: **G 03 G 15/00, G 03 G 15/20**
- ⑥ Application number: **85107953.3**
- ⑦ Date of filing: **01.03.82**
- ⑧ Publication number of the earlier application in accordance with Art. 76 EPC: **0 059 631**

**Guiding device in a copying apparatus.**

- ⑨ Priority: **02.03.81 JP 28445/81**  
**10.03.81 JP 32265/81**  
**10.03.81 JP 32266/81**
- ⑩ Date of publication of application:  
**22.01.86 Bulletin 86/04**
- ⑪ Publication of the grant of the patent:  
**23.11.88 Bulletin 88/47**
- ⑫ Designated Contracting States:  
**DE FR GB NL**
- ⑬ References cited:  
**PATENTS ABSTRACTS OF JAPAN, vol. 3, no. 113 (E-139), 19th September 1979, page E 139; & JP - A - 54 91 236 (KONISHIROKU SHASHIN KOGYO K.K.) 19-07-1979**  
**PATENTS ABSTRACTS OF JAPAN, vol. 3, no. 86 (E-125), 24th July 1979, page 141 E 125; & JP - A - 54 65 550 (KONISHIROKU SHASHIN KOGYO K.K.) 26-05-1979**  
**RESEARCH DISCLOSURE, no. 184, August 1979, page 430, no. 18445, Harvent, Hampshire, GB; D.W. BECKETT: "Post fuser copy sheet transport"**

- ⑭ Proprietor: **MITA INDUSTRIAL CO. LTD.**  
**2-28, 1-chome, Tamatsukuri Higashi-ku**  
**Osaka 540 (JP)**
- ⑮ Inventor: **Hisajima, Masahiko**  
**7-535 Otoda-cho**  
**Ikoma-shi Nara-ken (JP)**  
Inventor: **Kimura, Hiroshi**  
**296-5 Hirose**  
**Habikino-shi Osaka-Fu (JP)**  
Inventor: **Shigemura, Yutaka**  
**8-14-103 Takatsukasa 1-Chome**  
**Takarazuka-Shi Hyogo-Ken (JP)**  
Inventor: **Yada, Isao**  
**29-2 Ikeda-Naka-Machi**  
**Neyagawa-Shi Osaka-Fu (JP)**  
Inventor: **Irie, Yoichiro**  
**29-3 Aoyama-Dai 4-Chome**  
**Suita-Shi Osaka-Fu (JP)**  
Inventor: **Morimoto, Kiyoshi**  
**15-14 Daido 3-Chome**  
**Higashiyodogawa-Ku Osaka (JP)**  
Inventor: **Nagashima, Takashi**  
**10-5 Midori-Machi**  
**Neyagawa-Shi Osaka-Fu (JP)**
- ⑯ Representative: **Huntingford, David Ian et al**  
**W.P. THOMPSON & CO. Coopers Building**  
**Church Street**  
**Liverpool L1 3AB (GB)**

Note: Within nine months from the publication of the mention of the grant of the European patent, any person may give notice to the European Patent Office of opposition to the European patent granted. Notice of opposition shall be filed in a written reasoned statement. It shall not be deemed to have been filed until the opposition fee has been paid. (Art. 99(1) European patent convention).

## Description

This invention relates to a copying paper guiding device in a copying machine.

It is known to those skilled in the art that, for example in an electrostatic copying apparatus of the toner image transfer type, a sheet-like copying paper conveyed through a paper conveying passage has a toner image transferred thereon in a transfer zone, which image is then heat-fixed by a heat fixing device comprised of, for example, a pair of fixing rollers at least one of which is heated, and thereafter is discharged out of the housing of the copying apparatus while being guided by a paper guiding device. As such a paper guiding device, there is widely used a device of the type including a lower guide plate and an upper guide plate located opposite to each other and defining a paper moving passage therebetween.

This type of known paper guiding has, however, an important problem associated with it. Specifically, since the copying paper is heated to a high temperature in the heat fixing device, the copying paper which is to enter the paper guiding device from the heat fixing device is kept at a correspondingly high temperature. When the paper at such a high temperature is introduced into the paper moving passage of the guiding device between the upper and lower guide plates, the space between the lower and upper guide plates is heated by the heat dissipated from the copying paper, and consequently, dew tends to form on the upper side of the lower guide plate and the lower side of the upper guide plate. The dew drops so formed may adhere to the paper advancing through the guide means, and the paper itself and the toner image formed on it are likely to be deteriorated. Moreover, the smooth movement of the paper may be hampered, and paper jamming is likely to occur.

It is known from Japanese Patent Application No. 54-91236 to form a copying paper guiding device comprising a lower guide and an upper guide located opposite each other to define therebetween a path of movement for copying paper, the lower guide comprising a plurality of laterally spaced apart rising pieces which extend in the direction of movement of copying paper sheet along said path, and the upper guide comprising a plurality of laterally spaced apart hanging pieces extending in said direction of movement, the upper edges of the rising pieces co-operating with the lower edges of the hanging pieces to define said path of movement for the copying paper.

The mounting of the individual hanging and rising pieces in the known device results in a relatively complex and disadvantageous structure and it is an object of the present invention to provide a simpler structure which is more convenient to mount and dismount.

In accordance with the present invention, the lower guide is in the form of a guide plate having a main flat portion from which said rising pieces

extend, the upper guide is in the form of a guide plate having a main flat portion from which the hanging pieces depend,

the main flat portion of the upper guide plate is formed with through-holes,

the upper guide is detachably mounted on the lower guide,

side plates are disposed respectively at opposite side edge portions of each of the main flat portion of the lower guide plate and the main flat portion of the upper guide plate, and

the upper guide is detachably mounted on the lower guide by bringing a pin and a notch provided respectively at an upstream end portion and a downstream end portion of each of the side plates of the upper guide into engagement with a notch and pin provided respectively at an upstream end portion and a downstream end portion of each of the side plates of the lower guide.

The invention is described further hereinafter, by way of example only, with reference to the accompanying drawings, in which:

Figure 1 is an exploded perspective view showing one embodiment of a paper guiding device in accordance with the present invention, in which the upper guide plate is removed and separated from the lower guide plate;

Figure 2 is a perspective view of the guiding device shown in Figure 1, in which the upper guide plate is mounted in place on the lower guide plate;

Figure 3 is a sectional view taken along line X-X of Figure 2; and

Figure 4 is a sectional view taken along line XI-XI of Figure 3.

There is now described a paper guiding device in accordance with the invention for guiding a paper sheet conveyed through the conveying passage, which is especially suitable for guiding a paper sheet from a heat-fixing device in the paper conveying passage to outside the housing of a copying machine.

Referring to the drawings, the illustrated paper guiding device shown generally at 202, includes a lower guide plate 204 and an upper guide plate 206. It will be seen from Figures 1 and 3 that the lower guide plate 204 in the illustrated embodiment has a main flat portion 208, a curved portion 210 following the downstream end (the left end in Figure 3) of the main flat portion 208, and an upstanding portion 212 extending downwardly from the curved portion 210. A downwardly extending hanging portion 214 is formed integrally at each side edge of the main flat portion 208. The lower guide plate 204 is fixed in position in relation to the housing of a copying machine by keying the hanging portion 214 by means of a respective setscrew 218 to the inner surface of each of a pair of upstanding partitioning plates 216 disposed laterally in spaced-apart relationship within the housing of the copying machine, as shown in Figure 4. To the upper sides of the two opposite side edges of the main flat portion 208 of the lower guide plate 204 are

respectively keyed by means of setscrews 222 side plates 220 which extend upwardly from the upper sides substantially perpendicularly. In the upstream end portions (the right-hand end portion in Figure 3) of the side plates 220, elongate oblique groove-like notches 224 are respectively formed which extend respectively from the upper edges of the side plates 220 in the upstream direction downwardly and inclinedly. Inwardly projecting pins 226 are firmly set respectively at the downstream ends portions (i.e., the left-hand end portions in Figure 3) of the side plates 220.

As is readily seen from Figures 1 and 3, the upper guide plate 206 has a main flat portion 228, and at the opposite side edges of the main flat portion 228, there are respectively formed as an integral unit side plates 230 which extend downwardly therefrom substantially perpendicularly. Outwardly projecting pins 232 are firmly set respectively at the upstream end portions (i.e., the right-hand end portions in Figure 3) of the side plates 230. Furthermore, the downstream ends (i.e., the left-hand end portions in Figure 3) of the side plates 230 have respectively formed therein groove-like notches 234 which extend upwardly from the lower edges of the side plates 230. Grip portions 236 projecting in the downstream directions are also respectively formed in the downstream ends of the side plates 230. It will be readily appreciated from Figures 2 and 3 that the upper guide plate 206 described above can be detachably mounted in position on the lower guide plate 204 by operating the aforesaid grip portions 236 so as to position the upper guide plates 206 above the lower guide plate 204 with its side plates 230 being interposed between the side plates 220 of the lower guide plate 204, then moving the upstream end portions of the side plates 230 downwardly in the upstream direction to insert the pins 232 in the notches 224 formed in the upstream end portions of the side plates 220 of the lower guide plate 204, and thereafter moving the downstream end portions of the side plates 230 downwardly to bring the notches 234 into engagement with the pins 226 firmly set at the downstream end portions of the side plates 220 of the lower guide plate 204.

It is important that a plurality of rising pieces 238 should be provided laterally in spaced-apart relationship on the upper side of the main flat portion 208 of the lower guide plate 204, said rising pieces extending upwardly from the upper side of the main flat portion 208 in the moving direction of a copying paper (to the left and right in Figure 3), and that corresponding to these rising pieces, the lower side of the main flat portion 228 of the upper guide plate 206 should have formed thereon a plurality of hanging pieces 240 which are disposed laterally in spaced-apart relationship and extend downwardly from the lower side of the main flat portion 228 in the moving direction of the copying paper.

As is readily seen from Figures 1 and 4, six rising pieces 238 are provided laterally at suitable intervals on the upper side of the main flat portion

208 of the lower guide plate 204. The rising pieces 238 are fixed in position to the upper side of the main flat portion 208 by, for example, bonding the base portions of these rising pieces to the upper side of the main flat portion 208. The rising pieces 238 extend upwardly from the upper side of the main flat portion 208 substantially perpendicularly over a predetermined range in the moving direction of the copying paper (i.e., to the right and left in Figure 3). On the other hand, eight hanging pieces 240 are disposed laterally at suitable intervals on the lower side of the main flat portion 228 of the upper guide plate 206. The hanging pieces 240 are fixed in position to the lower side of the main flat portion 228 by, for example, bonding their base portions to the lower side of the main flat portion 228. These hanging pieces 240 extend downwardly from the underside of the main flat portion 228 substantially perpendicularly over a predetermined range in the moving direction of the copying paper (i.e., to the left and right in Figure 3). As Figures 3 and 4 clearly show, the rising pieces 238 and the hanging pieces 240 co-operate with each other to define a paper moving passage therebetween. Specifically, the upper edges of the rising pieces 238 co-operate with the lower edges of the hanging pieces 240 to define a path of paper movement therebetween, and a paper 242 (see Figures 1 and 3) moving through the paper guiding device 202 is guided by the upper edges of the rising pieces 238 and the lower edges of the hanging pieces 240. Preferably, as is clearly shown in Figure 3, the upstream end portions (i.e., the right-hand end portions in Figure 3) of the upper edges of the rising pieces 238 are inclined downwardly in the upstream direction, and the upstream end portions of the lower edges of the hanging pieces 240 are inclined upwardly in the upstream direction, so that the copying paper 242 (see Figures 1 and 3) advancing between the upper edges of the rising pieces 238 and the lower edges of the hanging pieces 240 is surely and easily guided by these rising and hanging pieces. Although in the illustrated embodiment, the rising pieces 238 are formed separately from the main flat portion 208 of the lower guide plate 204 and fixed to the upper side of the main flat portion 208, and the hanging pieces 240 are likewise formed separately from the main flat portion 228 of the upper guide plate 206 and fixed to the lower side of the main flat portion 228, it is possible, if desired, to form the rising pieces 238 integrally with the main flat portion 208 as a unit and to form the hanging pieces 240 integrally with the main flat portion 228 as a unit.

It is important that openings 244 should be formed in the main flat portion 228 of the upper guide plate 206. In the illustrated embodiment, eight rectangular openings 244 in total are formed in the main flat portion 228 of the upper guide plate 206 between the hanging pieces 240 and between the hanging pieces 240 and the side plates 230. Preferably, these openings 244 are as large as possible so long as they do not affect the

rigidity and strength of the upper guide plate 206, the bonding of the hanging pieces 240 to the lower side of the main flat portion 228, etc. It is also preferred that a rectangular opening 246 be formed in each of the hanging pieces 240 themselves. Such openings 246 are also preferably as large as possible so long as they do not affect the rigidity and strength of the hanging pieces 240, etc. The paper guiding device 202 shown in the drawings further comprises a delivery roller unit 248 disposed upstream (on the right in Figure 3) of the paper moving passage defined by the upper edges of the rising pieces 238 and the lower edges of the hanging pieces 240, and a discharge roller unit 250 disposed downstream (on the left in Figure 3) of the paper moving passage, as shown clearly in Figure 3. The delivery roller unit 248 is comprised of a plurality (5 in the drawing) of driven rollers 254 mounted on a driven shaft 252 at suitable intervals in the lateral direction and a plurality (5 in the drawing) of follower rollers 258 mounted on a follower shaft 256 correspondingly to the driven rollers 254. Likewise, the discharge roller unit 250 is comprised of a plurality (3 in the drawing) of driven rollers 262 mounted on a driven shaft 260 at suitable intervals in the lateral direction and a plurality (3 in the drawing) of follower rollers 266 mounted on a follower shaft 264 correspondingly to the driven rollers 262. The driven shaft 260 of the discharge roller unit 250 is positioned below the curved portion 210 of the lower guide plate 204, but as can be easily understood from Figure 1, the driven rollers 262 mounted on the driven shaft 260 project upwardly through cuts formed in the curved portion 210. The driven shaft 252 of the delivery roller unit 248 and the driven shaft 260 of the discharge roller unit 250 are rotatably supported on the pair of upstanding partitioning plates 216 (Figure 4) disposed within the housing of the copying machine. On the other hand, the follower shaft 256 of the delivery roller unit 248 and the follower shaft 264 of the discharge roller unit 250 are respectively inserted rotatably for free up-and-down movement in narrow slots 268 and 270 extending in the up-and-down direction and formed on the side plates 230 disposed on the opposite side edges of the upper guide plate 206. Accordingly, the follower shaft 256 of the delivery roller unit 248 and the follower rollers 258 mounted on it and the follower shaft 264 of the discharge roller unit 250 and the follower rollers 266 mounted on it are biased downwardly by their own weights. As a result, the follower rollers 258 of the delivery roller unit 248 are brought into abutment against the driven rollers 254, and the follower rollers 266 of the discharge roller unit 250 are brought into abutment against the driven rollers 262. If required, the follower shaft 256 of the delivery roller unit 248 and the follower shaft 264 of the discharge roller unit 250 may be resiliently biased downwardly by suitable spring members (not shown). The driven shaft 252 and the driven shaft 260 are drivingly connected to a suitable driving source (not

shown) such as an electric motor through a suitable power transmission means (not shown), and the delivery roller unit 248 and the discharge roller unit 250 are rotated in the direction of an arrow in Figure 3 by the action of the driving source.

In the illustrated paper guide device 202, a charge-eliminating brush member 272 known *per se* is fastened by means of a setscrew 274 to the downstream end (i.e. the left-hand end in Figure 3) of the upper guide plate 206. The lower end of the charge-eliminating brush member 272 contacts, or approaches the surface of the paper 242 (Figures 1 and 3) discharged from the paper guiding device 202 by the action of the discharge roller unit 250, thereby to remove the residual charge from the paper 242.

The operation and result of the paper guiding device 202 described hereinabove will now be described.

The paper guiding device 202 is suitably used for guiding the paper 242 (Figures 1 and 3) discharged from a heat-fixing device 276 and conducting it to outside the housing of the copying machine, although its function is not limited to this feature. For this purpose, the paper guiding device 202 is provided adjacent to, and downstream of, a heat-fixing device 276 (Figure 3). The heat-fixing device 276 (Figure 3), for example, includes a pair of heat-fixing rollers 278 (Figures 1 and 3) at least one of which is adapted to be heated by a suitable heat source (not shown) such as an electric resistance heating wire provided in its interior. By the action of such a pair of heat-fixing rollers 278, the copying paper 242 is slightly pressed to fix the toner image formed on the paper. As can be easily understood from Figure 3, the paper 242 discharged from the heat-fixing device 276 by the feeding action of the heat-fixing rollers 278 rotated in the direction of an arrow in Figure 3 is nipped by the delivery roller unit 248 of the paper guiding device 202 and sent to the paper guiding device 202 by the delivering action of the delivery roller unit 248. Then, the paper 242 is moved through the paper moving passage defined by the upper edges of the rising pieces 238 and the lower edges of the hanging pieces 240. Thereafter, the paper 242 is carried away from the paper guiding device 202 by the discharging action of the discharge roller unit 250, and then discharged into a receiving tray (not shown) outside the housing of the copying machine through a discharge opening (not shown) formed on the end wall of the housing.

In the heat-fixing device 276, the paper 242 is heated to a considerably high temperature by the heating action of the pair of heat-fixing rollers 278, and therefore, the paper 242 to be introduced into the paper guiding device 202 is at a considerably high temperature. When the paper 242 at such a high temperature enters the space between the lower guide plate 204 and the upper guide plate 206 of the paper guiding device 202, the space is heated by the heat dissipated from the paper 242. Since the outside of the paper

guiding device 202 is generally kept at room temperature or a temperature close to it, moisture (dew) tends to form on the upper side of the main flat portion 208 of the lower guide plate 204, the lower side of the main flat portion 228 of the upper guide plate 206, etc. However, because in the paper guiding device 202, the openings 244 are formed in the main flat portion 228 and the openings 246 are also formed in the hanging pieces 240, the heat dissipated from the paper 242 passed between the lower guide plate 204 and the upper guide plate 206 is effectively dissipated out of the paper guiding device 202 through these openings 246 and 244, and consequently, the moisture formation on the upper surface of the main flat portion 208, the under surface of the main flat portion 228, etc. can be effectively prevented. In addition, should such moisture formation occur in the main flat portions 208 and 228, etc., moisture is not likely to adhere to the paper 242 because the paper 242 passing between the lower guide plate 204 and the upper guide plate 206 advances through the paper moving passage defined by the upper edges of the rising pieces 238 and the lower edges of the hanging pieces 240, and makes contact only with very limited areas of the upper edges of the rising pieces 238 and the lower edges of the hanging pieces 240. Consequently, no deterioration due to the adhesion of moisture occurs in the paper 242 itself or the toner image formed on it, nor is there paper jamming as a result of the smooth movement of the paper 242 being hampered by the moisture formation. In more detail, when relatively large drops of moisture form on the upper side of the main flat portion 208 of the lower guide plate 204, or the side surfaces of the rising pieces 238, these drops are not likely to adhere to the paper 242. But, were relatively large drops of moisture to form on the underside of the main flat portion 228 of the upper guide plate 206 or on the side surfaces of the hanging pieces 240, these drops would be likely to adhere to the paper 242 advancing between the lower guide plate 204 and the upper guide plate 206. However, as a result of the construction of the paper guiding device 202, the aforesaid relatively large drops of moisture do not form on the underside of the main flat portion 228 or on the hanging pieces 240 because openings are formed both on the main flat portion 228 and on the hanging pieces 240 to greatly reduce the heat capacity of the main flat portion 228 and the hanging pieces 240 and the actual areas of the underside of the main flat portion 228 and the side surfaces of the hanging pieces 240 on which dew could form are markedly decreased. If desired, openings may also be provided in the main flat portion 208 of the lower guide plate 204 and/or the rising pieces 238 to dissipate the heat more effectively from the space between the lower guide plate 204 and the upper guide plate 206 to outside the paper guiding device 202 and thus to further reduce the likelihood of dew formation on the upper side of the main flat portion 208 of the lower guide plate 204 and/or the side surfaces of the rising pieces 238.

## Claims

1. A copying paper guiding device comprising a lower guide (204) and an upper guide (206) located opposite each other to define therebetween a path of movement for copying paper, the lower guide (204) comprising a plurality of laterally spaced apart rising pieces (238) which extend in the direction of movement of a copying paper sheet along said path, and the upper guide (206) comprising a plurality of laterally spaced apart hanging pieces (240) extending in said direction of movement, the upper edges of the rising pieces cooperating with the lower edges of the hanging pieces to define said path of movement for the copying paper, characterised in that

the lower guide (204) is in the form of a guide plate having a main flat portion (208) from which said rising pieces (238) extend,

the upper guide (206) is in the form of a guide plate having a main flat portion (228) from which the hanging pieces (240) depend,

the main flat portion (228) of the upper guide plate is formed with through-holes (244),

the upper guide (206) is detachably mounted on the lower guide (204),

side plates (220, 230) are disposed respectively at opposite side edge portions of each of the main flat portion (208) of the lower guide plate (204) and the main flat portion (228) of the upper guide plate (206), and

the upper guide (206) is detachably mounted on the lower guide (204) by bringing a pin (232) and a notch (234), provided respectively at an upstream end portion and a downstream end portion of each of the side plates (230) of the upper guide (206) into engagement with a notch (224) and pin (226) provided respectively at an upstream end portion and a downstream end portion of each of the side plates (220) of the lower guide (204).

2. A copying paper guide device according to claim 1, wherein the notches (224) of the lower guide (204) extend obliquely and downwardly from the upper edges of the side plates (220), considered in the upstream direction in relation to said path of movement of the copying paper.

3. A copying paper guide device according to claim 1 or 2, wherein the notches (234) of the upper guide (206) extend upwardly from the lower edges of the side plates (230).

4. A copying paper guide device according to claim 1, 2 or 3, wherein a respective through-hole (246) is formed in the hanging pieces (240).

## Patentansprüche

1. Kopierpapier-Führungselement, das eine untere Führung (204) und eine obere Führung (206), die einander gegenüber angeordnet sind, um dazwischen eine Laufstrecke für das Kopierpapier festzulegen, aufweist, wobei die untere Führung (204) eine Vielzahl von in seitlichem Abstand angeordneten Standteilen (238), welche sich, in Richtung der Bewegung eines Kopierpapierblattes entlang der Laufstrecke erstrecken aufweist,

wobei die obere Führung (206) eine Vielzahl von in seitlichem Abstand angeordneten Hängeteilen (240), welche sich in der Richtung der Bewegung erstrecken, aufweist, und wobei die oberen Enden der Standteile mit den unteren Enden der Hängeteile zusammenwirken, um dadurch die Laufstrecke für das Kopierpapier zu definieren, dadurch gekennzeichnet,

daß die untere Führung (204) die Form einer Führungsplatte hat, die einen flachen Hauptteil (208) aufweist, von dem aus sich die Standteile (238) erstrecken,

daß die obere Führung (206) die Form einer Führungsplatte hat, die einen flachen Hauptteil (228) aufweist, von dem aus die Hängeteile (240) herabhängen,

daß der flache Hauptteil (228) der oberen Führungsplatte ausgebildet ist mit Durchgangsbohrungen (244),

daß die obere Führung (206) ablösbar an der unteren Führung (204) befestigt ist,

daß die Seitenplatten (220, 230) an den entsprechenden gegenüberliegenden seitlichen Enden sowohl des flachen Hauptteils (208) der unteren Führungsplatte (204) als auch des flachen Hauptteils (228) der oberen Führungsplatte (206) angeordnet sind, und

daß die obere Führung (206) ablösbar befestigt ist an der unteren Führung (204), indem ein Zapfen (232) und eine Aussparung (234), die entsprechend an einem oberen Ende und an einem unteren Ende einer jeden Seitenplatte (230) der oberen Führung (206) vorgesehen sind, in Eingriff gebracht werden mit einer Aussparung (224) und einem Zapfen (226), die entsprechend an einem oberen Ende und an einem unteren Ende einer jeden Seitenplatte (220) der unteren Führung (204) vorgesehen sind.

2. Kopierpapier-Führungselement gemäß Anspruch 1, dadurch gekennzeichnet, daß die Aussparungen (224) der unteren Führung (204) ausgehend von den oberen Enden der Seitenplatten (220) sich schräg nach unten erstrecken, betrachtet in der in bezug auf die Laufstrecke des Kopierpapiers entgegengesetzten Richtung.

3. Kopierpapier-Führungselement gemäß Anspruch 1 oder 2, dadurch gekennzeichnet, daß die Aussparungen (234) der oberen Führung (206) sich ausgehend von den unteren Enden der Seitenplatten (230) nach oben erstrecken.

4. Kopierpapier-Führungselement gemäß einem der Ansprüche 1 bis 3, dadurch gekennzeichnet, daß in den Hängeteilen (240) entsprechende Durchgangsbohrungen (246) ausgebildet sind.

## Revendications

1. Dispositif de guidage de papier de copie comprenant un guide inférieur (204) et un guide supérieur (206) placés de façon opposée l'un par

rapport à l'autre pour définir entre eux un chemin de passage pour du papier de copie, le guide inférieur (204) comprenant une pluralité de pièces (238) en saillie espacées latéralement l'une par rapport à l'autre et s'étendant dans la direction de mouvement de la feuille de papier de copie le long dudit chemin, et le guide supérieur (206) comprenant une pluralité de pièces suspendues (240) espacées latéralement l'une par rapport à l'autre et s'étendant dans ladite direction de mouvement, les bords supérieurs des pièces en saillie coopérant avec les bords inférieurs des pièces suspendues pour définir ledit chemin de mouvement pour le papier de copie, caractérisé en ce que

le guide inférieur (204) a la forme d'un plateau de guidage ayant une partie principale plate (208) à partir de laquelle lesdites pièces en saillie (238) s'étendent,

le guide supérieur (206) a la forme d'un plateau de guidage ayant une partie principale plate (228) sous laquelle les pièces suspendues (240) pendent,

la partie principale plate (228) du plateau de guidage supérieur est conçue avec des trous de passage (244),

le guide supérieur (206) est monté de façon amovible sur le guide inférieur (204),

des plaques de côté (220, 230) sont placées respectivement aux bords des côtés opposés de la partie principale (208) de la plaque de guidage inférieure (204) et de la partie plate principale (228) de la plaque de guidage supérieure (206), et

le guide supérieur (206) est monté de façon amovible sur le guide inférieur (204) en plaçant un téton (232) et une encoche (234), placés respectivement à une partie terminale en amont et une partie terminale en aval de chacune des plaques de côtés (230) du guide supérieur (206) en engagement avec une encoche (224) et un téton (226) prévus respectivement à une partie terminale amont et une partie terminale aval de chacune des plaques de côtés (220) du guide inférieur (204).

2. Dispositif de guidage de papier de copie copier selon la revendication 1, dans lequel les encoches (224) du guide inférieur (204) s'étendent de manière oblique et vers le bas à partir des bords supérieurs des plaques de côtés (220), dans la direction amont par rapport audit passage de mouvement du papier de copie.

3. Dispositif de guidage de papier de copie selon la revendication 1 ou 2, dans lequel les encoches (234) du guide supérieur (206) s'étendent vers le haut à partir des bords inférieurs des plaques de côtés (230).

4. Dispositif de guidage de papier de copie selon la revendication 1, 2 ou 3, dans lequel un trou de passage respectif (246) est formé dans les pièces suspendues (240).

5

10

15

20

25

30

35

40

45

50

55

60

65

6

FIG. 1

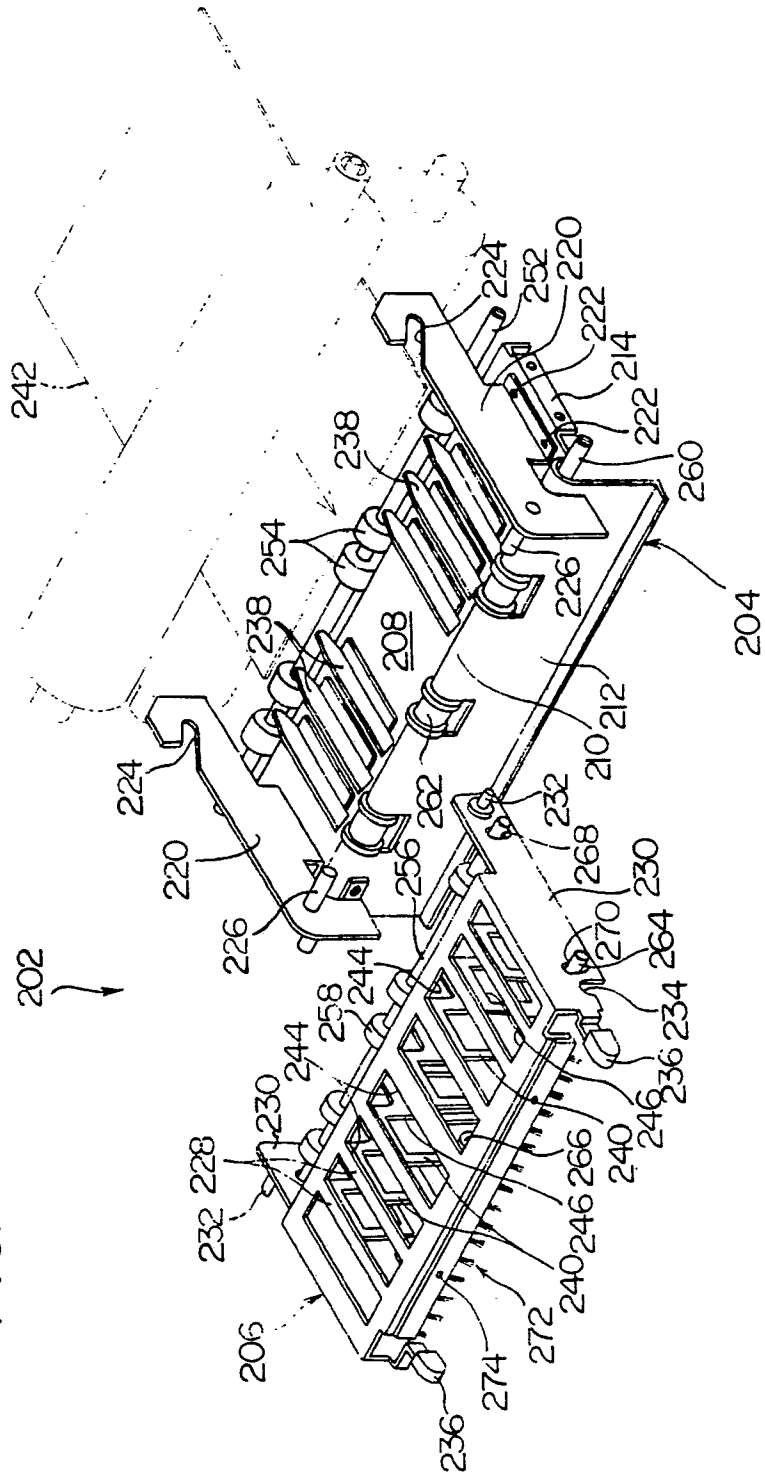



FIG. 3

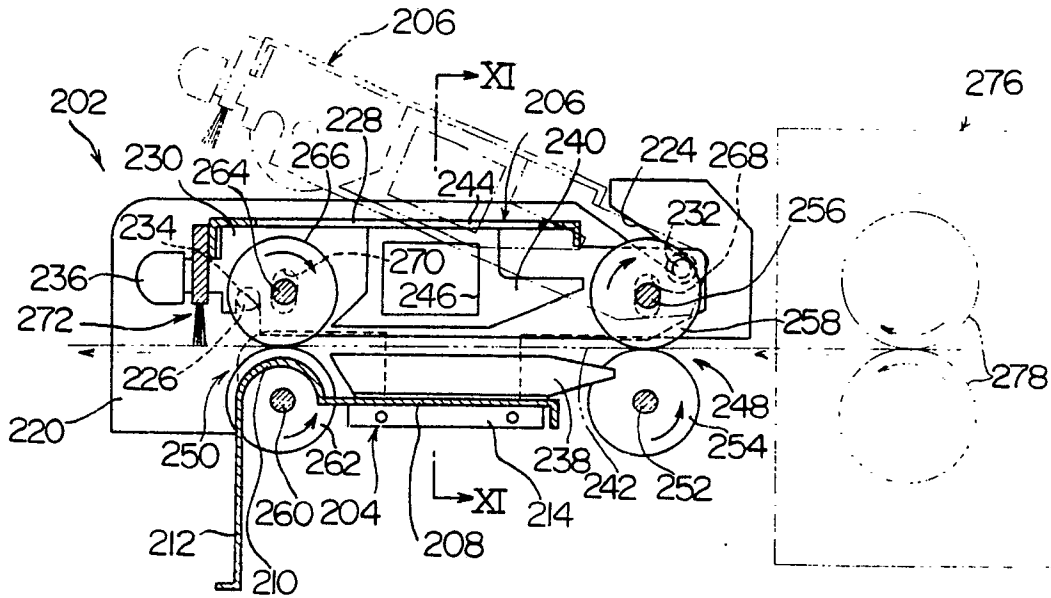

FIG. 4

