

EUROPEAN PATENT APPLICATION

Application number: 84308567.1

Int. Cl.⁴: B 42 D 15/02

Date of filing: 10.12.84

Date of publication of application:
02.07.86 Bulletin 86/27

Designated Contracting States:
AT BE DE FR GB NL SE

Applicant: **COMPUTER IDENTIFICATION SYSTEMS, INC.**
874- 57th Street
Sacramento California 95819(US)

Inventor: **Phelps, Barry C.**
4100 Folsom Boulevard
Sacramento California 95819(US)

Representative: **Newstead, Michael John et al,**
Page & Co. Temple Gate House Temple Gate
Bristol BS1 6PL(GB)

Coloured engraved identification card.

An engraved identification card with a multi-colored image engraved thereon includes a card with a base ply (12), a top ply (14), and a plurality of colored plies (18, 20, 22, 24, 26) between the top ply and the base ply. Each colored ply is a color different from the color of each adjacent ply. The card has a multiplicity of engraved cavities where each cavity has a depth selected to expose one or more portions of one or more of the top, colored, or base plies. The resultant multiplicity of exposed portions of the different plies cooperate together to form the colored image on the card. The cavities may be a multiplicity of individually drilled holes (28, 30) or may be a multiplicity of longitudinal grooves or furrows (52)

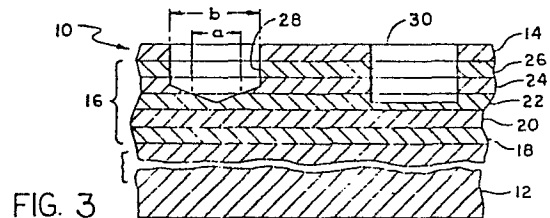

FIG. 3

COLORED ENGRAVED IDENTIFICATION CARD

Background of the Invention

5

The present invention relates to identification cards and in particular to identification cards variably engraved into a plurality of colored plies to form a multicolored engraved image.

10

Various engraved identification cards are known. For example, in Oka et al., Patent No. 3,897,964 an engraved identification has a multiplicity of longitudinal scores of variable depth into a dual ply card blank to form a black and white image. Another engraved card disclosed in Hell Patent No. 2,986,598, employs a plurality of holes through, for example, a white layer into a black layer.

15

20

In each of these patents, an impression in the form of either a groove or point is made through a black or white layer of a plastic card into a second layer of a different color. By varying the depth of the groove or hole, varying areas of the underlying contrasting layer will be exposed.

25

30

In Oka et al., Patent No. 3,930,924, a card with two or more colored layers is disclosed. When such a card is engraved, the result is a picture with a multi-colored effect.

5

By contrast, the identification card in accordance with the invention has a plurality of different colored plies of predefined thickness at predefined depths. For example, the card could have a bottom ply which is black, a next ply which is red, a next ply which is blue, a next ply which is green, and a top ply which is white. Cards having one colored layer which is flesh tone can also be provided. The colored engraved image can then be formed for example by drilling or punching a multiplicity of holes through one or more of the colored layers to expose a small region of color from one of the plies. The combination of a multiplicity of exposed regions creates an image somewhat like a dot pattern image of a color television picture. The thickness of the card and the thickness of each of the plies is precisely controlled so that an engraving machine can expose the desired color in selected regions to form the colored image.

25

The colored plies are preferably relatively thin so that when a hole of relatively small width is formed by punching or scribing, the exposed color will still be easily observed. It will be appreciated that the width of the holes or furrows in the card must be sufficiently wide relative to the thickness of the plies so that the exposed region in a hole or furrow of maximum depth will not be "buried" at the bottom of the hole or furrow in such a way that light will not be able to illuminate the exposed portion.

35

On the other hand, the thickness of each ply must be great enough so that the engraving device will be able to consistently drill or scribe into a selected ply.

5

10

15

20

25

30

35

Summary of the Invention

5 A multicolored engraved identification card includes base ply which may for example be black in color, a top ply which may for example be white in color, and a plurality of colored plies between the top ply and the base ply. The color of each intermediate colored ply is different from the color of each immediately adjacent ply. The card further includes a multiplicity of cavities which may be holes or elongated grooves where each cavity has a depth which is selected to expose one or more portions of at least one of the plies including the base ply, the top ply and the plurality of colored plies. The multiplicity of exposed portions cooperate to form the colored image on the card.

10 In one embodiment, the plurality of colored plies includes three plies each of which has a color other than black or white and additionally a plurality of white plies arranged so that a white ply is interleaved between each colored ply which is not black or white.

15 Each cavity preferably has a width relative to the combined thickness of the top ply and each colored ply which will allow simultaneous viewing of the multiplicity of exposed portions. To achieve such simultaneous viewing of the exposed regions, the width of each cavity is preferably selected to be greater than its depth with the top ply and each colored ply having substantially the same thickness.

Brief Description of the Drawings

A complete understanding of the present invention and of the above and other features may be gained from a
5 consideration of the following description of the preferred
embodiments taken in conjunction with the accompanying
drawings in which:

10 FIG. 1 is a top view of an engraved identification
card formed in a multi-ply card where the depth of each
engraved hole determines the color to be exposed.

15 FIG. 2 is a top view of an engraved multi-ply card
where the engravings are furrows of varying depths along
their length.

FIG. 3 is a partial cross-sectional view through
section 3-3 in Fig. 1.

20 FIG. 4 is a partial cross-sectional view through
section 4-4 in Fig. 2.

25 FIG. 5 is a partial cross-sectional view through
section 5-5 in Fig. 2.

30

35

Detailed Description

Referring initially to Figure 1 in conjunction with Figure 3, one embodiment of a card with an engraved colored image 11 includes a base ply 12, a top ply 14 and a plurality of colored plies 16 between the top ply 14 and the base ply 12. Each of the plurality of colored plies 16 is of a color which is different from the color of each adjacent ply whether the base ply, the top ply or an adjacent colored ply.

For example, in Figure 3, the plurality of colored plies is illustrated as including five plies. The first colored ply 18 is disposed on top of the base ply 12 and has a first color; a second colored ply 20 is disposed on the first ply 18 and has a second color; a third colored ply 22 is disposed on the second ply 20 and has a third color; a fourth ply 24 is disposed on top of the third ply 22 and has a fourth color; and a fifth ply 26 is disposed on top of the fourth ply 24 and has a fifth color. In accordance with the invention, the first color is different from the color of the base and from the second color; the second color is additionally different from the third color; the third color is additionally different from the fourth color; and the fourth color additionally different from the fifth color. The color of the top ply 14 is then also different from the color of the fifth colored ply 26.

Of course, it will be appreciated that a greater or lesser number of different colored plies may be incorporated without departing from the spirit of the invention. Nevertheless, in general, a full colored image can be obtained

0185807

using only three primary colors since it is possible to substantially reproduce a colored image by color separating the image and then exposing appropriate regions of each colored layer corresponding to the color separated parts of the colored image to be engraved.

Referring again to the illustrated embodiment of Figure 3, the base ply is black, the top ply 14 is white and the intermediate colored plies 20 and 24 are likewise white in color. The first ply 18, third ply 22 and fifth ply 26 are selected to be, for example, the primary colors red, blue and green. Alternatively or additionally, a flesh colored ply could be incorporated to enable better imaging for pictures of humans. By providing a white ply between the first and third plies and third and fifth plies in conjunction with a white top ply, a hole 28 can be drilled with a conically shaped drill bit to expose varying areas 29 of the selected portion of one of the colored layers where the exposed area will have a diameter "a" smaller than the diameter "b" of the drill bit. Hence, the portion of the non-white colored layer which is exposed can be varied by controlling the depth of the hole 28 drilled through the multi-ply card.

25

For example, in Figure 3, the hole 28 is drilled to a predefined depth with a conically shaped drill bit to expose the circular area 29 in the third colored ply 22. By increasing the depth of the hole 28 by a slight amount, the diameter "a" of the exposed region 29 in the third colored layer 22 will be increased which in effect increases the intensity of that color to a viewer. It will be appreciated, of course, that in order for the drill to expose no more than two adjacent colored layers, it is necessary that the vertical distance between the center of the hole and the junction

35

33 between the sloped bottom surface 31 and the side 35 of the hole 28 be less than the thickness of any of the plies 18, 20, 22, 24, 26 and 14.

5 Of course, it will also be appreciated that the hole may have a perfectly flat bottom as illustrated by the hole 32 in Figure 3.

10 Returning to Figure 1, by drilling a plurality of additional holes 30 of varying depths into the multi-ply card 10, small portions of the colored layers at predefined locations will be exposed to form the image 11 as above-described. It will be appreciated that in order for all of the exposed portions to be simultaneously
15 - visible to a viewer the width of each hole (or furrow as will be described hereafter) should be sufficiently wide relative to the combined thickness of the top ply and each colored ply. It is also preferred that the holes be drilled as close together as possible and that the
20 holes be as small as possible to increase image resolution.

 Referring next to Figures 2, 4 and 5, an alternative embodiment is shown wherein the exposed portions occur
25 as a consequence of grooves or furrows having varying depths along their lengths. Thus, in Figure 2, a card 50 in accordance with the invention includes a multiplicity of closely adjacent furrows 52 which are engraved into the surface of the card.

30 Referring to Figure 4, a partial cross-sectional view through section 4-4 of the engraved card 50 is illustrated. The card 50 includes a base ply 54 which,

35

for example, may be colored black; a first colored ply 56 disposed on the base ply and may, for example, be colored red; a second colored ply 58 disposed on top of the first colored ply 56 and may, for example, be colored green; and a third colored ply 60 disposed on top of the second colored ply 58 and may, for example, be colored blue. The top ply 62 is then disposed on top of the third colored ply 60. The top ply 62 is preferably white.

Of course, any other set of colors may be used for the various plies without departing from the spirit of the present invention. The cavity or furrow 52 illustrated in Figure 4 preferably has a substantially rectangular shape so that only one color is exposed across the width of the furrow 52.

Referring to Figure 5, a partial cross-section of the furrow through section 5-5 of Figure 2 is illustrated where the furrow 52 has varying depths along its length. For example, the furrow 52 extends through the plies 62, 60 and 58 into ply 56 to expose a lengthwise region 64 of the ply 56. The furrow 52 next becomes shallower in the adjacent region 66 to expose a portion of the ply 58 and becomes shallower in the region 68 to expose a portion of the ply 60. To an observer, a different color will be visible in the regions 64, 66 and 68. Therefore, it can be seen that by varying the depth of the furrow along the length of the furrow 52, regions of different color can be exposed which, when coordinated to correspond to the regions of color in a photograph for example, will result in an engraved colored image corresponding to the photograph.

It will be appreciated that various arrangements of plies may be utilized in accordance with the invention. For example, in the embodiment illustrated in Figures 2, 4 and 5, it may be preferable to include an additional
5 ply with the color sequence from the top ply to the base ply being white, blue, green, red, blue, and black. In such an arrangement, each colored ply would be adjacent to a ply having one of the other two colors. In another embodiment, the base ply
10 the top ply black and each intermediate white ply as shown in Figure 3 in connection with the first embodiment could likewise be black instead of white.

It will be appreciated that various other
15 arrangements and embodiments of the present invention are possible without departing from the invention in its broadest aspects. Consequently, the aim in the appended claims to cover all such changes and modifications as
20 fall within the true spirit and scope of the invention.

20

25

30

35

CLAIMS

1. A card having a colored image engraved thereon comprising:
 - 5 a base ply;
 - a top ply; and
 - a plurality of colored plies between the top ply and the base ply, each colored ply having a color different from the color of each adjacent ply, the card having a multiplicity of cavities engraved
 - 10 therein, each having a depth selected to expose at least one portion of at least one of the base, top or colored plies, the multiplicity of exposed portions cooperating to form the colored image on the card.
2. The card of claim 1 wherein the base ply is
- 15 black.
3. The engraved colored image identification card of claim 1 or 2 wherein the top ply is white.
4. The card of any preceding claim wherein the plurality of colored plies comprises:
 - 20 a first ply of a first color disposed on the base ply;
 - a second ply of a second color disposed on the first ply; and
 - a third ply of a third color disposed on the
 - 25 second ply, the first, second and third colors being colors other than black and white.
5. The engraved colored image identification card of any preceding claim further comprising a plurality of white colored plies, one of the white
- 30 colored plies interleaved between two colored plies being of colors other than black and white.
6. The card of any preceding claim wherein the width of each cavity is greater than its depth.
7. The card of any preceding claim wherein the
- 35 top ply and each colored ply has substantially the same thickness.
8. The card of any preceding claim wherein the combined thickness of the top ply and each colored ply

is less than the width of each cavity.

9. The card of any preceding claim wherein the width of each cavity is selected to be sufficiently wide relative to the combined thickness of the top ply and each colored ply to enable simultaneous viewing
5 of the multiplicity of exposed portions.

10. The card of any preceding claim wherein each cavity is a hole having a circular cross-section.

11. The card of any of claims 1 to 9 wherein each
10 cavity is an elongated furrow having a variable depth along its length to define the at least one exposed portion.

15

20

25

30

35

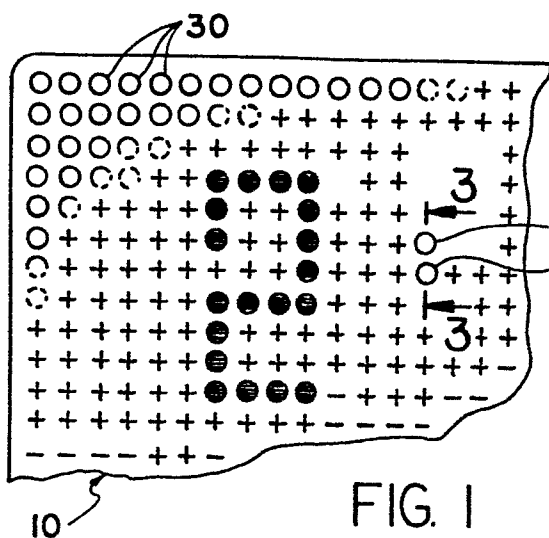

FIG. 1

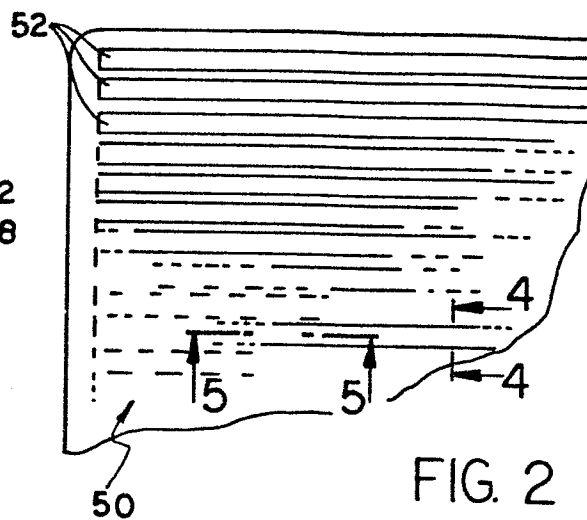

FIG. 2

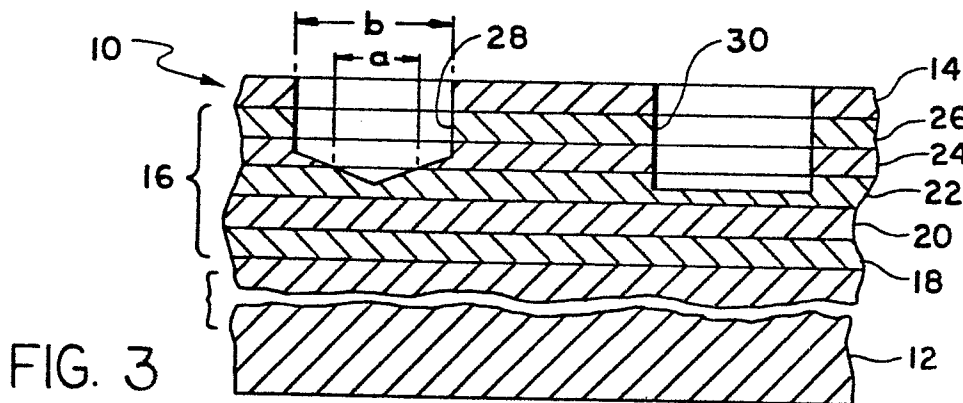

FIG. 3

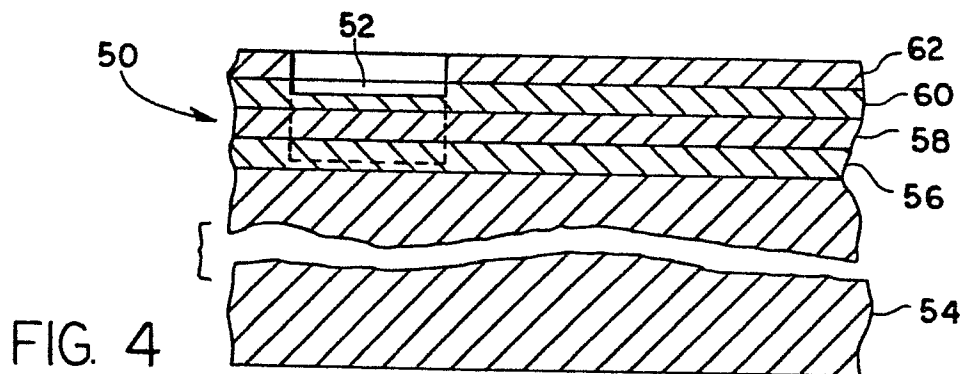

FIG. 4

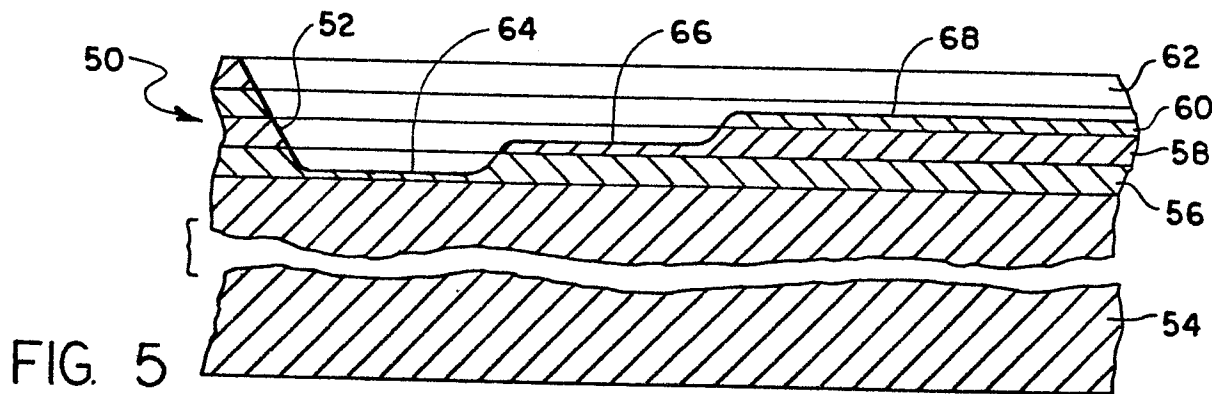

FIG. 5



DOCUMENTS CONSIDERED TO BE RELEVANT			
Category	Citation of document with indication, where appropriate, of relevant passages	Relevant to claim	CLASSIFICATION OF THE APPLICATION (Int. Cl. 4)
X	FR-A-2 496 937 (G.A.O. GmbH) * Figures 1-3; page 4, lines 17-28; page 5, lines 19-30; page 7, line 37 - page 8, line 3; page 8, lines 27-33; page 9, lines 17-19 *	1,4,6, 8-11	B 42 D 15/02
Y		2,3,5, 7	
Y	--- US-A-4 223 918 (F.E. SMOZYNSKI) * Column 2, lines 36-39; column 3, lines 24-37 *	3,5,7	
Y	--- US-A-4 052 739 (M. WADA et al.) * Column 2, line 60 - column 3, line 12 *	2	TECHNICAL FIELDS SEARCHED (Int. Cl. 4)
A,D	--- US-A-3 897 964 (S. OKA et al.)	1	B 42 D
A,D	--- US-A-3 930 924 (S. OKA et al.)	1	

The present search report has been drawn up for all claims			
Place of search THE HAGUE		Date of completion of the search 07-08-1985	Examiner WEBER P.L.P.
<p>CATEGORY OF CITED DOCUMENTS</p> <p>X : particularly relevant if taken alone Y : particularly relevant if combined with another document of the same category A : technological background O : non-written disclosure P : intermediate document</p> <p>T : theory or principle underlying the invention E : earlier patent document, but published on, or after the filing date D : document cited in the application L : document cited for other reasons & : member of the same patent family, corresponding document</p>			