

⑫ **EUROPEAN PATENT SPECIFICATION**

- ⑬ Date of publication of patent specification: **01.06.88**      ⑮ Int. Cl.<sup>4</sup>: **B 05 D 1/32, B 05 D 1/28,**  
**B 05 D 7/16, B 05 D 3/12**
- ⑰ Application number: **85103211.0**
- ⑱ Date of filing: **20.03.85**

⑳ **Method of coil coating a strip of blackplate or a substrate based on blackplate intended for use in the manufacture of cans and/or can parts.**

㉑ Date of publication of application:  
**24.09.86 Bulletin 86/39**

㉒ Publication of the grant of the patent:  
**01.06.88 Bulletin 88/22**

㉓ Designated Contracting States:  
**BE DE FR GB IT LU NL**

㉔ References cited:  
**FR-A-2 089 902**  
**FR-A-2 513 596**  
**US-A-4 032 678**  
**US-A-4 378 390**

**FARBE & LACK, vol. 85, no. 9, September 1979,**  
**pages 744-748, Hannover, DE; E.V. SCHMID et**  
**al.: "Der Coil-Coating-Prozess von Leichtmetall"**

**METALLOBERFLÄCHE, vol. 38, no. 5, 1984,**  
**pages 219-224, Munich, DE; K.-D. TÖLKE:**  
**"Qualitätseigenschaften bandbeschichteter**  
**Aluminiumoberflächen"**

㉕ Proprietor: **HOOGOVS GROEP B.V.**  
**P.O. Box 10.000**  
**NL-1970 CA IJmuiden (NL)**

㉖ Inventor: **Bunk, Huig**  
**Stumphiusstraat 29**  
**NL-1942 EN Beverwijk (NL)**

㉗ Representative: **Wentzel, Hendrik Cornelis et al**  
**Hoogovens Groep B.V. P.O. Box 10.000**  
**NL-1970 CA IJmuiden (NL)**

Note: Within nine months from the publication of the mention of the grant of the European patent, any person may give notice to the European Patent Office of opposition to the European patent granted. Notice of opposition shall be filed in a written reasoned statement. It shall not be deemed to have been filed until the opposition fee has been paid. (Art. 99(1) European patent convention).

**EP 0 195 099 B1**

## Description

The invention relates to a method of coil coating a layer of organic coating material onto a strip of blackplate or a substrate based on blackplate intended for use in the manufacture of cans and/or can parts, e.g. drawn and wall-ironed cans or deep drawn cans.

Blackplate in this connection means cold rolled, annealed and temper rolled packing steel, usually in the range 0.1 to 0.5 mm thick. Proposals have already been made for manufacturing cans from blackplate coated with a thermosetting resin. For example, US—A—4032678 proposes manufacturing a drawn and wall-ironed can from blackplate coated with a thermosetting resin. The material normally used for such cans is tinplate.

The present applicants have realised, from a techno-economic study, that in order to arrive at an acceptable price for the coated strip, the blackplate should be coated under the following conditions:

1. Because of the high raw material costs of the organic coating material, a thin layer of coating should be applied with a dry coating weight in the range of 1 to 15 g/m<sup>2</sup>, and

2. The blackplate should be coil coated, at a strip speed preferably in the range of 100 to 500 m/min. High strip speeds of this order are found in lines for the electrolytic tinning of blackplate. However, this plating technique is not available for coating with an organic material.

In known lines for coating with an organic material, such as those for coil coating of cold rolled strip, which has a gauge of more than 0.5 mm and is used for various applications e.g. in building construction as façade panels, strip speeds of up to about 100 metres per minute are used. In this case the coating is applied by roller-coating using smooth rolls. During this application with smooth rolls, an application system is used in which the coating material is conveyed by a smooth "licking roll" from a pan, and transferred to the strip by means of a smooth "application roll". Thus smooth, unprepared rolls are used for this coating technique. It has been shown that this application system is unsuitable at a high strip speed.

A method of the kind as mentioned in the preamble is known from US—A—4 378 390. This publication discloses a method of coil coating at a relatively high speed a continuous layer of organic coating material on a strip. In the method a photogravure roll method is used, with a special device for supplying the coating material comprising a nozzle having a slit opening and a pump for pumping the coating material.

The object of the present invention is to solve the problem of coil coating blackplate with an organic material coating layer in a manner which is technically acceptable at the required strip speed and the required layer thickness.

The invention consists in that a screen printing process is used to apply the coating material, e.g. material containing a thermosetting resin, to the strip in a manner such that a continuous coating layer is produced, wherein in the screen printing process the coating material is passed in discrete portions through a plurality of apertures in a screen printing cylinder, and said portions are subsequently united into said continuous layer on the strip, the strip moving past the screen printing apparatus at a speed in the range 20 to 500 metres per minute and the rate of application of the coating material corresponding to a dry coating weight in the range 1 to 15 g/m<sup>2</sup>. The continuous layer may be of even thickness, but predetermined thickness variation may be employed.

Screen printing is known for the printing of strips of paper and textiles with ink or paint, the printing fluid being applied to the strip at spaced-apart regions, e.g. in the form of dots. In known screen printing processes, the printing fluid is forced through perforations or ducts from the inside of a hollow screen printing cylinder and applied onto the strip at locations spaced-apart according to the locations of the ducts.

It is thought surprising to use screen printing for a completely different application, namely the coil coating of blackplate, at high speed and with an extremely low coating weight, with a continuous layer of coating material.

The discrete portions, e.g. small points or dots, of coating material derived from the ducts in the screen printing cylinder are deposited and spread onto the strip, the quantity of coating material being applied to the strip being at least so much that a thin, continuous layer of coating material is obtained. The spaced-apart condition of the small holes of the printing cylinder can no longer be found on the coated blackplate; a coherent coat of coating material is obtained which can be even, i.e. with a substantially constant coating weight.

One major advantage of the use of screen printing for coating blackplate is, as will be explained in greater detail later, that the coating weight of the coating material after application can be almost independent of the strip speed during coating, and of the viscosity of the coating material, so that a product with a constant coating weight is obtained simply. This is apparently a consequence of the small ducts in the screen printing cylinder, by which a kind of volumetric dosing of the coating material is obtained which is largely independent of the strip speed and viscosity of the coating material.

Another advantage, as will also be explained later, is that by using screen printing a coated blackplate with an extremely low coating weight can be obtained.

A further advantage is that the coating can be carried out at an extremely high strip speed.

The layer of coating material can be applied to blackplate from which thereafter drawn and wall-ironed or deep-drawn cans, for example, are to be manufactured. More generally, however, the layer of coating material can also be applied to a substrate of blackplate which, in addition to the blackplate just mentioned,

also comprises blackplate which is provided with a pre-applied layer of another material, which layer forms an intermediate layer after final coating. One example of such a substrate based on blackplate is the coating of ECCS (Electrolytic Chromium Chromium-oxide Steel). Coated ECCS is frequently used for the manufacture of can lids.

5 More generally the coating material can be applied to conversion layers, such as for example a layer of phosphate, and to metal layers, e.g. of tin (Sn), chromium (Cr), nickel (Ni) and iron (Fe), and alloys and combinations thereof.

The coating material applied may be dissolved preferably in an organic solvent, and may also be diluted by means of thinning agent (diluent). The coating material to be applied may also be water-based, the water acting as the carrier of the coating material. In all these cases the solvent/diluent or the water may be driven off by heating the coated blackplate in a furnace, to obtain a dry layer of coating material with a corresponding dry coating weight.

10 The dry coating weight depends on the intended use of the coated blackplate. For drawn and wall-ironed cans, a dry coating weight of 5 g/m<sup>2</sup> or less will be sufficient. For deep-drawn cans, however, where the pre-coat is also the final coat, a dry coating weight of up to 15 g/m<sup>2</sup> may be specified.

15 If the blackplate is coil coated, the coiled strip is brought to a coating line, and there coated upon uncoiling.

The strip speed during coating should preferably be in the range of 100 to 450 m/min, and the dry coating weight of the coat of lacquer should preferably be in the range of 2 to 10 g/m<sup>2</sup>.

20 A smooth applicator roll should preferably be used between the strip and the screen printing cylinder. The small points or blobs of coating material are then first deposited on to the applicator roll by the screen printing cylinder, and may run together (coalesce) to some extent before being transferred to the blackplate.

Screen printing may be used to apply a layer of coating material extending over the entire surface of the strip. The coating material may alternatively be applied in a pattern on the strip surface, in accordance with the parts to be taken from the strip later for the can production. In the latter case the strip surface between the pattern regions may be coated with an extra thin layer of coating material to preserve the strip surface until subsequent processing.

25 Discs, so-called blanks, for example, are taken from the strip thus coated, from which cans or lids for them are manufactured.

Although the strip can be coated on one side only, the strip should preferably be coated on both sides in one operation by screen printing processes in accordance with the invention. In this way coated material is manufactured in an efficient way. The strip can be coated with coating weights which differ on the two sides of the strip, according to the desired coating weight on the inside and outside of the can.

35 The strip may be coated with coating compositions which differ on the two sides of the strip. In this case, the coating composition may differ in the type of coating material, in the quantity of solvent/diluent (thinner) etc.

Embodiments of the invention will now be described with reference to the drawing, in which:—

Figure 1 shows diagrammatically a process for coil coating of blackplate embodying the invention.

40 Figure 2 shows diagrammatically a known roller coating unit.

Figures 3A and 3B show diagrammatically a unit for direct and indirect screen printing respectively, suitable for use in the process illustrated in Figure 1.

Figures 4A to 4D inclusively are graphs of test results obtained in coating processes.

45 In the embodiment of the invention, schematically shown in Figure 1, a cold-rolled steel strip 1 is uncoiled from a coil 2 and fed to at least one screen printing unit 3 and/or 4, by which the strip is coated underneath and/or on top. By heating in a furnace 5, the coating is then dried, the solvent of the coating and the like being removed from the applied layer or layers of coating, and, if a thermosetting coating is used, the coating is cured. Finally the strip 1 is coiled into a coil 6.

50 Figure 2 shows a roller coating unit, known for coating cold-rolled steep strip for applications in civil engineering, comprising a smooth pick-up roll 7 dipping into the coating material in a pan 8. A doctor blade 9 scrapes off excess of coating material picked up by the roll 7. The material is transferred from the pick-up roll 7 to the passing strip 1 by an applicator roll 12. A backing roll 13 is provided on the other side of the strip.

In contrast, the invention employs a screen printing process.

55 The coating unit used in the invention may be a unit for direct screen printing, see Figure 3A, comprising a perforated rotary screen cylinder 10 and a doctor blade 11 within the cylinder for pressing the coating material through the ducts (perforations) onto the strip 1. The material is supplied to the interior of the cylinder.

60 The discrete portions of coating material applied to the strip by the screen printing unit spread out on the strip and run together to coalesce into a continuous and, at least locally, even coating layer which is subsequently dried and possibly cured, as described above.

65 Alternatively, indirect screen printing may be used, see Figure 3B. In this case an applicator roll 12 of a wear resistant synthetic material such as rubber, is suitably arranged between the perforated cylinder 10 and the strip 1. In this screen printing unit, the clots of coating material applied to the surface of the applicator roll spread out before they are applied to the strip, and may partly coalesce on the applicator roll.

## O 195 099

In both cases, the strip is supported by a back-up roll 13 at the location of the coating units.

Two coating units for the two sides may be arranged one behind the other in the direction of strip transport, as shown in Figure 1, but they may alternatively be opposite each other (not shown). In this case the strip is supported by the opposed coating units instead of by back-up rolls.

5 Figure 1 shows diagrammatically a linear strip path; in practice an S-shaped strip path is frequently used in screen printing.

Using a coating line of the type shown in Figure 1, with roller printing and screen printing the following tests were carried out:

- coating by reverse roller coating
- 10 — coating by forward roller coating
- direct coating by means of screen printing
- indirect coating by means of screen printing.

With forward roller coating the strip 1 and applicator roll 12 move in the same direction as shown in Figure 2. With reverse roller coating this relative movement is reversed.

15 The test results are summarised in the following table, giving the strip speed, the weight of the dry layer produced and the viscosity of the coating material.

	Strip speed (m/min)	TABLE Weight of dry coating layer (g/m <sup>2</sup> )	Viscosity DIN diam. 4 (sec.)
	Reverse roller coating		
20	100	5.1	55
25	150	6.9	55
	200	8.0	55
30	250	9.7	55
	100	3.6	32
35	150	4.6	32
	200	5.3	32
	250	6.3	32
40	250	3.8	23
	Forward roller coating		
45	50	3.5	88
	100	4.7	88
	150	6.0	88
50	200	7.1	88
	50	2.0	47
55	100	2.9	47
	150	3.6	47
	200	4.0	47
60	250	5.1	47
	50	1.7	33
	100	2.3	33
65	150	3.0	33

	Strip speed (m/min)	Weight of dry coating layer (g/m <sup>2</sup> )	Viscosity DIN diam. 4 (sec.)
	Direct screen printing		
	20	2.3	50
	50	2.7	50
	100	2.3	50
	150	2.4	50
	Indirect screen printing on blackplate		
	60	4.0	100
	80	3.8	100
	100	4.1	100
	on ECCS		
	60	4.1	100
	80	4.3	100
	100	4.2	100
	100	4.0	50

The test results are reproduced in Figure 4 graphically. In these graphs the strip speed is plotted along the horizontal axis and the coating weight is plotted along the vertical axis.

Figure 4A and 4B present the results of the reverse and forward roller coating. It is apparent that when coating by this method the coating weight increases with both strip speed and viscosity. Variations of coating weight arising from variations of strip speed and viscosity are difficult to control. Complicated, expensive control of the coating system is required. During the tests the pressing forces of the coating application system increased at high speeds. This led to failure of the coating application system at 250 m/min. Even if this difficulty could be eliminated by modifying the design, a range of high coating weights is still encountered at higher speeds. The possibility of obtaining lower coating weights using a low viscosity of the coating material, by adding a thinner, is less attractive because the product is made even more expensive by the additional raw material costs, the energy required for expelling the thinner, and the extra installation required for processing the expelled thinner. Moreover, environmental problems may arise. For the above reasons, therefore, roller coating is not suitable for the application in question, i.e. coating blackplate for can production.

Figure 4C and 4D present the results of direct and indirect screen printing respectively. With this method of coating, a practically horizontally characteristic was found, with a much lower value for the coating weight than with roller coating. The coating weight is almost independent of the strip speed and viscosity of the coating material. By this printing technique, therefore, a coated product is obtained with a high constant coating weight, regardless of strip speed variations and viscosity variations. The value of the coating weight is determined by the dimensions and mesh (pattern) of the ducts in the screen printing cylinder. As shown by the tests, a coating material with a very high viscosity can be used and very low coating weights can be obtained. During the screen printing tests, the maximum speed was only 150 m/min. There were no indications of possible difficulties at higher speeds.

#### Claims

1. Method of coil coating a layer of organic coating material, onto a strip (1) of blackplate or a substrate based on blackplate intended for use in the manufacture of cans and/or can parts, e.g. drawn and wall-ironed cans or deep drawn cans, characterised in that a screen printing process is used to apply the coating material to the strip (1) in a manner such that a continuous coating layer is produced, wherein the screen printing process the coating material is passed in discrete portions through a plurality of apertures in a

screen printing cylinder (10), and said portions are subsequently united into said continuous layer on the strip (1), the strip (1) moving past the screen printing apparatus (3, 4) at a speed in the range 20 to 500 metres per minute and the rate of application of the coating material corresponding to a dry coating weight in the range 1 to 15 g/m<sup>2</sup>.

- 5 2. Method according to claim 1 wherein the coating material comprises a thermosetting resin.
3. Method according to claim 1 or claim 2 wherein a smooth applicator roll (12) transfers the coating material from a screen printing cylinder (10) on to the strip (1).
4. Method according to claim 3 wherein the unification of the said discrete portions takes place at least partly on said applicator roll (12).
- 10 5. Method according to any one of the preceding claims wherein the coating layer is of even thickness.
6. Method according to any one of the preceding claims wherein the strip speed relative to the screen printing apparatus (3, 4) coating is in the range 100 to 450 metres per minute and the said dry coating weight is in the range 2 to 10 g/m<sup>2</sup>.
7. Method according to any one of the preceding claims wherein the strip (1) is coated on both sides in one operation.
- 15 8. Method according to claim 7 wherein the strip (1) is coated with different coating weights on both sides of the strip (1).
9. Method according to claim 7 or claim 8 wherein the strip (1) is coated with different coating compositions on both sides of the strip (1).

#### 20 Patentansprüche

1. Verfahren zum Bandbeschichten einer Schicht organischen Beschichtungsmaterials auf ein Band (1) aus Schwarzblech oder einem Substrat auf Schwarzblechbasis zur Verwendung in der Herstellung von Dosen und/oder Dosenteilen, z.B. gezogene und wand-abgestreckte Dosen oder tiefgezogene Dosen, dadurch gekennzeichnet, daß zum Aufbringen des Beschichtungsmaterials auf das Band (1) ein Siebdruckverfahren in einer Weise so verwendet wird, daß eine kontinuierliche Überzugsschicht erzeugt wird, wobei beim Siebdruckverfahren das Beschichtungsmaterial in diskreten Portionen durch eine Vielzahl von Öffnungen in einem Siebdruckzylinder (10) geleitet wird und diese Portionen nachfolgend in diese kontinuierliche Schicht auf dem Band (1) vereinigt werden, wobei sich das Band (1) mit einer Geschwindigkeit im Bereich von 20 bis 500 Metern pro Minute an der Siebdruckvorrichtung (3, 4) vorbeibewegt und die Auftragstrate des Beschichtungsmaterials einem trockenen Überzugsgewicht im Bereich von 1 bis 15 g/m<sup>2</sup> entspricht.
2. Verfahren gemäß Anspruch 1, wobei das Beschichtungsmaterial ein wärmehärtendes Harz enthält.
- 35 3. Verfahren gemäß Anspruch 1 oder Anspruch 2, wobei eine glatte Auftragswalze (12) das Beschichtungsmaterial vom Siebdruckzylinder (10) auf das Band (1) überträgt.
4. Verfahren gemäß Anspruch 3, wobei die Vereinigung der diskreten Portionen zumindest teilweise auf der Auftragswalze (12) stattfindet.
5. Verfahren gemäß irgendeinem der vorhergehenden Ansprüche, wobei die Überzugsschicht von gleichmäßiger Dicke ist.
- 40 6. Verfahren gemäß irgendeinem der vorhergehenden Ansprüche, wobei die Bandgeschwindigkeit gegenüber der Siebdruckvorrichtung (3, 4) während des Beschichtens in Bereich von 100 bis 450 Meter pro Minute und das trockene Überzugsgewicht im Bereich von 2 bis 10 g/m<sup>2</sup> liegen.
7. Verfahren gemäß irgendeinem der vorhergehenden Ansprüche, wobei das Band (1) in einem Arbeitsgang auf beiden Seiten beschichtet wird.
- 45 8. Verfahren gemäß Anspruch 7, wobei das Band (1) auf beiden Seiten des Bandes (1) mit verschiedenen Überzugsgewichten beschichtet wird.
9. Verfahren gemäß Anspruch 7 oder Anspruch 8, wobei das Band (1) mit verschiedenen Überzugszusammensetzungen auf beiden Seiten des Bandes (1) beschichtet wird.

#### 50 Revendications

1. Procédé de revêtement sur bobine au moyen d'une couche de matériau de revêtement organique, appliqué sur une bande (1) de tôle noire, ou sur un substrat à base de tôle noire, destinée à être utilisée dans la fabrication de boîtes et/ou de parties de boîtes, par exemple des boîtes embouties et comportant des parois en fer, ou des boîtes obtenues par emboutissage profond, caractérisé en ce qu'on utilise un procédé d'impression par écran pour appliquer le matériau de revêtement sur la bande (1) d'une façon telle qu'on crée une couche de revêtement continue, dans lequel procédé d'impression par écran on fait passer le matériau de revêtement par parties discrètes à travers une pluralité d'ouvertures d'un cylindre (10) d'impression par écran, et lesdites parties sont consécutivement réunies pour former ladite couche continue sur la bande (1), la bande (1) se déplaçant dans l'appareil (3, 4) d'impression par écran à une vitesse de l'ordre de 20 à 500 mètres par minute et le taux d'application du matériau de revêtement correspondant à un poids de revêtement sec de l'ordre de 1 à 15 g/m<sup>2</sup>.
- 65 2. Procédé selon la revendication 1, dans lequel le matériau de revêtement comprend une résine thermodurcissable.

## 0 195 099

3. Procédé selon la revendication 1 ou la revendication 2, dans lequel un rouleau (12) applicateur lisse transfère le matériau de revêtement d'un cylindre (10) d'impression par écran sur la bande (1).

4. Procédé selon la revendication 3, dans lequel l'unification desdites parties discrètes s'effectue au moins partiellement sur ledit rouleau (12) applicateur.

5 5. Procédé selon l'une quelconque des revendications précédentes, dans lequel la couche de revêtement est d'épaisseur égale.

6. Procédé selon l'une quelconque des revendications précédentes dans lequel la vitesse de la bande par rapport à l'appareil (3, 4) d'impression par écran est de l'ordre de 100 à 450 mètres par minute et le poids du revêtement sec est de l'ordre de 2 à 10 g/m<sup>2</sup>.

10 7. Procédé selon l'une des revendications précédentes, dans lequel la bande (1) est revêtue des deux côtés en une seule opération.

8. Procédé selon la revendication 7 dans lequel la bande (1) est revêtue avec des poids de revêtements différents sur les deux côtés de la bande (1).

15 9. Procédé selon la revendication 7 ou la revendication 8, dans lequel la bande (1) est revêtue avec des compositions de revêtement différentes sur les deux côtés de la bande (1).

20

25

30

35

40

45

50

55

60

65

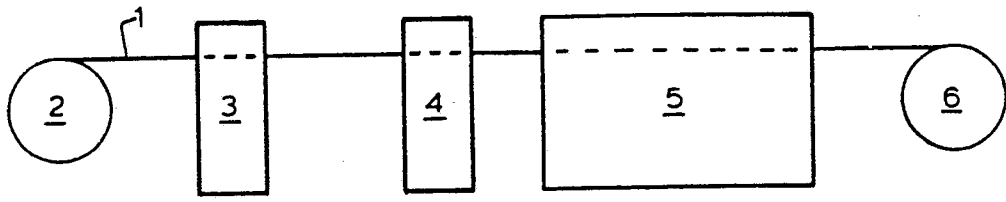

fig. 1

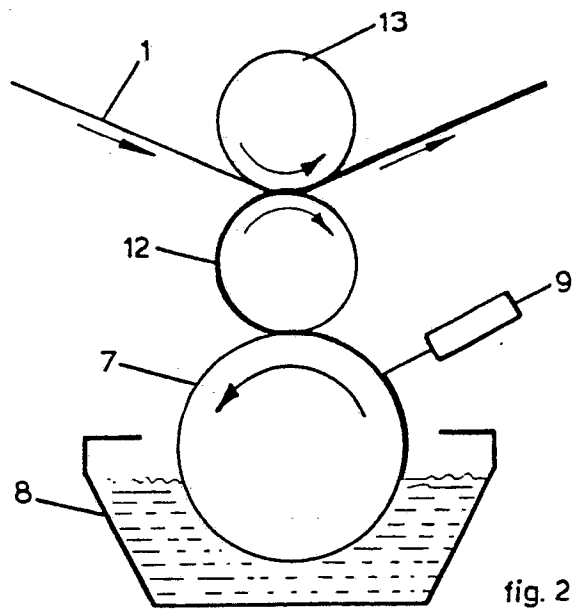

fig. 2

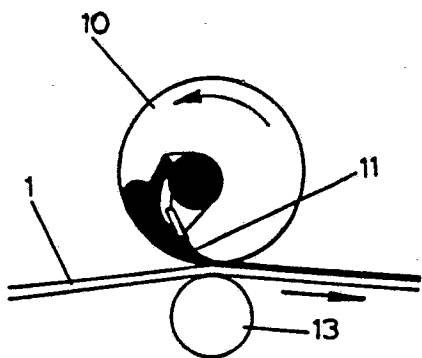

fig. 3 A

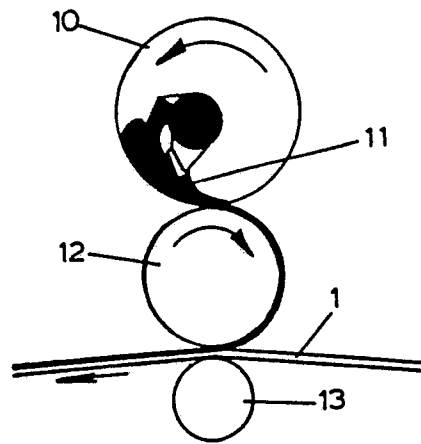

fig. 3 B

