



Europäisches Patentamt  
European Patent Office  
Office européen des brevets

⑪ Publication number:

**0 196 799  
B1**

⑫

## EUROPEAN PATENT SPECIFICATION

④⑤ Date of publication of patent specification: **25.05.88**

⑤① Int. Cl.<sup>4</sup>: **B 65 B 9/04**

②① Application number: **86301633.3**

②② Date of filing: **07.03.86**

⑤④ Improvements in or relating to packaging.

③⑩ Priority: **11.03.85 GB 8506246**

④③ Date of publication of application:  
**08.10.86 Bulletin 86/41**

④⑤ Publication of the grant of the patent:  
**25.05.88 Bulletin 88/21**

⑧④ Designated Contracting States:  
**AT BE CH DE FR GB IT LI LU NL SE**

⑤⑥ References cited:  
**DE-B-1 118 090  
FR-A-2 171 705  
GB-A-1 401 471**

⑦③ Proprietor: **BUNZL FLEXPACK LIMITED**  
**Bridge Hall Mills**  
**Bury Lancashire BL9 7 PA (GB)**  
⑦③ Proprietor: **KEYES FIBRE COMPANY**  
**College Avenue**  
**Waterville Maine (US)**

⑦② Inventor: **Baden Fuller, Anthony Thomas**  
**The Mount Austenwood Lane**  
**Gerrards Cross Buckinghamshire (GB)**  
Inventor: **Jones, Arthur Neville**  
**Blackthorn Wilton Lane**  
**Jordans Buckinghamshire (GB)**  
Inventor: **Ferrar, Andrew Nicholas**  
**354 Chorley New Road**  
**Bolton Lancashire BL1 5AD (GB)**

⑦④ Representative: **Thiemann, Peter Albert William**  
**et al**  
**LLOYD WISE, TREGEAR & CO. Norman House**  
**105-109 Strand**  
**London WC2R 0AE (GB)**

Note: Within nine months from the publication of the mention of the grant of the European patent, any person may give notice to the European Patent Office of opposition to the European patent granted. Notice of opposition shall be filed in a written reasoned statement. It shall not be deemed to have been filed until the opposition fee has been paid. (Art. 99(1) European patent convention).

**EP 0 196 799 B1**

## Description

This invention relates to packaging and is concerned with an improved method for automatically packaging articles such as fresh and frozen, raw or prepared foods, such as meat, fish, cheese, bakery products, fruit and vegetables, as well as for packaging sterile or sterilisable articles for hospital and other use.

In one method of packaging, e.g. fresh meat, carried out on an automatic system, a web of relatively thick plastics material such as a polyvinylchloride/polyethylene layer is thermoformed to make containers in the form of trays or the like to receive the articles to be packaged. Preferably, the containers are formed in a grid pattern. The containers are then filled, as with fresh meat portions or meat products and a web or film of plastics material is fed on to the containers from above. The containers are then sealed by a form of packaging known as "modified atmosphere packaging" in which the atmosphere in contact with the contents of the containers is controlled as, for example, to its oxygen content, although, in fact, for packaging some articles no actual modification of the atmosphere is required, while in other cases modification of the atmosphere present in the package may occur during storage by reaction with the product being stored. The containers may then be separated by cutting.

By virtue of the properties which the resulting package is required to have, the range of materials which can be utilized to form the package is limited. In practice, only thick laminates of unplasticised polyvinyl chloride and polyethylene have been used to form the base component of the package. The base components are prepared by thermo-forming to yield deep tray-like structures which are subsequently closed by heat-sealing a membrane around the peripheral lip of the base component to contain within the package a product and an appropriate gas mixture. The thick polyvinyl chloride (PVC) ply of the laminate is employed to provide the package with gas-impermeability and to impart physical rigidity to the finished closed package and to ensure that the package is substantially gas-tight.

As just indicated, in order to be gas-impermeable and sufficiently rigid, the polyvinylchloride has to be relatively thick. While it is theoretically possible to heat seal a lid of similar PVC, to a container of the material, difficulties arise in practice and it is preferable to use an adhesive or hot melt adhesive bond to join the lid to the container. However, such containers of thick PVC are too expensive to be a viable commercial proposition.

If an attempt is made to use thinner material two problems arise. Firstly, if a plastics container is to have sufficient rigidity for the required purpose, it is a fact that the side walls of the container must be vertical otherwise the container is unacceptably floppy. Since most shallow plastics containers are formed by deep-drawing

techniques, either by pressure or vacuum-forming, an unacceptable thinning of the material occurs at the corners. Thus, for example, a sheet of plastics material 0.5 mm. thick when drawn down to form a shallow tray may have a base of about 0.375 mm. thick but may have a thickness at the corners of 0.160 to 0.125 mm. At this thickness the material is very vulnerable to rupture or damage.

Secondly, as the material is made thinner, it loses its gas-imperviousness and in order to reinstate this property it becomes necessary either to use a thicker sheet of plastics or to line the container with a gas-impervious layer. However, the problems of thinning at the corners are also encountered if a gas impervious layer is applied by deep drawing techniques.

Because of the specialized nature of the package material and the bulk of the container, the modified atmosphere packaging process is limited to large scale factory operations employing expensive and complex packaging equipment using rolls of laminate material for forming the base components, which rolls have to be of large diameter if the process is to be economically feasible. Accordingly, the process can only be made use of by a few of the largest packers or processing companies.

This packaging method, however, has several disadvantages. Because the material of which the containers is formed is relatively thick, reels of the material have to be replaced frequently with possible consequent stopping of the production line and substantial wastage of scrap material.

According to the present invention there is provided a method of packaging articles, wherein a plurality of joined, substantially gas-impermeable containers for the articles are fed to a loading station at which the articles are placed in the containers, and wherein the containers are then closed by bonding a web of plastics lidding material to the edges of the containers, at a thermo-sealing station, thereby to enclose the articles in the containers with a lid of said plastics material characterised in that the said plurality of containers to be fed to the loading station is formed from a plurality of substantially rigid, preformed individual containers of porous material which are fed on conveyor means below a web of plastics lining material which is substantially gas-impermeable and which is united with and bonded to the interior of the containers by a thermo-forming operation, thereby to provide the porous containers with a coherently bonded substantially gas-impermeable lining and to connect the containers one with another.

With this method, the plastics material used to line the preformed containers is preferably a multilayer film having a gas-permeable layer and a thermoplastic layer and is very much thinner than the material of which the containers were thermo-formed in the prior process. Therefore, less reel changes are needed and a faster cycle time can be effected due to the use of thinner material in the thermo-forming stage. Further-

more, the cutting mechanism for separating the sealed containers into individual packages can be of lighter construction as it may need to cut only through two thin films of plastics.

The containers are preferably formed of porous fibrous material such as moulded fibre pulp, paper, cardboard or fibre board made in conventional manner by moulding fibres deposited by paper-making techniques. Alternatively, the containers may be made from bonded wood chips, bonded fibre material or other suitable gas-previous membranes. The containers may also be formed from foamed open-cell or fibrous structures of plastics which may contain fillers. It is necessary that the material of which the containers are made should be rigid and porous and have at its surface interstices into which the thermoplastic layer of the multi-layer lining film can be coherently bonded.

An advantage of the container used in the present method is that it is easier to make unusual shapes by moulding than by vacuum forming so the present method particularly lends itself to packaging unusual shaped products by adapting the package to the product in an economical manner.

Other advantages which the present method provides over the previously proposed method in which the trays are thermoformed from relatively thick PVC, lie not only in the flexibility of the present method but in the substantial and unexpected economic advantages which arise. The cost of moulded fibre trays is considerably less than the cost of the relatively thick PVC for trays of an equivalent rigidity, and, as indicated, it is easier to provide moulded fibre trays of complex shape and uniform thickness than by thermo-forming plastics material.

Because the reel is made of thin lining material rather than relatively thick material which has to be thermoformed, the intervals between reel changes are considerably increased and since a reel change requires the plant to stop, the output of the present method is increased and the amount of scrap produced is decreased. Indeed an increase of 8 to 10% in output has been observed with the present method as compared with the previously proposed method. This increase is assisted by the fact that there need never be any interruption in the feeding of the trays on. Furthermore, because the thermo-forming station 5 is dealing with thin material, rather than thick material, the time for heating the material and bonding it to the tray is less than the time required to heat and thermoform the thicker material. In this context, an increase in output of up to 25% has been observed as compared with the previously proposed method. Also as the plant is, in general, dealing with thinner and lighter material than the relatively thick PVC, the tooling and maintenance costs are reduced. Finally, the present method is very suitable for use with lining and/or lidding materials comprising polyesters as these will be in thin layers which are very much more easy to process than thick polyester layers.

The sealing is effected using a lid or closing membrane which may be a multilayer film having a gas-impermeable layer and a thermoplastic layer.

If the product to be package is, for example, meat or fish, it is highly desirable that a prospective purchaser should be able to inspect the contents, it is therefore desirable for the lid or closing membrane to have an antifog inner surface adjacent the gas-tight space, so that the lid does not become obscured by condensation of water from the product upon changes in temperature occurring.

The plastics film used to line the preformed containers may comprise a single layer of thermoplastic plastics, such as polypropylene, or a layer of plastics material such as a polyester, for example, polyethyleneterephthalate, or an amide, such as nylon, with a layer of thermoplastic adhesive whereby the liner can be adhered to the container.

However, and as indicated above, the plastics film used to line the preformed containers is preferably a multilayer film at least some of the layers of which are thermoplastic.

The multilayer film may comprise any desired number of layers required to give the film the necessary thermoplasticity and gas-impermeability. Preferably, the film bonded to the container is a multilayer film comprising at least three layers, namely a first layer capable of bonding strongly to the surface of the porous container to give a bond at least equal to the inherent mechanical strength thereof, a central layer of gas-impermeable polymeric material, and a third layer of polymeric material capable of bonding to the thermoplastic material of the lid or closing membrane.

Conveniently, the multilayer thermoplastic film comprises an ionomeric polymeric material, such as that known under the Registered Trade Mark "SURLYN", as said first and third layers, and the gas-impermeable layer may be of polyvinylidene chloride, polyvinyl alcohol or an ethylene/vinyl acetate copolymer which may be partly hydrolysed.

The lid or closing membrane may be made of a similar material to the lining material and preferably has a higher melting or softening point than the inner ionomeric layer.

In order to enable the invention to be more readily understood reference will now be made to the accompanying drawings which illustrate diagrammatically and by way of example an embodiment thereof, and in which:—

FIGURE 1 shows plant for packaging articles by the method of the present invention, and

FIGURE 2 is a partly exploded section through a package produced by the plant shown in Figure 1.

Referring now to Figure 1, there is shown plant in which packages of fresh meat are to be formed on a vacuum packaging-gas flush machine, such as a machine of the type described in United States Patent US—A—3,956,867 to Kastulus Utz et al. Preformed containers in the form of trays 1 of porous fibre material such as paper, cardboard,

fibre board, pulp fibre, wood or fibre chips of foamed plastics material, preferably of moulded pulp fibre, are taken from a stack or stacks 1 of trays by destacking apparatus indicated by arrow 3 and placed in rows across a conveyor 4 so as to form a closely spaced array of trays on the conveyor. The trays 1 are fed by the conveyor to a thermo-forming station 5. A reel 6 of thin plastics material 7, such as a film comprising a layer of polyvinylidene chloride sandwiched between two layers of ionomeric polymeric material and having a total thickness of 100 to 150 microns, is mounted above the conveyor 4 and the film is united with the trays 1 at the thermo-forming station 5 so as to line the containers with the film and unite the containers. The film is coherently bonded to the container by being heated by a heater 8 and by being drawn downwardly by a vacuum applied at a vacuum outlet 9. The film is drawn into the interstices of the porous substrate so that the polyvinylidene chloride layer is rigidly adhered to the tray. By this means the gas impermeable polyvinylidene chloride layer is rigidly adhered to the tray in such a way as to prevent it from becoming detached and consequently damaged with the resulting deterioration or spoiling of the contents of the package.

After leaving the thermo-forming station 5 the trays are passed to a loading station 10 where they are filled in turn with the meat product 11 to be packed. A lidding material 12 in the form of an inextensible composite web is unwound from a feed roll 14 located above the flow path of the trays and brought to cover them. The two webs are then combined in a vacuum chamber of the vacuum packaging-gas flush machine 15 so that the mouth of the tray is covered by and heat-sealed to the composite web 12 using a heated sealing plate 16 and by appropriate control of the atmosphere and pressure in the chamber and the package as known in the art using appropriate gas and vacuum inlets and outlets generally indicated at 17 and 18.

The containers leaving the chamber are separated by a knife 19 into individual packages 20 which may be subject to edge trimming.

It will be appreciated that modifications of the present process are possible and the preparation of the lined containers may take place elsewhere, the prepared containers being fed directly to the vacuum chamber.

Referring now to Figure 2, the package 20 is shown in greater detail and comprises the porous rigid flanged tray 1, lined with the lining material 7. The lining material 7 comprises a gas-impermeable layer 21 sandwiched between two layers 22 and 23 of ionic polymeric material such as that known under the Registered Trade Mark "SURLYN". The layer 22 adjacent the tray 1 has been softened and drawn into the interstices of the tray so that it is coherently bonded to the tray and thus bonds the lining material to the tray.

The lidding material 12 is also formed of three layers bonded together to give a united structure which is flexible. The layer 24 which will form the

interior of the package is of an ionic polymeric material similar to or the same as that of which the layer 23 is made so that the layers 23 and 24 can be united with one another by a heat-sealing, welding or other bonding operation in the machine 15. The middle layer 25 is, like the layer 21, gas-impermeable and the outer layer 26 is a support layer which has a substantially higher melting point than either of layers 24 and 25 so that it can withstand a heat-sealing or like operation whereby the layers 23 and 24 are united at the edges of the tray 1.

It is to be appreciated that the material of which the tray 1 is made should be capable of being cohesively bonded to and wetted by the polymer of the layer 22 when the polymer is applied at elevated temperature to the surface of the tray.

As indicated above, the layers 22, 23 and 24 are made of an ionomeric polymer, that is to say a polymer of that class of polymers in which ionised carboxyl groups create ionic cross-links in the molecular structure, which links are reversibly broken at melt temperatures. The layers 22, 23 and 24 may all conveniently be made of the same material, such as that sold under the Registered Trade Mark "SURLYN". In order to ensure adequate bonding of the ionomeric polymer to the moulded porous tray 1, the layer 22 may be thicker than the other two layers. The layer 21 of gas-impermeable material is preferably a film of polyvinylidene chloride or a copolymer thereof. Alternatively, the gas-impermeable layer 21 may be a polyvinyl alcohol or a copolymer of ethylene and vinyl acetate which may have undergone a degree of hydrolysis.

As indicated above, the layer 24 of the lidding material 12 is of an ionomeric polymer material similar to the material from which the layer 23 is made, and the layer 24 must be heat-sealable or weldable to the layer 23. It is a preferred feature of the layer 24 that the surface of this layer in contact with the gaseous atmosphere in the space within the package shall be hydrophilic so that, when the resulting package is in use, a continuous transparent film of water can form on the surface of the layer 24 so as to maintain the visibility of the contents of the package. The lidding material of the final package thus has an antifog inner surface adjacent the space containing the contents of the package. The layer 24 can be made hydrophilic in conventional manner as by incorporation of a surfactant into or onto the layer.

If desired, the layers 23 and 24 can be pigmented white or other desired colour to give an enhanced appeal to the subsequent package.

The middle layer 25 of the lidding material is impermeable to gases, such as oxygen and, like the layer 21, may be a vinylidene chloride polymer or copolymer or a vinyl alcohol polymer or a copolymer of ethylene and vinyl acetate which may be partly hydrolysed.

The outmost layer 26 of the lidding material 12 is one which has a substantially higher melting point than either of the layers 24 and 25 so that heat-sealing of the layers 23 and 24 can be

5

10

15

20

25

30

35

40

45

50

55

60

65

effected by heat transmitted through the layers 26 and 25. The layer 26 is conveniently a film of a polyester or polyamide.

If desired, the tray 1 may be formed with cut-outs separated by bars or by cruciform members. The cut outs are bridged by the lining material 7 and it will be appreciated that this arrangement allows the contents of the package to be inspected from underneath. In this case it may be desired to make the inner-surface of the layer 23 hydrophilic also.

The invention will now be further illustrated by the following Example.

#### EXAMPLE

Stacks of moulded pulp fibre trays sold under the Registered Trade Mark "SHOPAK" by Keyes Fibre Company are fed by a de-nesting apparatus onto a conveyor belt so that a plurality of trays is laid across the belt in rows along the belt. The belt is passed to a thermoforming station together with a first web of plastics material for lining the trays by a vacuum-forming technique. The web, as shown in Figure 2, comprises a layer 22 of an ionomeric polymer sold under the Registered Trade Mark "SURLYN" and of a thickness of 75 microns. The layer 23 is of the same material but is only 40 microns thick. The layer 21 between the layers 22 and 23 is a coating of polyvinylidene chloride applied to the layer 21 at a rate of 5 g. per m<sup>2</sup> and adhesively bonded to the layer 22.

A food product to be packaged is then placed in the space in the container and the lidding material 12 is applied on top of the package and heat-sealed thereto after the atmosphere in the space has been controlled to the desired composition. The material 12 comprises a layer 24 of the same material as the layers 22 and 23 but of 40 micron thickness. The layer 25 comprises a coating of polyvinylidene chloride applied at a rate of 3 g. per m<sup>2</sup> to the layer 24 and adhesively bonded to the layer 26 which comprises a layer of polyester 12.5 micron thick.

The packaging of the food products is suitably conducted in a conventional packaging machine in which the atmosphere inside the space is controlled, the choice of gas composition depending upon the particular food product being packaged. Mixtures of carbon dioxide and oxygen are generally used for packaging red meat and mixtures of nitrogen and carbon dioxide are used for packaging fish products.

#### Claims

1. A method of packaging articles, wherein a plurality of joined, substantially gas-impermeable containers for the articles is fed to a loading station (10) at which the articles (11) are placed in the containers, and wherein the containers are then closed by bonding a web of plastics lidding material (12) to the edges of the containers, at a thermo-sealing station (15), thereby to enclose the articles in the containers with a lid of said plastics material characterised in that: the said

plurality of containers to be fed to the loading station (10) is formed from a plurality of substantially rigid, preformed individual containers (1) of porous material which are fed on conveyor means (4) below a web of plastics lining material (7) which is substantially gas-impermeable and which is united with and bonded to the interior of the containers (1) by a thermo-forming operation, thereby to provide the porous containers (1) with a coherently bonded substantially gas-impermeable lining and to connect the containers one with another.

2. A method as claimed in Claim 1, wherein the plastics lining material (7) is a multilayer thermoplastic film at least one of the layers of which is preferably pigmented.

3. A method as claimed in Claim 2, wherein the multilayer thermoplastic film (7) bonded to the containers comprises at least three layers, namely a first layer (22) capable of bonding strongly to the surface of the porous containers to give a bond at least equal to the inherent mechanical strength thereof, a central layer (21) of gas-impermeable polymeric material, and a third layer (23) of polymeric material capable of bonding to the web of plastics lidding material (12) to form the lid of the containers.

4. A method as claimed in Claim 3, wherein the multilayer thermoplastic film comprises an ionomeric polymeric material as said first and third layers (22, 23), and wherein the gas-impermeable layer (21) is of polyvinylidene chloride, polyvinyl alcohol or an ethylene/vinyl acetate copolymer which may be partly hydrolysed.

5. A method as claimed any one of Claims 1 to 5, wherein the web of plastics lidding material (12) comprises at least three layers, namely a first layer (24) capable of bonding to the plastics lining material bonded to the tray, a central layer (25) of gas-impermeable polymeric material and a third layer (26) of polymeric material having a melting or softening point higher than that of said first layer.

6. A method as claimed in Claim 5, wherein the web of plastics lidding material (12) comprises an ionomeric polymeric material as said first layer (24) and a polyester or polyamide as said third layer (26), and wherein the gas-impermeable layer (25) is of polyvinylidene chloride, polyvinyl alcohol or an ethylene/vinyl acetate copolymer which may be partly hydrolysed.

7. A method as claimed in any one of Claims 1 to 6, wherein the second web of plastics material (12) has an anti-fog surface adjacent the space within the package.

8. A method as claimed in any one of Claims 1 to 7, wherein the porous tray (1) is made of paper, cardboard, fibre board, pulp fibre, wood or fibre chips or foamed plastics material, preferably moulded pulp fibre.

9. A method as claimed in any one of Claims 1 to 8, wherein the web of plastics lining material (7) is in contact with and coherently bonded to the inner surface of said containers by a vacuum-

forming technique at a thermo-forming station (5).

10. A method as claimed in any one of Claims 1 to 9, wherein the containers are sealed using a modified atmosphere packaging technique at said thermo-sealing station (15).

#### Patentansprüche

1. Verfahren zum Verpacken von Gegenständen, bei dem eine Vielzahl von verbundenen, im wesentlichen gasundurchlässigen Behältern für die Gegenstände zu einer Beladestation (10), geführt wird, bei der die Gegenstände (11) in die Behälter gelegt werden und die Behälter anschließend verschlossen werden, indem eine Folie aus Kunststoff-Deck-Material (12) mit den Rändern der Behälter bei einer Heißsiegelstation (15) verschweißt wird, wodurch die Gegenstände in den Behältern mit einem Deckel aus dem genannten Kunststoff-Material eingeschlossen werden, dadurch gekennzeichnet, daß die genannte Vielzahl von Behältern, die zu der Beladestation (10) transportiert wird, aus einer Vielzahl von im wesentlichen starren, vorgeformten einzelnen Behältern (1) aus porösem Material gebildet ist, die auf einer Fördervorrichtung (4) unterhalb einer Folie aus Kunststoff-Auskleidungs-Material (7) transportiert werden, die im wesentlichen gasundurchlässig ist und die mit dem Inneren der Behälter (1) durch ein Thermoformverfahren verbunden wird, wobei hierdurch die porösen Behälter (1) mit einer zusammenhängend verbundenen, im wesentlichen gasundurchlässigen Auskleidung versehen und miteinander verbunden werden.

2. Verfahren nach Anspruch 1, dadurch gekennzeichnet, daß das Kunststoff-Auskleidungs-Material (7) ein mehrelagiger, thermoplastischer Film ist, bei dem wenigstens eine der Folienlagen vorzugsweise pigmentiert ist.

3. Verfahren nach Anspruch 2, dadurch gekennzeichnet, daß der mehrlagige thermoplastische Film (7), der mit den Behältern verbunden ist, wenigstens drei Lagen umfaßt, nämlich eine erste Lage (22), die fest mit der Oberfläche der porösen Behälter verbindbar ist, um eine Verbindung mit einer Haftung herzustellen, die wenigstens gleich der dem Material innewohnenden Zugfestigkeit ist, eine mittlere Folienlage (21) aus gasundurchlässigem polymeren Material und eine dritte Folienlage (23) aus polymerem Material, das in der Lage ist, sich mit der Folie des Kunststoff-Deck-Materials (12) zu verbinden, das den Deckel der Behälter bilden soll.

4. Verfahren nach Anspruch 3, dadurch gekennzeichnet, daß der mehrlagige thermoplastische Film ein ionomeres, polymeres Material, wie die genannte erste und dritte Folienlage (22, 23) umfaßt, und daß die gasundurchlässige Lage (21) aus Polyvinyliden-Chlorid, Polyvinylalkohol oder aus einem Ethylen-Vinylacetat-Copolymer besteht, die teilweise hydrolysiert sein können.

5. Verfahren nach einem der Ansprüche 1 bis 4, dadurch gekennzeichnet, daß die Folie des Kunst-

stoff-Deck-Materials (12) wenigstens drei Folienlagen umfaßt, nämlich eine erste Folienlage (24), die mit dem Kunststoff-Auskleidungs-Material verbindbar ist, das mit dem Behälter verbunden ist, eine mittlere Folienlage (25) aus gasundurchlässigem polymeren Material und eine dritte Folienlage (26) aus polymerem Material, das einen Schmelzoder Erweichungspunkt besitzt, der höher liegt als der der genannten ersten Folienlage.

6. Verfahren nach Anspruch 1, dadurch gekennzeichnet, daß die Folie aus Kunststoff-Deck-Material (12) ein ionomeres, polymeres Material, wie die genannte erste Folienlage (24), und ein Polyester oder Polyamid, wie die dritte Folienlage (26), umfaßt und daß die gasundurchlässige Folienlage (25) aus Polyvinyliden-Chlorid, Polyvinylalkohol oder aus einem Ethylen-Vinylacetat-Copolymer besteht, die teilweise hydrolysiert sein können.

7. Verfahren nach einem der Ansprüche 1 bis 6, dadurch gekennzeichnet, daß die zweite Folie aus Kunststoff-Materials (12) eine Antibeschlag-Ausrüstung auf der Seite besitzt, die zum Verpackensinneren ausgerichtet ist.

8. Verfahren nach einem der Ansprüche 1 bis 7, dadurch gekennzeichnet, daß der poröse Behälter (1) aus Papier, Pappe, Faserstoffmaterial, Zellstoffasern, Holzspänen, Faserspänen oder aus geschäumtem Kunststoff-Material, vorzugsweise aus formgepreßten Zellstoffasern, hergestellt ist.

9. Verfahren nach einem der Ansprüche 1 bis 8, dadurch gekennzeichnet, daß die Folie aus Kunststoff-Auskleidungs-Material (7) mit der inneren Oberfläche der genannten Behälter durch Vakuum-Formtechnik in einer Thermoformstation (5) in Kontakt gebracht und zusammenhängend damit verbunden wird.

10. Verfahren nach einem der Ansprüche 1 bis 6, dadurch gekennzeichnet, daß die Behälter unter Anwendung einer Technik einer modifizierten Atmosphäre in der genannten Thermoformstation (15) versiegelt werden.

#### Revendications

1. Une méthode d'emballage des articles selon laquelle une pluralité de conteneurs jointifs substantiellement imperméables aux gaz pour les articles est alimentée dans un poste de chargement (10) auquel les articles (11) sont placés dans les conteneurs, et selon laquelle conteneurs sont ensuite fermés par liaison d'une nappe de matière plastique pour couvercle (12) sur les bords des conteneurs, dans un poste de thermo-scelllement (15) afin d'enfermer les articles dans les conteneurs à l'aide d'un couvercle en cette matière plastique, caractérisée en ce que la pluralité de conteneurs à alimenter dans le poste de chargement (10) est formée d'une pluralité de conteneurs individuels préformés substantiellement rigides (1) en matériau poreux, qui sont alimentés sur un convoyeur (4) au-dessous d'une nappe de matière plastique de doublure (7) qui est substantiellement imperméable aux gaz et qui est réunie

et liée à l'intérieur des conteneurs (1) par une opération de thermoformage, afin de former des conteneurs poreux (1) avec une doublure substantiellement imperméable aux gaz liée de manière cohérente et pour relier les conteneurs les uns avec les autres.

2. Une méthode selon la revendication 1, selon laquelle la matière plastique de doublure (7) est un film thermoplastique à couches multiples dont l'une au moins des couches est de préférence pigmentée.

3. Une méthode selon la revendication 2, selon laquelle le film thermoplastique à couches multiples (7) lié aux conteneurs comprend au moins trois couches, à savoir une première couche (22) susceptible de se lier fortement à la surface des conteneurs poreux pour donner une liaison au moins égale à sa résistance mécanique inhérente, une couche centrale (21) en matière polymère imperméable aux gaz et une troisième couche (23) de matière polymère susceptible de se lier à la nappe de matière plastique pour couvercle (12) pour former le couvercle des conteneurs.

4. Une méthode selon la revendication 3, selon laquelle le film thermoplastique à couches multiples comprend une matière polymère ionomère constituant lesdites première et troisième couches (22, 23), tandis que la couche imperméable aux gaz (21) est du chlorure de polyvinylidène, de l'alcool polyvinylique ou un copolymère d'éthylène/acétate de vinyle qui peut être partiellement hydrolysé.

5. Une méthode selon l'une des revendications 1 à 4, selon laquelle la nappe de matière plastique pour couvercle (12) comprend au moins trois couches, à savoir une première couche (24) susceptible de se lier à la matière plastique de doublure liée au plateau, une couche centrale (25)

de matière polymère imperméable aux gaz et une troisième couche (26) de matière polymère ayant un point de fusion ou de ramollissement supérieur à celui de ladite première couche.

5 6. Une méthode selon la revendication 6, selon laquelle la nappe de matière plastique pour couvercle (12) comprend une matière polymère ionomère constituant la première couche (24) et un polyester ou un polyamide constituant la troisième couche (26), tandis que la couche imperméable aux gaz (25) est un chlorure de polyvinylidène, en alcool polyvinylique ou en ou copolymère d'éthylène/acétate de vinyle qui peut être partiellement hydrolysé.

10 7. Une méthode selon l'une quelconque des revendications 1 à 6, selon laquelle la seconde nappe de matière plastique (12) a une surface antibuée adjacente à l'espace intérieur de l'emballage.

15 8. Une méthode selon l'une quelconque des revendications 1 à 7, selon laquelle le plateau poreux (1) est en papier, carton, carton cuir, fibres de pâte, copeaux de bois ou de fibres ou en une matière plastique mousse, de préférence en fibres de pâte moulées.

20 9. Une méthode selon l'une quelconque des revendications 1 à 8, selon laquelle la nappe de matière plastique de doublure (7) est en contact avec et est liée de manière cohérente à la surface interne desdits conteneurs à une technique de formage sous vide dans un poste de thermoformage (5).

25 10. Une méthode selon l'une quelconque des revendications 1 à 9, selon laquelle les conteneurs sont scellés en utilisant une technique d'emballage à atmosphère modifiée dans le poste de thermo-scellement (15).

40

45

50

55

60

65

7

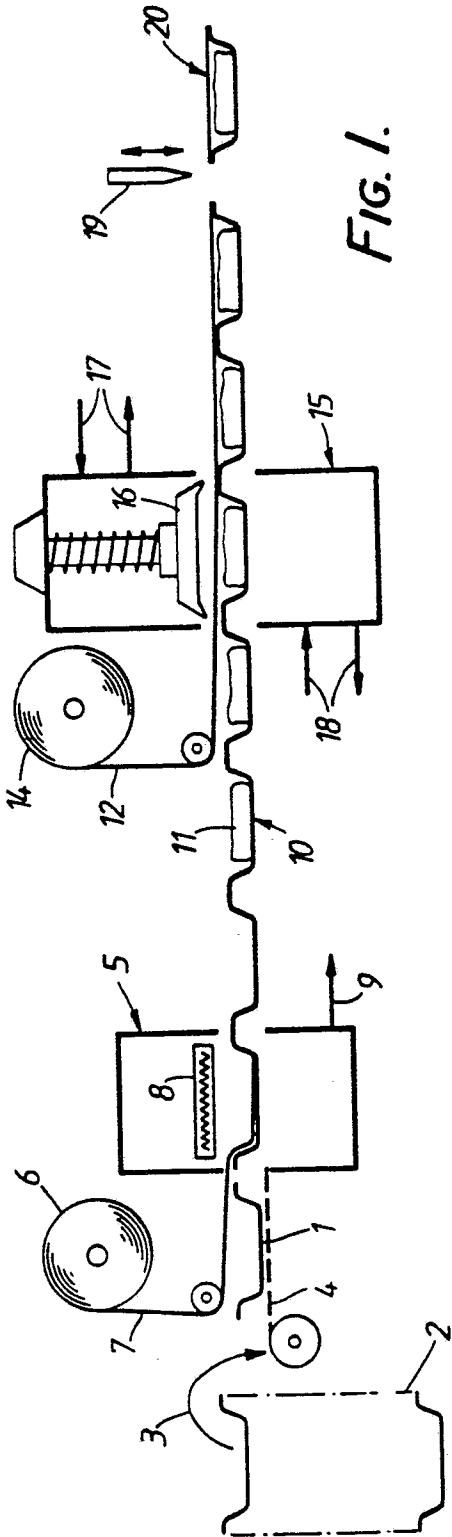

FIG. 1.

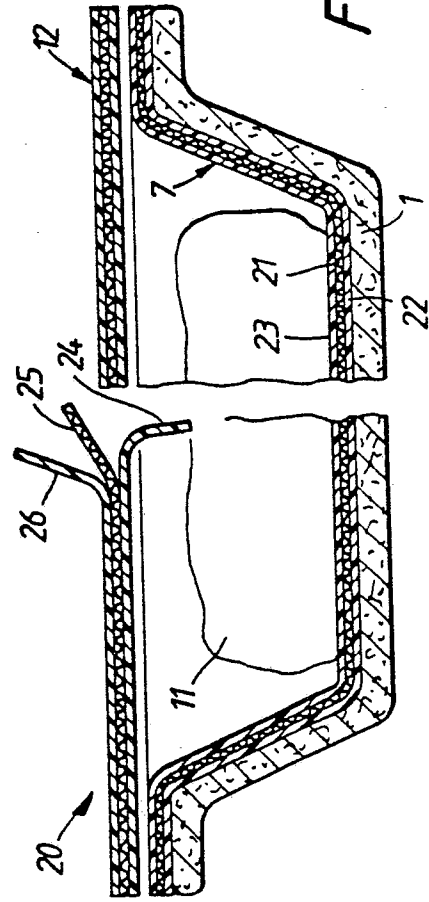

FIG. 2.