

19



Europäisches Patentamt
 European Patent Office
 Office européen des brevets

11 Publication number:

**0 219 001
 A1**

12

EUROPEAN PATENT APPLICATION

21 Application number: 86113570.5

51 Int. Cl.4: **B43K 21/20**

22 Date of filing: 02.10.86

30 Priority: 02.10.85 JP 218034/85
 08.10.85 JP 222835/85
 05.11.85 JP 246377/85

43 Date of publication of application:
 22.04.87 Bulletin 87/17

84 Designated Contracting States:
 DE FR GB

71 Applicant: Ancos Co., Ltd.
 No. 1-19, Nishitemma 5-chome Kita-ku
 Osaka-shi Osaka(JP)

72 Inventor: Hashimoto, Yasuyuki
 14-41, Kannocho
 Nishinomiya-shi Hyogo(JP)
 Inventor: Yamashita, Haruo
 894, Fujie
 Akashi-shi Hyogo(JP)

74 Representative: Eitle, Werner, Dipl.-Ing. et al
 Hoffmann, Eitle & Partner Patentanwälte
 Arabellastrasse 4
 D-8000 München 81(DE)

54 **Mechanical pencil.**

57 A mechanical pencil comprises a hollow elongated body having at least one axial slit (1a) at its normal gripping portion which is naturally gripped by writer's fingers, a chuck (7) for chucking and releasing a lead, the chuck having a plurality of heads - (7a) and a rear portion, a chuck tightening member - (8) disposed on a rear side of the heads (7a) of the chuck for closing the plurality of heads (7a), at least one pinching member (2) disposed along the axial slit (1a), the pinching member (2) being secured to the body and a lead holding member (5) for normally holding the lead, the lead holding member (5) being disposed on a front side of the heads (7a) of the chuck (7). The lead is caused to extend from a frontmost end of the body by the cooperation among the pinching member (2), the chuck (7), the lead holding member (5), the chuck tightening member - (8), without changing a writer's writing finger position.

EP 0 219 001 A1

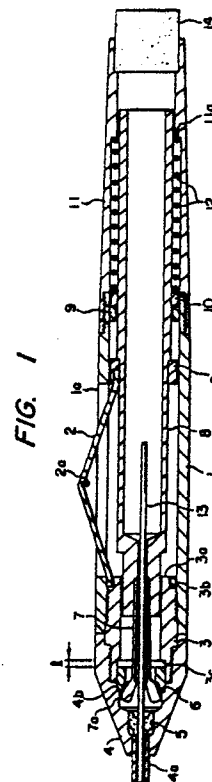

MECHANICAL PENCIL

BACKGROUND OF THE INVENTION

This invention relates to a mechanical pencil simple in construction and low in manufacturing cost in which the lead is not clamped when the pencil is not in use, but is clamped by the natural force which is provided when the holder is pinched during writing, and the lead extends by decreasing the holder pinching force and pinching the holder again when worn during writing.

A variety of lead extending mechanisms have been developed for conventional mechanical pencils in order to protrude the worn lead from the tip end of the mechanical pencil body during writing. That is, a rotary extension system, a rear end push system, a side push system, a holder bending system, a system of shaking the mechanical pencil body up and down, a system in which a ring provided at the end is pulled and released and a system in which the end portion is held and released to extend the lead.

A rear push system, the most popularizing system at the present time, has a intricacy in function that when a lead is worn out during writing, it is necessary to release a user's hold, to push a rear end of the mechanical pencil body, and to hold it again, so as to protrude the lead. In view of this drawback, mechanical pencils having the side push system, the holder bending system, or the system of shaking the body up and down have been developed. However, each of these systems still suffers from the following drawback. In the side push system, under such a condition that a pushing member be pressed by a finger, a writing operation cannot be attained since the lead is not clamped. In the holder bending system, it is difficult to protrude the lead, because the lead protruding operation would require an unnatural force and would be intricate as in the side push system. In the system of shaking the body up and down, a writer's hand must be separated sufficiently apart from a sheet, during shaking.

Further, another lead extending mechanism, a so-called automatic lead extending mechanism has been developed as shown in Japanese Patent Application Laid-Open No. 201696/1983. However, this system requires balls disposed between a chuck and a tightening part which constitute an intricate and expensive lead clamping mechanism, allowing the lead to move forwardly but not backwardly. In this system, when the lead is worn out, the lead has to extend with a slider being urged forwardly of the pencil body by a distance through which the lead is worn out. Therefore, a stable

writing operation would not be ensured because the writing force against the forwarding force of the slider must be required. Furthermore, it is necessary to push a rear end portion of the mechanical pencil to extend and retract the lead, thus, being much intricate.

In order to eliminate such problems, a mechanical pencil having the system in which a ring provided at the end of the body instead of the slider is pulled and released has been developed - (cf. Japanese Utility Model Application Laid-Open No. 67281/1984), and the system in which the end portion is held and released to extend the lead (cf. Japanese Utility Model Applications Laid-Open Nos. 60285/1985 and 60286/1985). However, each of these system still has an intricate and expensive lead clamping mechanism as described above.

On the other hand, the rotary extension systems are classified into an old system in which a lead is inserted into the chuck from the tip end of the mechanical pencil body, and a relatively new system in which the chuck from the end, and a relatively new system in which the chuck moves forwardly by rotation. The former system is scarcely employed because the operation is intricate and troublesome. In the latter system, similarly as in the rear end push system, the side push system, the holder bending system and the system of shaking the body up and down, the chuck, the tightening member and the chuck spring are provided at the inside of the front end portion of the body, and the chuck is engaged with and disengaged from the tightening member to clamp and release the lead, thereby to extend the lead. These systems are common to one another in the lead clamping mechanism and in the lead extending mechanism. That is, the chuck or a lead case coupled to the chuck moves forwardly by rotation, pushing the rear end, pushing the side, bending the holder or shaking the body up and down so that the lead kept always clamped by the chuck engaged with the tightening member extends a predetermined length and is then released.

SUMMARY OF THE INVENTION

An object of this invention is to eliminate the above-described difficulties accompanying conventional mechanical pencils.

A mechanical pencil of the invention includes: a hollow elongated body having at least one axial slit at its normal gripping portion which is naturally gripped by writer's fingers; a chuck for chucking a lead when the chuck moves backwardly and re-

leasing the lead when the chuck moves forwardly, the chuck has a plurality of heads and a rear portion, the chuck is subjected to a self-opening force urging the plurality of the heads to open outwardly, and the chuck is always urged forwardly; a chuck tightening member for closing the heads of the chuck, the chuck tightening member is disposed on a rear side of the heads of the chuck; at least one pinching member disposed along the axial slit, the pinching member is secured at least at its first end to the body in such a manner, that the member does not come off the body; a lead holding member for normally holding the lead with a predetermined holding force, and the lead holding member is disposed on a front side of the heads of the chuck. A radial shift of the pinching member is translated into a linear axial movement between the chuck tightening member and the chuck. The chuck moves at a predetermined light distance relative to the lead while the lead is clamped by the chuck, and the lead is caused to extend from a frontmost end of the body by the cooperation among the pinching member, the chuck, the lead holding member, the chuck tightening member, without changing a writer's writing finger position.

The present invention provides a mechanical pencil to eliminate the conventional problem that, in order to extend the lead out of the mechanical pencil, the rear end is pushed, the holder is bent, the body is shaken up and down.

Another object of the invention is to eliminate the drawbacks as follows;

The conventional mechanical pencil has the automatic lead extending mechanism which requires the balls for a lead clamping mechanism which permits the forward movement of the lead but not the backward movement, thus making the mechanism would be intricate. Further, the lead extends with the slider urged forwardly by the slider moving backwardly for writing while the lead does not extend from the tip end of a lead pipe. Therefore, the stable writing operation can not be obtained. In the conventional mechanical pencil having the ring for extending the lead operated by a finger, which is developed to eliminate the above-described shortcomings, the stable writing operation can be obtained since the lead is always projected from a tip end of a lead pipe during writing, and the lead can extend without pushing a rear end of the mechanical pencil. However, such a mechanism has such a drawback that the cost is high because it requires an intricate and expensive lead clamping mechanism. Further, the ring has to be pulled several times by the finger for extending the lead every time a predetermined short distance of the lead is worn out. Furthermore, it is necessary to push the rear end of the mechanical pencil in

order to retract the lead excessively extending from the tip end of the lead pipe.

According to the present invention, the following effects or merits are provided:

The lead can extend from the tip end of the mechanical pencil body only by decreasing the mechanical pencil holding force and pinching the mechanical pencil again with the positions of the fingers holding the mechanical pencil maintained unchanged during writing.

A mechanical pencil of the invention having a simple mechanism does not require the lead clamping mechanism required by the conventional mechanical pencil, which permits the forward movement of the lead but not the backward movement, in order to obtain the similar function as the conventional mechanical pencil.

A novel mechanical pencil can be manufactured at low cost by utilizing components of a conventional mechanical pencil,

When the mechanical pencil is not in use, the lead is not clamped, and therefore the lead can readily be retracted into the mechanical pencil body and the difficulty that the lead may be broken down when the mechanical pencil is dropped can be prevented.

The length of the lead which cannot be used any longer (so-called "a waste lead") can be minimized, A troublesome slider is not required.

A stable writing operation can be obtained since the lead can extend at a required length during writing. In order to solve the above-described problems. The invention has been developed on the concept that a writing implement is used by holding it between the fingers and it is pinched according to a writing pressure required. That is, in the invention, the technologies (US-A-4 358 210 and US-A-4 270 870), which has been continually developed by the present applicant has been considered to provide a mechanical pencil in which when it is held between the fingers the chuck is moved backwardly to extend the lead out of the mechanical pencil body with a simple mechanism, in contrast to the conventional push type mechanical pencil in which the chuck moves forwardly to extend the lead out of the mechanical pencil with an intricate and expensive mechanism.

In the mechanical pencil according to the invention, a chuck with two or three, for example, chuck heads having an opening force is provided in the front end portion of the mechanical pencil body in such a manner that the chuck is urged forwardly, a tightening member which is engaged with and disengaged from the chuck heads to clamp and release the lead is disposed at the rear side of the chuck heads in such a manner that the tightening part is slidable in a predetermined short distance, a lead holding part for always holding the lead with a

predetermined force is provided in the front end portion of the body in such a manner that the lead holding part is located in front of the chuck, one or a plurality of a pinching members are provided at the portion of the outer cylindrical wall of the body which is held between the fingers during writing in such a manner that the pinching members do not come off the body, and parts of the pinching members are engaged with the chuck, so that the chuck moves backwardly when the pinching members are depressed by the fingers.

In the mechanical pencil of the invention, thus constructed as described above, when the pinching members are not depressed by the fingers, the chuck, being urged forwardly, is located in front of the forward position of the tightening member with the chuck heads opened. The tightening member is dropped to the forward position by its own weight, and the front end of the tightening member is substantially in contact with the chuck heads; however, it is backwardly movable a predetermined short distance. When, under this condition, the lead is inserted into the chuck from behind and the tip end of the mechanical pencil is set down, the lead passes through the opened chuck heads and abuts against the lead holding part provided in the front end portion of the mechanical pencil body.

When, under this condition, the pinching members are depressed by the fingers, the chuck moves backwardly because parts of the pinching members are engaged with the chuck. More specifically, first the chuck together with the tightening member moves backwardly the distance for which the tightening member can move backwardly, while the chuck heads maintained open. When the chuck further moves backwardly, the tightening member, being unable to move backwardly any farther, is engaged with the heads of the chuck to cause the chuck heads to clamp the lead. The lead is detained by its own weight while the chuck together with the tightening member moves backwardly the predetermined short distance with the chuck heads maintained open. Therefore, when the force of depressing the pinching members is decreased, the chuck heads urged forwardly is engaged with the tightening member and moves forwardly the predetermined short distance while clamping the lead, as a result of which the lead is inserted as much as the length corresponding to the distance into the lead holding part provided in the front end portion of the body. When the pinching member depressing force is further decreased, the chuck is disengaged from the tightening member whose forward movement is prevented, so that the chuck heads are opened to release the lead, i.e., the mechanical pencil is placed in the initial state in which the pinching members are to be depressed.

When the pinching members are depressed and released again, the lead moves as much as the length corresponding to the slide distance of the tightening member into the lead holding part. The lead extends from the tip end of the mechanical pencil by repeating the pinching member depressing and releasing operation in a few times. Under this condition, the mechanical pencil is pinched to write. That is, when the pinching members are held by the fingers, the chuck is engaged with the tightening member to clamp the lead, and therefore the lead will never retract into the mechanical pencil by the writing pressure. In the case where the lead extending out of the mechanical pencil is worn out, the lead can extend out of the mechanical pencil again so as to continue the writing operation by decreasing the pinching member depressing force and depressing the pinching members again with the position of the fingers holding the mechanical pencil maintained unchanged.

As is apparent from the above description, when the pinching members are held by the fingers, the chuck together with the tightening member moves backwardly by the distance for which the tightening member is slidable, with the chuck head maintained open, so that the lead extends forwardly as much as the length corresponding to the distance. When the pinching members are released, the lead thus extends moves forwardly as much as the tightening member's slidable distance while being clamped by the chuck engaged with the tightening member, despite of a holding force of the lead holding part.

According to another aspect of the invention, there is provided a mechanical pencil comprising a hollow elongated body having at least one axial slit at its normal gripping portion which is naturally gripped by writer's fingers; a chuck for chucking and releasing a lead, the chuck has a plurality of heads and a rear portion, the chuck is subjected to a self-opening force urging the plurality of heads to open outwardly; a chuck tightening member for closing the heads of the chuck, the chuck tightening member is disposed on a rear side of the heads of the chuck; at least one pinching member disposed along the axial slit, the pinching member is secured at least at its first end to the body in such a manner, that the pinching member does not come off the body; and a slider which is disposed on a front side of the chuck, the slider is axially movable at a predetermined distance. The slider has a lead holding member disposed on the front side of the chuck, the lead holding member holds the lead with a predetermined holding force. A radial shift of the pinching member is translated into a linear axial movement between the chuck tightening member and the chuck. The chuck

moves at a predetermined distance relative to a position where the lead is clamped by the chuck, and the lead is caused to extend from a frontmost end of the body by the cooperation among the pinching member, the chuck, the lead holding member, the chuck tightening member and the slider, without changing a writer's writing finger position.

The chuck with, for example, two or three chuck heads having an opening force is provided in the front end portion of the mechanical pencil body. The tightening member engaged with and disengaged from the chuck heads to clamp and release the lead is disposed at the rear side of the chuck heads. The tightening part receiving member in which the tightening member is slidable in a predetermined short distance. The sliding member having the lead holding member provided at the front side of the chuck for always holding the lead with a predetermined force, the sliding member being engaged with the tightening part receiving member. The sliding member is always urged rearwardly by an elastic force of an elastic member, one or plural pinching members are provided in such a manner that the rear end portion thereof is connected to the mechanical pencil body so that the front end portion allows the sliding member to move forwardly and to relatively move the chuck rearwardly against the elastic force of the elastic member when the pinching members are depressed in a radial direction of the mechanical pencil body.

In the mechanism described above, when the pinching members are not depressed by the fingers, a slider is urged backwardly together with a tightening member receiving member by an elastic force of an elastic member. Thus, a tightening member disposed in the tightening member receiving member is not engaged with chuck heads so that the chuck heads are opened. When, under this condition, the lead is inserted into the chuck from an open rear end and the tip end of the mechanical pencil is set down, the lead passes through the opened chuck heads by its own weight and comes into abutment with a rear end of a lead holding part provided in the middle portion of the mechanical pencil body.

When, under this condition, the pinching members are depressed toward the radial direction of the mechanical pencil by the fingers, the sliding member is forced to move forwardly against the elastic force of the elastic member, by the ends of the pinching members. The tightening member abuts against the rear ends of the opened chuck heads by its own weight. Since there is the predetermined short distance between the rear end of the tightening member and the tightening member receiving member, the slider, a lead holding mem-

ber and the tightening part receiving member move forwardly by the predetermined short distance. The lead also moves forwardly with its own weight into the chuck opened.

When the pinching members are further depressed by the fingers, the tightening member is urged to move forwardly together with the sliding member, the lead holding part and the tightening member receiving member so that the tightening member is engaged with the opened chuck heads to clamp the lead.

Next, when the force of depressing the pinching members is slightly decreased, the sliding member moves backwardly by the elastic force of the elastic member, together with the lead holding member and the tightening member receiving member. However, the tightening member does not move in the predetermined short distance, that is, until the end of the tightening member abuts against the sliding member, being kept engaged with the chuck to clamp the lead. Therefore, the tip end of the lead is inserted into the lead holding member moving backwardly by the predetermined short distance as much as the length corresponding to the distance. When the force of depressing the pinching members is further decreased, the sliding member further moves backwardly so that the tightening member also moves backwardly together with the sliding member, then disengaged from the chuck heads to thereby release the lead.

In this manner, when the pinching members are depressed and released again, the lead moves by the length corresponding to the sliding distance of the tightening member in the tightening member receiving member, while the lead is clamped by the chuck engaged with tightening member. The lead extends from the tip end of the mechanical pencil body by repeating the pinching member depressing and releasing operation. Under this condition, the mechanical pencil is pinched to write.

When the lead which extends from the tip end of the mechanical pencil body is worn out, the lead can readily extend out of the mechanical pencil again so as to continue the writing operation by only decreasing the pinching member depressing force once and depressing the pinching member again.

BRIEF DESCRIPTION OF THE DRAWINGS

Fig. 1 is a longitudinal sectional view showing a first embodiment of the invention.

Figs. 2 to 5 are sectional diagrams for a description of the operations of the mechanical pencil shown in Fig. 1.

Fig. 6 is a longitudinal sectional view of a mechanical pencil which is a second embodiment of the invention.

Fig. 7 is a longitudinal sectional view showing essential components of a mechanical pencil which is a third embodiment of the invention.

Fig. 8 is a perspective view showing some of the components shown in Fig. 7.

Figs. 9 and 10 are longitudinal sectional views of mechanical pencils which are fourth and fifth embodiments of the invention, respectively.

Figs. 11 to 20 are longitudinal sectional views showing some improvements or their essential components of the first embodiment of the invention.

Fig. 21 is a longitudinal sectional view showing a sixth embodiment of the invention.

Figs. 22 to 25 are sectional diagrams for a description of the operations of the mechanical pencil shown in Fig. 21.

Fig. 26 is a longitudinal sectional view showing a seventh embodiment of the invention.

Fig. 27 shows a eighth embodiment of the invention.

Figs. 28 through 32 are sectional diagrams for a description of the operations of the mechanical pencil shown in Fig. 26.

Fig. 33 is a longitudinal sectional view showing a ninth embodiment of the invention.

Figs. 34 and 35 are longitudinal sectional views showing a tenth and an eleventh embodiments of the invention, respectively.

Fig. 36 is a longitudinal sectional view showing a twelfth embodiment of the invention.

Figs. 37 through 40 are sectional diagrams for a description of the operations of the mechanical pencil shown in Fig. 36.

Fig. 41 is a longitudinal sectional view showing essential components of a mechanical pencil which is a thirteenth embodiment of the invention.

DETAILED DESCRIPTION OF THE INVENTION

The invention will now be described with reference to the accompanying drawings.

Fig. 1 is a longitudinal sectional view of a mechanical pencil according to a first embodiment of the invention. More specifically, Fig. 1 shows a state in which the mechanical pencil is not in use with its pinching members being released from the writer's fingers.

In Fig. 1, reference numeral 1 generally designates a front holder or barrel. One or plural slits - (three slits in Fig. 1) 1a are formed in the portion of the cylindrical wall of the front holder 1 which is pinched between the fingers during writing. Threads are formed in the front end portion of the

front holder 1, and associated threads are formed in the rear end portion thereof. The mechanical pencil has pinching members 2 the number of which is equal to that of the slits 1a (three pinching members 2 in Fig. 1). Each of the pinching members 2 has a hinge part 2a. The front ends of the pinching members 2 form a ring-shaped part. The pinching members 2 are assembled with the front holder as follows: First, the rear end portions of the pinching members 2 are inserted into the front holder through its front open end in such a manner that they are aligned with the slits 1a, respectively - (a coupling 3 being not attached to the front holder yet). Thereafter, the pinching members 2 are pulled out of the slits 1a until the ring-shaped part comes to the front ends of the slits 1a. Under this condition, the threads of the rear end portion of the coupling 3 are engaged with the threads of the front end portion of the front holder 1, and the coupling 3 is fixedly secured to the front holder 1 when the small diameter portion 3a formed at the rear end portion of the coupling 3 is inserted into the ring-shaped part of the pinching members 2 and the front end face of the ring-shaped part abuts against the step 3b of the coupling 3.

Next, a lead pipe 4a is press-fitted into the front end portion of a metal end piece 4, and a lead holding member 5 is also press-fitted into the recess formed in the front end portion of the metal end piece 4. The lead holding member 5 is used to hold the lead with a certain force. The metal end piece 4 has a step 4b to prevent the forward movement of a tightening member 6; however, the opened heads 7a of a chuck 7 can go forwardly of the step 4b (towards the left-handed side of Fig. 1). After the tightening member 6 is inserted into the large inside diameter part formed at the front end portion of the coupling 3, the threads formed in the front end portion of the coupling 3 are engaged with the threads formed in the rear end portion of the metal end piece 4 so that the metal end piece 4 is coupled through the coupling 3 to the front holder 1. In this case, the tightening member 6 is movable between the step 3c of the coupling 3 and the step 4b of the metal end piece 4.

Under this condition, the rear end portion of the chuck 7 is press-fitted into a small diameter front end portion of a lead case 8. The front end portion of the chuck 7 is split into two or three parts (three parts in Fig. 1) which have the aforementioned heads 7a arranged in a large diameter circuit. The heads 7a tend to open; however, they hold the lead when engaged with the tightening member 6. In the case when no lead is provided in the chuck 7, the heads 7a of the chuck 7 can be set closer to one another so that the heads 7a are inserted into the tightening member 6 from behind. A ring 8a has bottomed holes in the front end face the number

thereof is equal to the number of pinching members 2. The ring 8a is fixedly mounted on the cylindrical outer wall of the lead case 8 in such a manner that the front end face is in alignment with the rear ends of the slits 1a of the front holder 1. In assembling the mechanical holder, the ring 8a is fixedly mounted on the lead case 8, the assembly of the lead case 8 and the chuck 7 is inserted into the front holder 1 from behind, and the heads 7a of the chuck 7 pass through the tightening member 6 and open then.

A stop 9 is fixedly secured to the inner wall of the front holder 1 at the rear of the ring 8a mounted on the lead case 8. A locking ring 10 is fixedly mounted on the outer wall of the lead case 8 in such a manner that it abuts against the stop 9. The forward movement of the lead case 8 is prevented by the abutment of the stop 9 with the locking ring 10, and in this case the heads 7a of the chuck 7 are held open in front of the tightening member 6. Under this condition, the bottomed holes in the ring 8a are aligned with the pinching members 2 by turning the lead case 8, and the rear end portions of the pinching members 2 are inserted into the bottomed holes.

Next, a spring 12 is inserted into a rear holder 11 with rear end thereof abutting against the step 11a formed in the rear holder 11, and the threads cut in the front end portion of the rear holder 11 are engaged with the threads formed in the rear end portion of the front holder 1. Thus, a mechanical pencil body has been formed by the front holder 1, the metal end piece 4 and the rear holder 11. In the last assembling step, a lead 13 and spare leads are inserted into the lead case 8 through the rear end opening of the rear holder 11, and an eraser 14 is fitted in the rear end of the rear holder 11.

It is not always necessary to provide the stop 9 in the front holder 1. In the case where the stop 9 is eliminated, the lead case 8 and the chuck 7 move forwardly until the front end of the chuck 7 abuts against the step formed in the metal end piece 4 or the rear end of the lead holding member 5. This will cause no trouble with the mechanical pencil. Since the front end of the chuck 7 is located much closer to the tip end of the mechanical pencil, the length of the lead which cannot be used any longer (so-called "waste lead") can be minimized.

In the case of Fig. 1, the front end of the lead 13 is flush with the end of the lead pipe 4a, and the lead 13 is held by the lead holding member 5 but it is not clamped by the chuck 7. Since the pinching members 2 are not pinched by the fingers, the lead case 8 does not retract (moved backwardly); that is, the lead case 8 moves forwardly by the elastic force of the spring 12 until the locking ring 10

comes into abutment with the stop 9. The tightening member 6 moves forwardly by its own weight until the front end of the tightening member 6 abuts against the step 4b of the metal end piece 4 and the tightening member 6 is substantially in contact with the opened chuck heads 7a of the chuck 7.

The operation of the mechanical pencil held as shown in Fig. 1 will be described with reference to Figs. 2 through 5.

Fig. 2 shows the mechanical pencil whose pinching members 2 are slightly pressed with the fingers. That is, the rear ends (or movable ends) of the pinching members 2 move backwardly, so that the spring 12 is slightly contracted, and the lead case 8 and the chuck 7 move backwardly through the ring 8a. The chuck heads 7a of the chuck 7 move backwardly together with the tightening member 6 while being kept opened, and the rear end of the tightening member 6 comes into abutment with the step 3c of the coupling 3. The lead 13, being held by the lead holding member 5, is kept stopped, and therefore the lead 13 is let out of the chuck 7 by the distance l through which the chuck 7 and the tightening member 6 move backwardly without engaging with each other.

Fig. 3 shows the mechanical pencil in which the pinching members 2 are further pressed by the fingers to clamp the lead 13. The movable ends of the pinching members 2 further move backwardly, so that the lead case 8 moves backwardly while the spring 12 is contracted. In this operation, the tightening member 6 is kept stopped as shown in Fig. 2, the chuck heads 7a are caused to enter into the tightening member 6 to clamp the lead 13.

Fig. 4 shows the mechanical pencil in which the pressure applied to the pinching members 2 is slightly decreased under the condition that the mechanical pencil is held as shown in Fig. 3. The lead case 8 moves forwardly through the locking ring 10 by the elastic force of the spring 12, and the chuck 7 coupled to the lead case 8 also moves forwardly, the chuck heads 7a of the chuck 7 move forwardly while holding the lead 13 through engagement with the tightening member 6 until the front end of the tightening member 6 comes into abutment with the step 4b of the metal end piece 4; that is, the chuck heads 7a move forwardly by the distance l . Accordingly, the lead 13 moves forwardly against the holding force of the lead holding member 5 while being clamped, so that it is fed out of the lead pipe 4a as long as the distance l .

Fig. 5 shows the mechanical pencil in which the pressure exerted on the pinching members 2 is further decreased when the mechanical pencil is held as shown in Fig. 4. The lead case 8 and the chuck 7 further move forwardly through the locking ring 10 by the elastic force of the spring 12. On the

other hand, since the tightening part 6 cannot move forwardly any longer, only the chuck 7 moves forwardly. As a result, the chuck heads 7a open while being disengaged from the tightening member 6. In this operation, the tightening member 6 is flicked back to the step 3c of the coupling 3 by the opening force of the chuck heads 7a once; however it is returned immediately as shown in Fig. 5 by its gravitational force.

The state of the mechanical pencil shown in Fig. 5 is different from that of the mechanical pencil shown in Fig. 1 only in that the lead is fed out of the lead pipe 4a in the metal end piece 4 as long as the distance l for which the lead has moved forwardly during the operation from Fig. 1 to Fig. 2.

When the mechanical pencil is held as shown in Fig. 5, the lead 13 is not clamped. Therefore, it is necessary to apply pressure to the pinching members 2 when writing; that is, it is necessary to clamp the lead as shown in Fig. 3. In Fig. 3, the lead is clamped by the chuck heads 7a of the chuck 7 and the tightening member 6 which are engaged with each other, and therefore it will not be pushed back into the holder even when the writing pressure is applied thereto. On the other hand, when the mechanical pencil held as shown in Fig. 5 is not used for writing, the lead should be pushed back into the lead pipe 4a by pushing it against the finger tip or the sheet. Since the lead 13 is not clamped, it is readily pushed back while sliding along the lead holding member 5.

Fig. 6 is a longitudinal sectional view of a mechanical pencil which is a second embodiment of the invention.

In the second embodiment, pinching members 2 are composed of elongated leaf springs which are curved outwardly. The front end portions of the pinching members 2 are inserted into bottomed holes which are formed in the large diameter front end portion 1b of a front holder 1. The rear end portions of the pinching members 2 are connected to a ring-shaped part, which is inserted in a ring 15. The ring 15 is connected through two or three legs (three legs in Fig. 6) to a doughnut-shaped part at the position where the legs are substantially in contact with the outer cylindrical wall of the lead case 8. The legs of the ring 15 extend through slits 11b formed in the front end portion of a rear holder 11. No slit is formed in the front holder 1. In this second embodiment, the front holder 1 is threadedly engaged with the metal end piece 4, to thereby dispense with the coupling 3 in the first embodiment.

The mechanical pencil of the second embodiment is assembled as follows:

The tightening member 6 is inserted into the metal end piece 4, and the metal end piece 4 is

threadedly engaged with the front holder 1. Next, the legs of the ring 15 are inserted into the slits 11b of the rear holder 11, and the stop 9 is fixedly fitted in the rear holder 11. Under this condition, the ring-shaped part formed at the rear ends (or movable ends) of the pinching members 2 is inserted into the ring 15, and the rear holder 11 is threadedly engaged with the front holder 1. In this operation, the front end portions of the pinching members 2 are aligned with the bottomed holes formed in the front holder 1 and fixedly fitted into the bottomed holes. The assembly of the chuck 7 and the lead case 8 is inserted into the mechanical pencil body through the rear end opening of the rear holder 11 in such a manner that, when the chuck heads 7a pass through the tightening member 6 and opened, the ring 15 is prevented from moving forwardly with abutting against the stop 9. In this connection, a collar 8b is previously provided at the position in the lead case 8 where the ring 15 abuts against the stop 9. A spring 12 is inserted into the rear holder 11 through its rear end opening. Furthermore, a cylinder 16 is inserted into the rear holder 11 through its rear end opening, and is fixed in the rear holder 11 with the spring 12 compressed to some extent. Thereafter, a lead 13 or spare leads are inserted into the lead case 8, and an eraser 14 is fitted in the rear end opening of the rear holder 17. A drum-shaped thin rubber cylinder 17 is put on the pinching members 2 so that the pinching members 2 can be snugly held between the fingers and cannot be seen from outside.

The operation of the second embodiment is the same as that of the first embodiment.

Fig. 7 is a longitudinal sectional diagram showing essential components of a mechanical pencil according to a third embodiment of the invention. Fig. 8 is a perspective view showing a part of Fig. 7. In the third embodiment, only one pinching member 2 is employed. The rear end portion of the pinching member 2 is locked, and the front end portion is movable. The pinching member 2 is not deformed when held between the fingers. However, when the pinching members 2 is held between the fingers, protrusions 2b provided at both sides of the inner surface of the front end portion of the pinching member 2 push the sloped surface 18a formed at the front end of a cylinder 18 which is inserted into the front end portion of the lead case 8, thus moving the lead case 8 backwardly against the spring 12 (not shown). As is apparent from the above description, the pinching member 2 is designed so that the front end moves towards the central axis of the mechanical pencil with the rear end as the fulcrum; however, when the pinching member 2 is pinched by the finger or released, the

third embodiment operates in the same manner as the first or second embodiment.

Fig. 9 is a longitudinal sectional view showing a mechanical pencil which is a fourth embodiment of the invention. In the fourth embodiment, when the pinching members 2 are fully pressed, the chuck heads 7a of the chuck 7 are engaged with the tightening member 6 to clamp the lead 13, and, after it has become difficult for the tightening member 6, the chuck 7 and the lead case 8 to move backwardly, a ring 19 in which the rear end portions of the pinching members 2 are inserted contracts a strong spring 20 to further move them backwardly. In such a fourth embodiment, the ring 19 can move backwardly along the lead case 8 and is supported by the strong spring 20 interposed between a spring retaining ring 21 and the ring 19. Therefore, the strong spring 20 will not be contracted before the weak spring 12.

Fig. 10 is a longitudinal sectional view showing a mechanical pencil which is a fifth embodiment of the invention.

In the fifth embodiment, the coupling 3 is made larger in inside diameter so as to accommodate a strong spring 22 and a tightening-member receiving member 23, and the tightening member 6 is movable between the step 23a of the tightening member receiving member 23 and the step 4b of the metal end piece 4. In the fifth embodiment also, the strong spring 22 will not be contracted before the weak spring 12 has been retracted. After the tightening member 6 has abutted against the tightening-member receiving member 23 by fully pressing the pinching members, the spring 23 is contracted to slightly move backwardly the tightening member 6, the chuck 7 and the lead case 8.

Each of the fourth and fifth embodiments is so designed as to prevent the difficulty that, when the pinching members are fully pressed by the fingers, the chuck heads are strongly fitted into the tightening member to break the lead. Furthermore, in the fourth and fifth embodiments, the pinching members can be fully pressed in snug touch.

Figs. 11 to 14 show an improvement of the foregoing embodiments. In Figs. 11 to 14, a thin coupling pipe 501 is interposed between a chuck 407 and a lead case 408, and a cone 502 is mounted on the coupling pipe 501 in such a manner that the cone 502 is coaxial with the coupling pipe 501. Rollers 503 are coupled to pinching members 402, respectively. More specifically, the rollers 503 are rotatably mounted on the pinching members 402 through bearings 504, respectively, in such a manner that the rollers 503 are in contact with a conical surface 505 of the cone 502.

In this embodiment, the pinching members 402 may be uniformly retracted radially inwardly. Each of the pinching members 402 is retracted to close

slits 401a formed in the front holder 401; that is, the outer surfaces of the pinching members 402 are flush with the outer cylindrical surface of the front holder 401 as shown in Fig. 12.

In the embodiment, the rollers 503 roll on the conical surface 505 of the cone 502. When the pinching members 402 are depressed radially inwardly to move the cone 502 in the axial direction, a friction between the rollers 503 and the cone 502 is kept substantially at zero. The cone 502 is moved relative to the rollers 503 with ease by depressing or releasing the pinching members 402. Thus, the chuck 407 can move quickly together with the cone 502 in response to the actuation of the pinching members 402.

In the above-described embodiment, the coupling pipe 501 on which the cone 502 is mounted has a small diameter. The cone 502 shown in Fig. 13 is effectively moved an axial distance L2 when the pinching members 402 are depressed a radial distance L1. Thus, the outer diameter of the barrel of the pencil may be decreased.

Fig. 15 shows one modification of the mechanical pencil shown in Fig. 11. In the modification, each of rollers 503a has the surface which is curved inwardly so that the roller is held in contact with the conical surface of the cone 502.

Fig. 16 shows another modification of the mechanical pencil shown in Fig. 11. In the modification, each of the pinching members 402 is provided with a ball 506 instead of the roller 503. The ball 506 is interposed between the pinching member 402 and the cone 502. The ball 506 is rotatably fitted in a hole 507 formed in the front holder 401 in such a manner that a half or less part of the ball is protruded out of the front holder.

Fig. 17 shows a third modification of the mechanical pencil shown in Fig. 11. In the modification, a ball 509 is rotatably fitted in a ball receiving part 508 which extends from each of the pinching members 402, and guide recesses 510 for guiding the balls 509 are formed in the conical surface of the cone 502.

Fig. 18 shows a fourth modification of the mechanical pencil shown in Fig. 11. In the modification, a ball receiving part 511 extending from each of the pinching members 402 embraces a ball 512.

Figs. 19 and 20 show a fifth modification of the mechanical pencil shown in Fig. 11. In the modification, a sloped part 513 extending from each of the pinching members 402 is engaged with a roller 503b which is mounted on a bearing 514 provided on the coupling pipe 501 as shown in Fig. 20.

In the mechanical pencils shown in Figs. 11 through 20, instead of the cones 502 and 513, a pyramid-shaped members such as for instance a triangular pyramid may be employed. Furthermore, these mechanical pencils are not limited to a cone,

or a solid member having slant surfaces. That is, the cone may be replaced by a solid body having a curved surface such as a paraboloid.

While a few embodiments of the invention have been described, the invention is not limited thereto or thereby. That is, any mechanism in which the chuck is moved backwardly by pressing and releasing the pinching members may be employed. If the pinching members have a strong restoring force, the spring urging the lead case forwardly may be eliminated by connecting the movable ends of the pinching members to the chunk or lead case. Various components of the mechanical pencil may be combined into one unit. The materials and the configurations of these components are not limited to those which have been described above. Furthermore, the assembling procedure is also not limited to that which has been described above. In addition, various changes and modifications may be made in the above-described embodiments without departing from the invention.

As is apparent from the above description, the foregoing embodiments of the invention provides the following effects or merits:

A writing operation can be achieved with the holder naturally held between the fingers. The lead can extend without changing the positions of the fingers holding the pinching members and without separating the hand largely apart from the sheet; that is, extension of the lead can be accomplishing by releasing the pinching members, i.e., decreasing the pinching force, and pinching the pinching members again.

The lead clamping mechanism of a conventional push type mechanical pencil. Therefore, the components of the mechanical pencil of the invention can be readily obtained. Furthermore, the mechanical pencil of the invention is small in number of the components, and the components can readily be manufactured and assembled into the mechanical pencil. Thus, the mechanical pencil positive in operation can be manufactured at low cost according to the invention.

In clamping the lead by operating the pinching members, the chuck moves backwardly to engage with the tightening member. Therefore, this method provides a stable writing operation as compared with a method in which the pinching members move the tightening member forwardly so as to be engaged with the chuck.

The chuck will not move forwardly by operating the pinching member. Therefore, the chuck can be located much closer to the rear side of the lead holding part or at the position where the chuck abuts against the lead holding member, whereby the length of a lead which cannot be used any longer (so-called "a waste lead") can be minimized.

When the mechanical pencil is not in use, the lead is not clamped by the chuck heads, and the lead can readily retract into the body, and the difficulty that the lead may be broken when the mechanical pencil is dropped can be eliminated.

The lead holding member and the metal end piece can be readily manufactured and assembled into the mechanical pencil since the lead holding member can be provided at the inside of the metal end piece as is similar to the conventional mechanical pencil having the push system.

The stable writing operation can be ensured since the lead can extend from the tip end of the pipe by a predetermined length during writing.

Fig. 21 is a longitudinal sectional view of a mechanical pencil according to another embodiment of the invention. More specifically, Fig. 21 shows the mechanical pencil which is not in use with its pinching member released.

In Fig. 21, reference numeral 101 designates a front holder and 102 designates a rear holder. A mechanical pencil body is formed by engaging these two holders. A front holder front end portion 101a of the front holder is formed at the end of the front holder 101. A lead pipe 101b is press-fitted into the front holder front end portion 101a. One or plural slits (three slits in Fig. 21) 101c are formed rearwardly of the front holder front end portion 101a of the front holder 101. There are provided one or plural (three in Fig. 21) pinching members 103 in which rear ends thereof abut against a front step 102a of the rear holder 102. The rear ends of the pinching members 103 form a ring-shaped part which abuts against a step portion of a rear holder front end portion 102b of the rear holder 102. Each of the pinching members 103 has a hinge part 103a. The front ends of the pinching members 103 are inserted into bottomed holes disposed in a rear end portion 104a of the sliding member 104. The sliding member 104 is provided with a cylindrical member 104b at the center portion passing through one or plural (three in Fig. 21) legs. A lead holding member 105 made of an elastic member, such as resin, is press-fitted into the cylindrical member 104b. The legs of the sliding member 104 pass through the slits 101c of the front holder 101 the number of which is equal to that of the legs. Spring 106 is provided between the sliding member 104 and the step portion formed inside the front holder front end portion 101a of the front holder 101. The sliding member 104 is always urged rearwardly (towards the right-handed side of Fig. 21) by the elastic force of the spring 106. The rearward movement of the sliding member 104 is prevented by the stopper 107 fixedly secured to the inner wall of the front holder 101. The sliding member 104 is provided with a tightening member receiving member 108 at the rear portion and a tightening mem-

ber 109 is inserted in the tightening member receiving member 108. The rear end portion of the tightening member 109 forms a tightening portion 109a engaged with and disengaged from the heads 110a of a chuck 110, so as to clamp and release the lead. The rear portion of the tightening member receiving member 108 is provided with a stop ring 108a for preventing the rearward movement of the tightening member 109.

In the condition shown in Fig. 21, the tightening member 109 abuts, with its own weight, against the rear end of the sliding member 104, and the front end of the tightening portion 109a is substantially in contact with the opened heads 110a of the chuck 110. There is provided a predetermined short distance l between the rear end of the tightening member 109 and the stop ring 108a, thus the tightening member 109 is slidable.

The front end portion of the chuck 110 is split into two or three parts (three parts in Fig. 21) and tends to open. The rear end of the chuck 110 is connected with a lead case 111. The inner front portion of the lead case 111 is tapered to form a lead guide portion 111a. The outer rear portion of the lead case 111 is provided with a protrusion 111b. A spring 113 is disposed between the protrusion 111b and a spring stopper ring 112 fixedly secured to the inner front surface of the rear holder 102, so that the lead case 111 is always urged rearwardly (towards the right-handed side of Fig. 21) by the elastic force of the spring 113. The backward movement of the lead case 111 is prevented in such a manner that the protrusion 111b of the lead case 111 abuts against a step 102c formed at the inner rear surface of the rear holder 102. An eraser 114 is detachably fitted in the rear portion of the rear holder 102, so that the lead 115 and spare leads are inserted into the lead case 108 through the rear end opening of the rear holder 102. In the condition shown in Fig. 21, the heads of the chuck 110 opens with its own opening force, accordingly, the lead 115 is not clamped. The lead 115 is held, with a predetermined force, by the lead holding member 105 press-fitted into the center portion of the sliding member 104, and the tip end of the lead 115 is flush with the end of the lead pipe 101b. The tightening member 109 is stopped moving in the manner that the front end thereof abuts against the sliding member 104, and the tightening portion 109a is substantially in contact with the rear side of the opened heads 110a of the chuck 110. There is provided a distance l between the front end of the stop ring 108a disposed at the rear end of the tightening member receiving member 108 and the rear end of the tightening member 109.

The operation of the mechanical pencil held as shown in Fig. 21 will be described with reference to Figs. 22 through 25.

Fig. 22 shows the mechanical pencil whose pinching members 103 are slightly depressed by the fingers. In this condition, the sliding member 104 slightly moves forwardly together with the tightening member receiving member 108 and the front end of the stop ring 108a is brought into contact with the rear end of the tightening member 109. The tightening member 109 does not move yet. The sliding member 104 moves forwardly as much as the distance l while the lead 115 held by the lead holding part 105 passes forwardly through the opened chuck 110, so that the lead 115 is fed out of the lead pipe 101b by the distance l .

Fig. 23 shows the mechanical pencil in which the pinching members 103 are further depressed by the fingers to clamp the lead 115. In this condition, the tightening part receiving member 108 and the stop ring 108a move forwardly together with the sliding member 104, so that the tightening member 109 moves forwardly to be engaged with the heads 110a of the chuck 110 so as to clamp the lead 115. In this condition, the writing is possible.

Fig. 24 shows the mechanical pencil in which the pressure applied to the pinching members 103 is slightly decreased under the condition that the mechanical pencil is held as shown in Fig. 23. The sliding member 104 moves backwardly by the elastic force of the spring 106 until the rear end of the sliding member 104 comes into abutment with the front end of the tightening member 109. Under this condition, the heads 110a of the chuck 110 are engaged with the tightening portion 109a of the tightening part 109 to keep clamping the lead 115. Therefore, the lead 115 does not move backwardly while the lead holding part 105 moves backwardly against the lead 115 by the distance l . In other words, the lead 115 extends as much as the length l .

Fig. 25 shows the mechanical pencil in which the pressure exerted to the pinching members 103 is completely decreased. In this condition, the sliding member 104 further moves backwardly together with the tightening member 109 moves backwardly. As a result, the heads 110a of the chuck 110 are opened being disengaged from the tightening portion 109a of the tightening member 109. In this operation, the tightening member 109 is flicked back to the stop ring 108a by the opening force of the heads 110a of the chuck 110 once; however, it is returned immediately with its own weight until the tightening member 109 is brought into abutment with the opened heads 110a of the chuck 110, while the front end of the tightening member 109 comes into contact with the sliding member

104. In this manner, the pencil is operable in the case where there is a short distance between the front end of the tightening member 109 and the sliding member 104 or otherwise in the case where there is a short distance between the tightening portion 109a of the tightening member 109 and the opened heads 110a of the chuck 110. In this case, the distance of the forward and backward movement of the sliding member 104 is increased by depressing and releasing the pinching members 103 corresponding to the afore mentioned short distance. However, it would be necessary that the sliding member 104 urges the tightening member 109 engaged with the heads 110a of the chuck 110 in order to open the heads 110a of the chuck 110, before the rear end of the sliding member 104 comes into abutment with the stopper 107.

Under the condition shown in Fig. 25, when the pinching members 103 are depressed by the fingers, the lead 115 further extends from the tip end of the lead pipe 101b by the distance l . Further, if the lead which extends from the tip end of the lead pipe 101b is to retract, the lead can readily be retracted only by pushing the lead by a finger tip or a sheet, since the lead is not clamped by the chuck 110.

Fig. 26 is a longitudinal sectional view of a mechanical pencil which is another embodiment of the invention.

In the embodiment shown in Fig. 26, an annular tightening member 109 which is short in length is employed, and the sliding member 104 is provided with a step portion 108b at the inner front of the tightening member receiving member 108. In this condition, when the sliding member 104 moves backwardly, the tightening member 109 is disengaged from the chuck 110 by the step portion 108b provided inner side of the tightening member receiving member 108 rather than the sliding member 104 itself.

Further, the other embodiments of the invention having the above-described system will be described as follows:

Fig. 27 is a longitudinal sectional view of a mechanical pencil according to still another embodiment of the invention. More specifically, Fig. 27 shows the mechanical pencil which is not in use with its pinching member released.

In Fig. 27, reference numeral 201 designates a front holder; 202, a rear holder. These two holders are coupled to each other to form a mechanical pencil body. The front holder 201 has a front holder front end portion 1a. A lead pipe 201b is press-fitted into the front holder front end portion 201a. The provision of the lead pipe 201b is not always required; that is, the lead pipe 201b may be dispensed with by sharpening the tip end of the front holder front end portion 201a. Two or three

slits 201c (three slits in Fig. 27) extend rearwardly from the front end portion 201a of the front holder 201. One or plural pinching members 203 (three pinching members in Fig. 27) are provided with their rear ends abutting against the front step 202a of the rear holder 202. More specifically, the rear ends of the pinching members 203 are inserted into the front end portion 202b of the rear holder 202; in other words, the rear ends are connected to one another to form an annular part which is fitted into the rear holder's front end portion 202b. Each of the pinching members 203 has a hinge part 203a. The front ends of the pinching members 203 are inserted into the bottomed holes formed in the rear end portion 204a of a sliding member 204. The sliding member 204 has a cylindrical member 204b at the center thereof which is secured through two or three legs (three legs in Fig. 27) to the sliding member 204. A lead holding member 205 is provided in the cylindrical member 204b in such a manner that it is positively held in the cylindrical member 204b. The rear end face of the lead holding member 205 is tapered so that a lead can enter thereinto with each. If the cylindrical member 204b and hence the lead holding member 205 are disposed at a forward position in the front holder's front end portion 201a and a chuck and a tightening member are also provided at forward positions, then the length of a lead which cannot be used any longer (or so-called "waste lead") can be minimized. The legs of the sliding member 204 extend through the slits 201c of the front holder 201. A spring 206 is interposed between the step provided on the inner surface of the front holder's front end portion 201a and the legs of the sliding member 204 so as to urge the sliding member 204 backwardly (to the right-handed side of Fig. 27). If the pinching members 203 have a sufficiently high restoring force, the spring may be eliminated by fixing the front ends of the pinching members 203. The movement of the sliding inner surface of the front holder 201 so that it may not move over a predetermined distance. The stop 207 may be eliminated by employing the following methods. In one of the methods, the slits 201c of the front holder 201 are closed in the portions which extends backwardly from the stop 207 in Fig. 27. In another method, the front holder's front end portion 201a is provided separately from the body, and the slits 201c from forwardly of the stopper 207 of the body (towards the left-handed side of Fig. 21), so that the body is combined with the front end portion 201a (in this case, the front holder 201 and the rear holder 202 may be integral with each other in the body). Alternatively, the stop 207 may be completely eliminated. In this case, the sliding member 204 is prevented from moving backwardly when it abuts against the front end face of the chuck;

however, there is no difficulty owing to the elastic force of the spring 206, and the materials and configurations of the sliding member 204 and the chuck.

The mechanical pencil has a cylinder-shaped tightening member 208 as shown in Fig. 27. The tightening part 208 has a tightening portion 208a at the rear end. As the tightening portion 208a is engaged with or disengaged from chuck heads 211a, the lead is held or released. A plurality of slits 208b (which is equal in number to the legs of the sliding member 204) are formed in the front portion of the tightening member 208. The legs of the sliding member 204 are inserted into the slits 208b, and then a ring 209 is fixedly secured to the front end of the tightening member 208. It is not always necessary to use the ring 209; that is, the front end portion of the tightening member 208 may be bent outwardly or inwardly so as to be engaged with the legs of the sliding member 204. A stop 210 is mounted on the outer circumferential wall of the tightening member 208. However, it is not always necessary to use the stop 210. That is, the relative movement of the sliding member 204 and the tightening member 208 is defined by the distance of movement of the legs of the sliding member 204 between the rear ends (on the right-handed side of Fig. 27) of the slits 208b of the tightening member 208 and the ring 209, and therefore it is useless to provide the stop 210 at the position corresponding to the rear ends of the slits 208b as shown in Fig. 27. However, if the slits 208b of the tightening member 208 are elongated and female threads and male threads are formed in the inner circumferential wall of the stop 210 and the outer circumferential wall of the tightening member 208 so that the stop 210 can be held at a desired position, then the supply length of a lead can be controlled. The same effect can be obtained by employing a similar method in which the slits 208b of the tightening member 208 are elongated, male threads are formed in the outer circumferential wall of the tightening member 208 and female threads are formed in the inner circumferential wall of the ring 209.

The chuck 211 is provided in the tightening member 208 in such a manner that its heads having an opening force are disposed forwardly - (the left-handed side in Fig. 27) of the rear end portion of the tightening member 208, or the tightening portion 208a. The rear end portion of the chuck 211 is coupled to a lead case 212. The spare leads 214a in the lead case 212 are fed to the tapered front end surface 212a inside the lead case 212 so that they can enter into the chuck 211 one by one. The rear end portion of the lead case 212 is press-fitted into the rear step 202c formed on the inner surface of the rear end portion of the

rear holder 202 so that the lead case 212 is fixedly secured to the rear holder 202. The lead case 212 and the rear holder 202 may be formed as one unit, as a result that the number of components of the mechanical pencil is decreased. An eraser 213 is detachably attached to the rear end portion of the rear holder 202. With the eraser 213 removed from the rear holder 202, leads 214 can be supplied into the lead case 212.

In the condition shown in Fig. 27, the tightening portion 208a is disposed at the rear side (to the right-handed side of Fig. 27) from the heads 211a of the chuck 211. In this condition, the lead 214 is released from being clamped since the heads 211a of the chuck open by its own opening force. The lead 214 is held by the lead holding member 205. The lead can readily be retracted by pushing the tip end of the lead 214 against the finger tip or a sheet, as shown in Fig. 27, if the lead 214 extends out of the tip end of the lead pipe 201b. In the condition shown in Fig. 27, the sliding member 204 is urged backwardly by the elastic force of the spring 206 until the sliding member 204 comes into abutment with the stop 210, and the pinching members 203 are restored by its own restoring force and by the elastic force of the spring 206 through the sliding member 204.

The operation of the mechanical pencil shown in Fig. 27 will be described with reference to Figs. 28 through 32.

Fig. 22 shows the mechanical pencil whose pinching members 203 are depressed by the fingers to thereby come the sliding member 204 into abutment with the ring 209. In this condition, a slight forward movement of the front end of the pinching members 203 causes the sliding member 204 to move forwardly while pressing the spring 206. In this case, the tightening member 208 does not move since the legs of the sliding member 204 merely pass through the slit 201c of the tightening member 208. Therefore, the lead 214 which is not clamped by the chuck 211 but held by the lead holding member 205 moves forwardly to extend from the tip end of the lead pipe 201b by the length l which is the same as the moving distance of the sliding member 204.

Fig. 29 shows the mechanical pencil in which the pinching members 203 are further depressed by the fingers to cause the sliding member 204 to further move forwardly. The sliding member 204 further pushes the spring 206 and further moves forwardly from the condition shown in Fig. 28. In this condition, the tightening member 208 moves forwardly by the sliding member 204 through the ring 209 so that the tightening portion 208a tends to engage with the heads 211a of the chuck 211, while the lead 214 slightly moves forwardly from the position shown in Fig. 28 to extend from the tip

end of the lead pipe 201b by the length through which the sliding member 204 moves forwardly.

Fig. 30 shows the mechanical pencil in which the pinching members 203 are completely depressed to thereby obtain the writing condition. The sliding member 204 can move forwardly against the elastic force of the spring 206. However, the ring 209 and the tightening member 208 no longer move forwardly. Accordingly, there is a distance between the sliding member 204 and the step 201d of the front holder's front end portion 201a. That is, the tightening portion 208a is completely engaged with the chuck 211 to clamp the lead 214. Thus, the tightening part 208a can no longer move forwardly because the heads 211a of the chuck 211 have a large diameter in proportion to the movement of the tip end. Accordingly, also the tightening member 208 cannot move forwardly any longer. The lead 214 cannot move forwardly any longer from the position shown in Fig. 29 while the lead holding part 205 moves forwardly together with the sliding member 204, relative to the lead 214 which is clamped by the chuck 211.

Fig. 31 shows a mechanical pencil in which the pressure exerted to the pinching members 203 is slightly decreased, after the lead extending from the tip end of the lead pipe 201b is worn out by the afore mentioned length l , until the legs of the sliding member 204 come into abutment with the stop 210. In this condition, the tightening member 208 does not move backwardly since the legs of the sliding member 204 merely pass through the slits 208b of the tightening member 208. Therefore, the lead 214 is still clamped by the chuck 211 while the heads 211a thereof are engaged with the tightening portion 208a. The lead holding member 205 moves backwardly relative to the lead 214 by the distance l . The distance l is just a length through which the lead 214 relatively moves forwardly (a lead extending length for one pinching operation).

Fig. 32 shows the mechanical pencil in which the pressure exerted to the pinching members 203 is completely decreased from the position where the mechanical pencil is held as shown in Fig. 31. In this condition, the sliding member 204 moves backwardly by the elastic force of the spring 206 until the sliding member 204 comes into abutment with the stop 207. The pinching members 203 are restored by its own restoring force and also by the sliding member 204 moving backwardly by the spring 206. The tightening member 208 moves backwardly by the legs of the sliding member 204 through the stop 210. As a result, the tightening member 208a is disengaged from the heads 211a of the chuck 211. In this operation, the tightening part 208 is flicked back to the position where the ring 209 abuts against the legs of the sliding mem-

ber 204 by the opening force of the heads 211a of the chuck 211; however it is returned immediately by its own weight as shown in Fig. 32. Upon the movement from the condition shown in Fig. 31 to that shown in Fig. 32, the lead 214 slightly moves backwardly, by the holding force of the lead holding member 205 just after the heads 211a of the chuck 211 open, by the distance through which the lead moves forwardly on moving from the condition shown in Fig. 28 to that shown in Fig. 29. Therefore, the length of the lead extending out of the tip end of the lead pipe 201b shown in Fig. 31 moves backwardly until the tip end of the lead 214 is flush with the end of the lead pipe 201b as shown in Fig. 32. Accordingly, the condition shown in Fig. 32 is the same as that shown in Fig. 27 with the exception that the lead is shortened by the lead worn out distance (the distance l in the figures).

In the foregoing embodiment, in the condition shown in Fig. 28 to that shown in Fig. 29, or that shown in Fig. 31 to that shown in Fig. 32, there is almost no or no forward or rearward movement of the lead. This movement of the lead is varied according to the holding force of the lead holding member, the configurations and the materials of the heads of the chuck and the tightening portion of the tightening member and the condition of the engagement with each other.

In the condition shown in Fig. 32, when the pinching members 203 are pressed by the fingers again, the condition are repeated along the line shown in Figs. 28 to 30, and finally, the writing condition can be obtained.

Fig. 33 is a longitudinal sectional view of a mechanical pencil according to still another embodiment of the invention. The mechanism shown in Fig. 33 is substantially the same as that shown in Fig. 27 except that the lead case 212 is not fixedly secured to the rear holder 202 while elastically connected to the rear holder 202 by a spring 215. More specifically, the spring 215 for moving the lead case backwardly is provided between a protrusion disposed at the rear side of the lead case 212 and a spring stop ring 202d fixedly secured to the inner wall of the rear holder 202, so that the lead case 212 is always urged to the rear side (to the right-handed side of Fig. 33) to thereby support the lead case 212 which is urged toward the rear step portion of the rear holder 202. The elastic force of the spring 215 for moving the lead case backwardly is stronger than that of the spring 206 for moving the sliding member backwardly. In this embodiment, if the pinching members are depressed with a strong force, the tightening member 208, the chuck 211 and the lead case 212 can further move forwardly beyond the position in the previous embodiment shown in Fig. 30, after the tightening portion 208a of the tightening member

208 is engaged with the heads of the chuck 211 while further compressing the spring 215 for moving the lead case backwardly.

Fig. 34 shows a longitudinal sectional view of the mechanical pencil according to another embodiment of the invention. In this embodiment, a sliding pipe 220a and a sliding member 220 having therein a sliding member holding part 220b are provided in a front holder's front end portion. In the condition shown in Fig. 34, after the lead extending out of the tip end of the sliding pipe 220a is worn out during writing, the writing operation can be continued while the sliding member 220 moves backwardly by the writing pressure, because the lead is always protected by the sliding pipe 220a. However, when the lead is desired to extend to the position shown in Fig. 34, it is necessary to repeatedly press and release the pinching members 203.

Fig. 35 is a longitudinal sectional view showing essential component of the mechanical pencil according to another embodiment of the invention. In this embodiment, a cap 221 having an eraser 213 at the rear end thereof is disposed at the rear end of the rear holder 202 instead of the eraser 213 disposed directly on the rear holder 202. A bolt 222 is provided inside of the cap 221. Threads in the rear portion of the rear holder 202 are engaged with threads formed in the front portion of the bolt 222. The lead 214 and the space leads 214a are inserted into the lead case 212 from the rear opening of the rear holder 202 in such a manner that the bolt 222 is detached from the rear holder 202. According to this embodiment, the cap 221 is detachable from the rear side of the mechanical pencil body and can be mounted on the front holder of the pencil so as to prevent the lead pipe from being broken down when the pencil is dropped. This also eliminates fears that the tip end of the lead pipe would damage the user's pocket and that the lead extending from the tip end of the lead pipe would make the pocket dirty, when the mechanical pencil is not in use or carried. At that time, the inner surface of the mechanical pencil urges the pinching members 203 to produce an elastic force. Therefore, a good feeling can be obtained when the cap is capped to the front side of the mechanical body, just like a feeling in case of a fountain pen.

While the above embodiments of the invention have been described, the invention is not limited thereto or thereby. That is, any mechanism in which the pinching members are not deformed when it is held between the fingers, and the sliding member is moved by a cam operation between a cam surface provided on the inner side of the pinching members and an opponent cam surface provided on the outer side of the sliding member may be employed. Further, the spring 106 may be

dispensed with if the pinching members themselves have a relatively strong restoring force and a tip ends of the pinching members are connected to the sliding member. Furthermore, in the aforementioned embodiment shown in Fig. 26, the spring from moving backwardly the lead case may be dispensed with while the lead case and the rear holder are secured to each other or formed as one unit, since the lead case would not move forwardly. However, if the sliding member moves forwardly together with the chuck clamping the lead, the tightening member and the tightening member receiving member when the pinching members are entirely depressed by the fingers, the spring for moving backwardly the lead case may come to be necessary. In such a case, the lead case moves forwardly by depressing the spring. Furthermore, the stopper may be eliminated while the front end of the slit of the front holder is arranged to be the same position with the stop so that the sliding member can be prevented from moving backwardly by abutting it against the tip end of the opened chuck. In the other case, the sliding member may be disposed inside of the front holder, the pinching members may be covered by the elastic members such as rubbers. It may further be possible that the tightening member and the tightening member stop ring may be formed as one unit, and the tightening member and the sliding member may be formed as one unit. In addition, various changes and modification may be made in the above-described embodiments without departing from the invention.

A lead clamping mechanism which permits the forward movement of the lead but not the backward movement can be obtained without employing an intricate and expensive mechanism requiring a ball.

A stable writing operation can be obtained since the lead can extend at a required length during writing.

Fig. 36 is a longitudinal sectional view of a mechanical pencil according to another embodiment of the invention. More specifically, Fig. 36 shows the mechanical pencil which is not in use with its pinching member released.

In Fig. 36, reference numeral 301 designates a front holder; and 302, a rear holder. These holders are coupled to each other to form a mechanical pencil body. The front holder 301 has a front holder front portion 301a at the front end. A lead pipe 301b is press-fitted into the front end portion 301a. The provision of the lead pipe 301b is not always required; that is, the core pipe 301b may be eliminated by sharpening the tip end of the front end portion 301a. One or three slits 301c (three slits in Fig. 31) extend rearwardly from the front end portion 301a of the front holder 301. One or plural pinching members 303 (three pinching members in Fig. 36) are provided with their rear ends

abutting against the front step 302a of the rear holder 302. More specifically, the rear ends of the pinching members 303 are inserted into the front end portion 302b of the rear holder; in other words, the rear ends are connected to one another through an annular part, and the annular part is fitted into the rear holder's front end portion 302b. Each of the pinching members 303 has a hinge part 303a at the central portion. The front ends of the pinching members 303 are inserted into the bottomed holes formed in the rear end portion 304a of a sliding member 304. The sliding member 304 has a cylinder 304b at the center which is coupled through one or plural legs (three legs in Fig. 36) passing through the slits 301c of the front holder 301 to the sliding member 304. A lead holding member 305 made of an elastic material such as a rubber is provided in the cylinder 304b so that it is positively held in the cylinder 304b. A spring 306 is interposed between the step portion provided on the inner surface of the front holder's front end portion 301a and the legs of the sliding member 304 so as to urge the sliding member 304 backwardly (to the right-handed side of Fig. 36). A tightening member 307 is fixedly secured to the mechanical pencil body at the rear portion of the sliding member 304. The inner rear surfaces of the tightening member 307 is arranged to be circular cone shapes 308. The sliding member 304 is prevented from moving backwardly by abutting against the front surface of the tightening member 307. A chuck 309 having heads 309a is provided on the rear side of the tightening member 307, and the rear side of the chuck 309 is formed to be a cylindrical portion 309b which is press-fitted into a lead guide 310. The lead guide 310 itself forms of the front end portion of the lead case 311. One or plural (three in Fig. 36) coupling rods 312 protrude from the slide 304. The coupling rods 312 and the sliding member 304 are formed as one unit, and the rear end portion of the coupling rods urge the lead case 311 rearwardly. In Fig. 36, two of three coupling rods 312 are arranged alternately with protrusions 310a of the lead guide 310. These protrusions 310a pass through slits 312c of the coupling rods 312. The other one of the coupling rods 312 passes through a slit of the protrusion 310a or through a passing hole 310b. A stop ring 313 is fixedly connected to the rear peripheral portion of the coupling rods 312 so as not to slip off forwardly the sliding member 304 from the lead guide 310 and as to produce a gap (length l) between the rear end surface of the protrusions 310a of the lead guide 310 and the front end surface of the stop ring 313. That is, the rear end portion of the coupling rods 312 is axially movable between the rear surfaces of the protrusions of the lead guide 310 and the protrusions of the lead case

311 (which corresponds to the front end surfaces of the lead case 311). Protrusions 311a are disposed on the outer rear peripheral surfaces of the lead case 311, which abut against step portions 302c provided at the inner rear portion of the rear holder 302. However, these protrusion 311b may be eliminated, while the chuck, the lead guide and the lead case move backwardly by the distance l , when the front tip end of the mechanical pencil body is turned up. Reference numeral 314 is an eraser; and 315 is a lead. The eraser 314 is detachably fitted in the rear portion of the rear holder 302, so that the lead 315 and the spare leads are inserted into the lead case 311 through a rear end opening of the rear holder 302.

Next, the operation of the mechanical pencil held as shown in Fig. 36 will be described. In the condition shown in Fig. 36, the lead case 311 is urged backwardly by the coupling rods 312 of the sliding member 304 which is urged backwardly by the spring 306, thus, the chuck 309 is urged backwardly since the chuck 309 is connected to the lead case 311 through the lead guide 310. In this condition, the heads 309a of the chuck 309 open by its own opening force in a space against the circular cone shape portion of the tightening member 307. Accordingly, the lead is not clamped by the heads 309a of the chuck 309 but held by the lead holding member disposed inside of the sliding member 304 with a certain force. In the condition shown in Fig. 36, the front end of the lead 315 is flush with the end of the lead pipe 301b. The above-described gap provided between the rear end surfaces of the protrusions 310a of the lead guide 310 and the front surfaces of the stopper ring 313 will now be represented by l .

Fig. 32 shows the mechanical pencil in which the pinching members 303 are slightly depressed by the fingers. That is, the pinching members 303 are depressed to the radial direction that the front end of the pinching members slightly move forwardly. As a result, the sliding member 304 moves forwardly against the elastic force of the spring 306, by the front end of the pinching members 303 while the stop ring 313 moves forwardly through the coupling rods 312, so that the stop ring 313 comes into contact with the protrusions 310a of the lead guide 310. The lead 315 extends from the tip end of the lead pipe 301b by the distance l , while being held by the lead holding member 305, while the chuck 309 is still.

Fig. 38 shows a mechanical pencil in which the pinching members 303 are further depressed by the fingers under the condition that the mechanical pencil is held as shown in Fig. 37. In this condition, the lead guide 310, the chuck 309 and the heads 309a of the chuck 309 move forwardly through the stopper ring 313, together with the sliding member

304 so that the heads 309a of the chuck 309 are caused to go into the circular cone shaped portion 308 of the tightening member 307 to engage the tightening member 307 with the heads 309a of the chuck 309. In this condition, the lead 315 is completely clamped by the heads 309a of the chuck 309 so that the writing operation can be performed.

Fig. 39 shows the mechanical pencil in which the pressure applied to the pinching members 303 is slightly decreased under the condition that the mechanical pencil is held as shown in Fig. 39. In this condition, the sliding member 304 moves backwardly by the elastic force of the spring 306 so that the rear end portion of the coupling rods 312 comes into contact with the front end surface of the lead case 311. In the movement from the condition shown in Fig. 38 to that shown in Fig. 39, the sliding member 304 moves backwardly by the distance l which corresponds to the afore-described gap, thus, the lead holding member 305 moves backwardly by the same distance. The lead 315, on the other hand, does not move being kept clamped by the heads 309a of the chuck 309 engaged with the tightening member 307. Therefore, while the lead holding member 305 moves backwardly against the lead 315, the distance which the lead 315 moves forwardly relative to the lead holding member 305 or the sliding member 304 is a lead extending length of the mechanical pencil of the present invention, and this distance is arranged to be l . The lead is prevented from moving backwardly during the above-described operation.

Fig. 40 shows the mechanical pencil in which the pressure exerted on the pinching members 303 is completely decreased. In this condition, the sliding member 304 moves backwardly by the elastic force of the spring 306 so that the sliding member 304 comes into contact with the front end of the tightening member 307. The lead case 311, the lead guide 310 and the chuck 309 also move backwardly by the coupling rods 312. The heads 309a of the chuck 309 open by its own opening force to release the clamping of the lead 315. The condition shown in Fig. 40 is entirely same as that shown in Fig. 36 with the exception that the lead 315 extends from the tip end of the lead pipe 301b by the distance l .

In the condition shown in Fig. 40, if the lead further extends by the distance l by depressing the pinching members 303 and the total extending length of the lead 315 may be too long to write, the lead can readily be retracted by pushing the tip end of the lead 315 against a finger tip or a sheet while releasing the pressure to the pinching members 303. That is, the condition is once returned to that shown in Fig. 36, then, the writing operation

can be obtained when pressing the pinching members 303 again.

Fig. 41 is a longitudinal sectional view showing essential components of a mechanical pencil which is a thirteenth embodiment of the invention. In Fig. 41, a stop 316 for preventing the backward movement of the sliding member 304 is press-fitted at the inner surface of the front holder 301. A tightening member 307 is provided with an extending part 307a at the rear side thereof. A stop ring 317 is press-fitted to the outer rear peripheral side of the extending part 307a. A stop 318 is press-fitted to the inner peripheral surface of the front holder 301 at the rear side of the stop ring 317. A spring 319 is disposed between the stopper 316 and the stop ring 317. In this condition shown in Fig. 41, the tightening member 307 is slidable and always urged rearwardly.

According to the above-described embodiment, the tightening member 307 can move forwardly together with the heads 309a of the chuck 309 against the elastic force of the spring 319, after the heads 309a of the chuck 309 are completely engaged with the tightening member 307 to perfectly clamp the lead 15 by the heads 309a of the chuck 309, while pressing the pinching members 303. Therefore, a radial movement of the pinching members 303 can be obtained after the lead 15 is completely clamped. Thus, this mechanism produces a buffer members for absorbing the excessive force to the pinching members 303. The spring 319 for the buffer means must have a sufficient strength enabling to keep the lead 315 being clamped by the heads 309a of the chuck 309 engaged with the tightening member 307. However, if the force of the spring 319 is too strong, the operation would be the same as that shown in Fig. 36 in which the tightening member 307 is fixedly secured.

While few embodiments of the invention have been described, the invention is not limited thereto or thereby. That is, any mechanism in which the pinching members are not deformed when held between the fingers, and the sliding member moves by a cam operation between a cam surface provided on the inner side of the pinching members and an associated cam surface provided on the outer side of the sliding member may be employed. Further, the cam surface can be provided merely on one side and the associated surface is provided with a protrusion instead of the cam portion. The spring for moving the sliding member backwardly may be eliminated while the front end of the pinching members are connected to the sliding member and the pinching members have its restoring force. Furthermore, in the mechanical pencil of the last embodiment of the invention, the tightening member function as a stop member from

preventing the sliding member for moving backwardly. However, a stop which is separated from the tightening member may be employed. Two or plural higher portions may be arranged on one pinching members. Further, a leaf spring with arched-shape may be employed as a pinching member

Claims

1. A mechanical pencil comprising:

a hollow elongated body having at least one axial slit at its normal gripping portion which is naturally gripped by writer's fingers;

chuck means for chucking and releasing a lead, said chuck means having a plurality of heads and a rear portion, said chuck means being subjected to a self-opening force urging said plurality of heads to open outwardly;

chuck tightening means for closing said heads of said chuck means, said chuck tightening means being disposed on a rear side of said heads of said chuck means, at least one pinching member disposed along said axial slit, said pinching member being secured at its first end to said body;

lead holding means for normally holding said lead with a predetermined holding force, said lead holding means being disposed on a front side of said heads of said chuck means; and

translating means for translating a radial shift of said pinching member into a linear axial movement between said chuck tightening means and said chuck means;

wherein said chuck means moves at a predetermined distance relative to a position where the lead is clamped by said chuck means, and said lead is caused to extend from a frontmost end of said body by the cooperation among said pinching member, said chuck means, said lead holding means, said chuck tightening means and said translating means, without changing a writer's writing finger position.

2. A mechanical pencil comprising:

a hollow elongated body having at least one axial slit at its normal gripping portion which is naturally gripped by writer's fingers;

chuck means for chucking a lead when said chuck means moves backwardly and releasing said lead when said chuck means moves forwardly, said

chuck means having a plurality of heads and a rear portion, said chuck means being subjected to a self-opening force urging said plurality of heads to open outwardly, said chuck means being always urged forwardly;

chuck tightening means for closing said heads of said chuck means, said chuck tightening means being disposed on a rear side of said heads of said chuck means;

at least one pinching member disposed along said axial slit, said pinching member being secured at its first end to said body;

lead holding means for normally holding said lead with a predetermined holding force, said lead holding means being disposed on a front side of said heads of said chuck means; and

translating means for translating a radial shift of said pinching member into a linear axial movement between said chuck tightening means and said chuck means;

wherein said chuck means moves at a predetermined distance relative to a position where the lead is clamped by said chuck means, and said lead is caused to extend from a frontmost end of said body by the cooperation among said pinching member, said chuck means, said lead holding means, said chuck tightening means and said translating means, without changing a writer's writing finger position.

3. A mechanical pencil comprising:

a hollow elongated body having at least one axial slit at its normal gripping portion which is naturally gripped by writer's fingers;

chuck means for chucking and releasing a lead, said chuck means having a plurality of heads and a rear portion, said chuck means being subjected to a self-opening force urging said plurality of heads to open outwardly, said chuck means being substantially fixed to said body;

chuck tightening means for closing said heads of said chuck means, said chuck tightening means being disposed on a rear side of said heads of said chuck means, at least one pinching member disposed along said axial slit, said pinching member being secured at its first end to said body;

lead holding means for normally holding said lead with a predetermined holding force, said lead holding means being disposed on a front side of said heads of said chuck means;

translating means for translating a radial shift of said pinching member into a linear axial movement between said chuck tightening means and said chuck means; and

sliding member disposed on a front side of said chuck means, said sliding member being axially movable at a predetermined distance;

wherein said chuck means moves at a predetermined distance relative to a position where the lead is clamped by said chuck means, and said lead is caused to extend from a frontmost end of said body by the cooperation among said pinching member, said chuck means, said lead holding means, said chuck tightening means, said sliding member and said translating means, without changing a writer's writing finger position.

4. A mechanical pencil of claim 2 or 3, further comprising a hollow lead case disposed within said body, said lead case having a cone-shaped front portion.

5. A mechanical pencil of claim 4, wherein said rear portion of said chuck means is press-fitted to a front portion of said lead case.

6. A mechanical pencil of claim 5, wherein a front end of said body is provided with a substantially cone-shaped end member.

7. A mechanical pencil of claim 6, wherein said end member of said body comprises a step portion at inside for preventing a forward movement of said chuck tightening means.

8. A mechanical pencil of claim 6, wherein said body comprises a front holder and a rear holder coupled to said front holder.

9. A mechanical pencil of claim 6, further comprising a coupling means for coupling said end member of said body to said body.

10. A mechanical pencil of claim 6, further comprising a lead piping member disposed at a frontmost end of said end member.

11. A mechanical pencil of claim 10, further comprising a first ring disposed on an outer surface of said lead case, a step portion formed on an inner surface of said body and on the rear side of said first ring, and a first spring means disposed between said first ring and said step portion.

12. A mechanical pencil of claim 11, further comprising a second ring for preventing a forward movement of said lead case by abutting against said first ring.

13. A mechanical pencil of claim 10, wherein a front end of said heads of said chuck means is in contact with said lead holding means when said pinching member is not pinched.

14. A mechanical pencil of claim 10, wherein said pinching member has a hinge portion.

15. A mechanical pencil of claim 14, wherein an end of said pinching member is ring-shaped.

16. A mechanical pencil of claim 10, wherein said pinching member comprises an elongated leaf spring which is curved outwardly.

17. A mechanical pencil of claim 16, wherein said pinching member is covered by a drum-shaped thin rubber cylinder.

18. A mechanical pencil of claim 10, wherein said pinching member comprises a leaf spring, said leaf spring includes at least one protrusion at a front inner side, wherein said front side of said pinching member is radially movable.

19. A mechanical pencil of claim 18, wherein a front portion of said lead case is slope-shaped.

20. A mechanical pencil of claim 10, wherein said pinching member has a self-restoring force.

21. A mechanical pencil of claim 10, further comprising a second spring means disposed between said rear end of said pinching member and a third ring secured to said lead case, wherein the elastic force of said second spring means is greater than that of said first spring means.

22. A mechanical pencil of claim 10, further comprising a tightening means receiving member disposed on a rear side of said tightening means, said tightening means receiving member preventing the rearward movement of said tightening means.

23. A mechanical pencil of claim 22, further comprising a third spring means disposed on a rear side of said tightening means, said tightening means being urged forwardly by said third spring means, wherein the elastic force of said third spring means is greater than that of said first spring means.

24. A mechanical pencil of claim 10, wherein said lead holding means comprises a rubber.

25. A mechanical pencil of claim 10, further comprising an eraser detachably fixed to a rear end opening of said body.

26. A mechanical pencil of claim 10, further comprising a pipe means, said pipe means disposed between a front portion of said lead case and said rear portion of said chuck means.

27. A mechanical pencil of claim 26, further comprising a rotating means disposed on an inner surface of said pinching member.

28. A mechanical pencil of claim 27, wherein said pipe means is cone-shaped, and said cone-shaped surface of said pipe means is in contact with said rotating means.

29. A mechanical pencil of claim 28, wherein said rotating means comprises a roller.

30. A mechanical pencil of claim 28, wherein said rotating means comprises a ball.

31. A mechanical pencil of claim 26, wherein said inner surface of said pinching member is cone-shaped.

32. A mechanical pencil of claim 31, further comprising a rotating means disposed on an outer surface of said pipe means, said rotating means being connected to an inner surface of said pinching member.

33. A mechanical pencil of claim 32, wherein said rotating means comprises a roller.

34. A mechanical pencil of claim 32, wherein said rotating means comprises a ball.

35. A mechanical pencil of claim 10, wherein said sliding member comprises at least one leg, and said leg passes through said slit.

36. A mechanical pencil of claim 35, wherein a rear end of said leg of said sliding member is provided with a cylindrical outer wall, and said cylindrical outer wall receives a second end of said pinching member.

37. A mechanical pencil of claim 36, wherein said sliding member includes a cylindrical member at a center portion, and said cylindrical member projects forwardly and receives therein said lead holding means.

38. A mechanical pencil of claim 37, further comprising a forth spring means disposed between a step portion at an inner surface of said end member of said body and a front end portion of said sliding member.

39. A mechanical pencil of claim 38, further comprising a forth ring disposed on the inner surface of said body, said forth ring preventing a backward movement of said sliding member.

40. A mechanical pencil of claim 10, wherein said tightening means comprises a tightening member receiving member disposed on a rear side of said sliding member and a tightening member disposed within said tightening member receiving member which is axially movable at a predetermined distance.

41. A mechanical pencil of claim 40, wherein said tightening member receiving member and said sliding member are formed as one unit.

42. A mechanical pencil of claim 40, wherein a forward movement of said tightening member is prevented by said sliding member.

43. A mechanical pencil of claim 40, wherein a forward movement of said tightening member is prevented by a step portion formed on the inner surface of said tightening member receiving member.

44. A mechanical pencil of claim 43, wherein said tightening member includes a tightening portion at a rear portion which is engageable with said heads of said chuck means.

45. A mechanical pencil of claim 10, further comprising a fifth spring means and a fifth ring provided on the inner surface of said body, said fifth spring means being disposed between said fifth ring and a projection formed on an outer surface of said lead case.

46. A mechanical pencil of claim 10, wherein said tightening means comprises a tightening member having a plurality of slit at a front portion.

47. A mechanical pencil of claim 46, wherein said tightening member and said tightening portion are formed as one unit.

48. A mechanical pencil of claim 46, wherein a front end of said tightening member is provided with a stop means which prevents said sliding member from moving forwardly.

49. A mechanical pencil of claim 47, wherein said stop means comprises a ring.

50. A mechanical pencil of claim 47, wherein said stop means comprises a projection of said tightening member.

51. A mechanical pencil of claim 10, wherein said lead piping member is axially slidable.

52. A mechanical pencil of claim 51, wherein said lead piping member includes a second lead holding means.

45

50

55

20

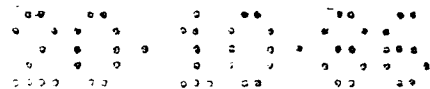

FIG. 1

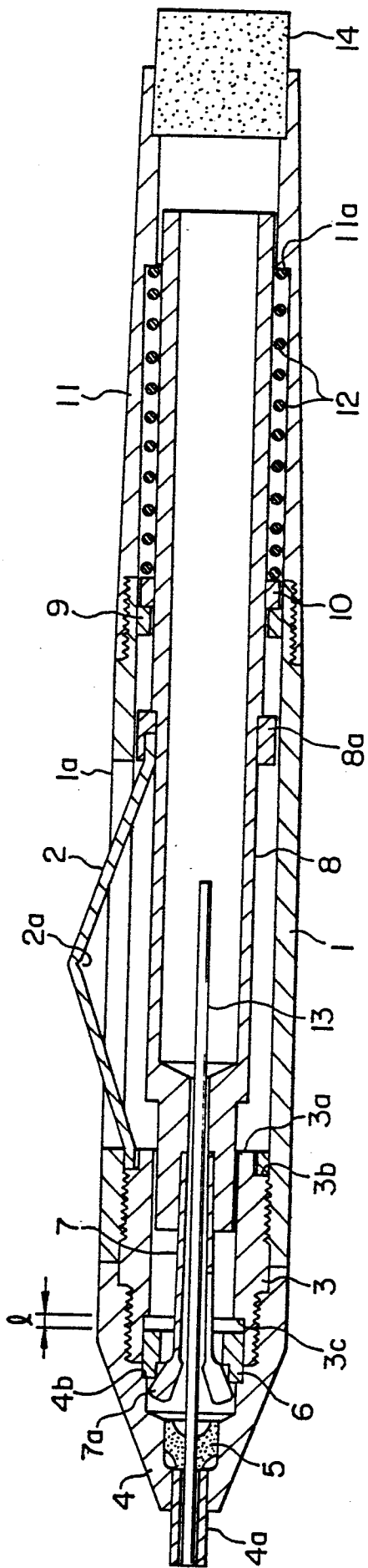
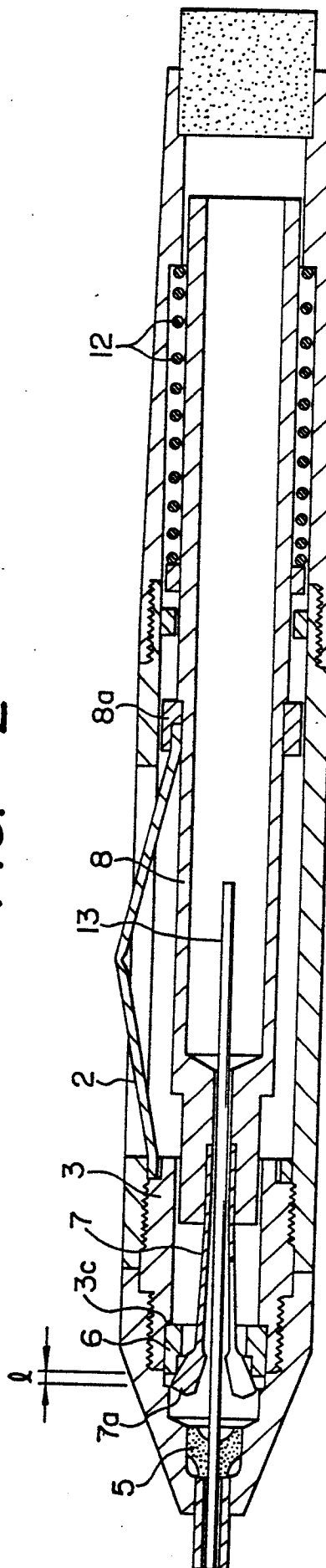

FIG. 2



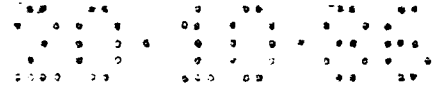

FIG. 3

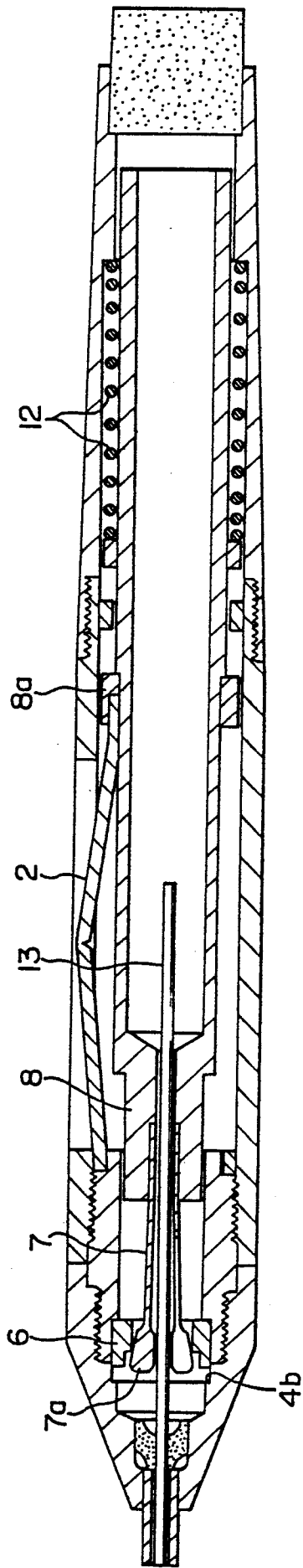
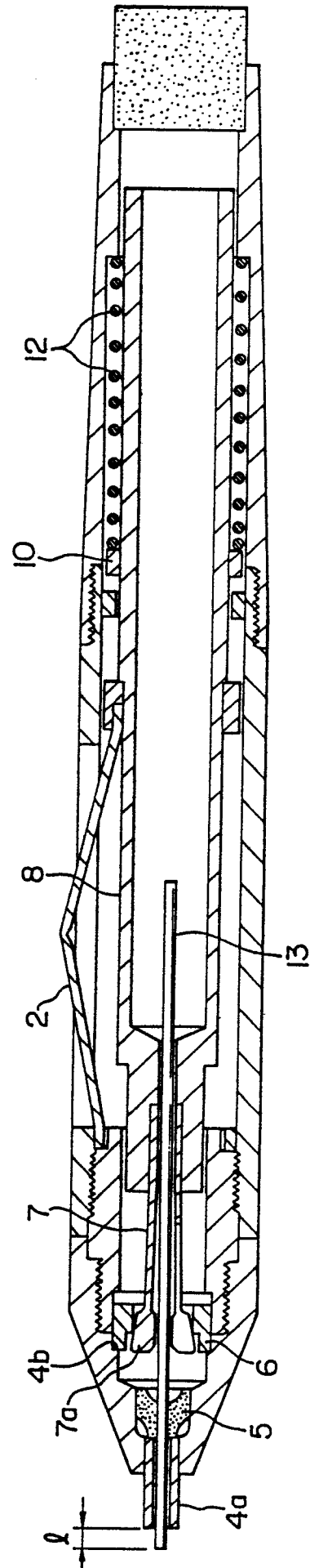

FIG. 4



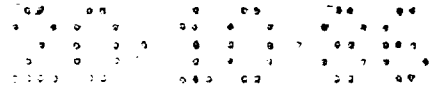

FIG. 5

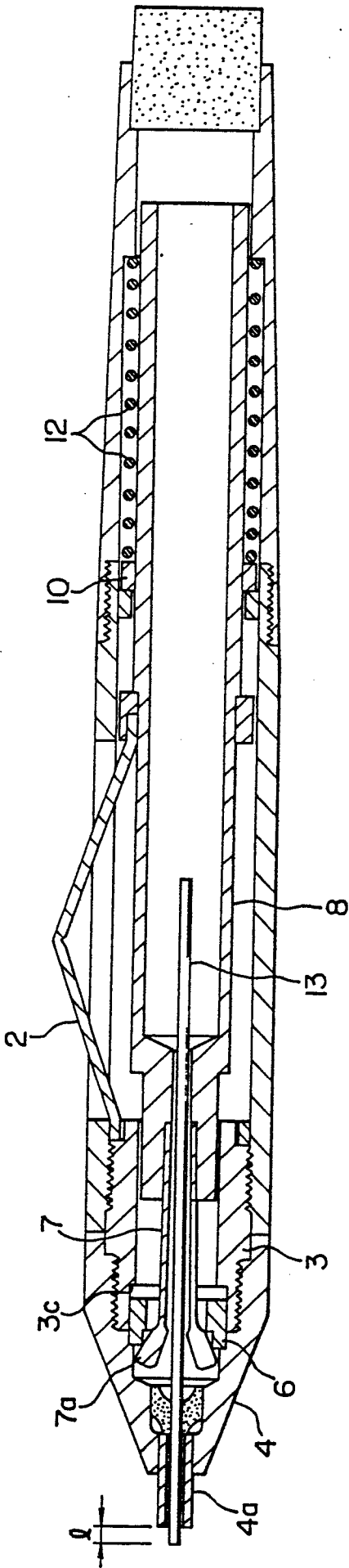
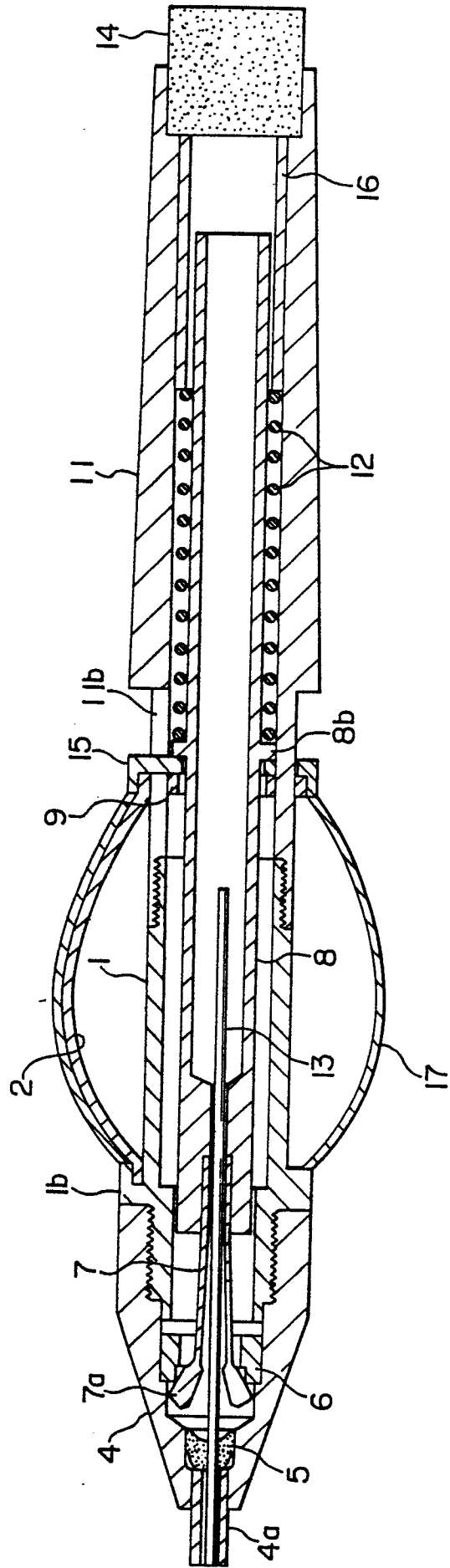

FIG. 6



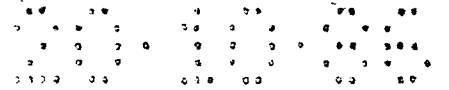

FIG. 7

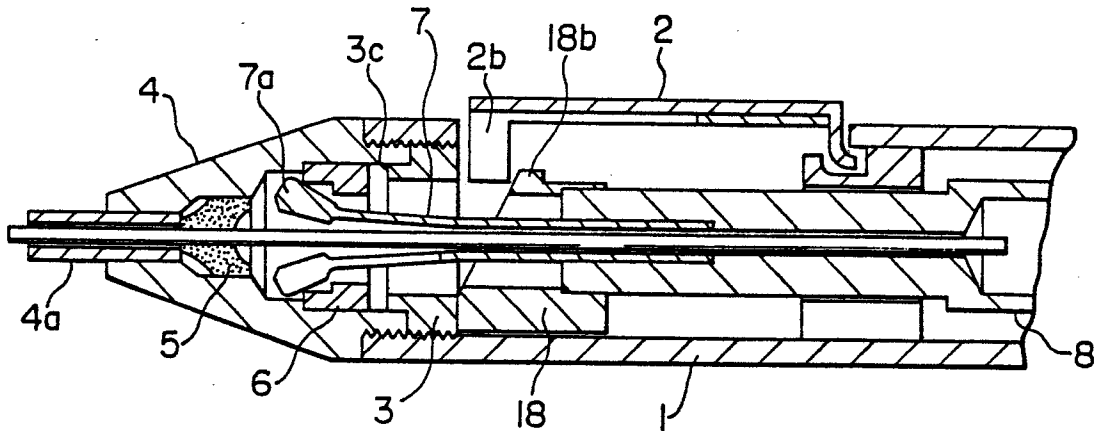
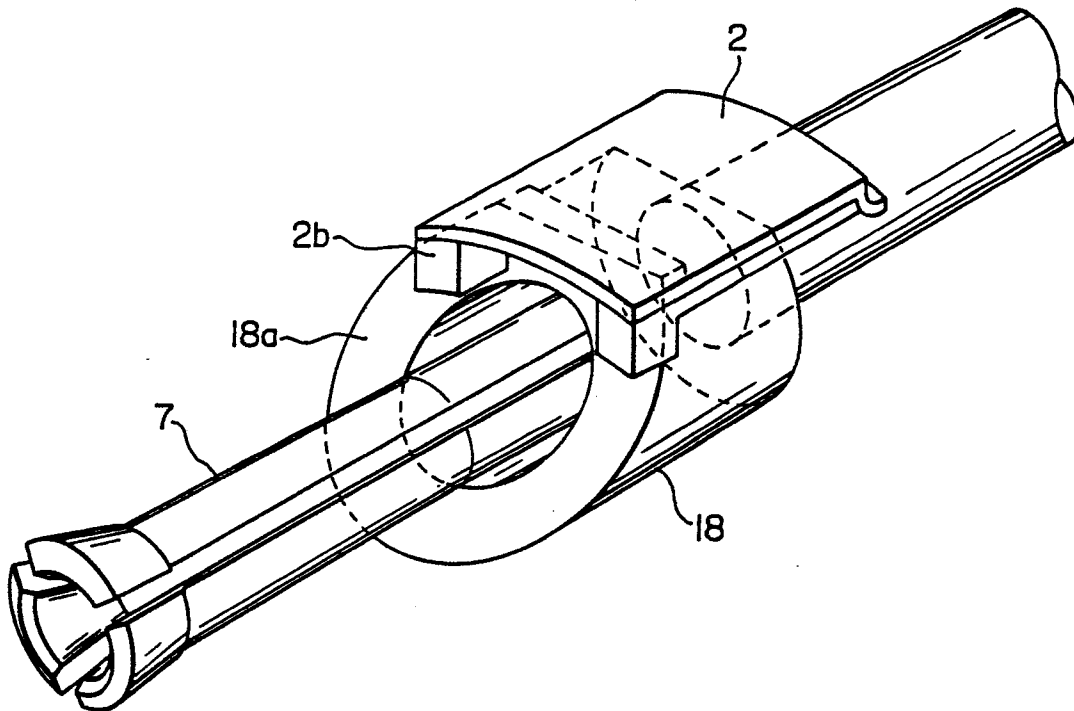

FIG. 8



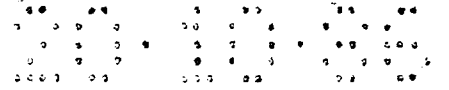

FIG. 9

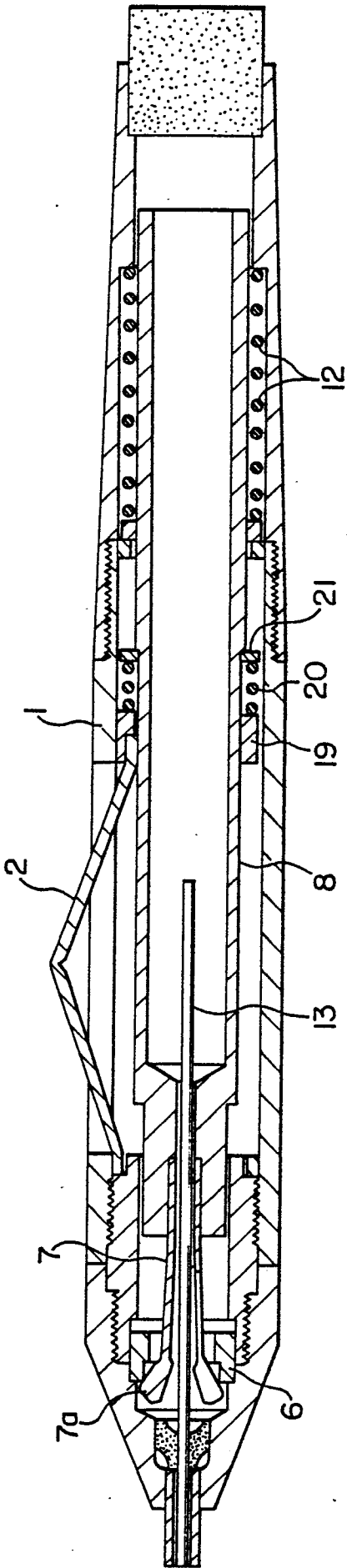
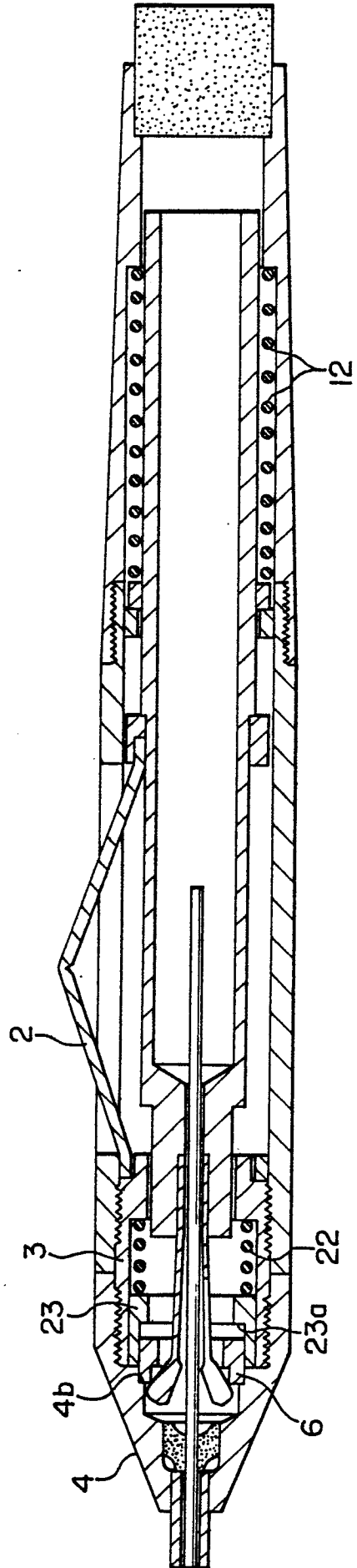

FIG. 10



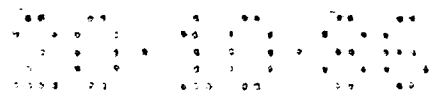

FIG. 11

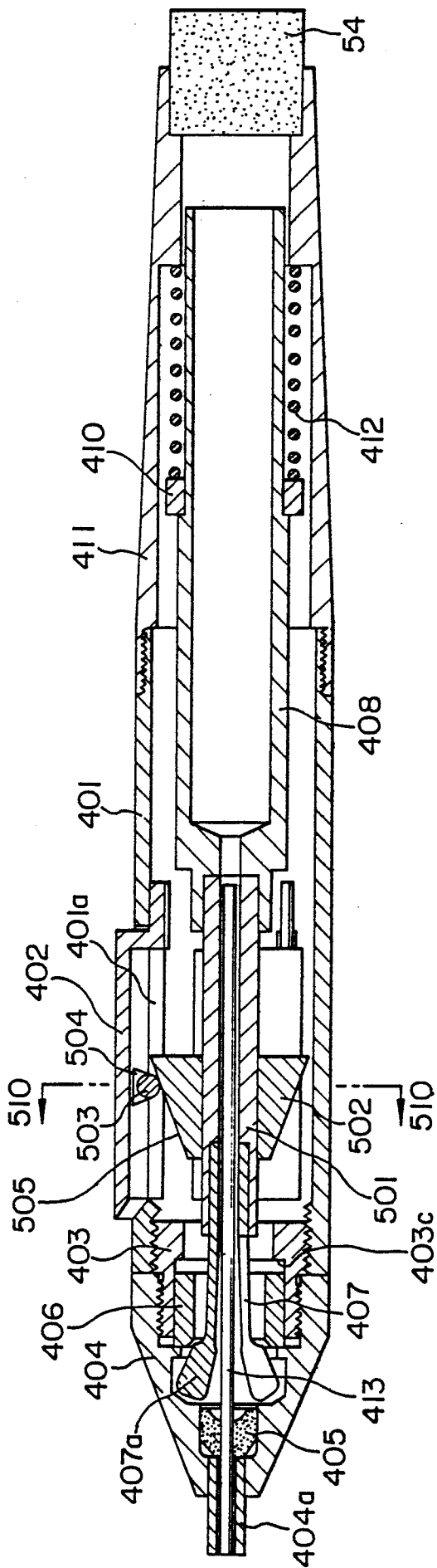
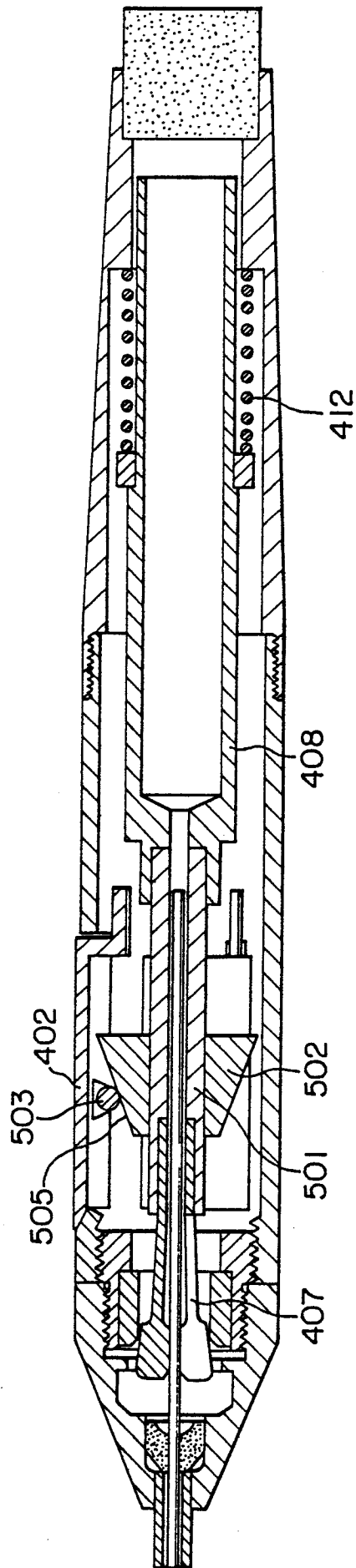

FIG. 12



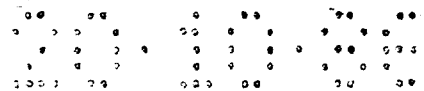

FIG. 13

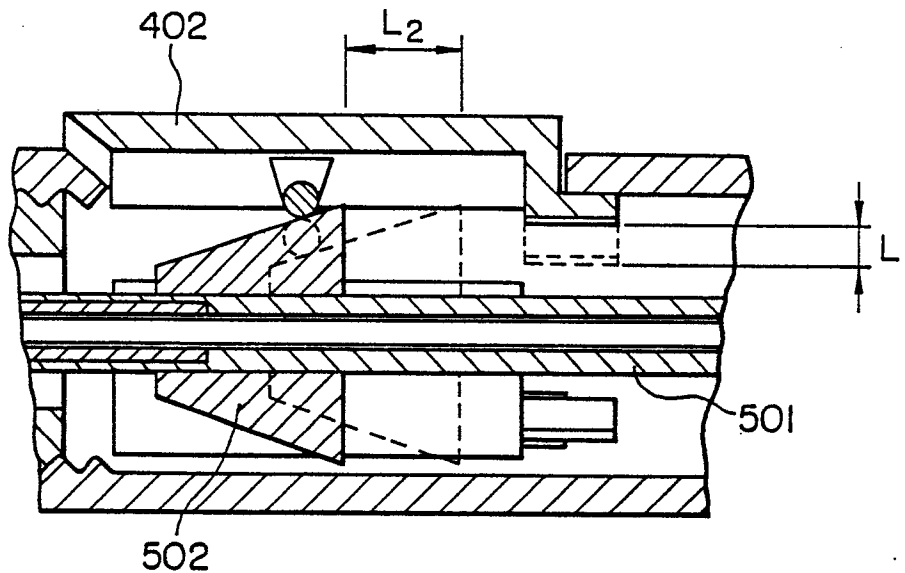

FIG. 14

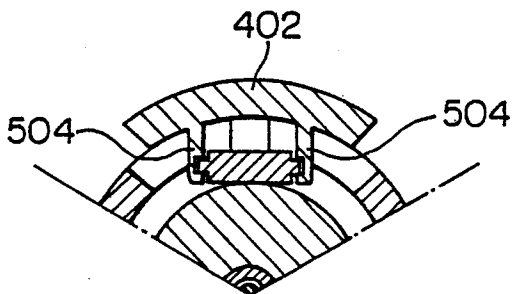

FIG. 15



FIG. 16

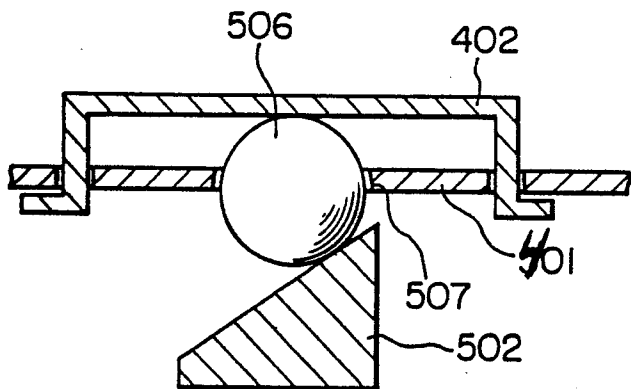
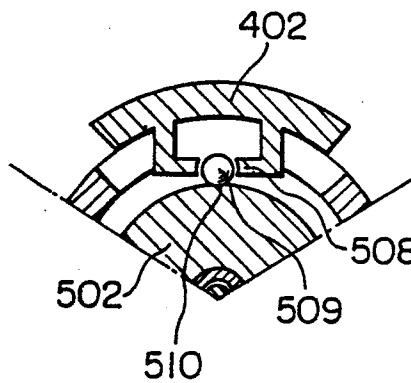

FIG. 17



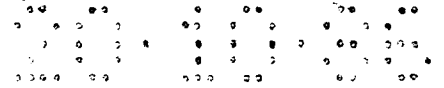

FIG. 18

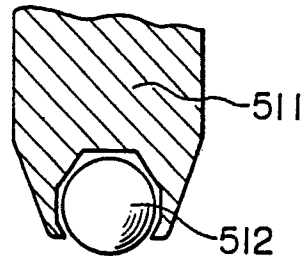

FIG. 19

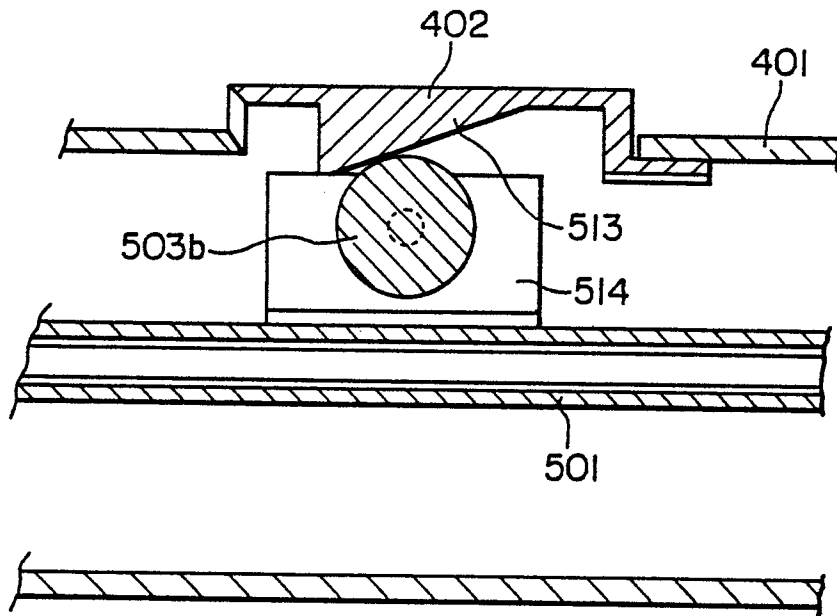
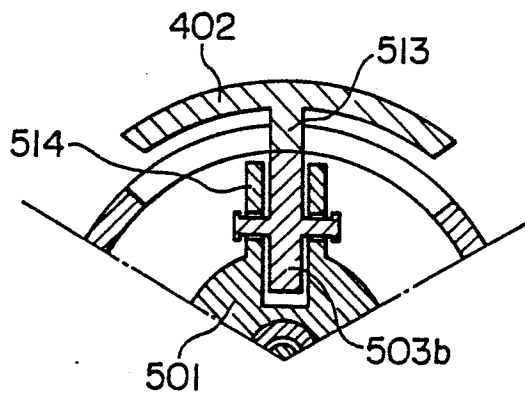

FIG. 20



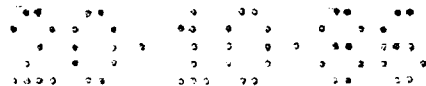

FIG. 21

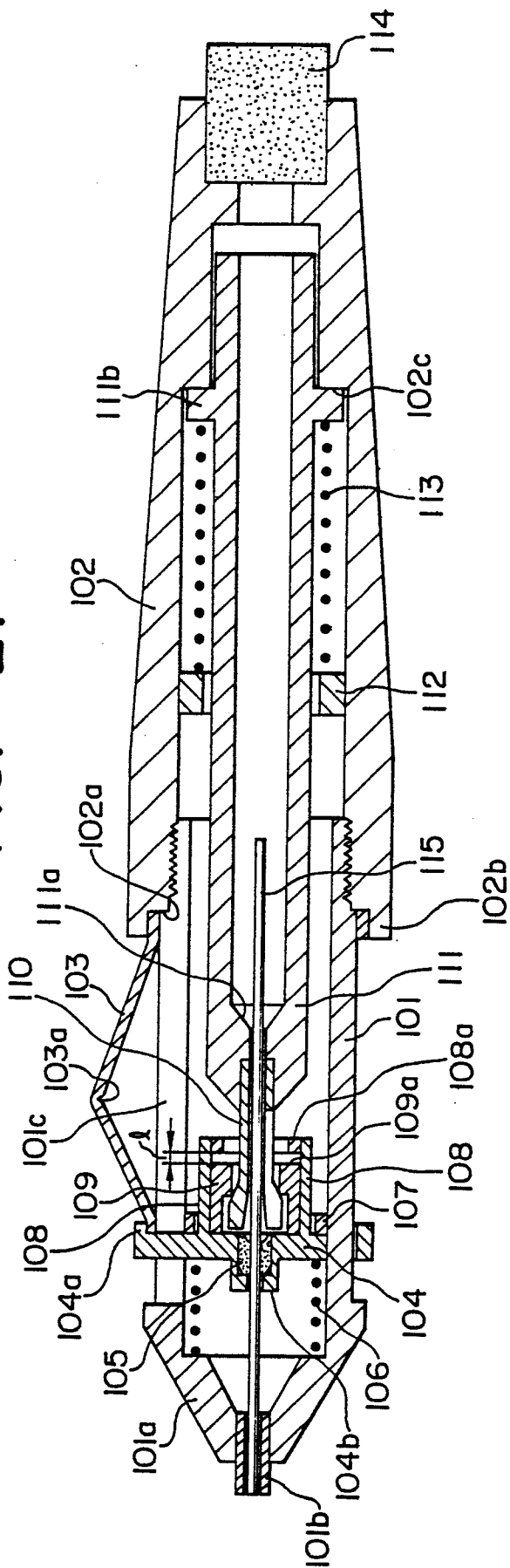
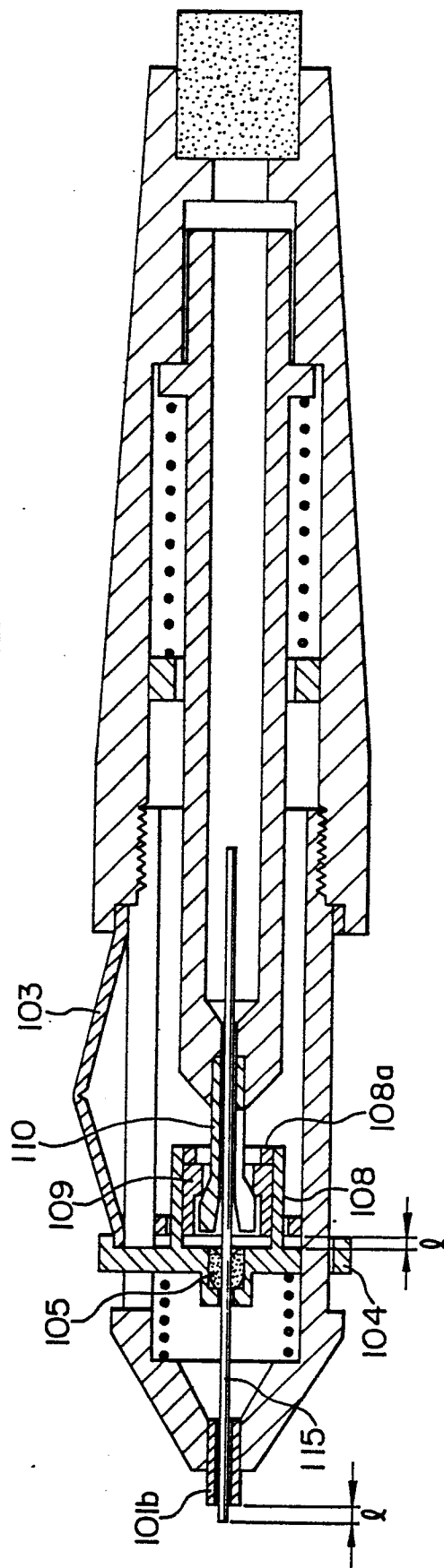

FIG. 22



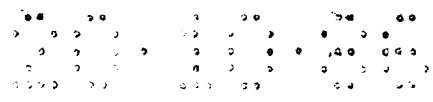

FIG. 23

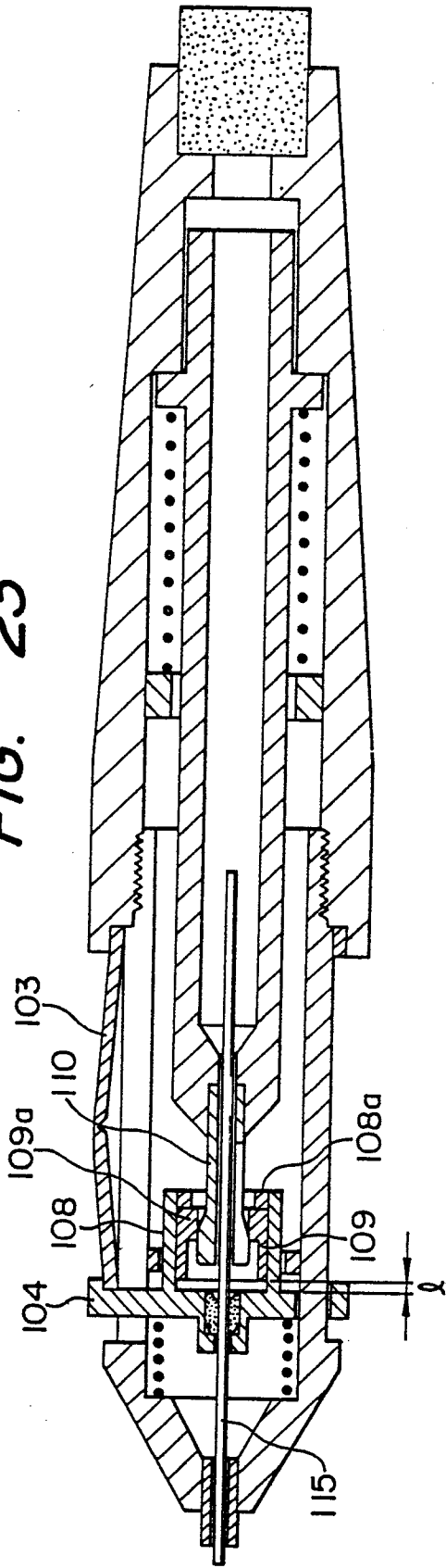
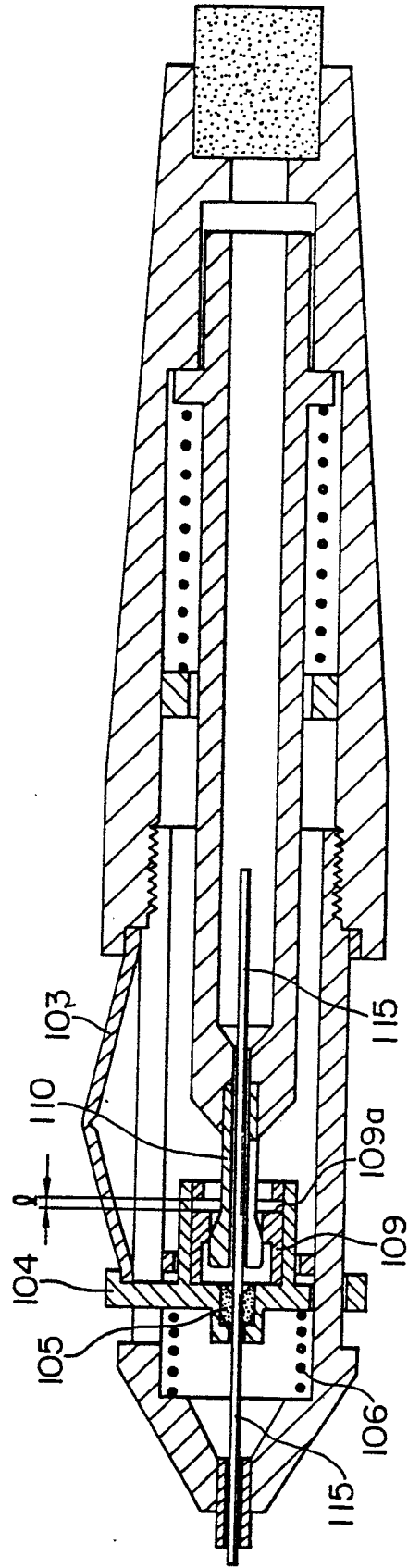

FIG. 24



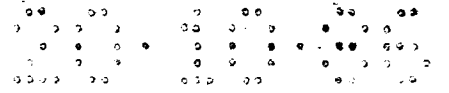

FIG. 25

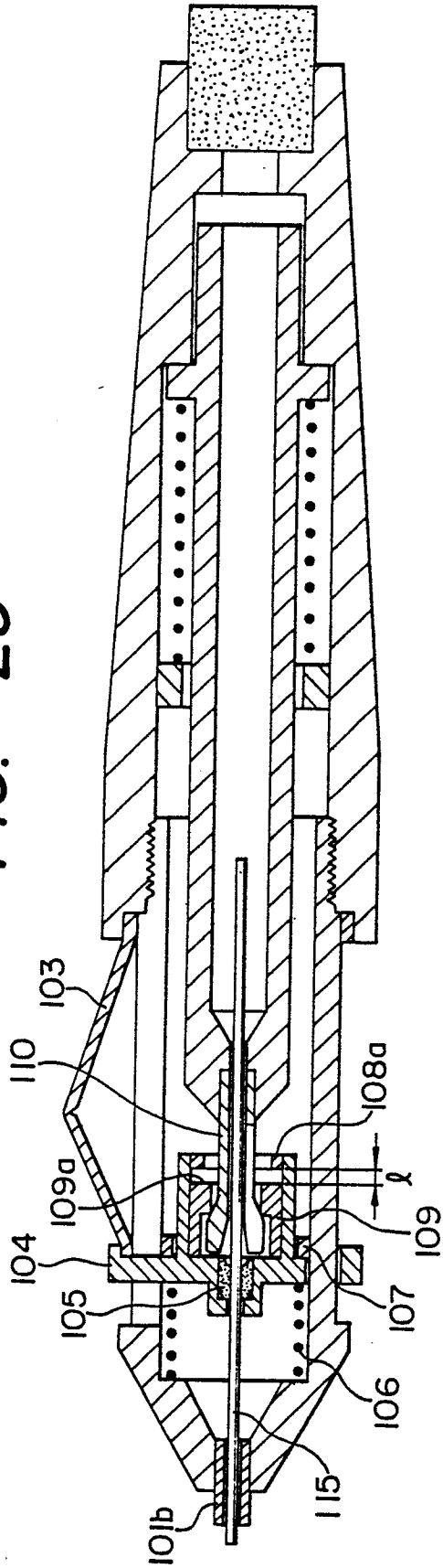
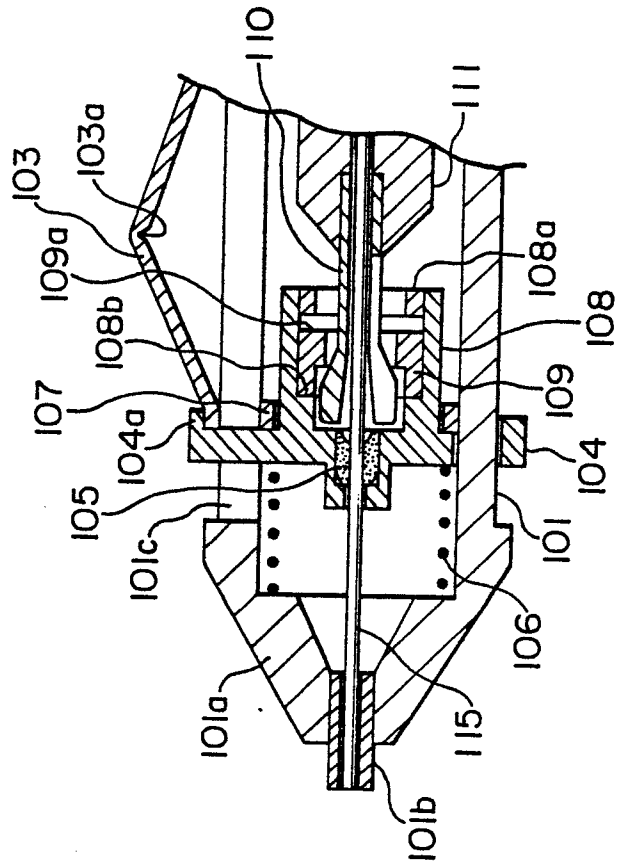

FIG. 26



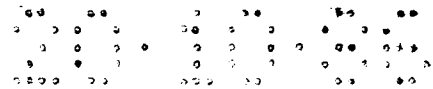

FIG. 27

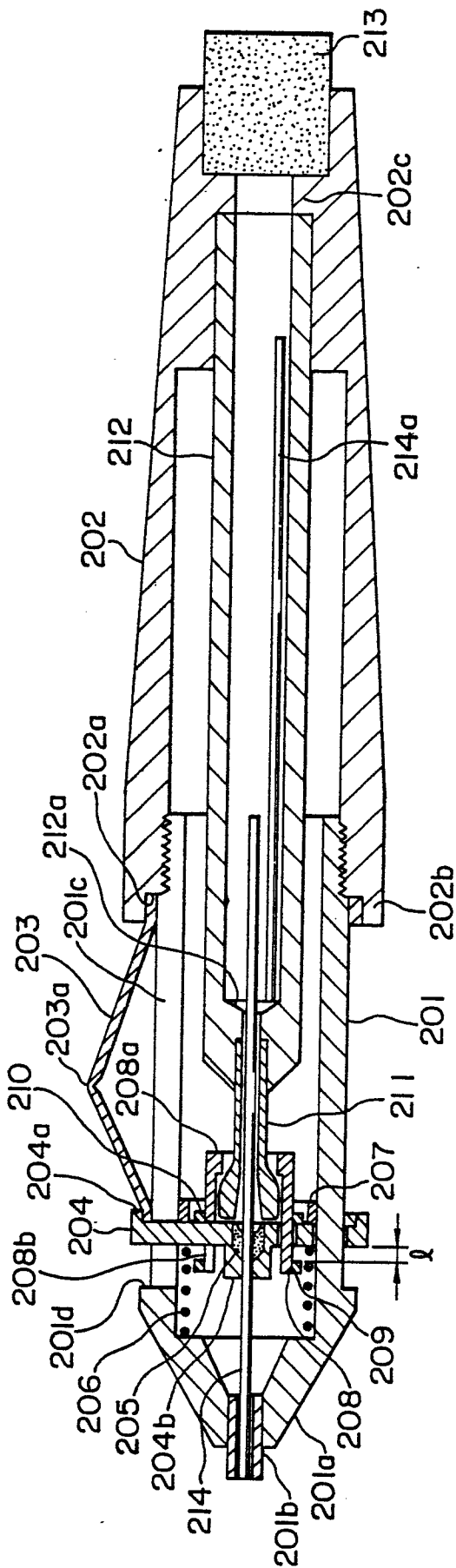
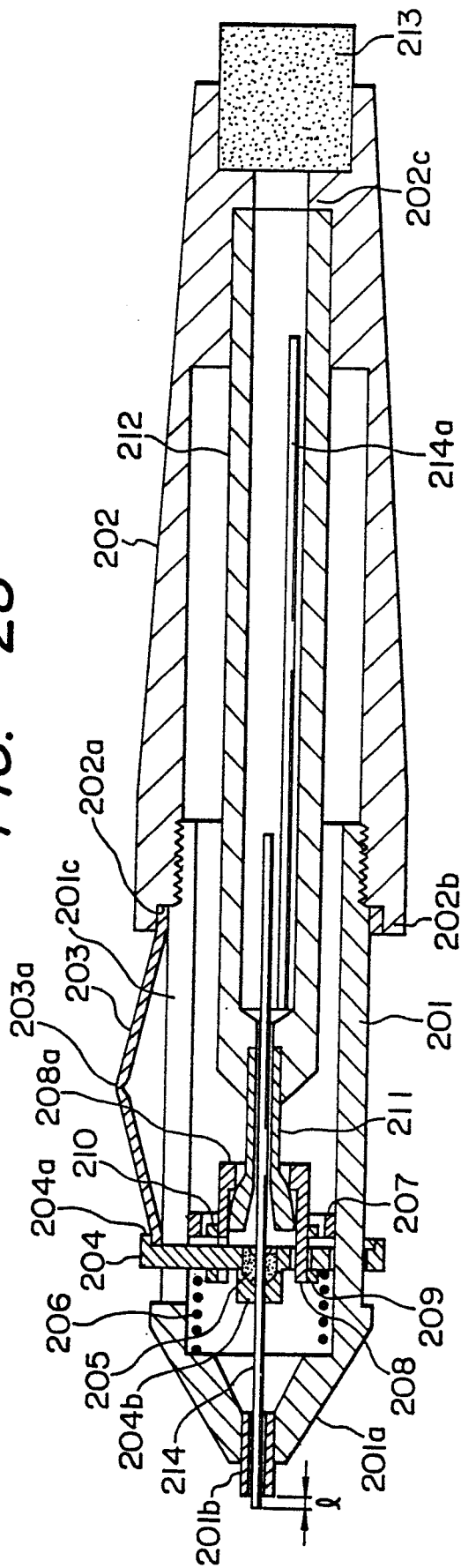

FIG. 28



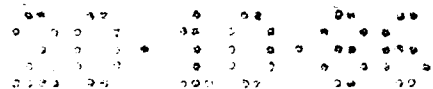

FIG. 31

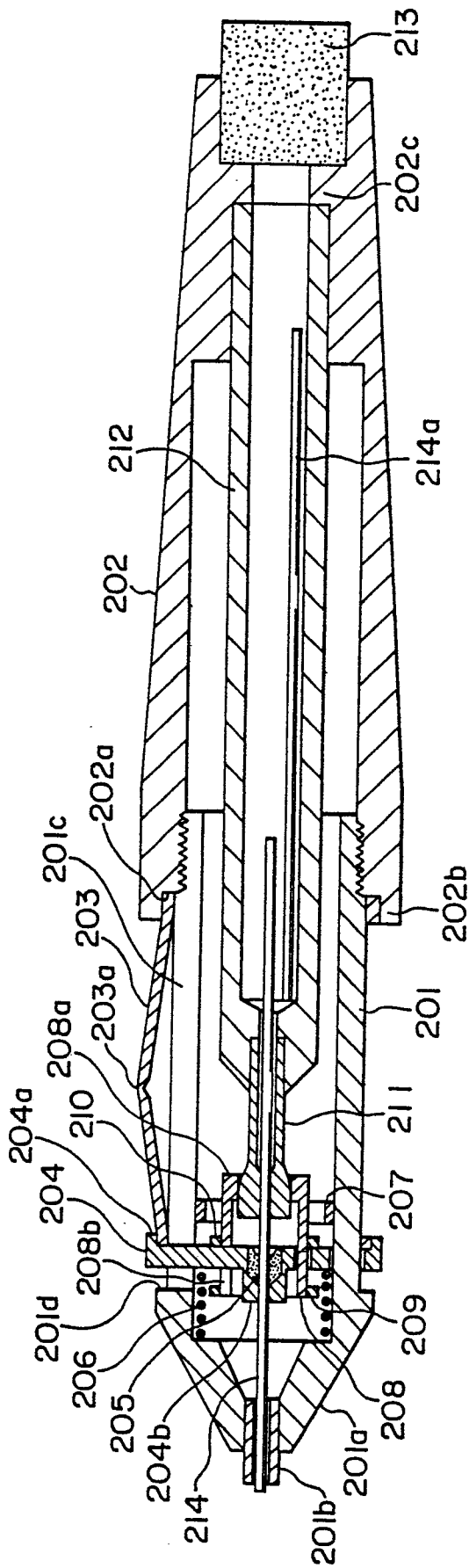
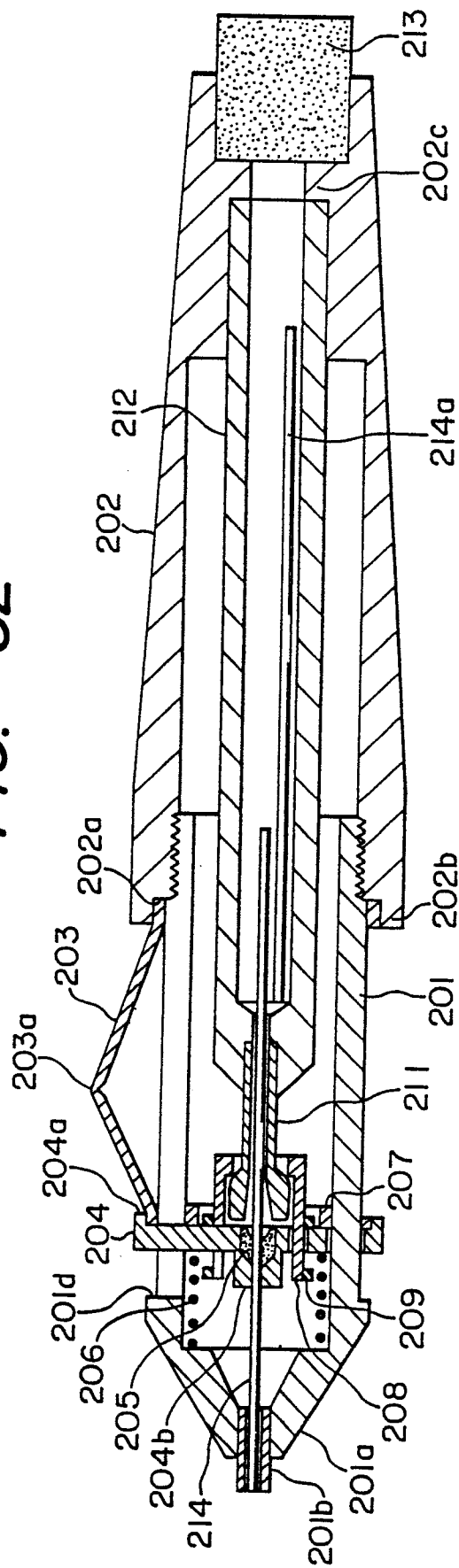

FIG. 32



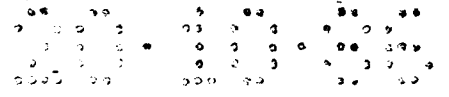

FIG. 33

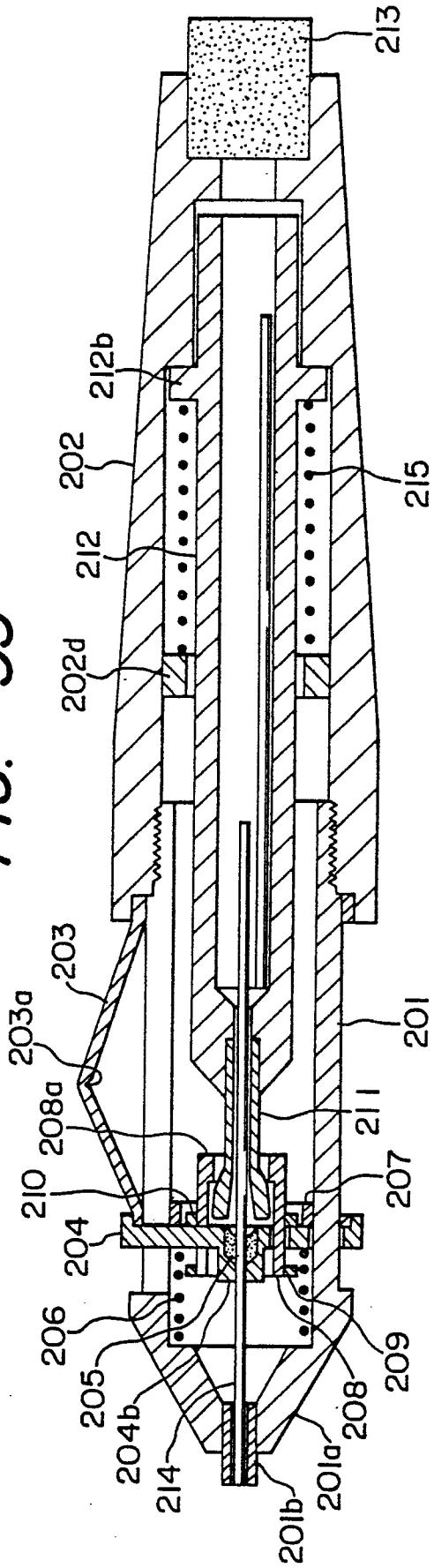
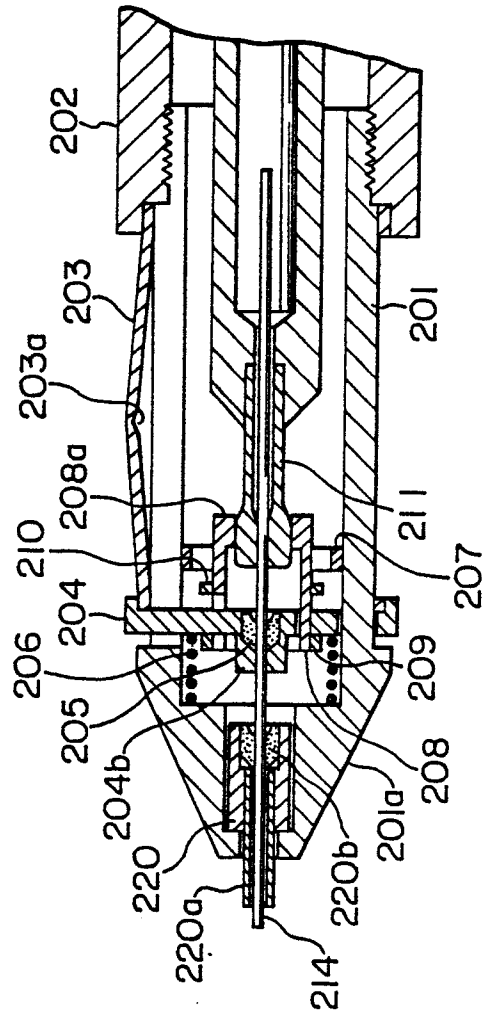

FIG. 34



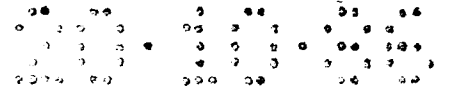

FIG. 35

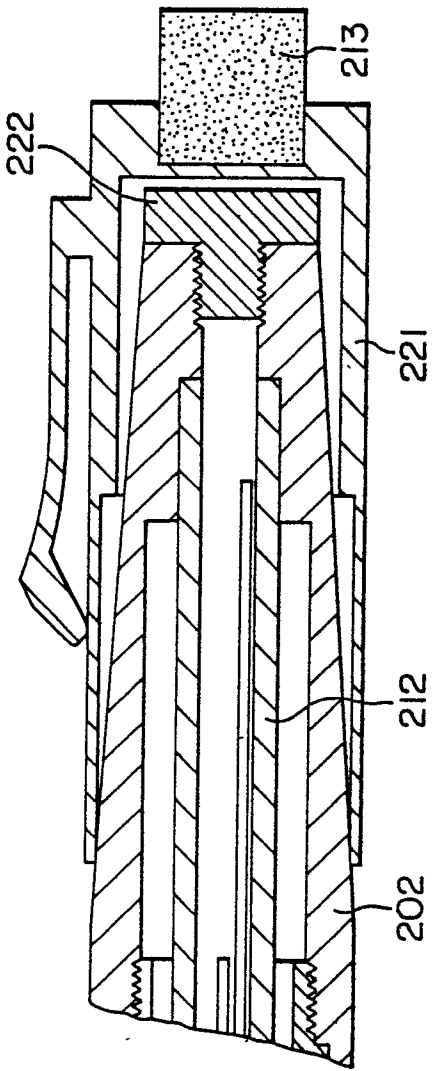
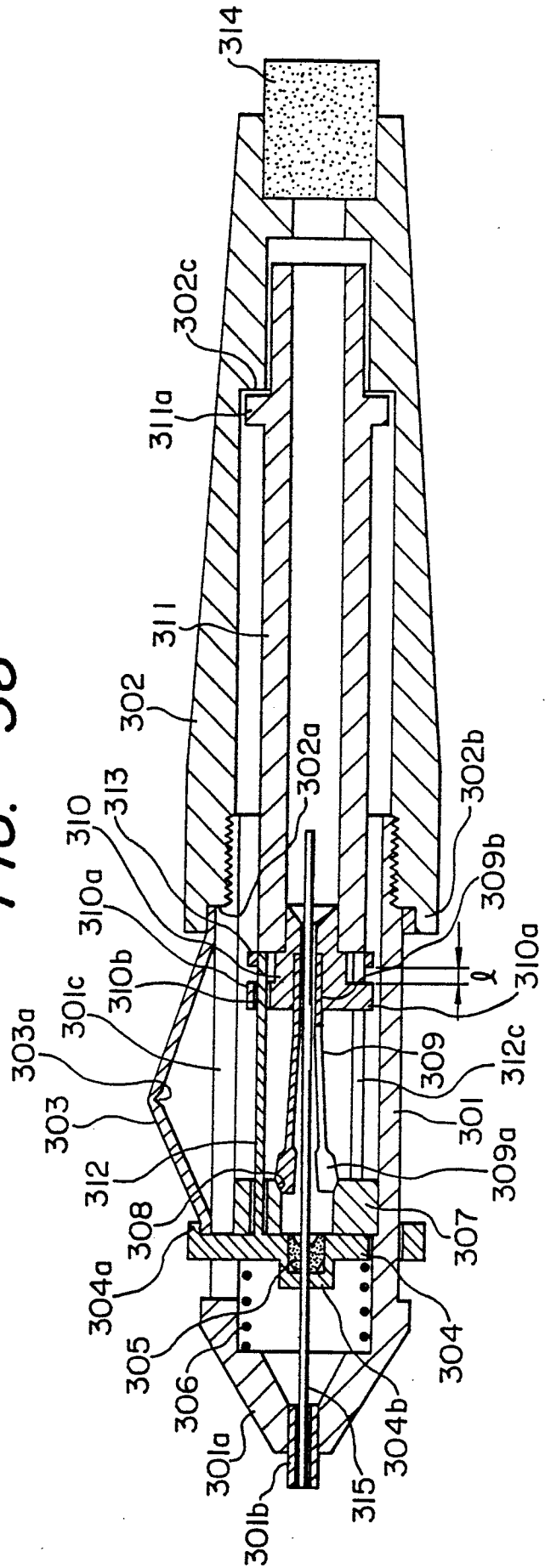

FIG. 36



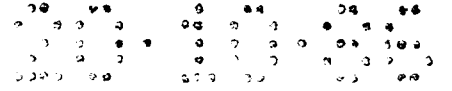

FIG. 37

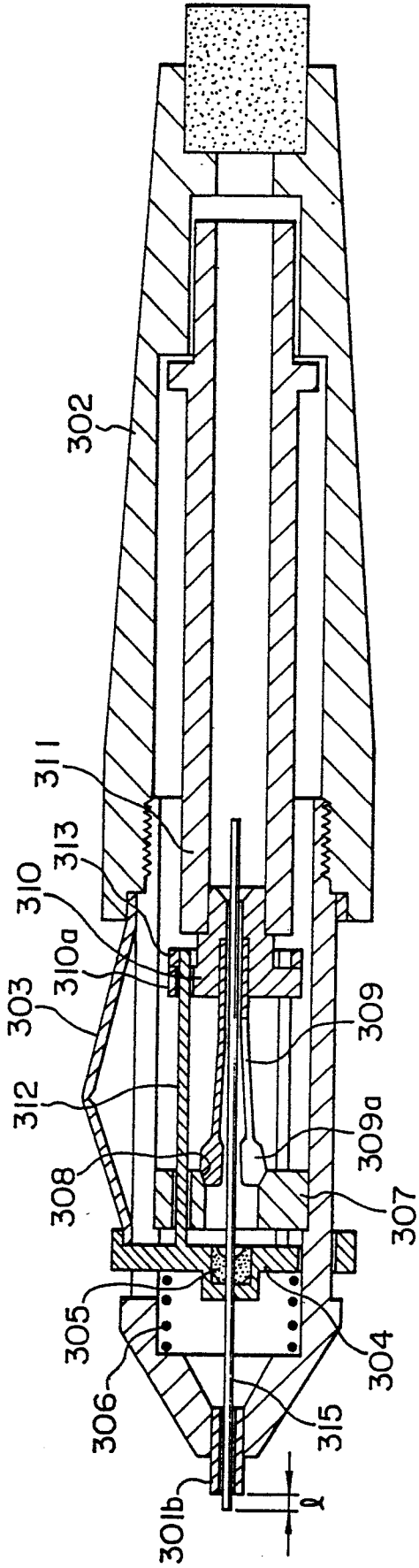
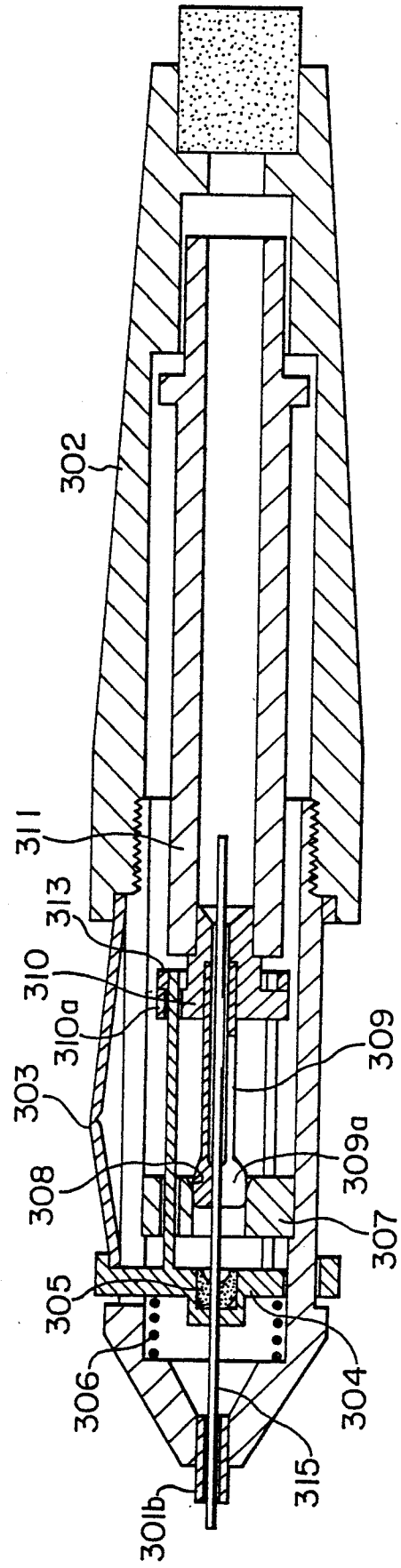

FIG. 38



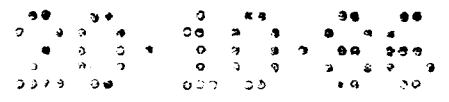
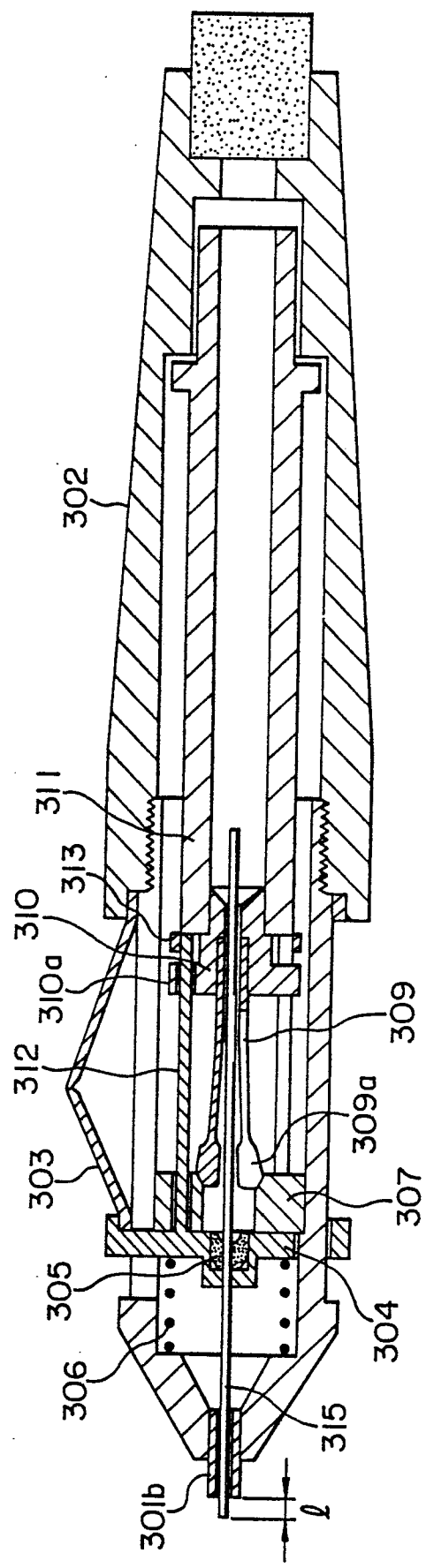

FIG. 39



FIG. 40



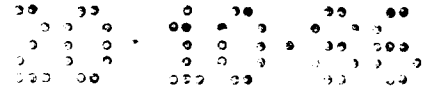
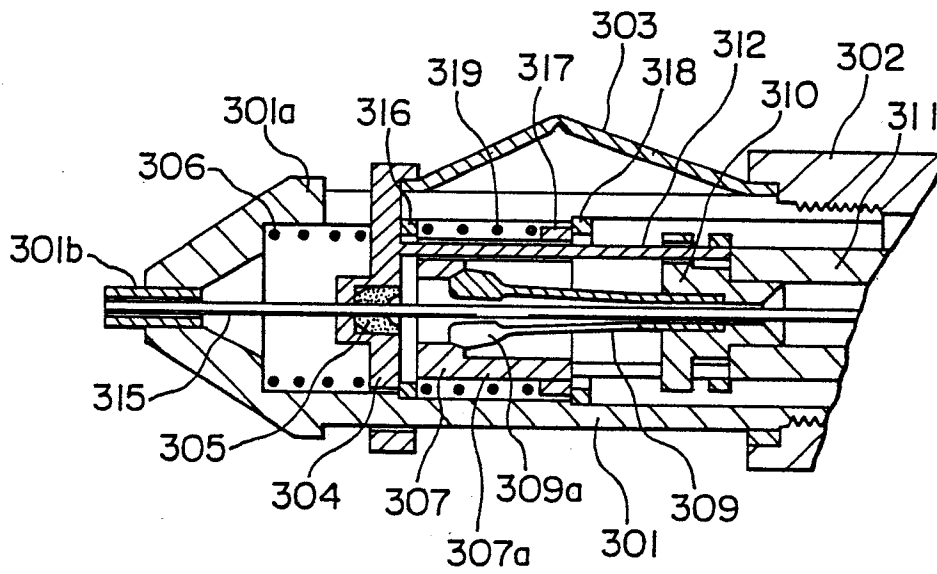

FIG. 41





DOCUMENTS CONSIDERED TO BE RELEVANT			
Category	Citation of document with indication, where appropriate, of relevant passages	Relevant to claim	CLASSIFICATION OF THE APPLICATION (Int. Cl.4)
D, X	DE-A-2 946 870 (ANCOS CO. LTD) * Page 25 - page 28, line 4 in particular page 27, lines 23-25; figures 17,21 *	1, 2, 4 8, 10, 11, 14 15, 20 24, 51	B 43 K 21/20
Y		18, 25	
A	* Pages 16-18 *	3, 35, 45	
D, Y	DE-A-2 821 625 (ANCOS CO. LTD) * Figures 5, 1 *	18, 25	TECHNICAL FIELDS SEARCHED (Int. Cl.4)
A	DE-A-2 921 875 (ANCOS CO. LTD)		B 43 K
The present search report has been drawn up for all claims			
Place of search THE HAGUE		Date of completion of the search 15-01-1987	Examiner VAN OORSCHOT J.W.M.
<p>CATEGORY OF CITED DOCUMENTS</p> <p>X : particularly relevant if taken alone Y : particularly relevant if combined with another document of the same category A : technological background O : non-written disclosure P : intermediate document</p> <p>T : theory or principle underlying the invention E : earlier patent document, but published on, or after the filing date D : document cited in the application L : document cited for other reasons & : member of the same patent family, corresponding document</p>			