



Europäisches Patentamt
European Patent Office
Office européen des brevets

Publication number:

**0 227 862
A1**

12

EUROPEAN PATENT APPLICATION

21 Application number: 85306299.0

51 Int. Cl.4: F24F 13/08

22 Date of filing: 05.09.85

43 Date of publication of application:
08.07.87 Bulletin 87/28

71 Applicant: **RACHELS INDUSTRIES INC.**
P O Box 76
Memphis Tennessee 38101(US)

64 Designated Contracting States:
AT BE CH DE FR GB IT LI LU NL SE

72 Inventor: **Dayus, Lloyd G.**
494 E. Racquet Club Place
Memphis Tennessee 33519(US)

74 Representative: **Hands, Horace Geoffrey et al**
GEORGE FUERY & CO Whitehall Chambers
23 Colmore Row
Birmingham B3 2BL(GB)

54 Frictional blade assembly.

57 A frictional blade assembly for grilles to be used in ventilation comprising a pair of thermoplastic support bars, (20,24) each bar having abutments (206,246) extending normal to one side, and having an outer surface of generally cylindrical shape diameter, formed integrally as part of the support bar, and having a plurality of blades (15), each being of uniform cross-sectional shape and size along its length, and defining a generally streamline-shaped tube, with a first edge, a second edge, and an internal space, the internal space at the first edge being of generally circular cross-section over an arc of approximately 270°, having a diameter of between 0.002" and 0.004" less than that of the abutments, the first end of the blades being rotatably attached to respective abutments at each end by inserting an abutment into the internal space at the first edge of the blade, making a frictional fit between each abutment and a respective blade.

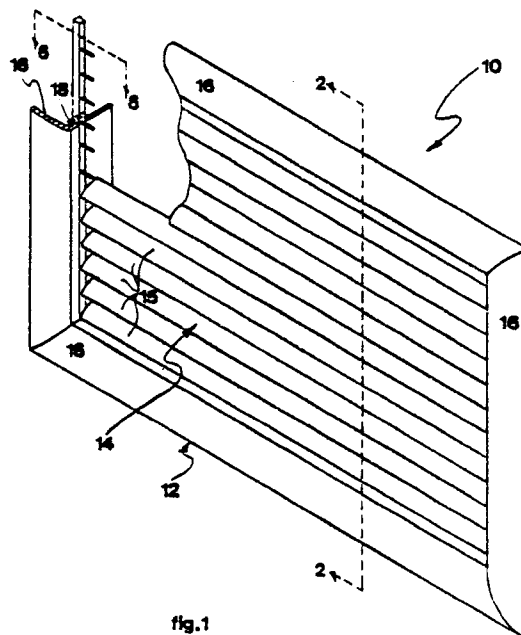

fig.1

Xerox Copy Centre

EP 0 227 862 A1

FRICTIONAL BLADE ASSEMBLY

The invention relates to a frictional blade assembly for a grille for use in ventilation systems.

Conventional grilles generally comprise a rectangular metal frame and a number of parallel transverse blades rotatably mounted to the frame. The blades are generally secured by friction in a particular angular position with respect to the frame and to the flow of air.

5 Several embodiments of such typical grilles are disclosed in United States Patent No. 4,103,601. However, conventional means for achieving a tight frictional fit between blade and the frame may suffer from one of two disadvantages. First, if the blade length is increased, for instance in the event that a wider air duct is used, the friction torques may be inadequate to resist the torque exerted on the blades by the pressure of the air moving in the duct. Second, a means for achieving an adequate frictional fit may be
10 expensive to manufacture and install.

It is therefore desirable to provide a frictional blade assembly for a grille in which the means for achieving a tight frictional fit is simple and inexpensive both to manufacture and to install.

This invention is a frictional blade assembly for grilles to be used in association with ventilation systems wherein said assembly comprises, a pair of thermoplastic support bars in spaced parallel relation each
15 having a plurality of coplanar abutments extending normal to one side of said bars directed in registration with each other, each of said abutments having an outer surface of uniform shape with a generally cylindrical outline, said abutments being formed integrally as part of said support bar, a plurality of blades located between said bars, each of said blades defining first and second ends and being of uniform cross-sectional shape and size along its length, each said blade defining a generally streamline-shaped tube, said
20 tube defining a first edge, a second edge and an internal space, said internal space at said first edge being of generally circular cross-section over an arc of approximately 270°, said circular cross-section having a diameter of between 0.002" and 0.004" less than that of said abutments, said blades being rotatably attached to respective said abutments at opposite ends by inserting a said abutment into said internal space at the first edge of a said blade, whereby a frictional fit between each said abutment and a respective
25 said blade is obtained.

It is an objective of the invention to provide means for achieving a frictional fit between the blades and the framework of an air grille and which is of reduced diameter to minimize blade thickness and maximize open area for air flow.

It is a further objective of the invention to provide for a frictional blade assembly that is inexpensive and
30 simple to manufacture and install.

The invention is now described and illustrated in preferred embodiments.

IN THE DRAWINGS

35 Figure 1 is a partially cut away perspective view of one embodiment of the invention as it may be used in a complete grille assembly;
Figure 2 is a cross-section along the line 2-2 of Figure 1;
Figure 3 is an exploded view of a partial frictional blade assembly according to the invention;
40 Figure 4 is a cross-section of one embodiment of an air deflector blade;
Figure 5 is a close-up view, in perspective, of the insertion of a supporting abutment into an air deflector blade in one embodiment of the invention;
Figure 6 is a section along line 6-6 of Figure 1;
Figure 7 is a section along line 7-7 of Figure 6;
45 Figure 8 is a cross-sectional view similar to that shown in Figure 7 of an alternate embodiment;
Figure 9 is a plan view of an alternate embodiment of the invention;
Figure 10 is a cross-section along the line 9-9 of Figure 9, and
Figure 11 is a section of another embodiment.

50

DESCRIPTION OF A SPECIFIC EMBODIMENT

Referring now to Figures 1 and 2, there is illustrated a typical grille assembly 10, comprising a rectangularly-shaped grille frame 12 within which is supported frictional blade assembly 14. Grille frame 12 may comprise typical frame members 16, such as are illustrated in Figures 1 to 5 of United States Patent No. 4,103,601, held together at its corners in any conventional fashion. Frame members 16 may define a recess 18 within which blade assembly 14 may be supported. Such a recess 18 is preferably trapezoidal in cross-sectional shape, although other shapes may be acceptable. Blade assembly 14 includes a plurality of rotatable, transverse, parallel air deflector blades 15. The angular position of each such blade 15 in operation is fixed with respect to frame members 16. Such angular position may be altered manually or otherwise. The direction of flow of air is changed by blades 15 from the direction indicated by arrow A at the entrance to grille assembly 10 to the direction indicated by arrow B at the exit of grille assembly 10. The angle through which air is deflected is typically less than 20°.

Referring to Figure 3, frictional blade assembly 14 includes a first and second thermoplastic support bars 20 and 24. First support bar 20 defines a stem 20a which defines a longitudinal axis L. Support bar 20 further defines a plurality of coplanar abutments 20b, extending essentially normal to one side of axis L, and formed integrally with stem 20a. Each of abutments 20b defines an outer surface of uniform shape of generally cylindrical outline (see Figures 6 and 7). Each of abutments 20b is of more or less the same length and diameter as all other abutments 20b. Each abutment 20b defines a tapered free end 20c. Free end 20c may conveniently be of frusto-conical shape, but other shapes may be acceptable. Support bar 20 may further define longitudinal stem extensions 20d, which may be used to assist in positioning frictional blade assembly 14 within grille frame 12. Bar 20 may define a surface 20f at which abutments 20b join stem 20a.

In a further embodiment, an abutment 20b may define channel means 20e extending along the surface of abutment 20b (see Figure 8). Such channel means 20e may offer advantages in the event that blades 15 or blade assembly 14 are cleaned, painted or otherwise treated. During operations of this nature, fluid may be trapped within blades 15. If the blade assembly 14 is later subjected to heat, such fluids may be vaporized and pressurized. The pressurization may cause damage to the blade assembly 14. The provision of channel means 20e allows fluid and vapour to escape the interior of blades 15 without causing any damage.

Stem 20a and extensions 20d may conveniently have a trapezoidal cross-section adapted to dovetail into recess 18 of frame member 16 (see Figure 6). Other shapes adapted to fit within recess 18 may be acceptable. Stem 20a may have sufficient depth so that surface 20f is raised above recess 18. Such a configuration conveniently allows surface 20f to act as a bearing surface keeping the end of a blade 15 out of contact with frame members 16. Also, in the event that the blade assembly 14 is cleaned, painted or otherwise treated, fluid may escape without restriction by frame members 16.

The second ends of blades 15 are rotatably attached to a second thermoplastic support bar 24. Second support bar 24 may be essentially identical to first support bar 20. Second support bar 24 defines abutments 24b and stem extensions 24d. Abutments 24b are inserted into portion 22a of space 22 at the second end of each of blades 15.

A plurality of blades 15 are rotatably attached between thermoplastic support bars 20 and 24. Each of blades 15 defines a first end and a second end and is of uniform cross-sectional shape and size along its length. Each blade 15 is formed to define a generally streamline-shaped tube. Each such blade may be generally planar in shape or may be curved, or may be of any shape that is generally known in the art. Each blade 15 defines a first edge 15a, a second edge 15b, and an internal space 22. The internal surface of first edge 15a defines a portion 22a of space 22, said portion 22a being of generally circular cross-section over an arc of approximately 270°. The circular cross-section preferably has a diameter of between 0.002" and 0.004" less than that of abutments 20b. A blade 15 may define at least one external surface groove 23a (see Figure 4) along its length. Such external grooves 23a form internal ridges 23b. Such groove 23a and ridge 23b formations provide blade 15 with additional stiffness and strength.

Blades 15 are rotatably attached to abutments 20b-24b by inserting the abutments into portion 22a of space 22 at a same one end of blades 15. The relative diameter of portion 22a and of abutment and a 270° arc of portion 22a ensures that first edge 15a acts like a spring clamped around and radially squeezing against the abutment. Figure 5 illustrates a close up view of an end of blade 15 about to be fitted over abutment. The figure in phantom indicates the position of blade 15 when abutment is fully inserted into blade 15. The blades 15 are mounted and adjusted so that each blade 15 defines the desired angle with respect to stem through which angle air is to be deflected.

The width of a blade 15, that is, the distance between the first edge 15a and the second edge 15b, corresponds approximately to the distance between abutments. Such width may conveniently be within the range 0.490" to 1.010". Conceivably, blades 15 may be rotated to a more or less vertical position to essentially close the grille assembly 10 although this would be most unusual. In order that the frictional torque applied to blades 15 is sufficient to resist the torques generated by air pressure at this extreme position, the diameter of abutments is preferably between 0.002" and 0.004" greater than that of portion 22a of space 22. If more extreme conditions must be met or if blades having a width greater than 1.0" are used, additional frictional forces may be generated by decreasing the diameter of portion 22a or by increasing the diameter of the abutments. The width of blades 15 for use in association with the abutments of a particular diameter is limited by the fact that blades 15 must be able to maintain a sufficient spring-like clamping action against the abutments.

The diameter of abutments is limited both by the thickness of the material used in blades 15 and by the amount of free area required to allow air to flow through the grille 10. The maximum free area for air to flow through a grille 10 is available when blades 15 are oriented parallel to the flow of air entering the grille 10. With the blades 15 in such an angular position, air is not deflected by the blades 15 and there is no change in direction of air flow. When the blades 15 are angled with respect to frame 16, there is less area in the grille 10 available for the flow of air. It is possible that the flow of air may be restricted below a pre-determined acceptable level.

If the diameter of the abutments is too great the blades will be too thick. In this case, even when blades 15 are parallel to the air flow, there may be an insufficient flow of air through grille 10 due to the thickness of the blades. Consequently, the abutments must have a small enough diameter to permit the use of thinner blades and thus allow a satisfactory air flow through grille 10 even at the desired angular orientation of blades 15.

The area available for the flow of air through the grille 10 is further reduced by the thickness of the material used to form blades 15. The thickness of such material must be sufficient to allow blades 15 to be conveniently manufactured and to satisfactorily clamp around the abutments. Consequently, the combination of abutment diameter and material thickness must define a total blade thickness that will allow a satisfactory air flow through grille 10 at the desired angular orientation of blades 15.

The diameters of the abutments and the blade material thickness are preferably related to the amount of area of the grille 10 by the following relationship:

$$0.15 \leq \lambda \frac{(d + 2t)(n + 1)}{A} \leq 0.4$$

35

where (λ = blade length

(d = the diameter of abutment

(t = blade material thickness

40

(A = grille area

(n = number of blades

When a longer blade is used, more air pressure torque is applied to the blade. The longer an abutment is, the more frictional torque can be generated. Thus, in order to counter the air pressure torque, longer abutments may be used. Preferably, blade lengths are less than or equal to 24" and the abutments are less than or equal to 1.0" in length exclusive of the length of the frusto-conical end.

The blades 15 are thus supported between and by support bars 20 and 24. The friction between a blade 15 and its associated abutments 20b and 24b is sufficient to prevent blade 15 from rotating from its predetermined desired angular position with respect to frame 16. Yet, such friction is not so great as to prevent such angular position from being manually, or otherwise, adjusted or changed, if desired. Nor is such friction so great as to interfere with the ease of assembly of the frictional blade assembly 14.

In operation, frictional blade assembly 14 is inserted into grille frame 12. This is accomplished by sliding support bars 20 and 24 into recesses 18 in frame members 16. The grille assembly is then installed in the desired duct or opening. The angular orientation of blades 15 to grille 10 may be manually adjusted to the desired position. The frictional blade assembly 14 will then operate to deflect the flow of air as directed.

Several factors contribute to the success of the invention. First, the materials of the invention and surface finishes of such materials may be selected and prepared to provide suitable frictional resistances to air pressure torques. Thermoplastic polyester (for the support bars 20 and 24) and roll-formed aluminum sheet metal (for the blades 15), both with smooth surface finishes, have a satisfactory coefficient of static friction relative to each other and have been found to be suitable materials to provide acceptable frictional resistance. Preferably, such thermoplastic polyester has between 20% and 30% glass fibre content for added durability and strength. Materials such as POCAN B #4225 or #4235 (trade mark) may be acceptable materials. POCAN B #4255 or #4235 has a coefficient of static friction relative to lapped steel plate of between 0.11 and 0.13. Aluminum has a coefficient of static friction relative to mild steel of between 0.5 and 0.7. Both thermoplastic polyester and aluminum are inexpensive, strong, tough, durable, corrosion-resistant, and light-weight, and thus the frictional blade assembly according to the invention has similar properties and is easy to assembly and install. Other blade materials such as sheet steel, plastic or nylon may be acceptable.

Second, the form of abutments 20b and 24b and the cylindrical form portion 22a of internal space 22 provides a maximum amount of surface area over which frictional forces may be developed. Third, the relative diameters of abutments 20b and 24b and of portion 22a of space 22 (the diameter of abutments 20b being preferably between 0.002" and 0.004" greater than that of portion 22a) are important to provide satisfactory frictional forces and yet maintain ease of assembly and long life. Fourth, the arc of circular portion 22a extending over about 270° is also important to allow first edge 15a of blade 15 to act in a spring-like fashion against abutments 20b and 24b. This provides satisfactory radial forces and corresponding frictional forces between the abutments and the internal surfaces of first edges 15a. Fifth, the relationship between the diameter of abutments 20b and the width of blades 15 is important to adjust the required frictional forces when different distances between abutments are used and to maintain a suitable grille maximum free area. Sixth, the relationship between abutment length and blade length may be used to adjust the required frictional forces when different blade lengths are used. Seventh, the relationship between abutment diameter to material thickness of blades 15 is important to adjust the strength of the spring-like action of blades 15 against abutments 20b and 24b. Eighth, the ratio of grille maximum free area to the total grille area is important to ensure a satisfactory flow of air through grille 10 when blades 15 are positioned at the desired angular orientation.

Referring to Figures 9 and 10, in a further embodiment, the angular position of blades 15 with respect to frame 12 may be permanently fixed. Such an embodiment may be conveniently used in a return air grille.

The first edge 15a of blades 15 are affixed, as in the embodiment described above and illustrated in Figures 1 to 8, to first and second thermoplastic support bars 20 and 24. In the embodiment of Figures 9 and 10, the second edge 15b of blades 15 is affixed to third and fourth thermoplastic support bars 26 and 28 respectively, which may conveniently be essentially identical to support bars 20 and 24. Bars 26 and 28 define stems, stem extensions, and abutments, similar to those of bars 20 and 24.

The internal surface of the second edge 15b of each blade 15 defines a portion 22b of internal space 22, said portion being of generally circular cross-section over an arc of about 270°. As in the case of the first edge 15a, said circular cross-section may conveniently have a diameter of between 0.002" and 0.004" less than that of the abutments of support bars 26 and 28. The abutments of bars 26 and 28 are inserted into portion 22b. Such a relationship between the diameters of portion 22b and the abutments of bars 26 and 28 ensures that the second edge 15b will not vibrate against the abutments and allows for the use of standard parts. All support bars 20, 24, 26 and 28 may conveniently be essentially identical. Thus, manufacturing costs are less than would be the case if the first edge support bars 20 and 24 were different from second edge support bars 26 and 28. However, bars 26 and 28 do not necessarily have to be identical in every respect to bars 20 and 24. It is sufficient if bars 26 and 28 have a shape similar to that of bars 20 and 24 and if bars 26 and 28 are dimensioned to be insertable into said portions 22b of internal space 22, whereby to prevent rotation of blades 15 about the abutments of bars 20 and 24.

Frame members 16 define a second recess 30 within which bars 26 and 28 may be supported. As in the case of recess 18, recess 30 is preferably trapezoidal in cross-sectional shape in order to dovetail with the stems of bars 26 and 28.

The abutments of bars 26 and 28 may be vertically offset from abutments 20b and 24b, respectively, in order to define the specific angle at which blades 15 are to be oriented. Stem extensions on bars 26 and 28 may have to be truncated or cut off, depending on the chosen blade angle.

In a further embodiment, it may be possible to utilize a second support bar 24, defining abutments which act only as pivots for blades 15. In such an embodiment, the first bar 20 is sufficient to retain blades 15 in the desired angular position. Second bar 24 does not assist in preventing rotation of blades 15.

All the above factors permit the manufacture of specific sizes and capacities of grilles to suit many requirements. Yet, the qualities of low cost, durability and simplicity of manufacture and installation are maintained. Thus, the frictional blade assemblies may be manufactured as and when ordered and required. Inventory may therefore be conveniently stored as stacking blades and frame members in standard lengths.

5 The blades are economically formed from strip sheet aluminum by roll forming. Lengths of hollow roll formed blades are saw cut as desired to provide blades having straightcut ends. The use of blades having straight ends in a blade assembly according to the invention avoids the difficult and costly cutting and notching operations on hollow roll-formed blade stock. Furthermore, cutting of blades and assembly of blade assemblies and grilles may be automated to reduce the amount of hand labour. Such automated

10 assembly procedures may increase the speed of manufacture, thus yielding a faster response to orders.

A further embodiment of a blade section is shown in Figure 11. It defines a blade 30 having a semi-cylindrical portion 32, and two spaced apart side members 34-34 extending therefrom. Median rib portions 36-36 are squeezed together, in side portions 34, and the free edge 38 of one side wall is folded over the other.

15 The foregoing is a description of a preferred embodiment of the invention which is given here by way of example only. The invention is not to be taken as limited to any of the specific features as described, but comprehends all such variations thereof as come within the scope of the appended claims.

20 Claims

1. A frictional blade assembly for grilles to be used in association with air ventilation systems wherein said assembly comprises:
first and second thermoplastic support bars each defining a stem, which stem defines a longitudinal axis,
25 and having a plurality of coplanar abutments extending essentially normal to one side of said axis, each of said abutments being more or less the same length and having an outer surface of uniform generally cylindrical shape and having more or less the same diameter, and said abutments being formed integrally as part of said support bars, said support bars being located in spaced parallel relation with said abutments directed towards one another;
30 a plurality of blades located between said bars, each of said blades defining a first and second ends and upper and lower sides, and being of uniform cross-sectional shape and size along its length, each said blade defining a generally streamline-shaped tube, said tube defining a first edge, a second edge and an internal space, the tube being formed from an integral sheet of relatively thin material whereby the sheet is bent back upon itself and one sheet edge is secured below another, said internal space at said first edge
35 being of generally circular cross-section over an arc of approximately 270°, said circular cross-section having a diameter of between 0.002" and 0.004" less than that of said abutments, said first end of said blades being rotatably attached to respective said abutments by inserting a said abutment into said internal space at the first edge of said blade, whereby a frictional fit between each said abutment and a respective said blade is obtained, whereby said blades may be rotated relative to said first and second bars against a
40 frictional resistance, and,
longitudinal rib means formed along the length of each side of each blade, in opposition to each other.
2. A frictional blade assembly as claimed in Claim 1 wherein said second thermoplastic support bar is essentially identical to said first support bar.
3. A frictional blade assembly as claimed in claim 2 wherein said blades have a width greater than
45 0.490" and less than 1.010".
4. A frictional blade assembly as claimed in Claim 3 wherein each said abutment defines a tapered free end.
5. A frictional blade assembly as claimed in Claim 4 wherein said blades are less than or equal to 24" in length and said abutments are less than or equal to 1.0" in length, said abutment length being exclusive
50 of the length of said tapered free end of said abutment.
6. A frictional blade assembly as claimed in Claim 5 wherein said stems of said thermoplastic support bars define stem extension portions extending along said axis from said stems.
7. A frictional blade assembly as claimed in Claim 6 wherein said thermoplastic is a thermoplastic polyester containing 20% to 30% glass fibres.
8. A frictional blade assembly as claimed in Claim 7 wherein said blades are roll-formed from sheet
55 aluminum.
9. A frictional blade assembly as claimed in Claim 8 wherein the diameters of said abutments and the said aluminum thickness are related to the amount of total grille area by the following relationship:

$$0.15 \leq \frac{\ell (d + 2t) (n + 1)}{A} \leq 0.4$$

5

where (ℓ = blade length

(d = the diameter of abutment 20b

(t = blade material thickness

10

(A = grille area

(n = number of blades

15 10. A blade as claimed in Claim 1 wherein said rib means comprises at least one external groove and internal ridge formation extending along the length of the blade on each side thereof, the said formations on each side defining a space therebetween.

11. A frictional blade assembly as claimed in Claim 2 wherein said surface of each of said abutments defines groove means extending along said surface.

20 12. A frictional blade assembly as claimed in Claim 6 wherein said stem extrusions define a trapezoidal cross-section.

13. A frictional blade assembly as claimed in Claim 4 wherein said tapered free end defines a frusto-conical shape.

25 14. A frictional blade assembly as claimed in Claim 1 wherein said internal space at said second edge of said blades is of generally circular cross-section over an arc of approximately 270° and including third and fourth thermoplastic support bars, each of said third and fourth bars defining a stem, which stem defines a longitudinal axis, and having a plurality of coplanar abutments extending essentially normal to one side of said axis, each said abutment of said third bar being inserted into said internal space at the second edge of a respective said blade at said first end of said blade, each said abutment of said fourth bar being inserted into said internal space at the second edge of a respective said blade at said second end of said blade.

30 15. A frictional blade assembly as claimed in Claim 14 wherein each of said abutments of said third and fourth bars defines a circular cross-section and has a diameter of between 0.002" and 0.004" greater than that of said circular cross-sectional portion of said internal space at said second edge of said blades.

35 16. A frictional blade assembly as claimed in Claim 15 wherein said second, third, and fourth bars are essentially identical to said first bar.

17. A grille assembly for use in association with air ventilation systems wherein said assembly comprises:

a frictional blade assembly, and,

40 a grille frame means in which said blade assembly is supported;

wherein said blade assembly comprises:

45 first and second thermoplastic support bars each defining a stem, which stem defines a longitudinal axis, and having a plurality of coplanar abutments extending essentially normal to one side of said axis, each of said abutments being more or less the same length and having a smooth outer surface of uniform cylindrical shape and having more or less the same diameter and defining a tapered free end, said abutments being formed integrally as part of said support bar, said support bar being located in spaced parallel relation with said abutments directed towards one another;

50 a plurality of blades located between said bars, each of said blades defining a first and second ends and upper and lower sides, and being of uniform cross-sectional shape and size along its length, each said blade defining a generally streamline-shaped tube, said tube defining a first edge, a second edge and an internal space, the tube being formed from an integral sheet of relatively thin material whereby the sheet is bent back upon itself and one sheet edge is secured below another, said internal space at said first edge being of generally circular cross-section over an arc of approximately 270°, said circular cross-section having a diameter of between 0.002" and 0.004" less than that of said abutments, and said first end of said blades being rotatably attached to respective said abutments by inserting a said abutment into said internal space at the first edge of said blade, whereby a frictional fit between each said abutment and a respective

55

said blade is obtained, whereby said blades may be rotated relative to said first and second bars against a frictional resistance, and,

longitudinal rib means formed along the length of each side of each blade, in opposition to each other.

5 18. A grille assembly as claimed in Claim 17 wherein said second thermoplastic support bar is essentially identical to said first support bar.

19. A grille assembly as claimed in Claim 18 wherein said frame means defines a first recess, said recess being adaptable to receive and support said frictional blade assembly.

20. A grille assembly as claimed in Claim 19 wherein said stems and said first recess define trapezoidal cross-sections whereby said support bars may be dovetailed into said first recess.

10 21. A grille assembly as claimed in Claim 20 wherein said stem extends outwardly of said recess whereby to define a clearance between said blades and said grille frame means.

22. A grille assembly as claimed in Claim 17 wherein said internal space at said second edge of said blades is of generally circular cross-section over an arc of approximately 270° and including third and fourth thermoplastic support bars each of said third and fourth bars defining a stem, which stem defines a longitudinal axis, and having a plurality of coplanar abutments extending essentially normal to one side of said axis, each said abutment of said third bar being inserted into said internal space at the second edge of a respective said blade at said first end of said blade, each said abutment of said fourth bar being inserted into said internal space at the second edge of a respective said blade at said second end of said blade.

23. A grille assembly as claimed in Claim 22 wherein said frame means defines first and second recesses, said first recess being adaptable to receive and support said first and second support bars and said second recess being adaptable to receive and support said third and fourth support bars.

24. A grille assembly as claimed in Claim 23 wherein said second, third and fourth support bars are essentially identical to said first support bar and wherein said stems and said first and second recesses define trapezoidal cross-sections whereby said support bars may be dovetailed into said first and second recesses.

25. A blade for use in an air ventilation grille, said grille including thermoplastic support bars having a plurality of coplanar abutments of cylindrical shape, said blade defining a first and second end, and being of uniform cross-sectional shape and size along its length, each said blade defining a generally streamline-shaped tube, said tube defining a first edge, a second edge and an internal space, the tube being formed from an integral sheet of relatively thin material whereby the sheet is bent back on itself and one sheet edge is secured below another, said internal space at said first edge being of generally circular cross-section over an arc of approximately 270°, said circular cross-section having a diameter of between 0.002" and 0.004" less than that of said abutments, said first end of said blades being adaptable to be rotatably attached to a said abutment by inserting said abutment into said internal space at the first edge of the blade, whereby a frictional fit between the abutment and the blade is obtained, and, longitudinal rib means formed along the length of each side of each blade, in opposition to each other.

40

45

50

55

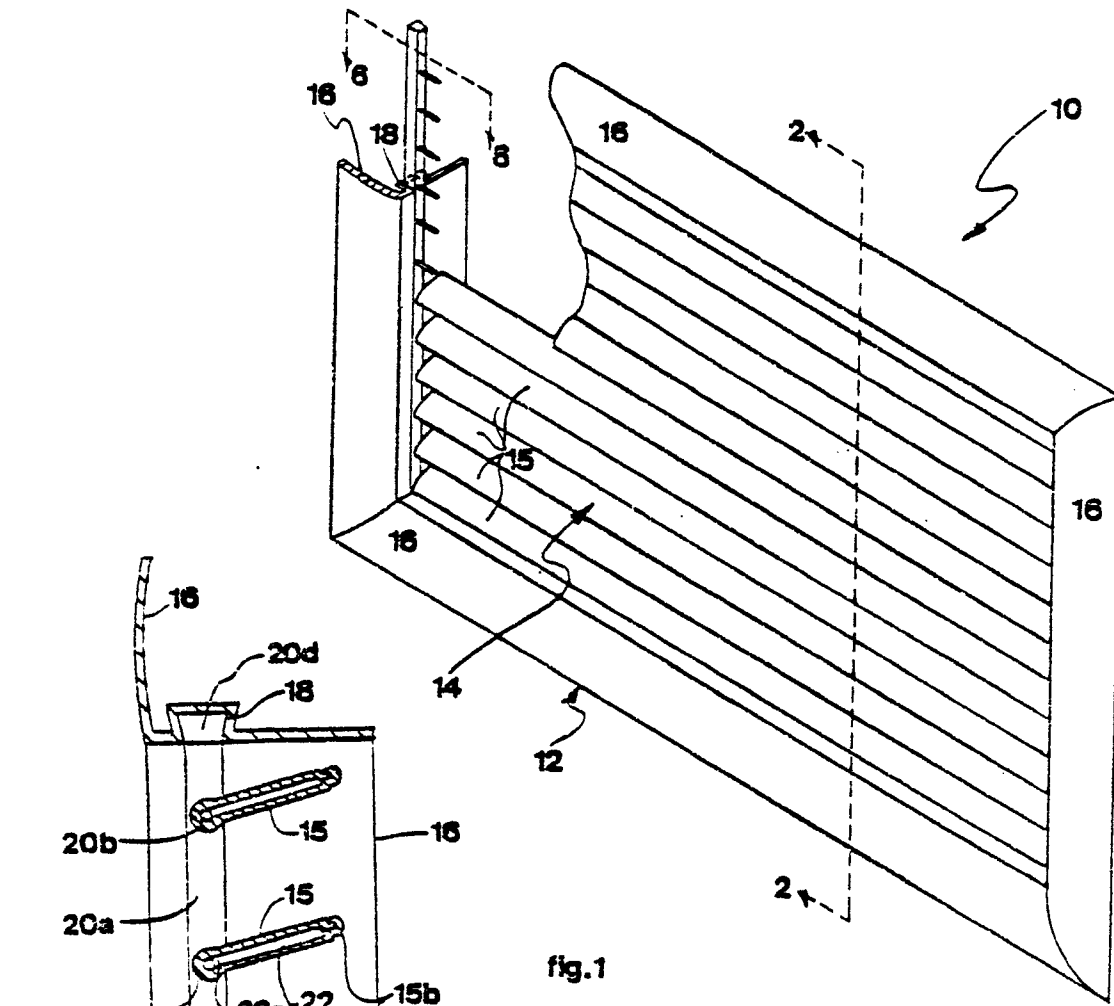

fig.1

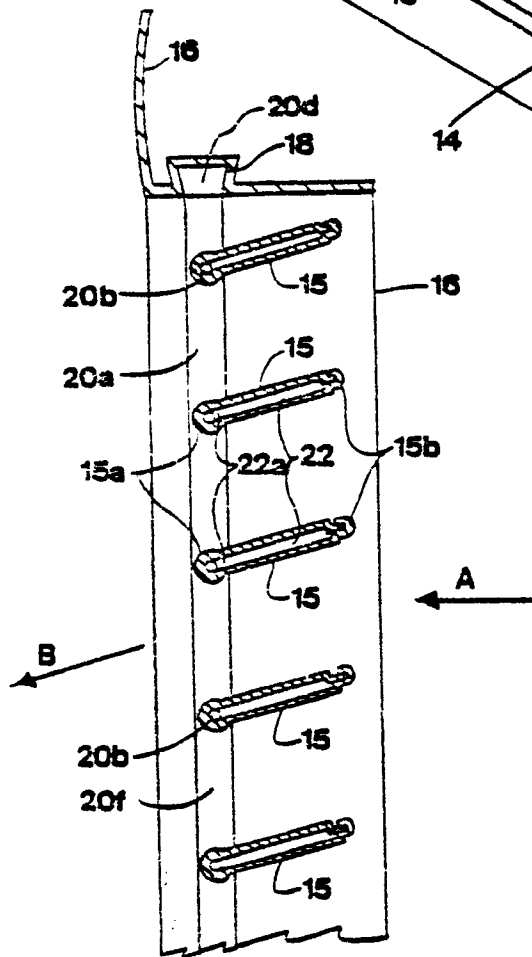

fig.2

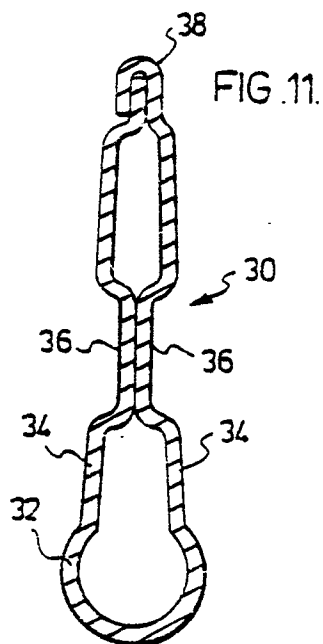

FIG. 11.

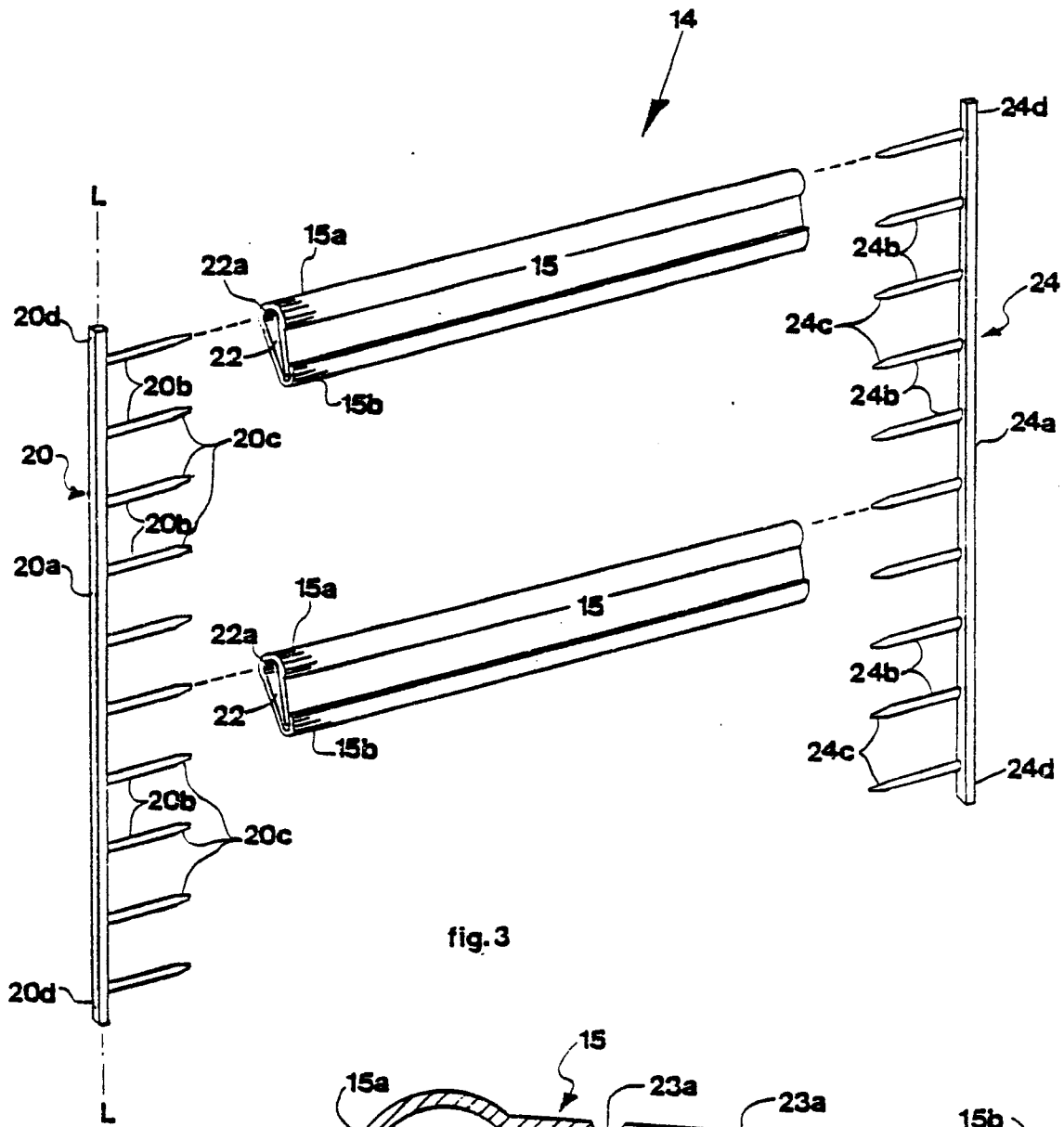

fig.3

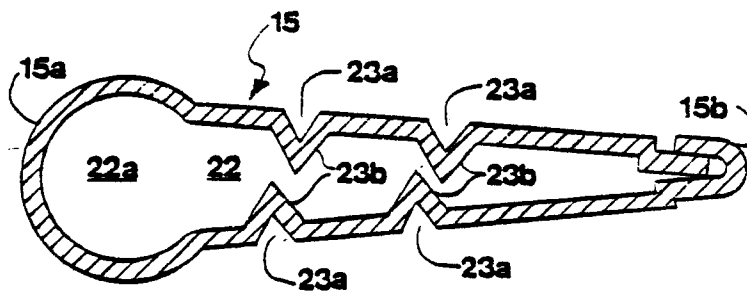

fig.4

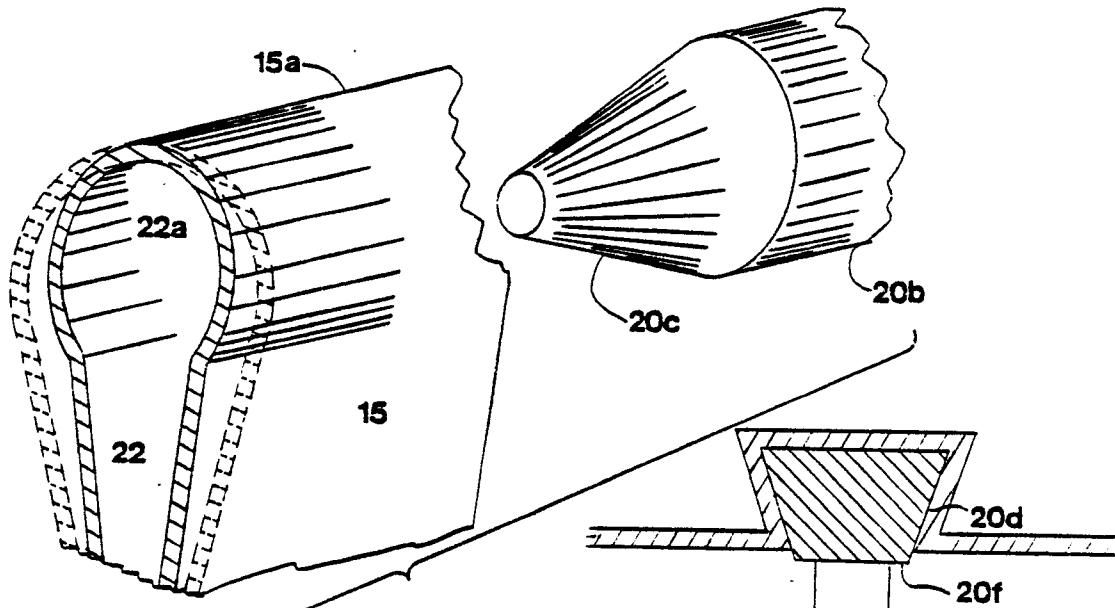

fig.5

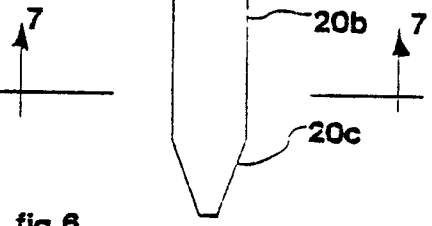

fig.6

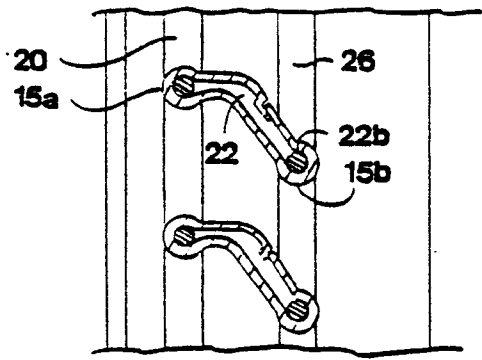

fig.10

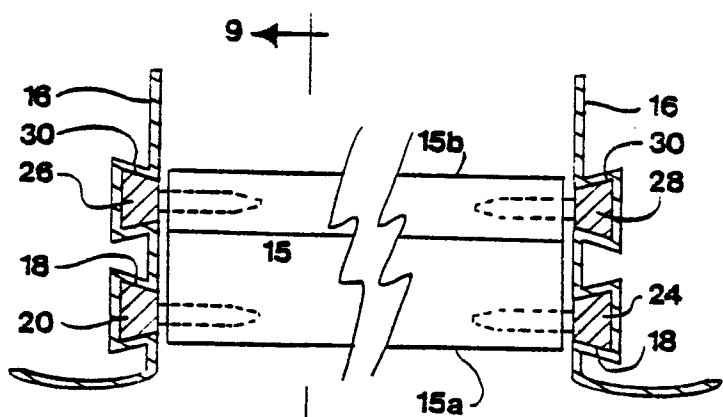

fig.9

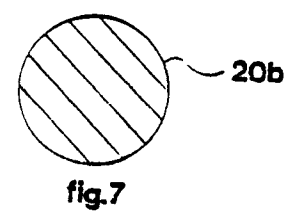

fig.7

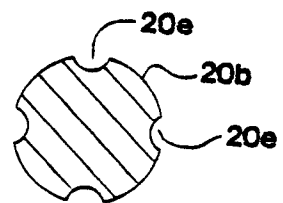

fig.8



DOCUMENTS CONSIDERED TO BE RELEVANT			
Category	Citation of document with indication, where appropriate, of relevant passages	Relevant to claim	CLASSIFICATION OF THE APPLICATION (Int. Cl.4)
D,A	US-A-4 103 601 (DAYUS) * column 3, lines 44-49; column 4, line 25 - column 5, line 14, figure 5, reference nos. 18,20; figure 14, reference no. 83 *	1,2,4,8,17-20,25	F 24 F 13/08
A	DE-A-2 229 893 (FAREX FABRIKKER A/S) * page 4, paragraph 2 - page 5, paragraph 1 *	1	
A	GB-A- 772 947 (CRITTAL & CO.) * page 1, line 74 - page 2, line 43 *	1	
A	US-A-3 800 688 (PARRISH) * column 4, lines 26-57; figure 4 *	2,4,12,13,18-21	TECHNICAL FIELDS SEARCHED (Int. Cl.4) E 06 B 7/00 F 24 F 13/00
A	GB-A-2 153 265 (ACTIONAIR EQUIPMENT LTD.) * page 1, lines 91-96 *	8	
A	US-A-3 426 667 (JOHNSON) * column 2, lines 12-17; figure 3, reference nos. 28,30 *	14	
--- -/-			
The present search report has been drawn up for all claims			
Place of search BERLIN		Date of completion of the search 24-04-1986	Examiner PIEPER C
<p>CATEGORY OF CITED DOCUMENTS</p> <p>X : particularly relevant if taken alone Y : particularly relevant if combined with another document of the same category A : technological background O : non-written disclosure P : intermediate document</p> <p>T : theory or principle underlying the invention E : earlier patent document, but published on, or after the filing date D : document cited in the application L : document cited for other reasons</p> <p>& : member of the same patent family, corresponding document</p>			



DOCUMENTS CONSIDERED TO BE RELEVANT			Page 2
Category	Citation of document with indication, where appropriate, of relevant passages	Relevant to claim	CLASSIFICATION OF THE APPLICATION (Int. Cl.4)
E	US-A-4 545 294 (DAYUS) * full text and figures * -----	1-25	
			TECHNICAL FIELDS SEARCHED (Int. Cl.4)
The present search report has been drawn up for all claims			
Place of search BERLIN		Date of completion of the search 24-04-1986	Examiner PIEPER C
<p>CATEGORY OF CITED DOCUMENTS</p> <p>X : particularly relevant if taken alone Y : particularly relevant if combined with another document of the same category A : technological background O : non-written disclosure P : intermediate document</p> <p>T : theory or principle underlying the invention E : earlier patent document, but published on, or after the filing date D : document cited in the application L : document cited for other reasons</p> <p>& : member of the same patent family, corresponding document</p>			