

⑫ **EUROPEAN PATENT SPECIFICATION**

- ⑬ Date of publication of patent specification: **29.08.90** ⑮ Int. Cl.⁵: **D 05 C 11/16**
⑰ Application number: **86830154.0**
⑲ Date of filing: **06.06.86**

⑳ **Enabling and disabling device for the needle-carrier rods and piercer-carrier rods according to a pre-settable program, in particular for a shuttle embroidery machine.**

- | | |
|---|---|
| ㉑ Priority: 21.01.86 IT 1912986 | ㉒ Proprietor: COMERIO ERCOLE S.p.A.
Via Silvio Pellico, 3
Busto Arsizio (IT) |
| ㉓ Date of publication of application:
29.07.87 Bulletin 87/31 | ㉔ Inventor: Comerio, Emilio
Via L. Manara, 4
Busto Arsizio (IT) |
| ㉕ Publication of the grant of the patent:
29.08.90 Bulletin 90/35 | ㉖ Representative: Caregaro, Silvio et al
c/o Società Italiana Brevetti S.p.A. Via Carducci
8
I-20123 Milano (IT) |
| ㉗ Designated Contracting States:
AT CH DE LI | |
| ㉘ References cited:
DE-A-2 732 038
DE-A-3 047 928
FR-A-2 499 109
US-A-2 649 065 | |

Note: Within nine months from the publication of the mention of the grant of the European patent, any person may give notice to the European Patent Office of opposition to the European patent granted. Notice of opposition shall be filed in a written reasoned statement. It shall not be deemed to have been filed until the opposition fee has been paid. (Art. 99(1) European patent convention).

Description

This invention is concerned with a device adapted to provide for enabling and disabling needle-carrier and piercer-carrier rods, in particular in a shuttle embroidery machine, according to a presettable program. It is widely known in embroidery machines the problem of enabling and disabling the needle-carrier rods and piercer-carrier rods, that is to say set them to work or stop them according to extensively variable programs, essentially related to the type of pattern one desires to obtain on the fabric.

The problem mentioned above is further increased by the fact that the needle-carrier rod actuation cuts off the piercer-carrier rod actuation, and vice versa, since as it is known, when the needles (or piercers) are active, the piercers (or needles) must be disabled. The above mentioned requirement has involved particularly complicated design arrangements in order to provide for actuation of the needle-carrier rods only, or piercer-carrier rods only, according to a particular program that can also be variable, in accordance with the desired pattern. In general, provision has been made on the machine for two separate drive systems, one for the needle-carrier rods and a second one for the piercer-carrier rods but, as it is apparent, such an approach has made the embroidery machine extremely complicated from a manufacturing and operating standpoint. In fact, the provision for two separate drive bars adapted to transmit a reciprocating motion for the operation of the needle-carrier rods and piercer-carrier rods respectively, obviously involves the requirement that two separate connection systems are provided between each drive bar and the rods (needle-carrier and piercer-carrier rods) driven thereby. In practice, the embroidery machine becomes extremely complicated, and therefore both the operation thereof and the maintenance that is possibly required, become difficult.

An embroidery machine of the kind mentioned above is disclosed in the German Utility Model No. 80 21 864 filed on August 16, 1980, assigned to Maschinenfabrik Carl Zangs AG, and issued November 13, 1980. The machine disclosed in the above mentioned patent is in fact a shuttle embroidery machine and two embodiments of the same are disclosed and claimed, having in common the feature that they are provided with a first drive bar for the reciprocating motion, engageable with the needle-carrier rods, and a second drive bar for the reciprocating motion, engageable with the piercer-carrier rods. The two embodiments mentioned above differ from each other in that, according to the first one, the coupling between the needle-carrier rods and the drive-bar thereof is obtained under the control of a first programming device comprising a splined shaft, and the coupling between the piercer-carrier rods and the drive bar thereof is obtained under the control of a second programming device comprising a splined shaft in this case as

well. In the second embodiment, the programming device comprising a splined shaft in this case as well, is a single one and it operates directly on the coupling means between the needle-carrier rods and the drive bar thereof, while it operates indirectly, through intermediate driving means, on the coupling means connecting the piercer-carrier rods to the drive bar thereof.

As it is apparent, a machine of this kind is extremely complicated, both in the first and in the second embodiment, and it is easily understood that programming such a machine is difficult, and there is a limitation to the feasible programs. This is supplemented by the fact that, when it is desired to change the operating program of the machine, it is compulsory to replace at least one or both the splined shafts of the first embodiment, or the single splined shaft of the second embodiment. This operation, besides being complicated and requiring a lot of care, obviously calls for a complete shut down of the machine.

Another embroidery machine that uses two separate drive bars for the reciprocating motion required to operate a plurality of needles and a plurality of piercers, has been disclosed and claimed in the French Patent Application No. 82 01159, filed on January 26, 1982, assigned to Adolph Saurer AG, and issued under No. 2 499 108. In fact, the machine mentioned above has a first reciprocating drive bar extending to the rear and laterally of the needle-carrier rods, and being adapted to connect to the latter through oscillating means located at the rear ends of the needle-carrier rods. In addition, the subject machine includes a second drive bar for the reciprocating motion, located underneath the first drive bar and parallel thereto, and adapted to be coupled to the piercer-carrier rods in a fashion similar to that provided for the coupling between the needle-carrier rods and the first drive bar. There is provided a complicated mechanism for operating said oscillating means which are located at the rear ends of the needle-carrier rods and piercer-carrier rods, to connect said rods to the drive bars thereof.

Taking into account what has been discussed above, the same conclusions apply for the above machine, as for the shuttle embroidery machine disclosed in the German Utility Model assigned to Karl Zangs Company.

Another machine where an attempt has been made to solve the problem of the coupling of the needle-carrier rods and of the piercer-carrier rods, to their respective drive bars, has been the subject of the German Patent Application filed on December 19, 1980, assigned to Maschinenfabrik Karl Zangs AG, and issued July 1, 1982 under No. 3 047 928.

The quite a few figures of the above mentioned Patent illustrate a needle-carrier rod and alternate solutions for the coupling of such rod to a drive bar for the oscillating motion. However, it is made apparent in the disclosure how the same coupling, in all the variations thereof which are provided, can be applied to a piercer-carrier rod. It is

therefore understandable that both the needle-carrier rods and the piercer-carrier rods are provided with their own means for connection to the drive bar, said means being always provided, for all the embodimental variations, as a magnetic means, either an electro-magnetic means or a permanent magnet means.

Therefore, all of the embodimental variations of the above patent rely upon the attractive force of a magnet means for the coupling of the needle-carrier rods, and of the piercer-carrier rods respectively, to the drive bar, which can be assumed to be single, but it is easily understood that a connection of this kind cannot guarantee a secure coupling between the rods and the drive bar. Besides, the subject machine has a particularly high energy consumption for magnet excitation, therefore its operation is highly demanding.

Another machine where an attempt has been made to solve the above problem is the one disclosed in the German Utility Model No. G 80 16375.3, filed on June 20, 1980, assigned to Mr. August Heinzle, and issued on April 30, 1981.

The shuttle embroidery machine disclosed in the subject German Patent is extremely complex, in particular as far as the shape of the needle-carrier rods and piercer-carrier rods is concerned. In fact, it is noted that said rods, which are straight and a single piece for a sufficient length to allow them to slide in appropriate guide means, bear a hinge at the rear ends thereof, where oscillating arms are pivoted, the pivoting motion thereof being controlled through a cam follower roller programming means, said arms being adapted to provide for the connection to a single drive bar.

The connection is obtained by means of notches or projections provided on said arms, which under control of said programming cam follower roller engage the oscillating drive bar.

As it is apparent, a machine of this kind is scarcely reliable, since the needle-carrier rods and piercer-carrier rods have a weakening point located at the pivot point with said swinging arms, and said pivot connection reduces the operating possibilities of the machine, in particular concerning embroidery on heavy or multi-layer fabrics, on leather or pelt, and plastic materials.

Moreover, the subject machine has the same drawback of the shuttle embroidery machine mentioned above and disclosed in the German Utility Model No. 80 21 864 to Maschinenfabrik Karl Zangs AG. in that, in order to change the sewing program, it is compulsory to change the programming cam follower roller and consequently the machine has to be shut down.

Besides, the connections between the oscillating arms and the oscillating drive bar seem to be scarcely reliable, since they are entrusted completely to the coupling between a projection provided on the oscillating arm, and the oscillating drive bar, even though in some embodimental variations of the subject machine, resilient means are provided to enhance said coupling. A further drawback of the same machine resides in the fact

that, in order to be able to prearrange the needle-carrier rods aligned on a plane, and the piercer-carrier rods aligned on an underlying plane, the oscillating arms associated with the piercer-carrier rods are elbow-shaped, which makes even more critical the actuating conditions of these rods. In fact, the transmission of motion from the oscillating drive bar to the piercer-carrier rod does not take place along a straight line, but rather along an S-shaped body whereby an accordingly high stress condition prevails in the intermediate span thereof.

Besides, all of the above mentioned machines are highly noisy in operation, which is very inconvenient for the machine operators.

There has now been contrived, and it is the subject of this invention, a device for enabling or disabling the needle-carrier rods, or the piercer-carrier rods in an embroidery machine having a single reciprocating motion drive bar, which device overcomes the drawbacks mentioned above.

It is worthy of note the fact that the subject device uses, for the coupling of the needle-carrier rods and of the piercer-carrier rods to the single drive bar thereof, the already tested connection system that was used for the embroidery machine disclosed in Italian Patent No. 1.182.146 filed on July 28, 1976, in the name of the same Applicant, and issued June 5, 1983.

As it will become apparent from the following, a connection of the type specified is embodied as a laterally sliding pin which is insertable in the needle-carrier rod, or piercer-carrier rod, whose lower end, when in its lowered position, engages the oscillating motion driving bar and, by cooperation with a pin integral with the needle-carrier rod which engages the oscillating motion driving bar on the opposite side, integrally connects the latter to the needle-carrier rod, or to the piercer-carrier rod. The disengagement of the needle-carrier rod, or piercer-carrier rod, from the drive bar is carried out by raising the pin mentioned above, and this operation is performed by means of a small lever rotatable on said needle-carrier rod, or piercer-carrier rod, and having one end connected to, and more particularly pivoted on, the upper end of the connecting pin mentioned above. Actuation of the above mentioned small levers is carried out by means of a control lever for each of said levers mounted on the needle-carrier rod or piercer-carrier rod whose raising or lowering results in a respective lowering or raising of the connection pin, followed by engagement and disengagement of the needle-carrier rod or piercer-carrier rod relative to the drive bar.

A connection system of this kind, that has proved thoroughly reliable and free from annoying noise generation, has been used as well in Patent Application No. 24099A/82 filed November 5, 1982 in the name of the same Applicant. Through the development of the initial concept of the above mentioned Italian Patent of the same Applicant, this machine has made it possible to obtain a device adapted to perform needle inser-

tion and/or withdrawal in an embroidery machine, according to widely variable programs and also while the machine is in operation, i.e. doing away with the considerable drawback of having to shut down the machine when the sewing program has to be changed.

The device according to this invention is a particularly advantageous further development of the machines disclosed in the Patent and in the Pat. Application mentioned above, of the same Applicant, and the features as well as advantages thereof will become apparent from the following detailed description of a non limiting embodiment thereof, where reference is made to the attached drawings, in which:

Figure 1 is a partially cutaway perspective view of the embroidery machine provided with the device in accordance with this invention;

Figure 2 is a side sectional view showing a piercer-carrier rod actuation;

Figure 3 is a view similar to Figure 2, showing the device according to this invention, in the condition where the piercer-carrier rod is disabled or idle;

Figure 4 is a cross section showing how a piercer-carrier rod is manually disabled;

Figure 5 is a cross-section showing how a needle-carrier rod is actuated;

Figure 6 shows how a needle-carrier rod is brought from the active position into an idle position;

Figure 7 is a schematic showing the device of this invention, along section line VII—VII of Figure 2.

Referring first to Figures 1 and 5, the machine in accordance with this invention includes a plurality of needles, carried in a known manner by means of a clamping block 2, by needle-carrier rods 3, slidable in a guide 4 (Figure 1) formed in cross member 5 of the machine frame. Rods 3 are located in a horizontal plane, spaced at predetermined intervals, and slide in the same plane, along direction A—A of Figure 5, perpendicular to fabric T, shown by a chain line. Actuation of the needle-carrier rods 3, i.e. their coupling to drive bar 6 reciprocating according to the direction indicated by the double-pointed arrow F in Figure 5, is provided as specified below and, as it has been mentioned above, this coupling is related to the coupling features used in the aforementioned patents of the same Applicant, which have made it possible to thoroughly develop and complete the innovational concept of the inventive device, which will be explained in the following. The coupling between needle-carrier rods 3 and drive bar 6 mentioned above is hereinafter recalled in the essentials thereof, for ease of understanding.

At the end thereof opposite to the one where needle 1 is fastened, each needle rod 3 is provided with a block 7 fastened in a general fashion to said end of the needle-carrier rod 3. Underneath block 7 there is provided a projection 8 for engagement with the rear face of drive bar 6.

On the upper side of block 7 there is provided a substantially L-shaped control arm 9, having

slightly divergent sides making an angle higher than 90°, a side 9a thereof extending substantially upward, while the second side 9b slopes downwardly with the front end thereof inserted in a connecting pin 10 slidably engaged in a transverse opening located in a substantially rear portion of needle-carrier rod 3. Connecting pin 10 protrudes down from needle-carrier rod 3, and the end portion thereof projecting out from said rod is meant to come into engagement with drive bar 6, and in particular with an upper projection 6a thereof.

In such a position, drive bar 6 is retained between projection 8 of block 7 fastened to needle-carrier rod 3, and the lower end of pin 10 projecting from said needle-carrier rod 3. Therefore, as it is shown in particular in Figure 5, the latter is forced to follow the motion of drive bar 6, i.e. to reciprocate between the full line position and the dashed line position. This is the enabled condition of needle-carrier rod 3, in which needle 1 associated thereto performs a normal sewing operation.

Needle-carrier rod 3 can be brought to a disabled condition where it is disengaged from drive bar 6. That is made possible by raising connecting pin 10 up to the position shown in Figure 6, where the pin is completely disengaged relative to drive bar 6. Raising of connecting pin 10 is provided through counterclockwise rotation of control arm 9. To that end, drive arm 9 is pivoted on a pivot shaft 11 carried by a fork member 12 located on the upper part of block 7. Said counterclockwise rotation is carried out against the bias of a spiral spring (not shown) coaxial to pivot shaft 11 and acting in such a way as to bias control arm 9 to the position shown in Figure 5, where it arranges connection pin 10 in engagement with drive rod 6. Therefore, the counterclockwise rotation necessary to disengage connection pin 10 from drive bar 6 is carried out against the bias of the resilient means mentioned above.

Referring now in particular to Figures 1 to 3, the embroidery machine provided with the device according to the invention has a plurality of piercers 13 known per se. Contrary to the known machine practice, they are not fastened directly to the corresponding piercer-carrier rod 14 which is in turn connected to drive bar 6, but they are mounted on a square bracket 15 connected to said piercer-carrier rod 14 which consequently subjects said piercers 13 to the required reciprocating motion. Said square brackets 15 are shown in detail in Figure 1, but they can be seen sideways in Figures 2 and 3 and, as it is shown in said Figures, said square connecting brackets 15 comprise a substantially L-shaped body allowing the piercer 13 to be located exactly underneath sewing needles 1, as it is apparent from Figure 1, while piercer-carrier rod 14 is displaced sideways relative to needle-carrier bar 3, and in the same plane thereof, as it can still be seen from Figure 1. This arrangement is particularly convenient since, without any particular design complications, needles 1 and piercers 13 operate along parallel

and superimposed directions, therefore very close as required in any embroidery machine.

The transmission of reciprocating motion of piercer-carrier rod 14 to the piercer 13 by means of square bracket 15 is carried out as follows.

Front end 16 of piercer-carrier rod 14 is inserted in an opening provided in the upper portion of vertical side of square connecting bracket 15, being fastened thereto by means of a set screw 17. In this way, when rod 14 reciprocates according to the direction of double pointed arrow G of Figure 2, it draws therewith square connecting bracket 15 that reciprocates accordingly between the full line position and the dashed line position.

As it appears in particular from Figure 1, square connecting bracket 15 has fastened to it the end 18 of a rod 19, which is slideably engaged within a bore 20 provided through cross member 5, exactly underneath bore 21, provided through cross member 5 as well, wherein piercer-carrier rod 14 is slideably engaged. More particularly, front end 18 of rod 19 is fastened at the corner of square connecting bracket 15, in any way well known, similar to end 16 of piercer-carrier rod 14, i.e. for instance by means of a set screw (not shown).

Therefore, rod 19 reciprocates in the same vertical plane wherein the path of motion of underlying piercer-carrier rod 14 is located.

Piercer 13 is fastened in any way known per se to the free end of the horizontal side of square connecting bracket 15, projecting from the front thereof, as it is apparent in particular from Figures 1 to 3.

The main purpose of rod 19 is not to transmit a driving motion to piercer 13, since that is performed by square connecting bracket 15 adapted to transmit directly to piercer 13 the reciprocating motion of rod 14. Rod 19 is provided in order to inhibit rotation of square connecting bracket 15 in a plane substantially perpendicular to the plane where the reciprocating path of rod 19 is contained. Therefore, rod 19 main function, is a stabilizing function for piercer 13 motion, so that the same is always straight and always takes place along the same path which is therefore positively located underneath the path of sewing needle 1.

Coupling and uncoupling of piercer-carrier rod 14 relative to drive bar 6 takes place in a way substantially similar to that of needle-carrier rod 3, therefore the devices provided for that purpose, in addition to bearing the same reference numbers are not described in detail, but only the essential components thereof are mentioned. In Figures 2 and 3 block 7 is noticed, fastened to the rear portion of piercer-carrier rod 14. On the upper part thereof it is rotatably mounted control arm 9, in engagement with pin 10 connecting piercer-carrier rod 14 to drive bar 6. In the condition shown in Figure 2, connecting pin 10 is located in the lowered position and drive bar 6 is therefore retained between projection 8 of block 7 and the lower end of connecting pin 10. In this way, piercer-carrier rod 14 performs a reciprocating

motion as it is shown by dashed lines in Figure 2, and piercer 13, through the connection described above, performs a reciprocating motion as well, still shown by dashed lines in Figure 2.

Disengagement of piercer-carrier rod 14 from drive bar 6, and therefore the stopping thereof, is obtained by raising connecting pin 10, as it is shown in Figure 3, so that it disengages from drive bar 6 reciprocating according to the direction of double pointed arrow H of Figure 3 without carrying piercer-carrier rod 14 therewith. Raising of connecting pin 10 is provided by moving control arm 9 with a counterclockwise rotation against the bias of said resilient means (not shown in this case either) provided on the pivot shaft 11 thereof, and said operation is carried out as it will be explained more particularly in the following.

It should now be noticed, referring to Figures 2 and 3 as far as piercer-carrier rods 14 are concerned, and to Figure 5 as far as needle-carrier rods 3 are concerned that substantially upright branch 9a of control arm 9 is slideably engaged within a longitudinal slot 22 machined through a heavy plate 23 which is fastened at the front end thereof to the stationary cross member 5 of the embroidery machine frame, and at the rear portion thereof to a further stationary cross member 24 which is a part of the embroidery machine stationary frame as well. The number of longitudinal slots 22 is equal to the sum of the number of needle-carrier rods 3 and piercer-carrier rods 14, since each of said rods is provided with a control arm 9, and therefore with a branch 9a which has to be slidable in a slot 22 thereof. This should become apparent from an examination of Figure 1, wherein the embroidery machine has been only partially shown and, as it can be seen, there is provided a slot 22 for each branch 9a of arms 9, both the ones associated with a needle-carrier rod 3, and the ones associated with a piercer-carrier rod 14.

Moreover, the upper ends of branches 9a of control arms 9 always project above the heavy plate 23 through slots 22, both in the engaged position of needle-carrier rods 3 and of piercer-carrier rods 14 (Figure 5 and Figure 2), and in the disengaged position of said rods relative to drive bar 6 (Figure 6 and Figure 3). As shown above, the coupling and disengagement of needle-carrier rods 3 and of piercer-carrier rods 14 relative to drive bar 6 is obtained in both cases through a counterclockwise rotation of control arm 9, which causes connecting pin 10 to raise, or viceversa through a clockwise rotation of control arm 9 which allows the connecting pin 10 to lower and to come into engagement with drive bar 6, through the bias of a spiral spring (not shown) mounted on pivot shaft 11. Said operations, both concerning needle-carrier rods 3 and concerning piercer-carrier rods 14, are obtained as explained in detail in the following.

As it may be seen in particular in Figure 1, but it is also apparent from Figures 2, 3 and 5, each

needle-carrier rod 3 and each piercer-carrier rod 14 has associated therewith, above heavy plate 23, a control lever 25 extending above slot 22 and therefore above control arm 9, and engaged in particular with branch 9a thereof. Therefore, the number of control levers 25 will be equal to the total of the number of needle-carrier rods 3 and the number of piercer-carrier rods 14.

Each control lever 25 is comprised, in the embodiment shown herein, of a substantially straight metal section which is provided, close to an intermediate area thereof, with a bent portion 26 through which it engages the upper end of branch 9a of control arm 9.

Levers 25 are pivoted, at the front end thereof, i.e. on the needle 1 and piercer 13 side, on a common shaft 27, mounted on support lugs 28 that are fastened, at the lower end thereof, in a transverse groove 29 provided on top of the stationary cross member 5. More particularly, support lugs 28 are inserted all the way, with a substantially close fit through heavy plate 23, so that they are fastened, at the lower end thereof, in groove 29 of stationary cross member 5. In Figure 1 there is partially shown support lugs 28, and more particularly the ones among them which are associated with the control levers 25 shown therein. As it is apparent, both the remaining levers 25 and lugs 28 are identical to the ones shown.

Referring now in particular to Figures 2 and 3, there is illustrated the actuating mechanism of levers 25 which are associated with piercer-carrier rods 14 and, therefore, the way they cause the disengagement of piercer-carrier rods 14 from drive bar 6 is shown. Referring first to Figure 2, levers 25 can take the position shown in said Figure, and this should be considered the "raised" position, where branch 9a of control arm 9 is not biased to turn counterclockwise, whereby it keeps connecting pin 10 in a lowered position where the lower end thereof engages drive bar 6 thereby providing for the coupling between piercer-carrier rod 14 and drive bar 6. Control levers 25 can take a second position as well, i.e. the one shown in Figure 6, which can be considered the "lowered" position wherein branch 9a of control arm 9 is biased to turn counterclockwise whereby the second branch 9b of control arm 9 causes connecting pin 10 to raise and consequently disengage from drive bar 6. piercer-carrier rod 14 is now in the disabled, i.e. non operating condition.

The means controlling the above mentioned motion of levers 25 from the position shown in Figure 2 to that shown in Figure 3, and vice versa, are described in the following.

Said means include, for each control lever 25, a vertically extending slender rod 30 connected at the top thereof to the rear end portion of control lever 25. For that purpose, slender rod 30 projects above rear cross member 24 through a bore 31 thereof, wherein it is slidably accepted. On the upper end of slender rod 30 there is fastened in any known way a fork member 32 provided with a

cross pin 33 whereon an enlarged portion 34 of rear end portion of control lever 25 is pivoted. Between the body of fork member 32 fastened at the upper end of slender rod 30 and the upper surface of cross member 24 there is inserted resilient means, comprising a coil spring 35 arranged around slender rod 30. Spring 35 purpose is to allow for a temporary rotation of control lever 25 around pivot pin 27, as it is shown in Figure 3, then driving it to turn in the opposite direction to the position shown in Figure 2 at the end of the action of the means controlling the motion of slender rod 30, which are provided at the lower end thereof, as it will be described.

Furthermore, spring 35, as it is apparent in particular from Figure 2, keeps control lever 25 slightly raised relative to branch 9a of control arm 9, to avoid that, when needle-carrier rod 3 and piercer-carrier rod 14 are enabled, said branch 9a of control arm 9 rubs against the lower surface of control lever 25.

At the lower end of slender rod 30 there is fastened a tailpiece 36 comprising a substantially rectangular body whose length is large compared to the width thereof, the width being slightly larger than slender rod 30 diameter. On a face of tailpiece 36, more particularly on the face located on the side of fabric T, there is provided an upper projection 37 and a lower projection 38, substantially of the same length. On the rear portion of the upper projection 37 there is provided a step 39 whose purpose will become apparent in the following. In the lower portion of the frame of the embroidery machine provided with the device according to this invention there is provided referring in particular to Figure 1, guide means of tailpieces 36 associated with needle-carrier rods 3 (and of tailpieces associated with piercer-carrier rods 14 which will be mentioned in the following), said guide means comprising a substantially L-shaped section 40 whose horizontal side 41 is substantially comb-shaped, being provided for said purpose with a plurality of substantially rectangular projections 42 which define slots 43 of tailpieces 36. Advantageously, section 40 is supported in any known way by a support angle section 44 substantially L-shaped as well, which supports vertical side of section 40 fastened to vertical side 45 thereof.

As described above, the lowering of slender rods 30 in a vertical direction makes control levers 25 to rotate counterclockwise with a corresponding counterclockwise rotation of control arms 9 associated with the piercer-carrier rods 14 which are in turn disabled. Said operation is automatically performed through a single drive shaft 46 provided with a control arm 47 radially projecting therefrom and which simultaneously comes into engagement with all the lower projections 38 of tailpieces 36. In this way, when known means (not shown) make shaft 46 to rotate counterclockwise, according to the direction of arrow S in Figure 3, arm 47 engaging with all the projections 38 of tailpieces 36, makes slender rods 30 to lower with a counterclockwise rotation of control levers 25

which disables all the piercer-carrier rods 14. The device according to this invention also includes means to keep temporarily locked the slender rods 30 in the lowered position thereof, said means allowing, in the disabled condition thereof, a raising of any number of slender rods 30 according to a predetermined sewing program. Said means are described hereinafter. The means keeping the slender rods 30 temporarily locked in the lowered position thereof, being also adapted to allow for a plurality of slender rods to raise thereafter according to the sewing program include a plurality of substantially L-shaped metal plates 48 which, at the corner 49 thereof are freely pivoted on a common shaft 50 extending for the whole length of the embroidery machine. The number of metal plates 48 is equal to the number of slender rods 30 associated to the piercer-carrier rods 14, or to the (equal) number of the remaining slender rods associated to the needle-carrier rods 3, and discussed in the following. In fact, as it will become apparent in the following, this is due to the fact that each metal plate 48 engages simultaneously with a projection 62 of a tailpiece 60, and with the projection 37 of tailpiece 36 adjacent thereto.

As it will be noted in particular from Figures 1 to 3, and also from Figure 7, vertical side 51 of metal plates 48 is substantially bent with the concave side thereof facing the slender rods 30 and the lower edge thereof comes into engagement, at least with a portion thereof, with step 39 of tailpiece 36 integral with slender rod 30 when the latter has been brought in the lowered position thereof through the action of drive shaft 46 shown in detail in Figure 3.

To keep all the slender rods 30 in the lowered position thereof, which disables all the piercer-carrier rods 14 accordingly, it is therefore enough that shaft 46 is rotated in the direction of arrow S, so that the arm 47 thereof, coming into engagement with projections 38 of tailpieces 36, causes the slender rods 30 to lower.

Subsequently all the metal plates 48 are brought to the position shown in Figure 3, in a way that will be described in detail hereinafter, and in this position a portion of lower edge of vertical side 51 of metal plates 48 comes into engagement with step 39 of tailpieces 36. There are now two operating alternatives for the embroidery machine: according to the first one, the piercers 14 are kept disabled, so that shaft 46 is kept in the position shown in Figure 3, while, according to the second one, it is possible to enable a plurality of piercers 16 and in this case provision is made to cause in a way per se known a rotation of shaft 46 in a opposite direction compared to the first alternative, so that slender rods 30 are kept at first in the lowered position due to the arrangement of metal plates 48 mentioned above. Thereafter, slender rods 30 can be raised again, according to the predefined program, by disengagement of metal plates 48, i.e. moving vertical side 51 in an opposite direction as it is diagrammatically shown in Figure 4, so that

the lower edge of said metal plates comes out of engagement with step 39 of tailpiece 36, to enable the number of slender rods 30 involved to move up again to the "raised" position under the bias of spring 35 as it is more particularly shown in Figure 2. All the piercer-carrier rods 14 associated to said slender rods at this point will be enabled again.

The means controlling the rotations of metal plates 48 for engagement and disengagement relative to tailpieces 36 preferably comprise electromagnet means 53 whose core is carried by a bracket 54 in turn fastened in any known way underneath a heavy stationary plate 55 which is part of the embroidery machine frame, whereon there is also supported shaft 50 where the metal plates 48 are pivoted.

Rod 56 comprising the moving element of electromagnet means 53, has a fork-shaped free end 57 only one prong of which is shown in Figures 2 and 3, said end 57 being shown in cross-section. On the front portion of forked end 57 of rods 56 there is provided a cross pin 58, and vertical side 51 of metal plates 48 is inserted in the space between said pin 58 and bottom 59 of the forked end 57 of rods 56. In this way, when rods 56 are in the position shown in Figure 2, i.e. said rods are recalled in the core of electromagnet means 53, metal plates 48 are disengaged from tailpieces 36 associated therewith, in that side 51 is rotated counterclockwise due to its engagement with pin 58 of rods 56. This actuation of electromagnet means 53, in particular the re-entry of rods 56 thereof in the respective core is carried out electromagnetically, in that all the electromagnets 53 where it is desired that rod 56 is recalled within the core thereof, are supplied with a suitable voltage, causing the motion mentioned above. On the contrary, as it is noticed in particular in Figure 3, when rods 56 of electromagnet means 53 are caused to project from the core of said means, pin 58 of forked end 57 of rods 56 comes out of engagement with vertical side 51 of plates 48, while the latter now comes into engagement with the bottom 59 of the forked end 57 of rods 56 causing a clockwise rotation, opposite to the former one of vertical side 51 whose lower edge then comes into engagement with step 39 of tailpiece 36. This second actuation of electromagnet means 53, i.e. the projection of rods 56 out of the respective core, is obtained in a purely mechanical manner in that, on each rod 56 there is wound a coil spring 80 which engages, at a first end thereof, against support bracket 54 for the electromagnet means 53, and at the other end thereof, against side 51 of plate 48. When it is desired that rods 56 are projected out of the core of electromagnet means 53, it is enough that the latter are de-energized so that the spring can cause said motion spontaneously, by a resilient action.

Referring now in particular to Figure 5, there will be discussed the way in which the enabling and disabling of needle-carrier rods 3 is carried out, i.e. how they are brought to the operating

condition, or to the disabled condition. In this respect, the operation and the structure of the inventive device are substantially the same as those used for enabling and disabling piercer-carrier rods 14. Therefore, for this part of the invention only the main points will be recalled, and the same members are indicated with the same reference numbers, and the differences will be pointed out. Figure 5 shows one of the needle-carrier rods 3 in the operating condition, i.e. wherein needle 1 is in the sewing phase, and therefore needle-carrier rod 3 is coupled to drive bar 6. The illustration of the same part of the device shown in Figure 5 with the needle-carrier rod 3 in the disabled condition has been omitted, since this condition can be easily derived both from Figure 5 and in that it is completely similar to the corresponding operating phase of the piercer-carrier rods 14.

Referring to said Figure, needle-carrier rod 3 is connected to drive bar 6 in that connecting pin 10 is in the lowered position thereof since control lever 25 associated therewith is in its "raised" condition. Spring 35 is in the extended condition thereof, in which it keeps control lever 25 raised slightly above branch 9a of control arm 9 and correspondingly raises slender rod 30 which is pivoted above said control lever. Connection between slender rod 30 and control lever 25 is identical to that of the corresponding levers associated with piercer-carrier rods 14.

Slender rod 30 is provided, in the lower portion thereof, with a tailpiece 60 of a substantially rectangular shape having a considerable length compared to the diameter of rod 30, while its width is slightly larger than the latter. Tailpiece 60, in the upper part thereof, is provided, on opposite faces, with two projections 61 and 62, rear projections 61 facing the rear portion of the embroidery machine, while projection 62 faces the same side of projections 37 and 38 of tailpieces 36. The length of projections 61 and 62 is substantially the same as the length of projections 37 and 38 of tailpieces 36.

To control lowering of slender rods 30 associated with said tailpiece 60, i.e. to disable a needle-carrier rod 3 against the bias of spring 35, there is provided a second drive shaft 63 supported in any known way by the machine frame, and which is provided with a radially projecting arm 64, similar to arm 47 associated to drive shaft 46, adapted to come into engagement at the end thereof with rear projections 61 of tailpieces 60. To disable simultaneously all the needle-carrier bars 3, it is enough to cause the lowering of all the slender rods 30 associated therewith and for that purpose a clockwise rotation of drive shaft 63 is actuated, whose direction is indicated by arrow R in Figure 5, and the motion of the shaft and associated arm that follows, is illustrated in Figure 6, where arm 64 is shown by a dashed line in the raised position thereof, and by a full line in the rotated position thereof.

It should be noted that arm 64 associated with second drive shaft 63, similarly to arm 47 asso-

ciated with first drive shaft 46, is a continuous flat body, comparable to a slab, and as it is apparent in particular from Figure 1, it extends the whole length of the drive shaft, either 63, or 46 if reference is made to arm 47. The fact that arm 47 of first shaft 46 comes into engagement only with projections 38 of tailpieces 36 connected to slender rods 30 associated with piercer-carrier rods 14, while arm 64 of second drive shaft comes into engagement only with projections 61 pertaining to tailpieces 60 of slender rods 30 associated with needle-carrier rods 3, is due to the particular shape of tailpieces 36 and 60, to the mutual location of tailpieces projections, and, in addition, to the fact that first and second drive shafts 46 and 63 are mutually offset heightwise as it is apparent in particular from Figure 2.

In fact, projections 38 of tailpieces 36 are located in the lower front part of said tailpieces, while tailpieces 60 are not provided with lower projections. Therefore, no interference is possible between arm 47 of first drive shaft 46 and tailpieces 60. Projections 61 of the latter, that are engaged by arm 64 of second drive shaft 63, are located upwards and rearwards. On their rear side tailpieces 36 do not have any projection. Therefore, in this case as well interference is precluded between arm 64 of second drive shaft 63 and the tailpieces 36. On the contrary, projections 37 on tailpieces 36, and projections 62 of tailpieces 60 being provided in order to keep the various slender rods 30 in the lowered position thereof in cooperation with plates 48 are located on the same side, and substantially at the same height. This is so in that electromagnet means 53 and plates 48 are all located on the same side of slender rods 30, i.e. on the side where needle-carrier rods 3 and piercer-carrier rods 14 come out. This way, as it can be noticed in particular from Figure 5, also in connection with tailpieces 60 associated with needle-carrier rods 3, the relevant front projections 62 cooperate with plates 48 actuated by electromagnet means 53, as it can be seen in more detail from plan view of Figure 7 which shows exactly the mutual location of vertical side 51 of a plate 48 relative to two adjacent tailpieces 36 and 60, and more particularly relative to respective front projections 37 and 62. It is apparent from the Figures that vertical side 51, at a portion thereof (more precisely the right side portion looking at Figure 7) engages with projections of tailpiece 36 of slender rod 30 associated with a piercer-carrier rod 14, while at the other end portion (the left side portion in Figure 7) it comes into engagement with projection 62 of tailpiece 60 pertaining to slender rod 30 associated with a needle-carrier rod 3.

The device according to this invention when enabling or actuating a predetermined group of needle-carrier rods 3, operates in the same way as when enabling piercer rods 14. For reasons of clarity only, the essentials of this operation are recalled hereinafter.

Starting from the situation shown in Figure 5, wherein all the needle-carrier rods can be

assumed to be enabled, (for instance when the machine is shut down) a clockwise rotation, for instance according to the direction of arrow T of Figure 5, is given to second drive shaft 63, so that arm 64 thereof causes all the tailpieces 60 (and therefore the slender rods 30) to lower because of the engagement with projections 61 pertaining to said tailpieces. At this point, all of the needle-carrier rods 3 are disabled and, as in the preceding case of the piercer-carrier rods 14, a double choice is possible. A first alternative is that provision is made so that all the needle-carrier rods 3 remain disabled, therefore drive shaft 63 remains in the rotated position as it was described above, and so that first drive shaft 46 is actuated in order to allow slender rods 30 associated with piercer-carrier rods 14 to raise, when corresponding plates 48 are disengaged by electromagnet means 53. As it is apparent, for each actuated plate, in this case those slender rods 30 will raise that are associated with piercer-carrier rods 14, while those associated with needle-carrier rods 3 will remain in the lowered position thereof, because of the bias of second drive shaft 63.

A second alternative, corresponding to the one mentioned above for piercer-carrier rods 14, corresponds to providing for a plurality of needle-carrier bars 3 to be returned to the operating condition. In this case, while on one hand drive shaft 46 is kept in the rotated position, i.e. with arm 47 thereof in the lowered position, and all the piercer-carrier rods 14 are disabled, on the other hand second drive shaft 63 is rotated in a direction opposite to the former one to cause it to disengage from projections 61 of tailpieces 60 pertaining to slender rods 30 associated with needle-carrier rods 3, said tailpieces 60 then remaining in their lowered position for engagement with corresponding plates 48. When a plurality of plates 48 disengage from tailpieces 60 and 36, the latter will be allowed to raise both because of the position taken by the second drive shaft 63 and because of the action of springs 35, while on the other hand all the tailpieces 36 associated with piercer-carrier rods 14 will remain in the lowered position thereof for the above mentioned reason.

The device according to this invention, owing to the operation it provides as discussed above, offers two alternatives and in particular a first alternative corresponding to energizing a certain number of electromagnets 53 to disengage plates 48 while a drive shaft, for instance first shaft 46, is in the rotated position thereof, so that piercers 13 are not actuated. A second alternative corresponds as well to energizing a certain number of electromagnet 53 while on the contrary the second drive shaft is kept in the rotated position, so that all the needle-carrier rods 3 are disabled. Simultaneously, the first drive shaft is rotated in a direction opposite to the preceding one, which had provided for lowering the tailpieces 36 associated with piercer-carrier rods 14. Both the above alternatives, and in particular the actuations of electromagnet means 53, can be programmed on

purpose by electronic means, so that the functions and overall operation of the embroidery-machine are completely automated.

In addition, the device according to this invention leaves the possibility for manual manipulation in order to insert, when it is desired, one or more needle-carrier rods 3, or one or more piercer-carrier rods 14. Said possibility is granted in that an additional plurality of thin drive rods 65 are located in the upper part of the machine and extend vertically between two of the adjacent slender rods and in a position slightly backwards therefrom, and more precisely between a slender rod 30 associated with a needle-carrier rod 3 and a slender rod 30 associated with a piercer-carrier rod 14. Said additional thin rods 65 are located above horizontal side 52 of plates 48, and the operation will be explained referring now to Figure 4, respectively for a piercer-carrier rod 14 and for a needle-carrier rod 3, even though operation for the first kind of rods is perfectly symmetrical compared to the operation for the second kind of rods.

More precisely, Figure 4 refers to preceding Figure 3, i.e. it shows the portion of the device concerning a piercer-carrier rod 14. However, it is enough to extend said Figure, without resorting to another illustration, to the case of a needle-carrier rod 3, being only necessary to consider Figure 4 and replace tailpiece 60 to tailpiece 36, and second drive shaft 63 to first drive shaft 46, for the operation of this rod 65 of needle-carrier rod 3 to become apparent.

Considering first Figure 4, concerning the case of a piercer-carrier rod 14, it can be noticed that first drive shaft 46 is in the upwards rotated position and, in fact, arm 47 thereof is substantially horizontal and raised relative to projection 38 of tailpiece 36. The latter is kept in the lower position thereof with a corresponding disengagement of piercer-carrier rod 14 from plate 48 whose side 51 engages with upper projection 37. Simultaneously, side 58 of plate 48 engages with projection 62 pertaining to tailpiece 60 associated with a needle-carrier rod 3, but, as it has been mentioned above, it should be noticed that second drive shaft 63, as shown in Figure 6, is now in the downwards rotated position thereof and its arm 64 engages against projection 61 of tailpiece 60. Apparently, for the subject case, where actuation of a piercer-carrier rod 14 is desired, second drive shaft 63 will be kept in the position shown in full line in Figure 6, so that actuation of plate 48 as mentioned above will cause tailpiece 60 to remain in the lowered position and the associated needle-carrier rod 3 will be kept disabled.

If it is desired that piercer-carrier rod 14 is brought to operating in such enabled condition, during the normal operation of the embroidery machine as well, it is only required to exert pressure on upper L-bent end 66 of thin rod 65 for related lowering thereof, so that its lower end, coming into engagement against horizontal side 52 of plate 48, drives the latter to rotate counter-

clockwise therefore disengaging its vertical side 51 from projection 37 pertaining to tailpiece 36. As a result of this operation, slender rod 30 under the action of spring 35 will return to the "raised" position thereof and as a consequence a clockwise rotation of lever 25 enables a corresponding clockwise rotation of control arm 9 which causes connecting pin 10 to lower into engagement with drive bar 6. Lowering of thin rod 65 and the related rotation of plate 48 are shown by dashed lines in Figure 4.

Once this operation has been accomplished, thin rod 65 automatically returns to the starting position being biased by a return spring 67, which operates between a cross member 68 located underneath stationary cross member 24 and provided with a bore 69 for through passage of thin rod 65. A sleeve 70, fastened in any known way on thin rod 65, is adapted to provide a stop for the raising thereof. Sleeve 70 too is shown by full lines in the raised position, and by dashed lines in the lowered position.

Similarly to what has been discussed above for the piercer-carrier rods 14, there is provided the possibility of manual insertion for needle-carrier rods 3 as well. Said possibility is briefly described in the following, still referring in particular to Figure 4, but referring now, for clarity, to Figures 3 and 6 as well.

It is assumed that thin rod 65 is the same one mentioned above, since as it has been explained already, each plate 48 simultaneously engages with both the tailpieces of two slender rods 30 adjacent to each other, associated respectively with a piercer-carrier rod 14 and with a needle-carrier rod 3. In this case too, thin rod 65 is in the raised position, as shown in Figure 6, and tailpiece 60 is kept in the lowered position, which results in the uncoupling of needle-carrier rod 3 from plate 48. At first, provision has been made to rotate second drive shaft 63 counterclockwise, so that the arm thereof is brought to the upwards turned position shown by dashed lines. Simultaneously, first drive shaft 46 is kept in its downwards rotated position, as shown in Figure 3, so that arm 47 thereof, engaging with the projections of all the tailpieces 36 keeps the same, and therefore all the slender rods 30 connected thereto, in the lowered position which results in the disabling of the piercer-carrier rods.

If manual actuation of needle-carrier rods 3 is desired, it is enough to manually operate thin rods 65, in a way similar to what has been described for piercer-carrier rods 14, i.e. lower them so that plate 48, and in particular lower edge of vertical side 51 thereof, disengages from projection 62 of tailpiece 60 moving to the position shown by dashed lines. Similarly to the case of piercer-carrier rods 14, in this case too the electromagnet means 53 are not energized, so that the moving member thereof, comprising rods 56 can be freely displaced against the bias of spring 80.

Once enabling of needle-carrier rod 3 has been obtained, in the way mentioned above, thin rod

65 returns to the starting position thereof, i.e. in its raised position, under the action of spring 67.

Eventually, the device according to this invention provides a further advantageous operating alternative, comprising the possibility to manually disable one or more needle-carrier rods 3, or piercer-carrier rods 14. Said operation is now explained referring in particular to Figure 2, for one piercer-carrier rod 14 only since identical operation takes place for a needle-carrier rod 3.

Referring now to said Figure, piercer-carrier rod 14 is enabled, and to have it disabled it is only required to press on rear end portion of control lever 25, so that slender rod 30 associated therewith is lowered, and, the electromagnet 53 being de-energized, it will be permanently tensioned spring 80 itself to cause a clockwise rotation of plate 48, and therefore the engagement thereof with projection 37 of tailpiece 36, to keep the latter in a lowered position.

As a direct consequence of said operation, it will be possible to actuate again piercer-carrier rod 14 through energization of electromagnet 53.

From what has been described above, there becomes apparent the various operating alternatives of the embroidery machine provided with the device according to this invention, which enables the same machine to be preset according to several different and modifiable programs, said programming being easily and rapidly done, so that the operating speed of the machine is very high. Moreover, all the control means of the device according to this invention, obviously excepting the manual control, can be completely automated. It should be noted for that purpose that, besides an electronically controlled programming of electromagnet means 53, it is also possible to electronically program the actuation of drive shafts 46 and 63. Therefore, the machine is extremely versatile, reliable, and has a very high performance.

In conclusion, it is apparent that variations and/or modifications can be made to the device according to this invention, without exceeding the scope of protection of the same.

Claims

1. Enabling and disabling device for needle-carrier rods and piercer carrier rods according to a presettable program, particularly in a shuttle embroidery machine, including means to couple and uncouple said rods relative to a drive bar adapted to transmit a reciprocating motion thereto, and control means of said means to couple and uncouple needle-carrier rods and piercer-carrier rods relative to the drive bar characterized in that said control means include an assembly of movable rods (30) located in the back of, and transversally to, said needle-carrier rods (3) and said piercer-carrier rods (14) and are each connected, in the upper portion thereof, to a control lever (25) cooperating with said means to enable and disable said needle-carrier rods (3) and said piercer-carrier rods (14), and at the lower

end thereof they are provided with essentially radially projecting portions (37, 38, 61, 62), portions (61, 62) of rods (30) associated with needle-carrier rods (3) being offset relative to portions (37, 38) of rods (30) associated with piercer-carrier rods (14), there being provided a first drive shaft (46) having a radial arm (47) adapted to engage with one of the projecting portions of the rods (30) associated with piercer-carrier rods (14) to cause the same to simultaneously lower against the bias of resilient means (35) in order to cause uncoupling of all the piercer-carrier rods (14) relative to the drive bar (6), and in addition a second drive shaft (63) provided with a radially projecting arm (64) adapted to come into engagement with one of the projecting portions of the rods (30) associated with needle-carrier rods (3) to cause them to lower in order to cause uncoupling of all the needle-carrier rods (3) relative to the drive bar (6), there being also provided means, for each of the rods (30), to keep the same in said lowered position thereof, and which engage respectively with a second projecting portion (62) of the rods (30) associated with needle-carrier rods (3) and with a second projecting portion (37) of the rods (30) associated with piercer-carrier rods (14).

2. Device according to Claim 1, characterized in that, said first drive shaft (46) extends along all the width of the embroidery machine, and radial arm (47) associated therewith also extends along all the width mentioned above, coming into engagement with all the projections (38) of rods (30) associated with piercer-carrier rods (14), said projecting portions being provided on one side of rods (30) at the lower end thereof.

3. Device according to Claim 1, characterized in that, said second drive shaft (63) extends all the way through the width of the embroidery machine on the side of rods (30) opposite to that where the first drive shaft (46) is provided, radial arm (64) associated with said second drive shaft extending too along all said length, and being adapted to come into engagement with all the projecting portions (61) of rods (30) associated with needle-carrier rods (3), which are provided on the opposite side of rods (30) compared to the side where projections (38) are provided, and at a higher height than the latter.

4. Device according to Claim 1, characterized in that the means keeping rods (30) temporarily in the lowered position include, for each of said rods (30) electromagnet means (53) whose moving element (56) comes into engagement with vertical side (51) of a plate (48) pivoted to the machine frame, each of said vertical sides (51) of plate (48) being adapted to engage with a projecting portion (37) of a rod (30) associated with a piercer-carrier rod (14) and with a projecting portion (62) of a rod (30) associated with a needle-carrier rod (3).

5. Device according to Claim 4, characterized in that the moving element (56) of each electromagnet means (53) includes a rod having a substantially fork-shaped end (57) thereof and provided with a transverse pin (58), vertical side (51) of plate (48) being adapted to engage alterna-

tively with said pin (58) or with the bottom (59) of the forked end of rod (56), respectively for disengagement or engagement of said vertical side (51) of plate (48) with projecting portions (37, 62) of rods (30) associated with piercer-carrier rods (14) and with needle-carrier rods (3).

6. Device according to Claim 1, characterized in that each plate (48) is substantially L-shaped being therefore provided with a substantially horizontal side (52) adapted to engage with a further rod (65) of lower height than rods (30), thus enabling plate (48) to disengage from said projecting portions (37, 62) of rods (30).

7. Device according to Claim 6, characterized in that thin rods (65) extend parallel to rods (30) and are slidable in the machine frame against the action of resilient means (67) to come into engagement with horizontal side (52) of plates (48), a stop member (70) being provided to limit the displacement caused by said resilient means (67).

8. Device according to Claim 1, characterized in that piercers (13) are carried by a substantially L-shaped square connecting bracket (15), which is in turn fastened to the end of a piercer-carrier rod (14).

9. Device according to Claim 8, characterized in that said square connecting member (15) has a vertical side at the upper end of which is fastened the end of piercer carrier rod (14), and a horizontal side having piercer (13) fastened to the free end thereof, the piercer therefore being located vertically underneath a needle (1).

10. Device according to Claim 8, characterized in that on the corner of square member (15) there is fastened the end of a rod (19) slidably engaged in cross member (5) wherein needle-carrier rods (3) and piercer-carrier rods (14) can slide, said rod (19) being adapted to inhibit rotations of square member (15) about an axis parallel to the direction of motion of piercer-carrier rod (14).

11. Device for enabling and disabling needle-carrier rods and piercer-carrier rods including, for each of said rods, a pivoting control arm (9) cooperating with a connecting pin (10) to couple needle-carrier rod or piercer-carrier rod to the only drive bar (6), characterized in that said oscillating control arms and connecting pins (10) are all in the same plane.

12. Embroidery machine, in particular shuttle operated machine, provided with the device according to Claims 1 to 11.

Patentansprüche

1. Freigabe- und Sperreinrichtung für Nadelträgerstäbe und Stecherträgerstäbe gemäß einem voreinstellbaren Programm, insbesondere in einer Schiffchenstickmaschine, umfassend Mittel zur Kupplung und Entkupplung dieser Stäbe in bezug auf eine Antriebsstange, die so ausgelegt ist, daß sie diesen eine Oszillationsbewegung vermittelt, und Steuermittel dieser Mittel zur Kupplung und Entkupplung der Nadelträgerstäbe und Stecherträgerstäbe in bezug auf die Antriebs-

stange, dadurch gekennzeichnet, daß die Steuer-
mittel ein hinter und quer zu den Nadelträgerstä-
ben (3) und Stecherträgerstäben (14) ange-
ordnetes System aus beweglichen Stäben (30)
inkludiert, die jeweils in ihrem oberen Teil mit
einem Steuerhebel (25) verbunden sind, der mit
den Mitteln zum Freigeben und Sperren der Nadel-
trägerstäbe (3) und Stecherträgerstäbe (14)
zusammenwirkt, und die an ihrem unteren Ende
mit im wesentlichen radial abstehenden Teilen
(37, 38, 61, 62) versehen sind, wobei die den
Nadelträgerstäben (3) zugeordneten Teile (61, 62)
der Stäbe (30) in bezug auf die den Stecherträger-
stäben (14) zugeordneten Abschnitte (37, 38) der
Stäbe (30) versetzt sind, wobei eine erste Antriebs-
welle (46) vorgesehen ist, die einen radialen Arm
(47) aufweist, der mit einem der abstehenden Teile
der den Stecherträgerstäben (14) zugeordneten
Stäbe (30) in Eingriff bringbar ist, um zu bewirken,
daß sich dieser gleichzeitig gegen die Vorspan-
nung eines Federmittels (35) senkt, um eine Ent-
kupplung aller Stecherträgerstäbe (14) in bezug
auf die Antriebsstange (6) zu bewirken, und zusätz-
lich eine zweite Antriebswelle (63) mit einem radial
abstehenden Arm (64) mit einem der abstehenden
Teile der den Nadelträgerstäben (3) zugeordneten
Stäbe (30) in Eingriff bringbar ist, um zu bewirken,
daß sie sich senken, um eine Entkupplung aller
Nadelträgerstäbe (3) in bezug auf die Antriebs-
stange (6) zu bewirken, wobei auch Mittel zum
Halten jedes Stabes (30) in abgesenkter Position
vorgesehen sind, welche jeweils mit einem zwei-
ten abstehenden Teil (62) der den Nadelträgerstä-
ben (3) zugeordneten Stäbe (30) und mit einem
zweiten Abschnitt (37) der den Stecherträgerstä-
ben (14) zugeordneten Stäbe (30) eingreifen.

2. Vorrichtung nach Anspruch 1, dadurch
gekennzeichnet, daß sich die erste Antriebswelle
(46) über die gesamte Breite der Stickmaschine
erstreckt und sich ein dieser zugeordneter radialer
Arm (47) ebenfalls über die gesamte oben
erwähnte Breite erstreckt und mit allen Fortsätzen
(38) der den Stecherträgerstäben (14) zugeordne-
ten Stäbe (30) in Eingriff kommt, wobei die abste-
henden Teile an einer Seite der Stäbe (30) an deren
unterem Ende vorgesehen sind.

3. Vorrichtung nach Anspruch 1, dadurch
gekennzeichnet, daß sich die zweite Antriebswelle
(63) über die gesamte Breite der Stickmaschine an
der Seite der Stäbe (30) gegenüber jener Seite, an
welcher die erste Antriebswelle (46) vorgesehen
ist, erstreckt, wobei sich ein zur zweiten Antriebs-
welle zugehöriger radialer Arm (64) ebenfalls über
die gesamte Länge erstreckt und so ausgelegt ist,
daß er mit allen abstehenden Teilen (61) der den
Nadelträgerstäben (3) zugeordneten Stäbe (30) in
Eingriff kommt, die bezüglich der Seite, auf
welcher die Fortsätze (38) vorgesehen sind, auf der
gegenüberliegenden Seite der Stäbe (30) und
höher als die letzteren angeordnet sind.

4. Vorrichtung nach Anspruch 1, dadurch
gekennzeichnet, daß die Mittel, die die Stäbe (30)
vorübergehend in der abgesenkten Position hal-
ten, für jeden der Stäbe (30) elektromagnetische
Mittel (53) inkludieren, deren bewegliches Ele-

ment (56) mit der vertikalen Seite (51) einer am
Maschinenrahmen schwenkbar befestigten Platte
(48) in Eingriff gelangt, wobei jede der vertikalen
Seiten (51) der Platte (48) mit einem abstehenden
Teil (37) eines dem Stecherträgerstab (14) zuge-
ordneten Stabes (30) und mit einem abstehenden
Teil (62) eines einem Nadelträgerstab (3) zugeord-
neten Stabes (30) in Eingriff bringbar ist.

5. Vorrichtung nach Anspruch 4, dadurch
gekennzeichnet, daß das bewegliche Element (56)
jedes elektromagnetischen Mittels (53) einen Stab
mit einem im wesentlichen gabelförmigen Ende
(57) inkludiert, der mit einem Querstift (58) ver-
sehen ist, wobei die vertikale Seite (51) der Platte (48)
so ausgelegt ist, daß sie alternativ mit dem Stift
(58) oder mit dem Boden (59) des gegabelten
Endes des Stabes (56) in Eingriff ist zwecks Lösens
bzw. Eingriffs der vertikalen Seite (51) der Platte
(48) von bzw. mit den abstehenden Teilen (37, 62)
der den Stecherträgerstäben (14) und den Nadel-
trägerstäben (3) zugeordneten Stäbe (30).

6. Vorrichtung nach Anspruch 1, dadurch
gekennzeichnet, daß jede Platte (48) im wesent-
lichen L-förmig ist und daher mit einer im wesent-
lichen horizontalen Seite (52) versehen ist, die mit
einem weiteren Stab (65) von geringerer Höhe als
die Stäbe (30) in Eingriff bringbar ist, wodurch die
Platte (48) von den abstehenden Teilen (37, 62) der
Stäbe (30) außer Eingriff gebracht werden kann.

7. Vorrichtung nach Anspruch 6, dadurch
gekennzeichnet, daß sich dünne Stäbe (65) parallel
zu den Stäben (30) erstrecken und in einem
Maschinenrahmen gegen die Wirkung eines
Federmittels (67) gleitbar sind, um mit der horizon-
talen Seite (52) der Platten (48) in Eingriff zu
gelangen, wobei ein Anschlagelement (70) vorge-
sehen ist, um die durch die Federmittel (67)
bewirkte Verschiebung zu begrenzen.

8. Vorrichtung nach Anspruch 1, dadurch
gekennzeichnet, daß die Stecher (13) von einer im
wesentlichen L-förmigen, rechtwinkligen Verbind-
ungsglasche (15) getragen werden, die wiederum
am Ende eines Stecherträgerstabes (14) befestigt
ist.

9. Vorrichtung nach Anspruch 8, dadurch
gekennzeichnet, daß das rechtwinklige Verbind-
ungselement (15) eine vertikale Seite hat, an
deren oberem Ende das Ende des Stecherträger-
stabes (14) befestigt ist, und eine horizontale Seite,
an deren freiem Ende der Stecher (13) befestigt ist,
weshalb der Stecher vertikal unterhalb einer Nadel
(1) angeordnet ist.

10. Vorrichtung nach Anspruch 8, dadurch
gekennzeichnet, daß an der Ecke des rechtwinkli-
gen Elements (15) das Ende eines Stabes (19)
befestigt ist, der gleitbar in einem Querelement (5)
in Eingriff gehalten ist, in welchem die Nadelträ-
gerstäbe (3) und die Stecherträgerstäbe (14) glei-
ten können, wobei der Stab (19) so ausgelegt ist,
daß er Drehungen des rechtwinkligen Elements
(15) um eine Achse parallel zur Bewegungsrich-
tung des Stecherträgerstabes (14) hemmt.

11. Vorrichtung zur Freigabe und Sperrung von
Nadelträgerstäben und Stecherträgerstäben,
umfassend für jeden dieser Stäbe einen Schwenk-

steuerarm (9), der mit einem Verbindungsstift (10) zusammenwirkt, um den Nadelträgerstab oder den Stecherträgerstab mit der einzigen Antriebsstange (6) zu kuppeln, dadurch gekennzeichnet, daß diese oszillierenden Steuerarme und Verbindungsstifte (10) alle in derselben Ebene liegen.

12. Stickmaschine, insbesondere Schiffchenstickmaschine, die mit einer Vorrichtung nach dem Ansprüchen 1 bis 11 versehen ist.

Revendications

1. Mécanisme pour la sélection de barres porte-aiguille et de barres porte-poinçon selon un programme qui peut être préétabli, en particulier dans une machine à broder à navette, lequel comprend des moyens pour engager et dégager lesdites barres d'une barre de commande apte à donner auxdites barres un mouvement rectiligne alternatif et des moyens de commande des susdits moyens pour engager et dégager les barres porte-aiguille et les barres porte-poinçon de la barre de commande, caractérisé en ce que lesdits moyens de commande comprennent un ensemble de tiges mobiles (30) lesquelles sont disposées à l'arrière et transversalement auxdites barres porte-aiguille (3) et auxdites barres porte-poinçon (14) et sont reliées chacune supérieurement à un levier de commande (25) qui coopère avec lesdits moyens pour engager et dégager les barres porte-aiguille (3) et les barres porte-poinçon (14) et à leur extrémité inférieure sont pourvues des parties (37, 38, 61, 62) saillantes essentiellement d'une façon radiale, les parties (61, 62) des tiges (30) associées aux barres porte-aiguille (3) étant décalées par rapport aux parties (37, 38) des tiges (30) associées aux barres porte-poinçon (14) étant prévu un premier arbre de commande (46) pourvu d'un bras radial (47) lequel est apte à s'engager avec une des parties saillantes des tiges (30) associées aux barres porte-poinçon (14) pour commander leur abaissement simultané contre l'action de moyens élastiques (35) pour provoquer le dégagement de toutes les barres porte-poinçon (14) de la barre de commande (6), ainsi qu'un second arbre de commande (63) pourvu d'un bras saillant d'une façon radial (64) apte à s'engager avec une des parties saillantes des tiges (30) associées aux barres porte-aiguille (3) pour en causer l'abaissement dans le but de causer le dégagement de toutes les barres porte-aiguille (3) de la barre de commande (6), étant enfin prévus, pour chacune des tiges (30), des moyens pour les maintenir dans ladite position abaissée lesquels s'engagent respectivement avec une seconde partie saillante (62) des tiges (30) associées aux barres porte-aiguille (3) et avec une seconde partie saillante (37) des tiges (30) associées aux barres porte-poinçon (14).

2. Mécanisme selon la revendication 1, caractérisé en ce que ledit premier arbre de commande (46) s'étend pour toute la largeur de la machine à broder et le bras radial (47) qui lui est associé s'étend également pour toute la longueur susdite en s'engageant avec toutes les parties saillantes

(38) des tiges (30) associées aux barres porte-poinçon (14) lesquelles sont prévues sur un côté des tiges (30) à leur extrémité inférieure.

3. Mécanisme selon la revendication 1, caractérisé en ce que ledit second arbre de commande (63) s'étend pour toute la largeur de la machine à broder sur le côté des tiges (30) opposé à celui où est prévu le premier arbre de commande (46), le bras radial (64) associé audit second arbre de commande s'étendant également pour toute la susdite longueur et étant apte à s'engager avec toutes les parties saillantes (61) des tiges (30) associées aux barres porte-aiguille (3) lesquelles sont prévues sur le côté des tiges (30) opposé à celui où sont prévues les saillies (38) et à une hauteur plus grande que ces dernières.

4. Mécanisme selon la revendication 1, caractérisé en ce que les moyens pour maintenir les tiges (30) temporairement dans la position abaissée comprennent, pour chacune desdites tiges (30), des moyens à électroaimant (53) l'équipage mobile (56) desquels s'engage avec le côté vertical (51) d'une plaquette (48) pivotant sur le cadre de la machine, chacun desdits côtés verticaux (51) des plaquettes (48) étant apte à s'engager avec une partie saillante (37) d'une tige (30) associée à une barre porte-poinçon (14) et avec une partie saillante (62) d'une tige (30) associée à une barre porte-aiguille (3).

5. Mécanisme selon la revendication 4, caractérisé en ce que l'équipage mobile (56) de chacun moyen à électro-aimant (53) comprend une tige ayant une extrémité (57) façonnée essentiellement à fourche et pourvue d'un pivot transversal (58), le côté vertical (51) de la plaquette (48) étant apte à s'engager alternativement avec le susdit pivot (58) ou avec le fond (59) de l'extrémité à fourche de la tige (56) respectivement pour le dégagement et l'engagement dudit côté vertical (51) de la plaquette (48) avec les parties saillantes (37, 62) des tiges (30) associées aux barres porte-poinçon (14) et aux barres porte-aiguille (3).

6. Mécanisme selon la revendication 4, caractérisé en ce que chacune plaquette (48) est façonnée essentiellement à L et elle présente par conséquent un côté essentiellement horizontal (52) apte à s'engager avec une ultérieure tige (65) ayant une hauteur inférieure à celle des tiges (30) laquelle permet le dégagement de la plaquette (48) des parties saillantes (37, 62) des tiges (30).

7. Mécanisme selon la revendication 6, caractérisé en ce que les tiges (65) s'étendent parallèlement aux tiges (30) et elles sont coulissantes dans le cadre de la machine contre l'action de moyens élastiques (67) pour s'engager avec le côté horizontal (52) des plaquettes (48), étant prévu un élément de fin de course (70) apte à limiter le déplacement provoqué par lesdits moyens élastiques (67).

8. Mécanisme selon la revendication 1, caractérisé en ce que les poinçons (13) sont portés par un élément angulaire de liaison (15) façonné essentiellement à L lequel est à son tour solidaire de l'extrémité de la barre porte-poinçon (14).

9. Mécanisme selon la revendication 8, caracté-

risé en ce que ledit élément angulaire de liaison (15) présente un côté vertical à l'extrémité supérieure duquel est fixé l'extrémité de la barre porte-poinçon (14), ainsi qu'un côté horizontal à l'extrémité libre duquel est fixé le poinçon (13) qui se trouve par conséquent perpendiculairement au-dessous d'une aiguille (1).

10. Mécanisme selon la revendication 8, caractérisé en ce que sur le sommet de l'élément angulaire (15) est fixée l'extrémité d'une tige (19) laquelle est coulissante dans la traverse (5) dans laquelle coulisent les barres porte-aiguille (3) et les barres porte-poinçon (14), cette tige (19) étant apte à empêcher rotations de l'élément angulaire (15) autour d'un axe paral-

lèle à la direction de mouvement de la barre porte-poinçon (14).

11. Mécanisme pour la sélection de barres porte-aiguille et de barres porte-poinçon, comprenant, pour chacune de ces barres, un bras de commande pouvant osciller (9) lequel coopère avec un pivot de liaison (10) pour relier la barre porte-aiguille et la barre porte-poinçon à l'unique barre de commande (6), caractérisé en ce que les susdits bras de commande pouvant osciller et les pivots de liaison (10) sont situés tous dans un même plan.

12. Machine à broder, en particulier à navette, pourvue du mécanisme selon les revendications de 1 à 11.

5

10

15

20

25

30

35

40

45

50

55

60

65

14

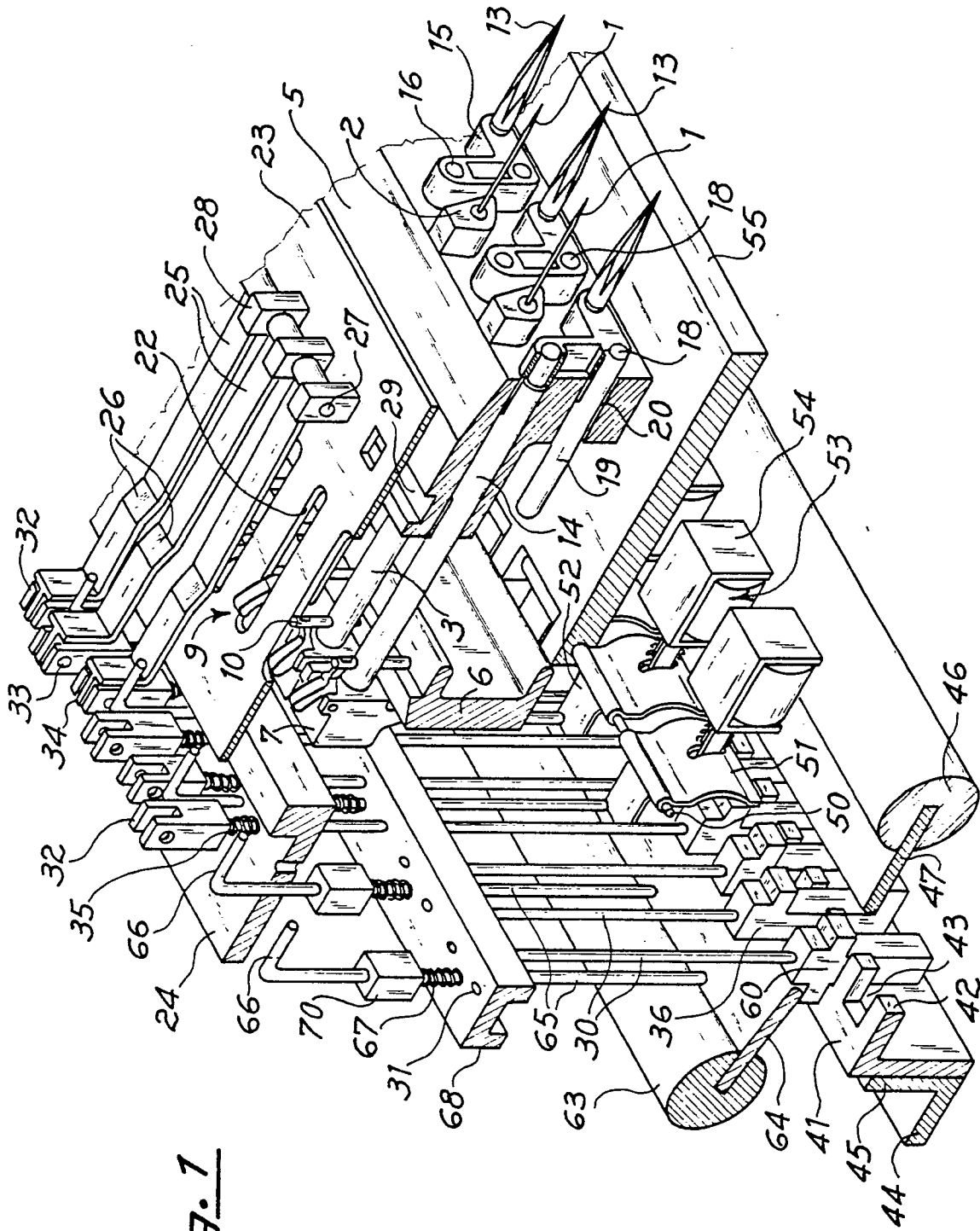

Fig. 1

