



(12)

EUROPEAN PATENT APPLICATION

(21) Application number: 86309371.2

(51) Int. Cl.4: **B07C 5/34**

(22) Date of filing: 02.12.86

(30) Priority: 30.12.85 US 814853

(43) Date of publication of application:
02.09.87 Bulletin 87/36

(84) Designated Contracting States:
DE FR GB IT

(71) Applicant: **EMHART INDUSTRIES, INC.**
426 Colt Highway
Farmington Connecticut 06032(US)

(72) Inventor: **Williams, Reade**
96 Blueberry Lane
South Hamilton Massachusetts 01982(US)
Inventor: **Scott, Paul Frederick**
19 Capitol Avenue
Hartford Connecticut 06106(US)

(74) Representative: **Drury, Peter Lawrence et al**
Emhart Patents Department P.O. Box 88
Ross Walk
Belgrave Leicester LE4 5BX(GB)

(54) **Mold identification.**

(57) A mold number reader for detecting code marks (15) at the heel of a transparent bottle or the like, such code marks desirable being in the form of dots or balls protruding from the bottle's heel. During rotation of the bottle, its heel portion is illuminated with a structured collimated light beam (40) in the form of a narrow rectangle, which light is selectively reflected by code marks and collected by field-type optics (60, 65). The use of a well defined collimated light source of small area provides a high input signal level, while the field optics enjoys a high depth of field and hence decreased sensitivity to bottle placement during inspection. The light source may be a modulated laser diode (25) and the signal processing electronics may include a demodulator - (120) to process the photodetector (70) output signal. The use of heterodyned signal processing decreases the sensitivity to ambient light and other sources of noise in the output signal.

FIG. 1

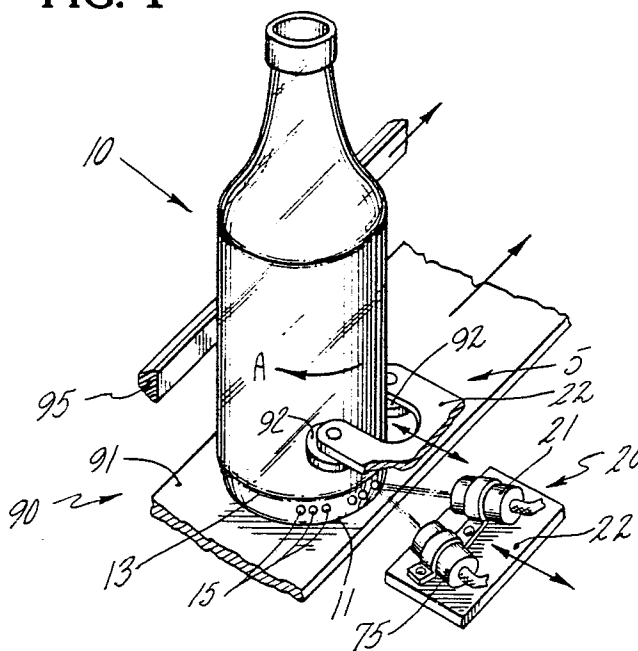

EP 0 234 105 A1

MOLD IDENTIFICATION

Background of the Invention

The present invention relates to the identification of a mold with a glass container or like molded article, and more particularly to the design of reliable inspection apparatus, suited to detecting "dot codes".

In the manufacture of glass containers and like articles in a press mold, casting mold, or blow mold, any malformations of the mold are transferred onto the article. It is necessary in such applications to identify the mold in which a specific defective article has been produced and sort out all articles made in this mold. This need has been particularly acute in the high speed production of glass containers, in which the molds are subjected to destructive thermal and mechanical influences. The generally accepted approach to this problem has been to furnish each mold with a marking, to be transferred onto all articles molded thereby.

A variety of mold identification code markings have been adopted, among the most popular of which is the dot-code; the present invention is especially applicable to the accurate detection of this type of code. Typical of the prior approaches to mold number reading is the system of commonly assigned U.S. Patent No. 4,201,338. In the '338 system and similar prior art mold number readers, a light source illuminates an area of the bottle's heel large enough to account for variations of bottle shape, relative placement of the photodetector, and other geometric factors. Light which has been reflected from a dot-code marking on the bottle is focused into the photodetector using a imaging-type optical system, and processed to extract the mold identification information. Such systems do not clearly discriminate between background light and the light produced by the code marking, and require elaborate filtering to minimize this problem. More significantly, such systems have a quite limited depth of field, and hence are very sensitive to variations in bottle motion and other disturbances.

Accordingly, it is a principal object of the invention to provide improved method and apparatus for identifying code markings on glass containers and other articles. As a related object, such apparatus should enjoy reliable performance under high speed operating conditions.

Another object is to provide a durable system which is easily adapted to a variety of operating environments.

A further object is to achieve a high degree of accuracy in the face of possible sources of "noise" in the output signals of such apparatus. These devices should enjoy increased immunity to background light and other spurious signal sources.

Summary of the Invention

The above and additional objects are successfully realized by the mold identification apparatus and method of the invention, in which the pattern of protruding mold code marks in a predetermined sector of a molded vessel is detected using a field optics assembly. The article sector containing an array of protruding mold code marks is illuminated with a substantially collimated light beam of limited cross section. This light beam creates a well defined area of illumination of high luminance in the mold code sector, which illumination is selectively reflected. In the absence of a mold code mark, the light is reflected away from the field optics assembly, while a mold code mark if present reflects a detectable portion of the light to the field optics assembly. Thus, a detectable light input to the field optics assembly provides a reliable indication that a code mark is present. In the preferred embodiment of the invention, the mold code marks are essentially hemispherical "dot codes".

One aspect of the invention is the nature of the code mark illumination. Most preferably, for detecting dot codes, the area of illumination is a narrow rectangle of substantially greater vertical dimension than the code mark diameter, but somewhat narrower than such diameter. Thus, when scanning a vessel for dot codes, the illumination will at any given time be distinctly associated with at most a single code mark, as the direction of scanning is transverse to the long axis of the illuminated area. Due to the high luminance of such illumination, a clearly detectable signal will arise in the presence of a code mark.

Another aspect of the invention is the nature of the field optics assembly. This assembly captures light within a "zone of acceptance", which in the preferred embodiment is conical. Advantageously, this assembly includes an objective lens which defines the zone of acceptance, and a field lens which focuses light onto a photodetector. The photodetector provides a light energy signal representative of the amount of light collected by the field optics assembly. The variations over time of the photodetector output signal while scanning the mold code sector provides a reliable indication of the code mark pattern.

In the preferred embodiment of the invention, the light source provides a light energy output modulated at a high frequency, and the photodetector output is demodulated to extract the signal at the modulation frequency. This heterodyned signal technique reduces the output signal noise due to background light and other sources.

Brief Description of the Drawings

The above and additional aspects of the invention are illustrated in the following detailed description of the preferred embodiment, which is to be taken together with the drawings in which:

Figure 1 is a fragmentary perspective view of mold identification apparatus in accordance with preferred embodiment of the invention;

Figure 2 is an optical schematic diagram of the mold identification apparatus of Figure 1, viewed from below;

Figure 3 is an optical schematic diagram of the apparatus of Figure 1, viewed along an axial container section not containing a code marking;

Figure 4 is an optical schematic diagram of the apparatus of Figure 1, viewed along an axial container section containing a code marking;

Figure 5 is a block schematic diagram of an electronic driver-signal processing circuit for the apparatus of Figure 1; and

Figure 6 is a partial elevation view of a container undergoing inspection by the apparatus of Figure 1.

Detailed Description

Reference should now be had to Figures 1-6 for a detailed description of a preferred mold identification device embodying the invention. Figure 1 gives a fragmentary perspective view of a mold identification system 5, including bottle handling apparatus 90 and code reader assembly 20. The bottle handling apparatus 90 is designed to stop a glass container 10 at the inspection station and rotate it to present to the code reader system 20 an array of code markings 15 near the container's heel. Illustratively, the bottle handling devices 90 include underlying conveyor 91 as well as side belt 95 and spring loaded rollers 92. When container 10 has arrived at the inspection station, rollers 93 press the container against side belt 95 for rotation through at least one container circumference.

In the illustrated embodiment, the code reader assembly 20 includes a movable base 22 carrying a light source assembly 21 and photodetector assembly 75. Base 22 moves in conjunction with rollers 92 toward container 10 to bring assemblies 21 and 75 into a suitable position for inspection, as further discussed below.

As may best be seen in the elevation view of Figure 6, container 10 includes a circumferential array of code marks 15 located in a sector 13 just above the bottle's heel 11. Each of code marks 15 illustratively comprises an essentially hemispherical protrusion from the container's side wall. In the present invention, the light source assembly 21 provides a small, well defined illuminated area 45. Preferably, the illuminated area 45 takes the form of a narrow rectangle with its long sides of length L essentially parallel to the axis of symmetry of container 10 (i.e., vertical axis), such illuminated area extending well above and below the height of code marks 15. The width W of illuminated zone 40 is advantageously somewhat narrower than the diameter of code markings 15. It will be seen that the area of illumination is quite limited in comparison with those of typical prior art "imaging-type" mold identification systems. The illumination of code markings 45 with a narrow, well-defined light pattern of high luminance, provides clear, distinct identification of each of the dot-code markings 15 of a given mold code pattern.

Having reference to the optical diagram of Figure 2, which views the code reader optics 20 and bottle 10 from below, the light source 25 advantageously consists of a laser diode. In a given operative embodiment, light source 25 consisted of a Mitsubishi ML4102 or ML4402 laser diode, operating in fundamental transverse mode, with a limited astigmatism of around 4 micrometers (ML4102 and ML4402 are tradenames of Mitsubishi Electric Corporation). This laser diode provides essentially a point source of near-infrared light with fan-out characteristics which depend on orientation relative to the junction diode. Light emitted from laser diode 25 passes through plano-cylindrical lenses 30 and 35, which are perpendicularly oriented (compare figures 2 and 3). Advantageously, lens 30 is separated from the junction of laser diode 25 by one focal length. Lenses 30 and 35 limit the divergence of light rays 41, 43 from the central axis 42 in the horizontal and vertical planes, respectively. Thus, this lens system focuses the laser light to form a collimated beam 40 of high luminance and limited cross section.

When the illuminated area 45 encompasses a given code mark 15, light will be reflected over a zone of reflection 58 of angle \emptyset in the horizontal plane. This zone of reflection is defined by the reflected rays 41a, 43a, arising from the extreme

incident rays 41, 43. Objective lens 60 subtends a fixed portion of the zone reflection—in the preferred embodiment, a conical "zone of acceptance"—over which the reflected light will be captured. The extent of this zone of acceptance determines the lateral field of view over which code markings 15 will be detected. Illustratively, lens 60 is a plano-convex spherical lens. Lens 60 converges the captured light to field lens 65, which in turn focuses the light onto photodetector 70. In an operative embodiment of the invention, photodetector 70 comprises a PIN photodiode, 508204200 series, of Hewlett Packard Corporation.

Figures 3 and 4, both taken along on axial plane of container 10, illustrate the difference in reflection of the incident light 40 depending on whether a code mark 15 is present or absent. In figure 3, with no code mark present, light will be reflected by the inclined container surface 13 generally downwardly within a zone of reflection 59 of angle α defined by boundaries 81a, 82a. Inasmuch as this zone of reflection 59 does not encompass the lens 60, none of this light will be captured by the field optics. As seen in figure 4, if a code marking 15 is present, however, a portion 50 of the light reflected by mark 15 will be directed to lens 50 and captured by the field optics assembly. In the preferred embodiment of dot-code identification, in which code marking 15 is essentially hemispherical, it will reflect the incident light over a broad, continuous zone (a "line out" pattern).

Referring again to Figure 2, the light source assembly 21 and photodetector assembly 75 are each aligned at an angle θ relative to the center line 47. Smaller values of θ provide higher depths of field, but require more compact packaging and mounting of the components of assemblies 21, 75 - (Figure 1). It is a principal advantage of the present invention that the use of field optics in the photodetector 75 provides depths of field which are far superior to prior art, "imaging" systems.

Figure 5 schematically illustrates a preferred heterodyned, design of electronics 100 for driving laser diode 25 and for processing the output of photodiode 70. Laser diode 25 is driven by a square wave, current controlled oscillator driver 170. Modulating the light source 25 at a high frequency distinguishes the reflected light detected by photodiode 70 from ambient light. Thus, the photodiode output is amplified at 110, demodulated at 120, reamplified at 130, and passed through a modulation frequency filter 140 to extract the radiometric signal representing the light reflected by a code marking 15. This is compared with a preset threshold by comparator 150 to determine whether a significant signal is present, indicating a code mark 15. The comparator output is received by processor 160 to derive the identification code

information. Electronics 100 produces a series of signal peaks representing the individual marks 15 of the dot-code pattern, and interprets these using a suitable decoding algorithm.

As an alternative to the use of a modulator/demodulator system to reduce the effects of background light, the light source optics 21 may include an optical filter which is spectrally matched to the laser diode 25. This technique takes advantage of the fact that laser diode 25 emits light with a very narrow bandwidth.

While reference has been made above to a specific embodiment, it will be apparent to those skilled in the art that various modifications and alterations may be made thereto without departing from the spirit of the present invention. Therefore, it is intended that the scope of this invention be ascertained by reference to the following claims.

Claims

1. A method of identifying a mold in which a vessel has been molded, such vessel being provided with protruding code marks (15) disposed at a sector on an outer surface of the vessel, said method comprising the steps of:

rotating the vessel;

illuminating the sector with a substantially collimated light beam (40) of limited cross section, which light beam is reflected from the vessel; detecting a portion of light reflected from the vessel with a field optics assembly (60, 65) within a zone of acceptance defined by said field optics assembly; and generating code identification signals responsive to the energy of light detected by said field optics assembly, wherein in the absence of a code mark within the path of the beam the vessel reflects relatively little light to the field optics assembly and with the presence of a code mark within the path of the beam, the code mark reflects a detectable amount of light to said field optics assembly.

2. A method as defined in claim 1 for detecting essentially hemispherical code marks, wherein the substantially collimated light beam creates a narrow, essentially rectangular area of illumination at said sector.

3. A method as defined in claim 2, wherein the area of illumination has a length greater than the diameter of the code marks, and a width somewhat less than said diameter, said length being generally vertical.

4. A method as defined in claim 2, wherein the illuminating step comprises illuminating the peripheral zone with a light source periodically varying at a high frequency, and the generating step includes

a step of demodulating (120) a signal representative of the energy of light collected by said field optics assembly.

5. Apparatus for identifying a mold in which a vessel has been molded, said vessel being provided with protruding code marks (15) disposed about a sector on the outer wall of the vessel, comprising:

means including a light source (25) and lens assembly (30, 35) for illuminating the vessel at said sector with a substantially collimated light beam - (40) of limited cross-section, said light beam being reflected from said vessel;

field optics means (60, 65) for collecting a portion of light reflected from said vessel within a zone of acceptance defined by said field optics means; and photodetector means (70) for producing light energy signals representative of the energy of the light collected by said field optics means,

wherein in the absence of a code mark within the path of the beam, the vessel reflects the light beam away from the field optics means, and with the presence of a code mark within the path of the light, the code mark reflects a detectable portion of said light beam to said field optics means.

6. Apparatus as defined in claim 5, wherein the light source comprises a laser diode (25) of near-infrared light and the lens assembly comprises first and second plano cylindrical lenses (30, 35) which are perpendicularly oriented relative to each other to limit the divergence of light in two perpendicular directions.

7. Apparatus as defined in claim 6 for detection of dot codes, wherein the substantially collimated light beam has a narrow, essentially rectangular cross-section with a height greater than the diameter of said dot codes, and a width somewhat less than said diameter.

8. Apparatus as defined in claim 9 wherein the zone of acceptance is essentially conical.

5

10

15

20

25

30

35

40

45

50

55

5

FIG. 1

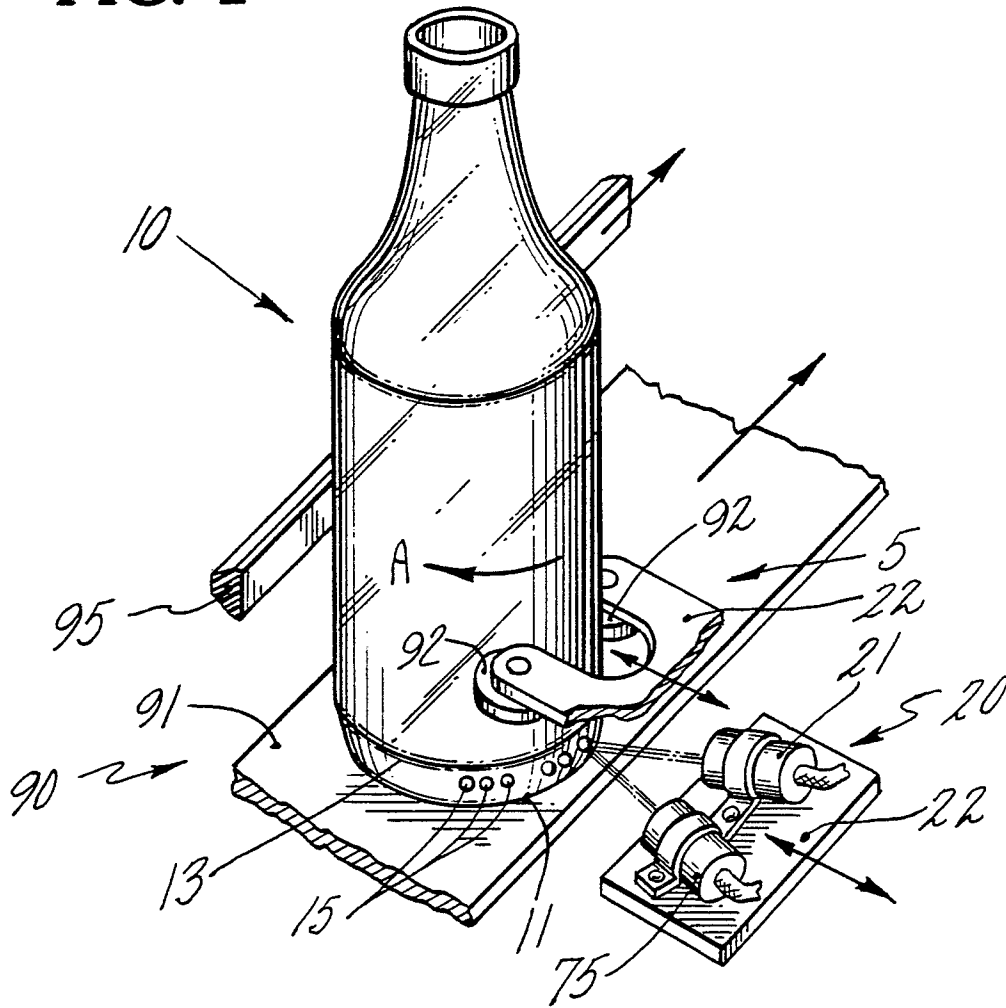

FIG. 6

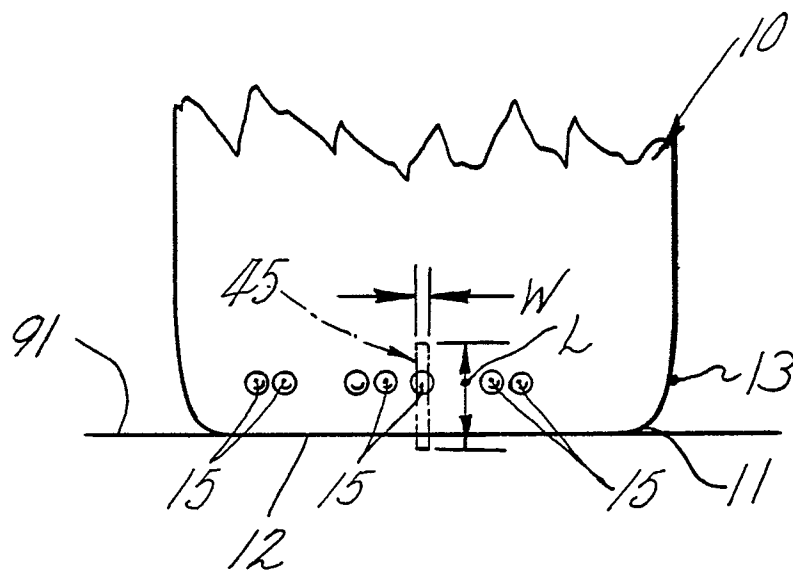
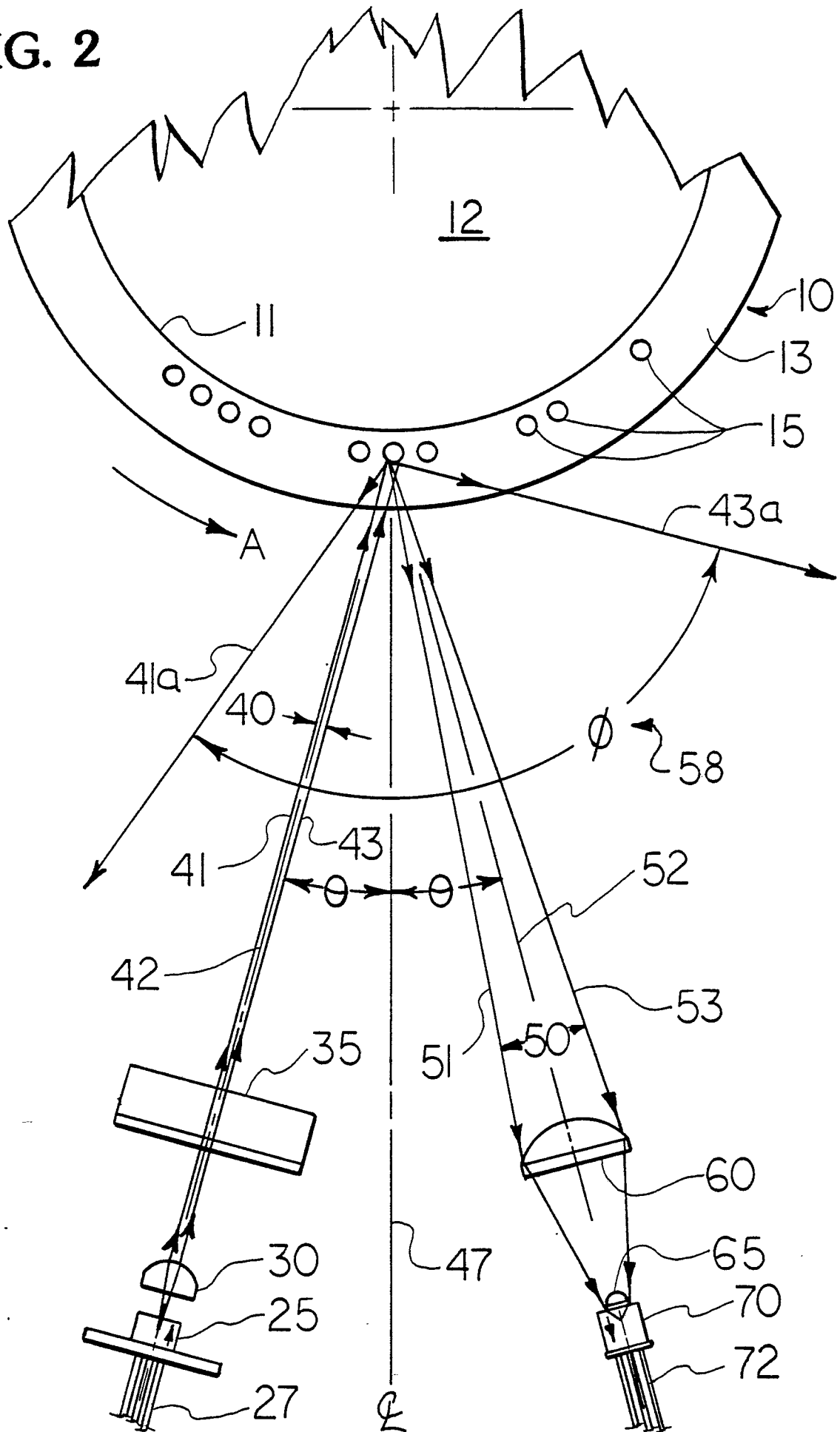
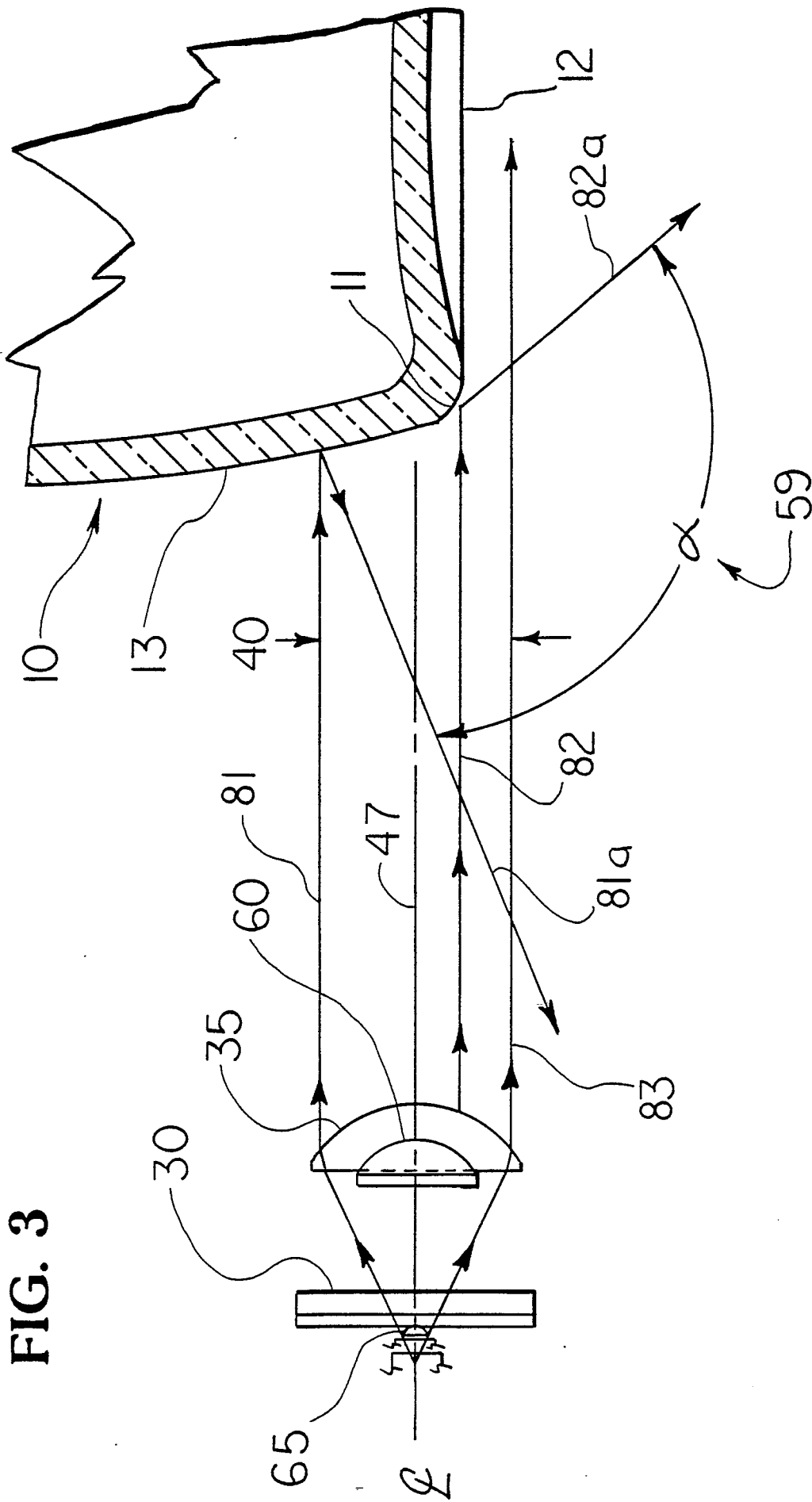

FIG. 2





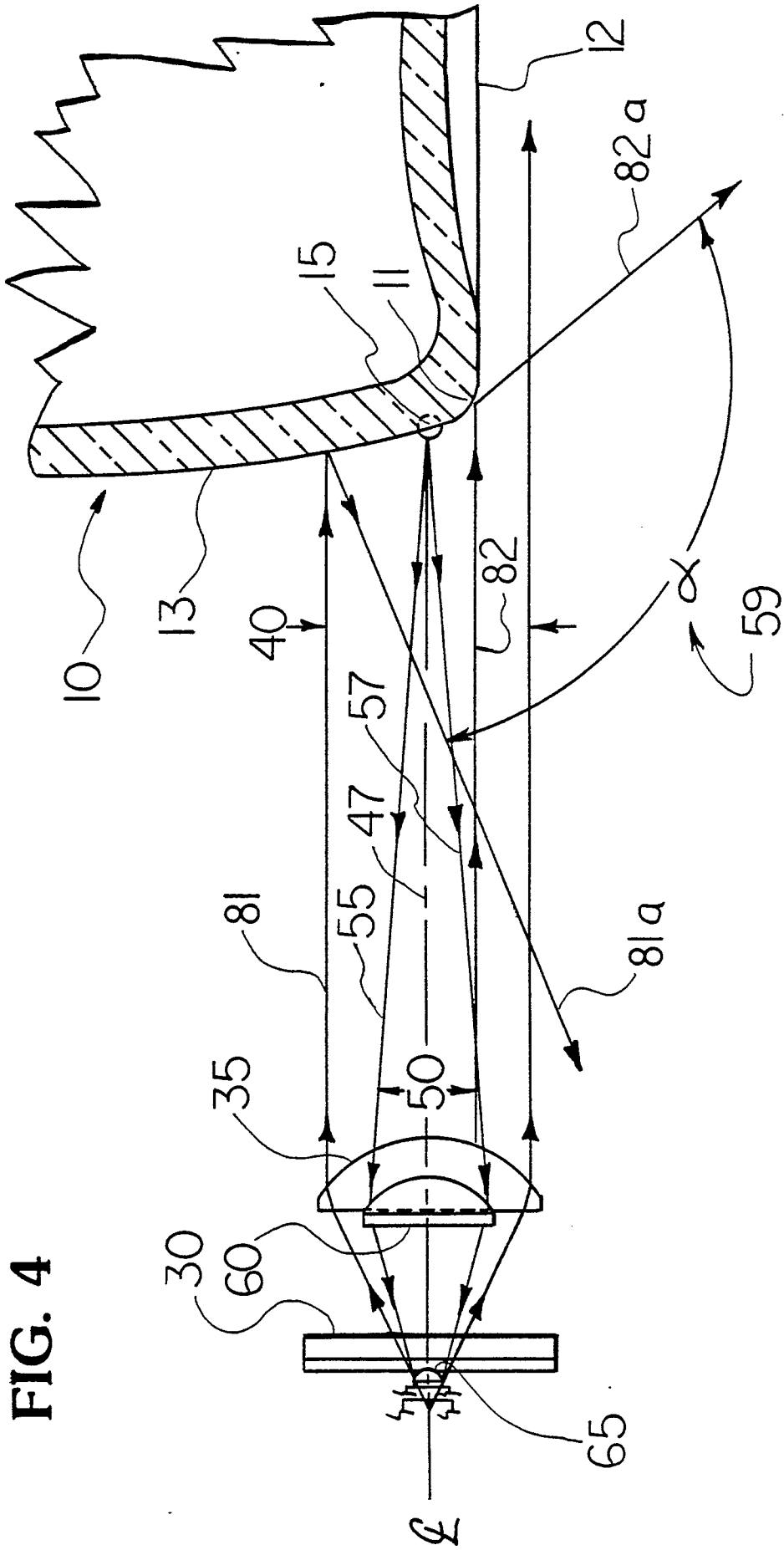
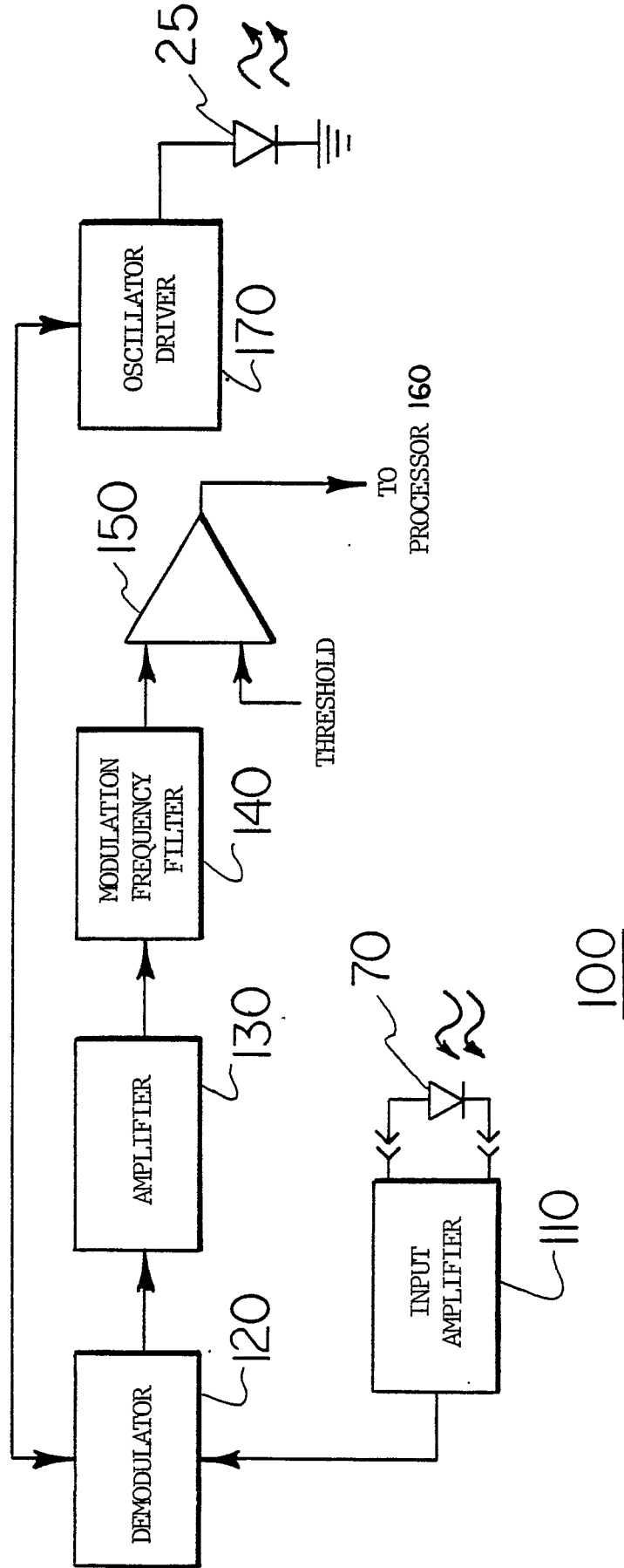

FIG. 4

FIG. 5





DOCUMENTS CONSIDERED TO BE RELEVANT			
Category	Citation of document with indication, where appropriate, of relevant passages	Relevant to claim	CLASSIFICATION OF THE APPLICATION (Int. Cl.4)
X,D	US-A-4 201 338 (KELLER) * Figures 10-12; column 10, line 52 - column 13, line 15 *	1,5	B 07 C 5/34
A	--- ER-A-2 234 613 (AKTIEBOLAGET PLATMANUFAKTUR) * Figure 6; page 8, line 11 - page 9, line 11 * -----	1,5	
			TECHNICAL FIELDS SEARCHED (Int. Cl.4)
			B 07 C G 06 K
The present search report has been drawn up for all claims			
Place of search THE HAGUE		Date of completion of the search 10-04-1987	Examiner GYSEN L.A.D.
CATEGORY OF CITED DOCUMENTS		T : theory or principle underlying the invention E : earlier patent document, but published on, or after the filing date D : document cited in the application L : document cited for other reasons & : member of the same patent family, corresponding document	
X : particularly relevant if taken alone Y : particularly relevant if combined with another document of the same category A : technological background O : non-written disclosure P : intermediate document			