

⑫ **EUROPEAN PATENT SPECIFICATION**

④⑤ Date of publication of the patent specification:  
**17.01.90**

⑤① Int. Cl. 4: **B 66 F 7/22**

②① Application number: **86906341.2**

②② Date of filing: **24.10.86**

⑥⑥ International application number:  
**PCT/FI 86/00120**

⑥⑦ International publication number:  
**WO 87/02974 (21.05.87 Gazette 87/11)**

---

⑤④ **LIFT PLATFORM.**

---

③⑩ Priority: **12.11.85 FI 854449**

⑦③ Proprietor: **ORION-YHTYMÄ OY NORMET**  
**SF-74510 Peltosalmi (FI)**

④③ Date of publication of application:  
**19.11.87 Bulletin 87/47**

⑦② Inventor: **POLOJÄRVI, Raimo Juhani**  
**Salmenranta**  
**SF-74510 Peltosalmi (FI)**

④⑤ Publication of the grant of the patent:  
**17.01.90 Bulletin 90/03**

⑦④ Representative: **Lee, Phillip Graham**  
**MARKS & CLERK 57/60 Lincoln's Inn Fields**  
**London WC2A 3LS (GB)**

⑥④ Designated Contracting States:  
**DE FR GB SE**

⑤⑥ References cited:  
**CH-B-489 383**  
**DE-A-2 224 713**  
**DK-B-141 864**

**EP 0 245 328 B1**

---

Note: Within nine months from the publication of the mention of the grant of the European patent, any person may give notice to the European Patent Office of opposition to the European patent granted. Notice of opposition shall be filed in a written reasoned statement. It shall not be deemed to have been filed until the opposition fee has been paid (Art. 99(1) European patent convention).

## Description

The subject of the present invention is a lift platform, which comprises a working plane, a base, and at least one scissor-like articulation mechanism which connects the working plane and the base with each other, the working plane being arranged displaceable substantially vertically relative to the base by means of the said articulation mechanism and at least one hydraulic lifting cylinder connected to same and also tiltable longitudinally relative to the base.

A lift platform in which a particular scissor-like articulation mechanism is used so as to displace the working plane vertically relative to the base is known in prior art. Ordinarily, such an articulation mechanism comprises beams articulated with each other crosswise in the way of scissors, the lifting force being imparted to the said beams by means of a hydraulic cylinder placed between the articulation point and the base. At one of their ends, the beams are attached to the working plane and to the base conventionally by means of an articulated joint, but at the opposite ends the beams are, as a rule, mounted movably on a horizontal guide in order that a movement of the mechanism should be possible.

Working planes of the type described above are known in prior art, e.g., from the U.S. Patent No. 3 863 793 and from the GB Patent No. 1 354 962. In the said U.S. publication, a device of transportation and installation of ceiling supports for use in mines is described, wherein the lifting mechanism consists of a scissor-like articulation mechanism of the sort described above and of a hydraulic cylinder. The "working plane" of this device is, however, not provided with separate means of tilting, nor can the articulation mechanism as a whole be tilted. The GB Patent No. 1 354 962 describes a cargo handling device used for the loading of aeroplanes, which said device comprises two separate lift platforms provided with scissor-like articulation mechanisms. The said lift platforms are, however, of conventional construction, and none of them is provided with a possibility of tilting. If the above devices of prior-art technology were to be provided with a possibility of tilting, the construction of the devices would have to be modified considerably and, in order to permit tilting of the working plane, the devices would have to be provided with a separate tilting mechanism. This would make the said lift platforms highly complicated and inconvenient in operation.

A lift platform according to the preamble of claim 1 is shown in DE-A-2 224 713, in which the working plane is tiltable (in only one direction) relative to the scissor mechanism, and in CH-B-489 383 and DK-B-141 864, in each of which the scissor mechanism has sliding joints allowing the working plane to tilt (again in only one direction).

In view of eliminating the drawbacks related to the prior-art solutions, the object of the present invention is to provide a lift platform whose working plane is arranged tiltable in two directions. In view

of achieving the objectives stated above and those that will come out in the following, the present invention is characterised in that a first pair of articulated arms of the crosswise pairs of articulated arms of the single or lowermost scissor-like articulation mechanism are attached to the base by a tilting mechanism, by means of which the working plane is tiltable longitudinally relative to the base in both longitudinal directions by tilting the whole scissor-like articulation mechanism.

As compared with the prior-art solution, several advantages are obtained by means of the invention, of which, e.g., the following should be stated. The working plane of the platform in accordance with the invention is arranged tiltable in two directions without a complicated tilting mechanism provided for the working plane. In the solution of the present invention, the entire articulation mechanism of the lift platform is tilted, owing to which a better stability is obtained by means of the device when the base of the lift platform is in a position inclined from the horizontal plane. It is quite a remarkable advantage that tilting of the working plane is possible within the whole range of operation and not only with the working plane raised.

The invention will be described in more detail in the following with reference to the figures in the accompanying drawing.

Figure 1 shows a lift platform in accordance with the invention in its lower position.

Figures 2 and 3 are schematical sectional views of a lift platform in accordance with the invention in the upper position and inclined in different directions.

The main parts of the lift platform in accordance with Figures 1 to 3 are the working plane 1, the base 2, the scissor-like articulated mechanism 3, and the tilting mechanism 4.

In the embodiment shown in the figures, a vehicle frame is used as the base 2, but as a base, it is also possible to use, e.g., a separate auxiliary frame attached to the vehicle frame, a displaceable base provided with wheels or equivalent, or also a stationary, non-mobile base. As to its construction, the scissor-like articulation mechanism 3 is quite a conventional scissor-like articulation mechanism, and it comprises a first pair of articulated arms 31 and a second pair of articulated arms 32, which are articulated with each other crosswise by means of a first articulated joint 33 placed at the middle of the said articulated arms 31 and 32. The first articulated arms 31 are linked by their lower ends to the tilting mechanism 4 by means of a third articulated joint 35, and at the upper end of each first articulated arm 31 a first slide member 12 is mounted, which is fitted so as to run in a first guide 11 provided on the working plane 1.

Correspondingly, each second articulated arm 32 is by its upper end linked to the working plane by means of a second articulated joint 34, and the

lower ends of the second articulated arms 32 are provided with second slide members 22, which are fitted so as to run in horizontal second guides 21 mounted on the base. The said slide members 12 and 22 may have the form of, e.g., a pin, roll, or equivalent, which are fitted to run along the guides 11 and 21. The scissor-like articulated mechanism 3 is further provided with one or several lifting cylinders 36, whose bottom end is attached by means of an articulated joint, either directly or by the intermediate of fastening members, to the first articulated arms 31 within the area between the said first articulated joint 33 and the third articulated joint 35, and which said lifting cylinders 36 are, by the upper end, i.e. by the piston rod, attached by means of an articulated joint, either directly or by the intermediate of fastening members, to the second articulated arms 32 within the area between the said first articulated joint 33 and the second articulated joint 34. As the lifting cylinders 36, it is possible to use single-acting or double-acting hydraulic cylinders, and in the embodiment shown in the figures, the lifting cylinders 36 consist of telescopic cylinders, which provide large lifting height and require little space in the compressed state.

In the embodiment shown in Figs. 1 to 3, it is shown further that there is only one scissor-like articulation mechanism 3 between the working plane 1 and the base 2. It is, however, obvious that in the device it is possible to use several scissor-like articulation mechanisms 3 placed one above the other, linked together in a way in itself known. In such a case, the topmost scissor-like articulation mechanism 3 is attached to the working plane 1 in the way described above, and the lowermost scissor-like articulation mechanism 3 is attached to the base 2 and to the tilting mechanism 4 in the way described above.

The tiltability of the lift platform has been achieved by means of the tilting mechanism 4, which comprises tilting arms 41, which are by one end attached to the base 2 by means of a fourth articulated joint 42 and which said tilting arms 41 are, by the opposite end, attached to the first articulated arms 31 by means of a third articulated joint 35. The tilting arms 41 are arranged pivotable around the said fourth articulated joint 42 by means of tilting cylinders 43, which are by one end attached to the base 2 by means of an articulated joint and, by the opposite end, i.e. by the piston rod, attached to the tilting arms 41 by means of an articulated joint. By shortening and extending the tilting cylinders 43, it is thus possible to pivot the tilting arms 41 around the fourth articulated joint 42, whereby the position of the third articulated joint 35 relative the base 2 is changed, which produces a tilting of the entire scissor-like articulated mechanism 3 and the working plane 1 in the desired direction relative the longitudinal direction of the working plane.

Next, the operation of the lift platform in accordance with the invention will be described in more detail.

The working plane 1 is raised or lowered by

means of the lifting cylinder 36, which is attached to the first and second articulated arms 31 and 32, constituting parts of the scissor-like articulated mechanism 3, in the way described above. The movement of the lifting cylinder 36 forces the first and second articulated arms 31 and 32 to pivot relative each other around the first articulated joint 33, whereby the first slide members 12 placed at the upper ends of the first articulated arms 31 glide along the first guides 11 provided on the working plane 1, and correspondingly the second slide members 22 placed at the lower ends of the second articulated arms 32 glide along the second guides 21 placed in the base 2. Depending on the direction of the movement of the lifting cylinders 36, the upper ends of the articulated arms 31 and 32 are hereby raised or lowered, whereby the working plane 1, placed as supported on one of the articulated joints 34 and on one of the slide members 22 is raised or lowered.

The working plane 1 moves in the vertical direction being parallel to the base if the level of the third articulated joint 35 relative the base 2 is adjusted appropriately. In the example shown, the position of the third articulated joint 35 relative the base 2 is correct for keeping the working plane 1 horizontal, i.e. in the vertical direction the said articulated joint 35 is placed at the same level with the second slide members 22 when the tilting arm 41 has been positioned by means of the tilting cylinder 43 parallel to the base 2, i.e. horizontal. The tilting mechanism 4 is dimensioned so that, when the tilting arm 41 is horizontal, the piston rod of the tilting cylinder 43 has been pushed half a stroke out of the cylinder, whereby it is achieved that the tilting allowance of the working plane 1 is, from the horizontal position, equally large in both directions.

Under these circumstances, the working plane 1 is inclined by means of the tilting mechanism 4 as follows: The piston rod of the tilting cylinder 43 displaces the tilting arm 41, whereby a pivoting of the third articulated joint 35, which interconnects the tilting arm 41 and the first articulated arm 31, around the fourth articulated joint 42, the tilting arm 41 constituting the radius for the said pivoting, produces a pivoting of the entire scissor-like articulated mechanism 3 around the second slide member 22, which is placed in the guide 21 and which is connected to the second articulated arm 32, whereby the working plane 1 is tilted.

In accordance with the above, it is an essential feature of the solution in accordance with the invention that the working plane 1 can be tilted in the longitudinal direction in both directions. The working plane 1 is appropriately arranged so that it can be tilted in the longitudinal direction by 10° relative the base 2 in both directions. The tilting allowance may, of course, also be larger than ±10°, but in most cases the said tilting allowance of ±10° is sufficient. Moreover, especially in those cases in which several scissor-like articulated mechanisms 3 placed one above the other are

used, the stability of the equipment may constitute a problem if the tilting extent is considerably above 10°. The tilting of the working plane 1 is performed by tilting the entire scissor-like articulated mechanism 3 of the lift platform. Tilting of the working plane 1 is possible within the whole working range of the lift platform, which has been achieved thereby that the lifting cylinders 36 and the tilting cylinders 43 have been arranged adjustable separately and independently from each other.

Above, the invention has been described by means of an exemplifying embodiment with reference to the figures in the accompanying drawing. This is, however, not supposed to restrict the invention to the exemplifying embodiment illustrated in the figures only, but many variations are possible within the scope of the inventive idea defined in the following patent claims.

### Claims

1. A lift platform comprising a working plane (1), a base (2), and at least one scissor-like articulation mechanism (3) which connects the working plane (1) and the base (2) with each other, the working plane (1) being displaceable substantially vertically relative the base (2) by means of the said articulation mechanism (3) and at least one hydraulic lifting cylinder (36) connected to same and also tiltable longitudinally relative to the base (1), characterised in that a first pair of articulated arms (31) of the crosswise pairs of articulated arms of the single or lowermost scissor-like articulation mechanism (3) are attached to the base (2) by a tilting mechanism (4), by means of which the working plane (1) is tiltable longitudinally to the base (1) in both longitudinal directions by tilting the whole scissor-like articulation mechanism (3).

2. A lift platform as claimed in claim 1, in which the tilting mechanism (4) comprises at least one tilting arm (41) which is by one end attached to the base (2) by means of an articulated joint (42) and by the opposite end attached to the said first articulated arm (31) by means of an articulated joint (35), and the tilting arm (41) is fitted so as to be pivoted around the articulation point (42) by means of a tilting cylinder (43) between the tilting arm (41) and the base (2).

3. A lift platform as claimed in claim 1 or 2, in which the lifting cylinder (36) and the tilting cylinder (43) are separately adjustable so that the working plane (1) can be tilted within its entire operation range.

4. A lift platform as claimed in any preceding claim, in which the degree of longitudinal inclination of the lift platform (1) relative the base (2) is no more than  $\pm 10^\circ$ .

### Patentansprüche

5 1. Hebebühne, welche eine Arbeitsplattform (1), eine Basis (2) und wenigstens einen scherenartigen, gelenkigen Mechanismus (3) umfaßt, der die Arbeitsplattform (1) und die Basis (2) miteinander verbindet, wobei die Arbeitsplattform (1) im wesentlichen vertikal gegenüber der Basis (2) durch den Gelenkmechanismus (3) und wenigstens einen hydraulischen Hubzylinder (36) bewegbar ist, der mit diesem verbunden und auch gegenüber der Basis (2) in Längsrichtung kippbar ist, dadurch *gekennzeichnet*, daß ein erstes Paar von Gelenkarmen (31) der sich paarweise kreuzenden gelenkigen Armen des einzigen oder untersten scherenartig gelenkigen Mechanismus (3) an der Basis (2) mittels eines Schwenkmechanismus (4) angebracht ist, durch den die Arbeitsplattform (1) in Längsrichtung gegenüber der Basis (1) in beiden Lenkrichtungen durch Verschwenken des ganzen scherenartig gelenkigen Mechanismus (3) schwenkbar ist.

25 2. Hebebühne nach Anspruch 1, in der der Schwenkmechanismus (4) wenigstens einen Schwenkbarm (41) aufweist, der mit einem Ende an der Basis (2) mit Hilfe eines Schwenkpunktes (42) angebracht ist und der mit seinem entgegengesetzten Ende an dem genannten ersten Gelenkarm (31) mit Hilfe eines Gelenkpunktes (35) angebracht ist, und der Schwenkbarm (41) so eingepaßt ist, daß er um den Gelenkpunkt (42) mit Hilfe eines Schwenkzylinders (43) zwischen dem Schwenkbarm (41) und der Basis (2) schwenkbar ist.

30 3. Hebebühne nach Anspruch 1 oder 2, dadurch *gekennzeichnet*, daß der Hubzylinder (36) und der Schwenkzylinder (43) getrennt einstellbar sind, so daß die Arbeitsplattform innerhalb des gesamten Arbeitsbereiches schwenkbar ist.

45 4. Hebebühne nach irgendeinem der voranstehenden Ansprüche, dadurch *gekennzeichnet*, daß das Ausmaß der Längsneigung der Arbeitsplattform (1) gegenüber der Basis (2) nicht größer als  $\pm 10^\circ$  ist.

### Revendications

50 1. Plate-forme élévatrice comprenant un plan de travail (1), une base (2) et au moins un mécanisme d'articulation en ciseaux (3) qui relie l'un à l'autre le plan de travail (1) et la base (2), le plan de travail (1) étant disposé de façon déplaçable sensiblement verticalement par rapport à la base (2) au moyen du dit mécanisme d'articulation (3) et d'au moins un vérin de levage hydraulique (36) qui y est relié, et également de façon basculante longitudinalement par rapport à la base (1), caractérisée en ce qu'une première paire de bras articulés (31) des paires croisées de bras articulés du mécanisme d'articulation en ciseaux unique ou le plus bas (3) est reliée à la base (2)

par un mécanisme de basculement (4) au moyen duquel le plan de travail (1) peut basculer longitudinalement par rapport à la base (2) dans les deux directions longitudinales en basculant l'ensemble du mécanisme d'articulation en ciseaux (3). 5

2. Plate-forme élévatrice selon la revendication 1, dans laquelle le mécanisme de basculement (4) comprend au moins un bras de basculement (41) qui est fixé par une extrémité à la base (2) au moyen d'un joint articulé (42) et par l'extrémité opposée au dit premier bras articulé (31) au moyen d'un joint articulé (35), le bras de basculement (41) étant adapté de façon à pouvoir pivoter autour du point d'articulation (42) au moyen d'un vérin de basculement (43) entre le bras de basculement (41) et la base (2). 10 15

3. Plate-forme élévatrice selon la revendication 1 ou 2, dans laquelle le vérin de levage (36) et le vérin de basculement (43) sont réglables séparément de sorte que le plan de travail (1) peut être basculé sur tout son domaine d'utilisation. 20 25

4. Plate-forme élévatrice selon l'une quelconque des revendications précédentes, dans laquelle le degré d'inclinaison longitudinale de la plate-forme élévatrice (1) n'est pas supérieur à  $\pm 10^\circ$ . 30

35

40

45

50

55

60

65

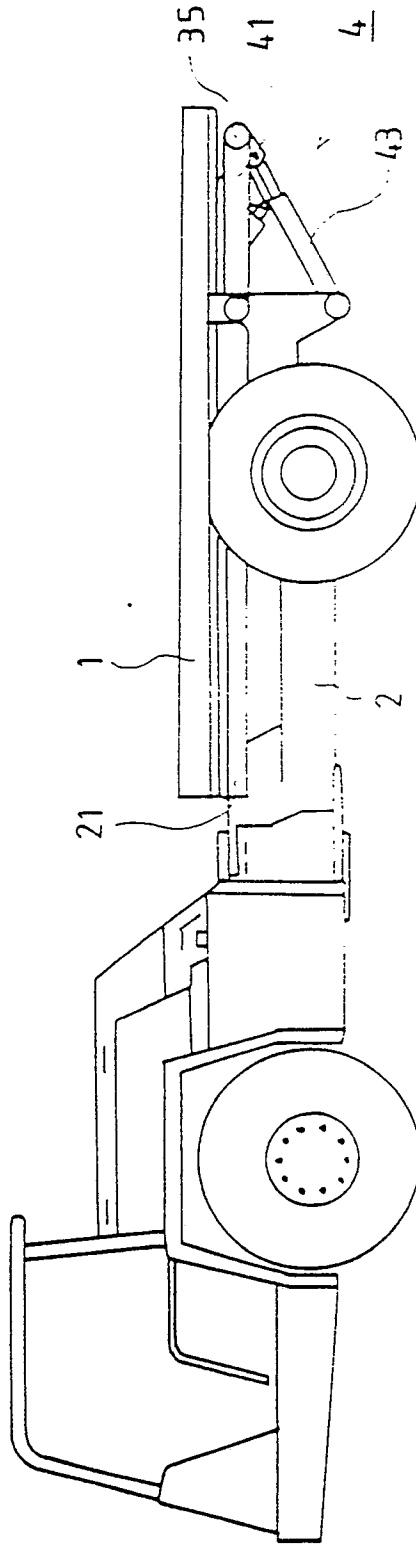

FIG.1

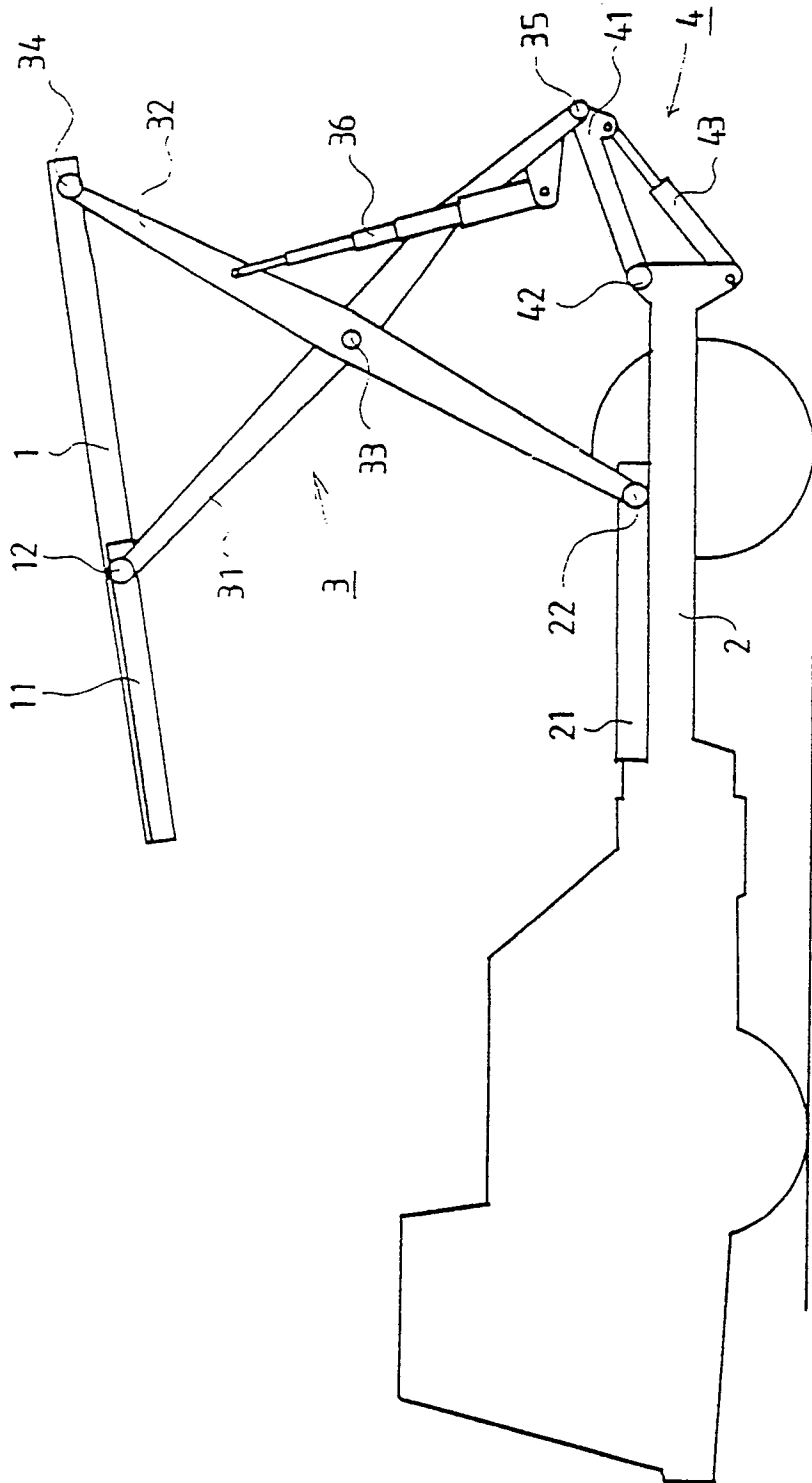

FIG.2

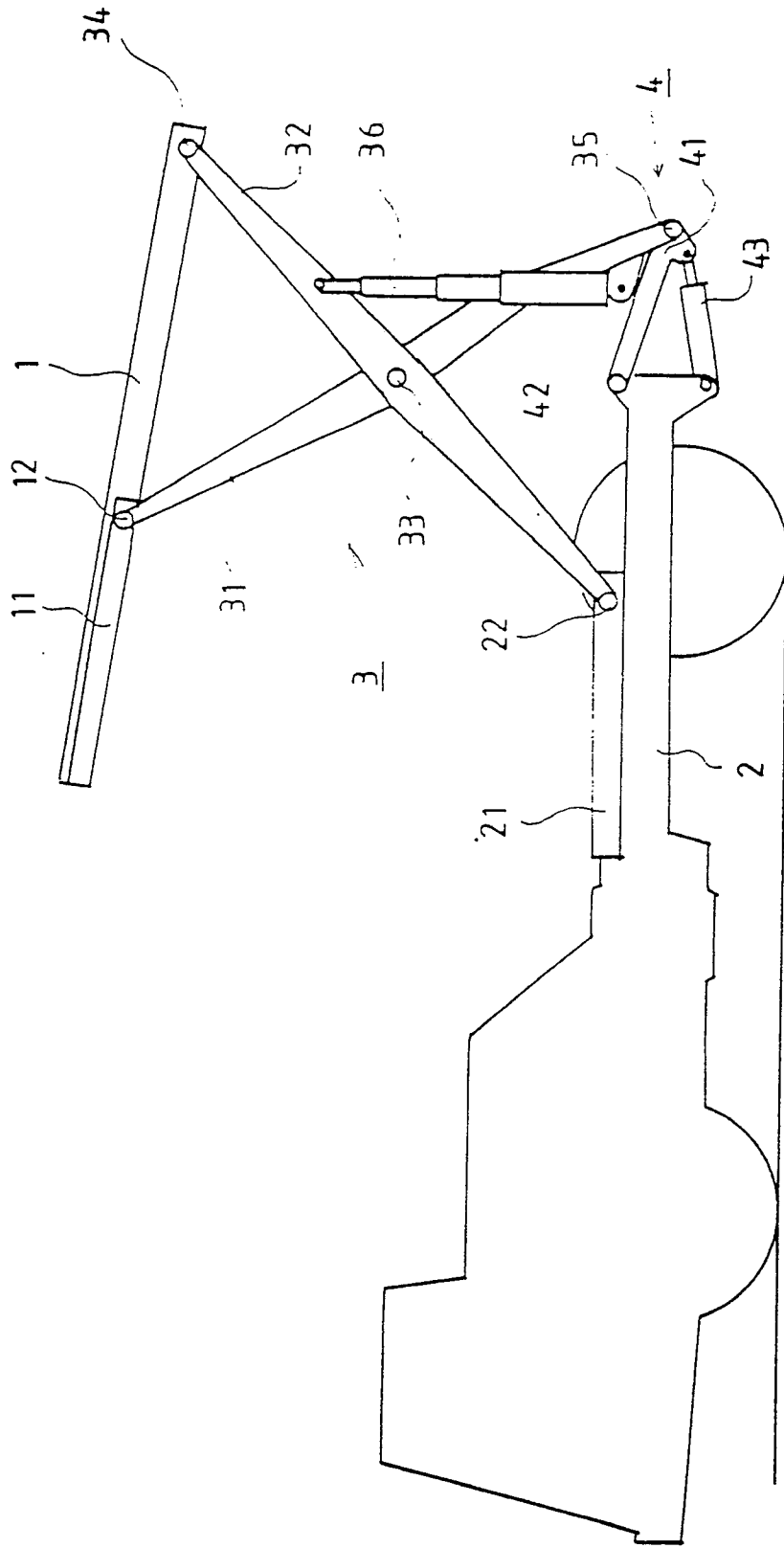

FIG. 3