



Europäisches Patentamt  
European Patent Office  
Office européen des brevets

19

11 Publication number:

**0 269 731**  
**A1**

12

## EUROPEAN PATENT APPLICATION

published in accordance with Art. 158(3) EPC

21 Application number: **86902907.4**

51 Int. Cl.<sup>3</sup>: **G 07 D 9/00**  
**G 07 F 9/06**

22 Date of filing: **06.05.86**

Data of the international application taken as a basis:

86 International application number:  
**PCT/JP86/00233**

87 International publication number:  
**WO87/07059 (19.11.87 87/25)**

43 Date of publication of application:  
**08.06.88 Bulletin 88/23**

84 Designated Contracting States:  
**GB**

71 Applicant: **BONANZA ENTERPRISES LTD.**  
**3-43, Shinyamashita 3-chome Naka-ku**  
**Yokohama-shi, Kanagawa 231(JP)**

72 Inventor: **CHIBA, Kazumi 367-1-401,**  
**Honmokumotomachi**  
**Naka-ku Yokohama-shi**  
**Kanagawa 231(JP)**

74 Representative: **Davies, Christopher Robert et al,**  
**Frank B. Dehn & Co. Imperial House 15-19 Kingsway**  
**London WC2B 6UZ(GB)**

### 54 MONEY STORAGE STRUCTURE.

57 The money storage structure is applied to an exchange machine, a ticket vending machine and an automatic vending machine. A money storage stacker (10) consists of a top plate (32) provided as a drawer type plate under a top wall, and a rear plate (33) provided on the outer side of a rear surface (30) so that the rear plate (33) can be opened and closed. The top plate (32) can be opened by an operation of a key (38) carried out by the field operator when the money storage stacker (10) is set properly in a setting position (37) in the casing, and the stacker (10) as a whole is locked in the setting position (37) in accordance with this operation. When the stacker (10) is locked, a flash display lamp is turned on. The openable rear plate (33) can be opened when a responsible person's key (50) is operated in the opening direction with the top plate (32) in a closed position. Even when the responsible person's key (50) is operated in the closing direction after the openable rear plate (33) has once been opened, the key (50) does not engage the top plate (32). When the top plate (32) is inserted

forcibly under the top wall to be closed after the top plate has been opened, the top plate (32) is locked by a locking means for the openable rear plate (33). Since the field operator's key (38) is housed in the casing and joined to the interior of the casing by a connecting chain (46), the money can be stored without being touched directly by the hand of the field operator.

EP 0 269 731 A1

FIG. 3

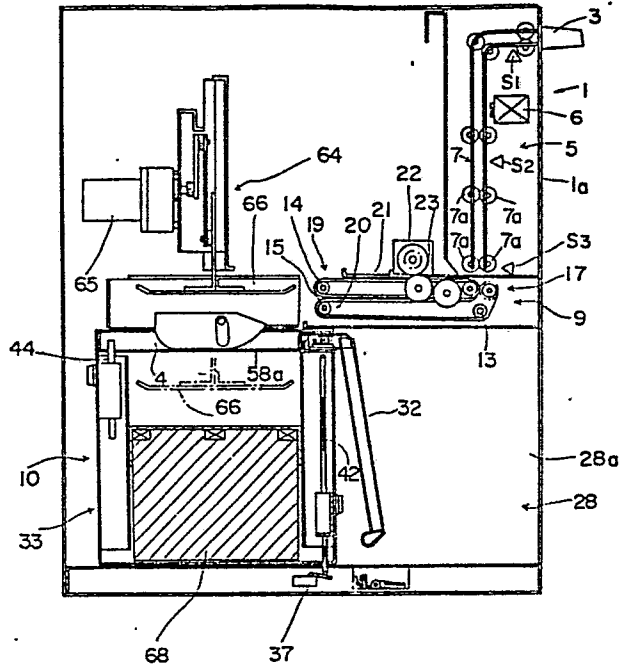

FIG. 4

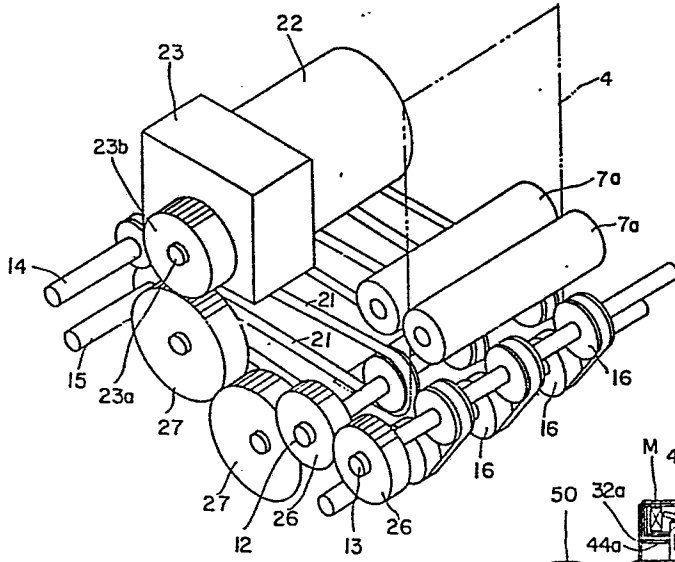
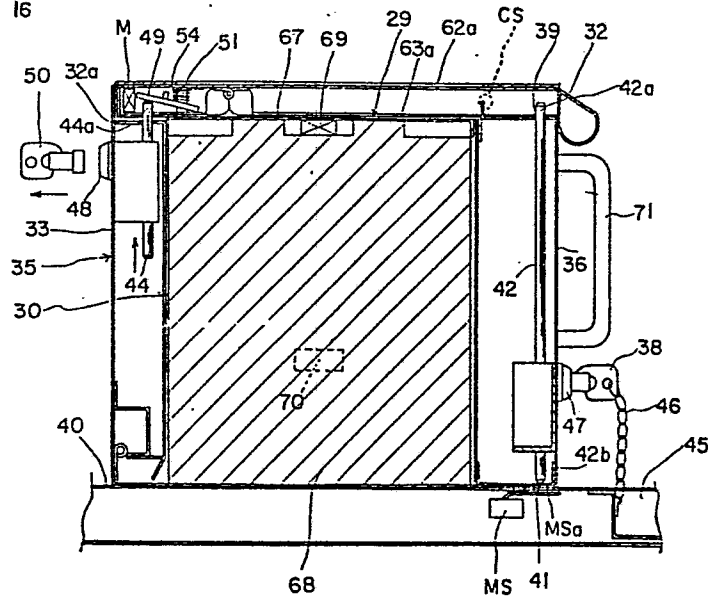

FIG. 14



SpecificationTitle of the Invention

Money Collecting Machine

Technical Field

This invention relates to a money collecting machine, and more particularly to a money collecting machine for use in money exchanging machines, ticket selling machines, automatic vending machines and the like. A money collecting machine according to this invention is capable of preventing any trouble which a conventional machine would suffer upon resumption of the electric power supply which is subsequent to a power outage upon which a money was thrown in, and was on the way to storage; is capable of detecting push-in of a money storing stacker in position and opening of the money storing stacker; is capable of preventing an operator from getting access to the money collected; and is capable of extending and flattening a piece of paper money or bill, which bill has an inclination of rolling itself.

Background Art

As is well known, a money collecting machine is incorporated in a money exchanging machine, a ticket selling machine and an automatic vending machine. A conventional money collecting machine comprises: a coin or bill slot; a money detector for making a decision as to whether the money is genuine or false, and what kind of money it is, and for sending a drive signal for permitting, for instance, money exchange; a money stacker for storing the money thrown in and a money transporting unit for conveying the money from the money detector to the money stacker.

The money transporting unit is composed of a pair of conveyor belts layed on each other for receiving bills therebetween.

When the money is taken out from the money stacker, an operator opens a door of the money collecting machine with a key to get access to the stacked money.

As for the money transporting unit bills are sandwiched between the upper and lower conveyor belts for transporting them in one direction by driving the conveyor belts. Such transporting unit can carry bills without fail, but it has defects as follows:

Among the bills thrown in the money collecting machine there are new and old bills. Some bills are flat, but some bills have an inclination of rolling themselves. When a bill having an inclination rolling itself is used, a person will extend it flat before putting it in the bill slot. Then, the so flat-extended bill is guided by guide means in the money detector, and the money is checked there. Then, the money is sandwiched between the upper and lower conveyor belts, and is transported to the money storing stacker.

When the bill enters the money storing stacker, it is put in stress-free condition, and then the bill often rolls itself. Thus, the rolled bill is put in the stacker. Bills are put in the stacker one after another. Then, it is most likely that the bills are stacked up in disorder. Therefore, it is inconvenient to count the bills which are taken out from the money stacker, whether counting is conducted manually or with the aid of automatic counting machine.

In the conventional money collecting machine when it is desired that the money is taken out of the machine, an operator uses a key to open the door, and then he can get access to the money collected and stored in the machine. The direct access to the money

stored in the machine may be a cause of inducing the operator to steal the money, and therefore the structure which permits the direct access to the stored money is not satisfactory from the angle of management.

In an attempt to solve the problems described above the present inventor proposed an improved money collecting machine as described below, and filed a patent application (PCT/JP85/00728):

The money collecting machine uses a pair of conveyor belts laid on each other for transporting bills. The rear shaft of the upper conveyor belt has a plurality of rolls whose circumferences project somewhat beyond the bill-conveying plane in which the opposing belts are brought in contact with each other. Likewise, the rear shaft of the lower conveyor belt has a plurality of rolls whose circumferences project somewhat beyond the bill-conveying plane. These rear shafts are arranged with their rolls staggered with each other.

Also, a money storing stacker has openings in its ceiling and rear plates, and a ceiling board in the form of drawer is put on the ceiling of the stacker whereas an opening-and-closing rear board is put on the rear side of the stacker casing. These ceiling and rear boards can be locked and unlocked as follows.

The rear board can be unlocked with a key which is placed under the care of a person in charge or manager. The ceiling board can be unlocked with a key which can be used by an operator. The key is chained to the money collecting machine casing, and therefore it can be used only after the money storing stacker has been put in place in the money collecting machine casing. When the money storing stacker is put in place in the money collecting machine casing, and when the key is used to open the ceiling board, the money storing stacker is locked to the casing, and therefore the money storing stacker with its ceiling board open cannot be taken out of the casing. If it is desired that the money storing stacker is taken out, the ceiling board of the stacker must be closed, thereby preventing access to the money which is collected in the money storing stacker.

The proposed structure of money collecting machine is effective in solving the problems described earlier. From the practical point of view, however, the following problem is preferably solved.

Assume that it happens that the electric supply is interrupted in the course of insertion of a bill from the bill slot. The bill which is inserted prior to the power outage can take the following three positions:

(a) the bill was brought to the bill transporting unit after leaving the bill detector; (b) the bill was being checked at the bill detector, but a part of the bill reached the bill transporting unit; and (c) the bill was being checked at the bill detector, and the whole length of the bill remained in the bill detector.

In almost all cases the money collecting machine is so constructed that upon resumption of power supply, a bill is brought back from the bill detector to the bill slot. If the bill is in positions (a) and (c), there is no problem. Specifically, in position (a) in which the bill had already brought in the bill transporting unit, the bill could not be adversely affected by the reverse movement in the bill detector. In position (c) in which the whole length of the bill remained in the bill detector, it could be smoothly brought back to the bill slot by the reverse movement in the bill detector. In position (b) in which a part of the bill had reached the bill transporting unit while the remaining part of the bill was left in the detector, the bill was about to travel forward just prior to the power outage. When the electric power supply was resumed, the reverse movement in the bill detector would cause a pull of the bill, which otherwise, would be brought in the opposite direction

by the bill transporting unit.

The money collecting machine is so constructed that after the money storing stacker is put in right position in the machine casing, the ceiling board is drawn to open the ceiling, thereby permitting the insertion of bills in the inside of the money storing stacker. In this connection bills cannot be stored unless the money storing stacker has been put in right position and the ceiling board has been fully drawn. But, it is difficult to check whether the ceiling board has been fully drawn or not. Therefore, an operator often overlooks wrong positioning of the money storing stacker and/or incomplete drawing of the ceiling board, and then malfunctions will be caused.

In view of the above the object of the first invention for which a patent is claimed, is to provide a money collecting machine which is capable of: (1) preventing pull of a bill between the bill detector and the bill transporting unit, which pull would be, otherwise, caused if the electric power supply is resumed; (2) thereby reducing the trouble due to a power outage to possible minimum; (3) accordingly making it sure to put the money collecting machine in a trouble-free condition upon resumption of the electric power supply; and (4) not only transporting bills to

the money storing stacker but also flattening a bill which has an inclination of rolling itself prior to stacking in the money storing stacker. The object of the second invention for which a patent is claimed, too, is to provide a money collecting machine which, in addition to the item 1 to 4 above, permits (5) the money storing stacker containing money therein to open only with a key which is placed under the care of a person in charge; (6) therefore permitting the stored money to be collected without fear of allowing an operator to have direct access to the money, (7) thereby preventing the stored money to be stolen or lost, and assuring reliable management of the collected money; and (8) permitting the operator to make confirmation of right positioning of the money storing stacker and full-opening of the ceiling of the money storing stacker with the aid of an indicator lamp, thereby preventing any handling miss in the place where practical operations happen.

#### Disclosure of the Invention

To attain the above described objects the present invention provides a money collecting machine as described below:

By using the reference numerals as used in the accompanying drawings in which a preferred embodiment is shown, first, a money collecting machine according to the first invention for which patent is claimed, is described. Such a money collecting machine is appropriate for incorporating in a money exchanger, a ticket selling machine, an automatic vending machine etc. A money collecting machine according to the first invention comprises: in a casing, a bill slot; a bill detector for making a decision as to whether the bill thrown into the bill slot is genuine or false, and what kind of bill it is, said bill detector being capable of sending a drive signal such as an instruction signal for permitting the exchange of money, and being capable of returning the bill to the bill slot upon resumption of the electric power supply subsequent to a power outage; and a bill transporting unit for transporting bills from the outlet of the bill detector to a bill storing stacker, said bill transporting unit 9 comprising a pair of upper and lower conveyors 11a and 11b laid on each other, thereby sandwiching bills 4 therebetween, each conveyor 11a or 11b comprising a front shaft 12 or 13 on the upstream side as viewed in the direction in which bills 4 are to be travelled, a front pulley group 17 or 18 made up by a plurality of

pulleys 16 fixed to the front shaft 12 or 13 at predetermined intervals, a rear shaft 14 or 15 on the downstream side, a rear pulley group 19 or 20 made up by a plurality of pulleys 16 fixed to the rear shaft 14 or 15 at predetermined intervals, endless belts 21 connecting the pulleys of the front and rear pulley groups, a gear wheel 26 fixed to either of the front or rear shafts 12, 13 or 14, 15, the gear wheels 26 and 26 of the upper and lower conveyors being engaged, via pinion gears 27, 27 with a driving gear wheel 23b fixed to the shaft 23a of a motor 22; a clutch 23 interconnecting the motor shaft 23a and the gear wheels 26 and 26, and being responsive to a disconnection signal "n2" for disconnecting the gear wheels 26 and 26 from the motor shaft 23a, which disconnection signal "n2" is generated by a control 8 in case that a bill remains partly in the bill detector 5 upon resumption of the electric power supply subsequent to a power outage, and said clutch 23 being responsive to a connection signal "n1" for connecting the gear wheels 26 and 26 with the motor shaft 23a, which connection signal "n1" is generated by the control 8 a predetermined time after receipt of the disconnection signal by the clutch 23, each of the rear shafts of the upper and lower conveyors 11a and 11b having a

plurality of rolls 24 of such a diameter that their circumferences project somewhat beyond the bill-conveying plane 25 in which the upper and lower conveyor belts oppose to each other, the rolls 24 of the rear shaft of the upper conveyor 14 being staggered with the rolls 24 of the rear shaft of the lower conveyor 15. A money collecting machine according to the second invention has the same structure as described above, and further comprises a bill storing stacker 10 which is modified according to the present invention as follows: The stacker 10 comprises a stacker casing 31 having openings in its ceiling 29 and rear side 30, a ceiling board 32 which is adapted to open and close the ceiling opening, a rear board 33 which is adapted to open and close the rear opening, a front latch bolt 42 movably fixed to the back of the stacker casing 31, the front latch bolt 42 being adapted to descend, leave from a catch hole 39 made in the back of the ceiling board 32 and fall in a catch hole 41 made in the bottom panel 40 of the casing 1a of the money collecting machine by using an operator key, thereby enabling the stacker to be put in its opening position after having put the stacker 10 in right position in the casing 1a of the money collecting machine, and the front latch bolt 42 being adapted to

rise, leave the catch hole 41 made in the bottom panel 40 of the casing 1a of the money collecting machine and enter the catch hole 39 made in the ceiling panel 32 by using the operator key, thereby putting the stacker in its closing position; and the money collecting machine still further comprises a micro switch MS responsive to the descent of the latch bolt 42 into the lower catch hole 41 in the bottom panel of the casing 1a of the money collecting machine for lighting an indication lamp 76, thereby permitting the operator to confirm that the stacker has been put in right position; a magnet M fixed to the rear, side edge of the ceiling board 32 and a cover sensor CS fixed to the casing 1a of the money collecting machine at such a position that the sensor CS may detect the magnetic force from the magnet M when the ceiling board has been drawn to its full length, thereby lighting an indication lamp 76 and permitting the operator to confirm that the ceiling board 32 has been drawn to its full length; and a rear latch bolt 44 movably fixed to the back of the rear hinged panel 33 of the stacker casing 31, the rear latch bolt 44 being adapted to descend, leave the notch 53 of a catch hook 49 when a person in charge, or manager uses a manager key for putting the rear panel in its opening position, the catch hook being rotatably

fixed to the back of the ceiling board, and being spring-biased to keep its notch 53 in engagement with the rear latch bolt 44 by a spring 54, but being adapted to turn to its disengaged position by the spring 54 once the rear latch bolt 44 has been released from the catch hook 49 for opening the rear panel 33, in the disengaged position the catch hook 49 preventing the rise of the rear latch bolt 44 by causing the tip end 44a of the rear latch bolt 44 to strike against the lower surface 49' of the catch hook 49; the hinged rear board 33 being adapted to be locked to the stacker casing by pushing the ceiling board 32 to close the ceiling opening, then causing the rear latch bolt 44 to strike against the guide slope 52 of the catch hook 49 to rotate the catch hook 49 and permit the rear latch bolt 44 to snap in the notch 53 of the catch hook 49; and the operator key being connected to the casing of the money collecting machine with a chain 46 the length of which is adequate to permit the operator to use the operator key only when the bill storing stacker 10 has been put in right position 37 in the casing 1a of the money collecting machine casing 1a.

In operation a bill 4 is inserted into the bill slot 3, and then the bill detector 5 makes a decision as to whether the bill 4 is genuine or false, and as to what kind of bill it is. When the decision has been made, the bill 4 is discharged to the bill transporting unit 9, and then a drive signal is sent to the automatic vending machine 2, depending on the result of detection by the bill detector 5. The bill is carried to the bill storing stacker 10 by the transporting unit 9. If the electric power should be interrupted in the course of collection, every movement will stop in the money collecting machine. Assume that at the time the electric power supply is resumed, the bill 4 happens to remain in the detector 5, and then the bill 4 must be returned to the bill slot 3 for recommencement. In case that the whole of the bill remains in the money detector at the time of a power outage, there will be no trouble in returning the bill to the bill slot. However, if a part of the bill 4 should be caught by the bill transporting unit 9 at the time of a power outage, the bill 4 will be stretched by the money detector 5 and the bill transporting unit 9 in the opposite directions at the time the electric power supply is resumed. In an attempt to avoid this trouble, a money collecting machine according to the

present invention uses a clutch mechanism 23 in the torque transmission system connected to the upper and lower conveyors 11a and 11b, and when it is desired that the bill 4 is returned to the bill slot 3 upon resumption of the electric power supply, the clutch mechanism 23 is responsive to resumption of the electric power supply for disconnection, thereby preventing the stretch of the bill between the transporting unit 9 and the detector 5.

The money transporting unit 9 conveys bills 4 from the detector 5 to the bill storing stacker 10. It is composed of a pair of upper and lower conveyors 11a and 11b. A plurality of rolles 24 have their circumferences projecting somewhat beyond the bill-transporting plane 25, in which the opposing belts are laid on each other. These rolles 24 are arranged in the alternate staggering relation on the exit side of the money transporting unit. With this arrangement a bill which has an inclination of rolling itself, will be flattened before discharging into the bill storing stacker 10.

The bill storing stacker 10 is detachably fitted in the casing 1a of the money collecting machine. The stacker 10 has a ceiling board 32 and a rear board 33. These boards 32 and 33 can be unlocked with different

keys to open. Specifically, the rear board 33 can be unlocked with a manager key, which is placed in the care of a person in charge or manager, whereas the ceiling board 32 can be unlocked with an operator key, which is put in the casing 1a of the money collecting machine, and is connected to the casing 1a by a chain 46 whose length is adequate to permit an operator to use the key only when the bill storing stacker 10 has been put in the right position in the casing 1a of the money collecting machine. In this connection the ceiling board 32 cannot be opened unless the bill storing stacker 10 has been put in the right position in the casing 1a of the money collecting machine. When the ceiling board 32 is drawn to open the bill storing stacker 10, the front latch bolt is lowered to lock the bill storing stacker 10 to the casing 1a of the money collecting machine, thus preventing the withdrawal of the money storing stacker 10 with its ceiling open.

When the bill storing stacker 10 is loaded with bills 4 to its full capacity, or at regular intervals the stacker 10 is taken out of the automatic vending machine. Then, the ceiling board 32 is raised and pushed to the closing position, in which the catch hook 49 catches the rear latch bolt 44, thereby preventing the rear board 33 and the ceiling board 32 from

opening. The operator uses an operator key to raise the front latch bolt 42, thereby unlocking and releasing the stacker casing 31 from the casing 1a of the money collecting machine. Then, the stacker 31 can be taken out. The ceiling board 32 and the rear board 33 are locked, and therefore the operator cannot have access to the money stored therein. When the manager uses his key to lower the rear latch bolt 44, the rear board 33 can be opened, thereby permitting the manager to have access to the money stored in the stacker. After taking the money out of the stacker 10, the manager uses his key 50 to raise the rear latch bolt 44, which strikes against the lower surface of the catch hook 49.

When the bill storing stacker 10 has been put in the right position in the casing 1a of the money collecting machine, and when the stacker has been locked to the casing 1a by lowering the front latch bolt 42, the micro switch MS turns on. When the ceiling board 32 has been drawn to its full length, the indicating lamp 76 is lit. Therefore, the operator can confirm by sight that the money collecting machine has been put in working condition.

In the first invention (1) use is made of a clutch mechanism 23 between the pulley gears 26, 26, which are

fixed to the drive shafts of the conveyers 11a, 11b, and the motor 22 for driving the upper and lower conveyers, and in order that a bill which has been thrown into the bill slot 3 just prior to a power outage is returned to the bill slot upon resumption of the electric power supply, the clutch mechanism 23 is operated for disconnection, thereby preventing the bill 4 from being stretched between the money detector 5 and the money transporting unit 9, thus (2) reducing the trouble due to a power outage to possible minimum; (3) accordingly enabling the money collecting machine to work without trouble upon resumption of the electric power supply; and (4) not only transporting bills to the bill storing stacker 10 but also flattening a bill which has an inclination of rolling itself prior to stacking bills in the stacker. A money collecting machine according to the second invention additionally permits (5) the bill storing stacker 10 to be opened only with a manager key 50 which is placed under the care of a person in charge or manager; (6) therefore permitting the stored money to be collected without fear of direct access by an operator to the money, (7) thereby preventing the stored money to be stolen or lost, and assuring reliable management of the collected money; and (8) permitting confirmation by sight of

right positioning of the bill storing stacker and full opening of the ceiling of the bill storing stacker with the aid of an indicator lamp, thereby preventing any handling miss in the place where practical operations happen.

#### Brief Description of the Drawings

The accompanying drawings show a money collecting machine according to an embodiment of the present invention:

Fig. 1 is a perspective view of the body of the money collecting machine;

Fig. 2 is a perspective view of an automatic vending machine having the money collecting machine incorporated therein;

Fig. 3 is a longitudinal section of the money collecting machine taken along the line A-A;

Fig. 4 is a perspective view of a money transporting unit;

Fig. 5 is a block diagram of a control system operating upon resumption of the electric power supply;

Fig. 6 is a front view of the front pulley group in the conveyor system;

Fig. 7 is a front view of the rear pulley group in

the conveyor system;

Fig. 8 is a sectional view of the rear pulley group in the conveyor system;

Fig. 9 is a perspective view of a flattened bill, showing how it rolled itself;

Fig. 10 is a plan view showing how a bill is laid on the top of the bill storing stacker.

Fig. 11 is a front view of the bill storing stacker;

Fig. 12 is a plan view of the bill storing stacker;

Fig. 13 is a rear view of the bill storing stacker;

Fig. 14 is a sectional view taken along the line C1-C2-C3-C4-C5-C6 in Fig. 12.

Fig. 15 shows how the rear latch bolt is engaged with the catch hook;

Fig. 16 shows how the rear latch bolt strikes against the lower surface of the catch hook.

Fig. 17 shows how a microswitch and a cover sensor are connected to each other;

Figs. 18 to 20 show how the bill storing stacker is set in position; specifically, Fig. 18 shows the stacker with its ceiling board pulled out; Fig. 19 shows the stacker with its ceiling board pushed in; and Fig. 20 how the rear board is opened;

Fig. 21 is a perspective view of the ceiling board;

Fig. 22 is a perspective view of the catch hook fixed to the ceiling board;

Fig. 23 is an explosive view of the stacker casing;

Fig. 24 is a perspective view of a guide means;

Figs. 25 to 27 show how a swing guide works, specifically Fig. 25 shows how the swing guide is raised when it is pushed by the front top of the stacker casing; Fig. 26 shows the swing guide laid on the ceiling board; and Fig. 27 shows how the swing guide is brought in contact with the lower edge support.

#### Best Embodiment of the Present Invention

A money collecting machine is generally indicated at 1, and it is incorporated in an automatic vending machine 2 as shown in Fig. 2 to collect money thrown into the vending machine 2. There are money collecting machines for exclusive use for coins or bills and for common use for coins and bills. A money collecting machine according to this particular embodiment is described as being for exclusive use in collecting bills. It is constructed as follows: The money collecting machine is made in the form of box as shown

in Fig. 1, and it has a bill slot 3 in front. The bill slot 3 is provided for directing bills 4 to the money collecting machine 1 when they are thrown into the automatic vending machine 2.

A money detector is indicated at 5. It functions to make a decision as to whether a bill 4 which is thrown into the bill slot 3 is genuine or false, and what kind bill it is, and then it functions to send a drive signal to the automatic vending machine 2. Specifically, the detector 5 has a money detecting sensor 6. When a bill 4 is carried by a transporting means 7 to pass in front of the sensor 6, the sensor 6 detects the bill in terms of size, thickness, color and other factors to make a decision as to whether the bill 4 is genuine or false, and what kind bill it is. The transporting means 7 is shown as comprising a plurality of opposing rollers 7a in this particular embodiment. These rollers 7a are responsive to a drive signal "m" from a control 8 for turning either in forward or backward direction. An entrance sensor S1 is put at the entrance of the money detector 5; an intermediate sensor S2 is put at the intermediate position between the entrance and the exit of the detector 5; and an exit sensor S3 is put at the exit of the detector 5. When these sensors detect a bill 4, they send detection

signals "i1", "i2" and "i3" to the control 8. The control 8 is responsive to these detection signals to send a forward drive signal "m1" to the transporting means 7, thereby putting the transporting means 7 in detection signals upon resumption of the electric power supply the control 8 will send a backward drive signal "m2" to the transporting means 7, thereby putting the transporting means 7 in backward movement.

After the bill 4 has passed the check at the money detector 5 the bill 4 is transported to a bill storing stacker 10 by a money transporting means 9, which is positioned downstream of the detector 5.

The money transporting means 9 is composed of a pair of upper and lower conveyors 11a and 11b. These conveyors have front and rear shafts 12, 13 and 14, 15 as viewed in the direction in which bills are transported. Each of these shafts has three pulleys 16, forming front pulley groups 17 and 18, and rear pulley groups 19, 20. The pulleys of the front, upper group 17 and those of the rear, upper group 19 are connected by endless belts 21 to form an upper belt conveyor 11a. The pulleys of the front, lower group 18 and those of the rear, lower group 20 are connected by endless belts 21 to form a lower conveyor 11b.

The rear, upper and lower shafts 14 and 15 have

extra rolles 24a and 24b. Each of these rolles 24a has two large disks "a" and "b" fixed at opposite ends of its shaft, and each of these disks has a rubber ring 24c fixed therearound. Each of the rolles 24b has one large disk "c" fixed at the center of its shaft, and the disk "c" has a rubber ring 24c fixed therearound. Some details are shown in Figs. 7 and 8.

These rolles 24a and 24b have the effect of extending and flattening, in the course of transportation, bills which have an inclination of rolling themselves, if any. To attain this object these rolles have to meet the following requirements.

First, the circumferences of the rubber rings 24c around the large disks project somewhat beyond the plane in which the upper and lower conveyer belts oppose to each other to sandwich bills therebetween for carrying them. In Fig. 8 the ring projection beyond the bill-transporting plane is indicated at 25', and the amount of projection with respect to the bill-transporting plane is indicated at  $\Delta t$ .

Second, the enlarged rolles 24a and 24b of the rear shafts 14 and 15 are arranged to each other with their projections staggered alternately. This staggering arrangement has the effect of extending and flattening bills which have an inclination of rolling

themselves.

The upper and lower conveyers 11a and 11b are adapted to be driven by a motor 22. As shown in Fig. 4, the motor 22 is equipped with a reduction gear-and-clutch mechanism 23. Torque can be transmitted from the drive gear 23b of the motor shaft 23a to the pulley gears 26, 26 of the front shafts 12 and 13 of the conveyers via the intermediate pinions 27, 27.

The reduction gear-and-clutch mechanism 23 is used to prevent transmission of torque from the motor 22 to the conveyer system in case that a bill 4 partly remains in the money detector 5 upon resumption of the electric power supply, and the mechanism 23 will effect disconnection in response to a disconnection signal "n2" from the control 8, and will effect connection in response to a connection signal "n1", which a timer in the control 8 provides a predetermined time after generation of the disconnection signal "n2".

A bill storing stacker 10 is explained below in some details:

It is made in the form of box, and it can be fitted in a stacker compartment 28 provided at the lower part of the money collecting machine casing 1a. The stacker 9 comprises a stacker casing 31 having openings on its ceiling 29 and rear side 30, a ceiling

board 32 and a rear board 33. The ceiling board 32 is adapted to be drawn out with respect to the ceiling of the stacker casing 31, and the rear board 33 is adapted to rise and fall, thereby opening and closing the rear opening of the stacker casing. These ceiling and rear boards 32 and 33 can be locked and unlocked to the stacker casing 31 by front and rear locks 34 and 35.

The front lock 34 comprises a front latch bolt 42 movably fixed to the back of the front board 36 of the stacker casing 31. The front latch bolt 42 is biased upward by a spring 43 to rise and fit in a counter catch hole 39 made in the ceiling board 32 when it is laid on the ceiling of the stacker casing 31, thus locking the ceiling board 32 to the stacker casing 31. After the stacker casing 31 has been put in right position in the money collecting machine casing 1a, an operator key is used to lower the front latch bolt 42 until the front latch bolt 42 is put in a counter catch hole 41 made on the bottom plate 40 of the money collecting machine casing 1a, thus fixedly setting the stacker casing in position. Specifically, when the operator key 38 is put in the key hole 47 to turn the key 38, the front latch bolt 42 will be lowered to unlatch the ceiling board 32 and, at the same time, latch and fix the stacker casing 31 to the money

collecting machine casing 1a. When the ceiling board 32 is withdrawn to open the ceiling of the stacker, the tip end 42a of the front latch bolt 42 is put in contact with the under surface of the rear end of the ceiling board 32, thereby preventing the front latch bolt 42 from rising upward. Thus, the stacker casing 31 cannot be unlocked and taken out with its ceiling board 32 withdrawn to open the ceiling of the stacker. The front latch bolt 42 can be raised and lowered by using the operator key 38, which is connected by a chain 46 to and is put in a key recess 45, which is made on the bottom plate 40 of the stacker compartment 28 of the money collecting machine casing. The length of the chain 46 is adequate to allow an operator to insert the key 38 into the key hole 47 of the bill storing stacker 10 only when the stacker 10 has been set in right position. Therefore, the key 38 cannot be used to withdraw the ceiling board 32 for opening the stacker ceiling when the stacker 10 is taken out of the money collecting machine casing.

The rear lock 35 comprises a rear latch bolt 44 and a catch hook 49. The rear latch bolt 44 is movably fixed to the back of the rear hinged panel 33, and the catch hook 49 is pivotted to the ceiling board 32. A manager key 50 is placed under the care of a person in

charge or manager. The rear latch bolt 44 can be raised or lowered by inserting the manager key 50 into the key hole 48 on the rear panel 33 and by turning the key 50 in the key hole 48. When the rear latch bolt 44 is lowered, it leaves the catch hook 49, and then the rear panel 33 is ready to open.

The catch hook 49 is rotatably fixed about a pivot 51 standing on the lower metal sheet of the the ceiling board 32. As shown, it has a guide edge 52 converging towards its end, and an inner-curved catch edge 53 at its rear side. The catch hook 49 is urged by a spring 54 so that it may catch the rear latch bolt 44 with its catch edge 53, thereby preventing undesired release of the latch bolt 44 from the catch hook 49.

When the rear latch bolt 44 is lowered to make it leave the catch hook 49, the catch hook is made to turn to the disengaging position under the influence of the spring 54. In this position if the rear latch bolt 44 should be raised, its tip end 44a strikes against the back 49' of the catch hook 49 as shown in Figs. 14 and 16, and it cannot be caught by the catch hook 49, thus not preventing withdrawal of the ceiling board 32. As shown, the rear end of the ceiling board has a slot 32a, thereby permitting withdrawal and advance of the ceiling board 32 even if the rear latch bolt 44 is

raised upward.

In use the bill storing stacker 10 made up as described above, is put in the money collecting casing 1a. It is, however, difficult to check by sight whether or not the bill storing stacker 10 has been put in right position, and whether or not the ceiling board 32 has been drawn to its fullest extent after the work has been finished. The present invention makes it possible to check by sight whether or not the work has been correctly completed.

A microswitch MS is put under the bottom of the stacker casing, and the contact MSa of the microswitch MS extends to below the catch hole 41 so as to cause the microswitch MS to turn on in response to the descent of the front latch bolt 42.

Also, a magnet M is fixed to one side of the rear end of the ceiling board 32, and a cover sensor CS is fixed to the side wall 28a of the money collecting machine casing 1a at such a position that the sensor CS may oppose the magnet M when the ceiling board 32 has been withdrawn to its fullest extent, thereby causing the sensor CS to turn on.

As shown in Fig. 17, the microswitch MS and the cover sensor CS are series-connected to the control 8, thereby lighting an indicating lamp 76 on the money

collecting machine casing 1a only when both of the microswitch and the covering sensor have turned on.

A guide means 55 is provided to the discharging end of the money transporting unit 9 for the purpose of putting bills 4 at right position above the bill storing stacker 10. The guide means 55 is constructed as follows: a pair of guide support pieces 57, 57 are attached to opposite frame beams 56, 56 at a level above the bill storing stacker 10. Each guide support piece 57 is attached to the frame beam 56 by inserting bolts 58 in the slots 57a of the guide support piece and the holes of the frame beam 56. The guide support pieces 57, 57 can be moved towards or apart from each other. As shown, each guide support piece 57 has support pins 59, 59 projecting from its back, and an associated swingable guide piece 60 is attached to the guide support piece 57 with the support pin 59 of the guide support piece inserted in the longitudinal slot 61 of the swingable guide piece 60, thereby permitting the swingable guide piece 60 to swing and move vertically.

The ceiling of the bill storing stacker casing 31 on which bills are to be guided by the swingable guide pieces, has opposite upper and lower longitudinal rails 62 and 63 for supporting slidably the ceiling

board 32. Openings 62a and 63a are defined by these rails 62 and 63. Specifically, the upper opening 62a is large enough to allow bills 4 to pass therethrough, whereas the width  $W$  of the lower opening 63a is somewhat shorter than the width  $W'$  of bill 4, thereby allowing it to lie across the lower opening 63a.

A pusher 64 is positioned above the bill storing stacker 10, and it is responsive to transportation of the bill 4 to the lower opening 63a for driving an associated motor 65 to lower a pushing plate 66 and put bills one after another on the bill-supporting plate 67 in the stacker 10.

A resilient member 68 is made of a resilient material such as urethane sponge rubber, and is used for cushioning the bill-supporting plate 67. A magnet 69 is fixed to the lower surface of the bill-supporting plate 67 for permitting the detection of the descent of the bill-supporting plate 67. When the bill-supporting plate 67 has been lowered to the level at which a magnet detecting sensor 70 is fixed to the wall 28a of the money collecting machine casing, the magnet detecting sensor 70 will turn on to inform that the bill storing stacker 10 has been loaded with bills 4 to its full capacity. A grip 71 is fixed to the front plate 36 for facilitating push and pull of the bill

storing stacker casing 31 in and out of the stacker compartment 28.

The operation of the money collecting machine is described below:

When a bill 4 is thrown into the bill slot 3, the entrance sensor S1 which is positioned on the entrance side of the money detector 5, detects the bill 4 to send a bill detection signal "il" to the control 8. Then, the control 8 provides a forward-drive signal "ml" to the bill transporting means 7 in the money detector 5 so that the bill transporting means 7 may be driven in the forward direction. At the same time, the bill transporting unit 9 is made to start moving. The transporting means 7 carries the bill 4 from the entrance to the exit of the money detection 5. When the bill 4 passes by the bill sensor 6, a decision is made of the genuineness and kind of the bill in terms of its size, thickness and color, and then a drive signal is sent to the automatic vending machine 2 depending upon the result of the decision, so that a desired article which costs the money put in by the customer, may be discharged.

After the bill 4 has been checked, it is transported to the exit of the money detector 5 by the transporting means 7. In the course of travel to the

exit of the money detector 5 the bill 4 passes by the intermediate sensor S2. Then, the intermediate sensor S2 sends a bill detecting signal "i2" to the control 8. The control 8 makes the bill transporting means 7 stop for a while in response to the bill detecting signal "i2", permitting the bill travelling towards the exit of the detector 5. When the bill 4 is discharged from the money detector 5 to the transporting unit 9, the exit sensor S3 detects the outgoing bill 4 to provide a bill detecting signal "i2". The detection of the bill at the money detector 5 will end with the termination of the bill detecting signal "i3". Then, the drive signal is sent to the automatic vending machine 2 as described earlier.

The money transporting unit 9 for use in transporting bills 4 from the money detector 5 to the bill storing stacker 10 is equipped with a clutch mechanism 23 for controlling transmission of torque from the motor 22 to the money transporting unit 9. The clutch mechanism 23 is normally put in the condition of connection in response to the connection signal "n1" from the control 8, thereby permitting the transporting unit 9 to carry bills 4 to the bill storing stacker 10.

The normal operation of the money detector 5 and

money transporting unit 9 is described above. Assume that unfortunately a power outage happens before finishing detection of the bill which has been thrown into the bill slot 3. The money detector 5 and the money transporting unit 9 operate at the time the electric power supply is resumed as follows: at the moment the electric power supply is resumed an electric power supply signal "g" is sent to the control 8, and then the entrance, intermediate and exit signals S1, S2 and S3 are sent to the control 8 to cause the control 8 to send a reverse drive signal "m2" to the transporting means 7.

The transporting means 7 reverses its transporting operation in response to the reverse drive signal to return the bill 4 to the bill slot 3. If the bill 4 remains in the money detector 5 at the time the transportation is reversed, the bill will be smoothly returned to the bill slot 3. However, if a part of the bill 4 reaches the bill transporting unit 9, and if the transporting unit 9 starts transportation of the bill towards the bill storing stacker 10, the bill 4 will be pulled in the opposite directions by the transporting unit 9 and the transporting means 7, which has reversed transportation in direction. In an attempt to solve this problem the money collecting machine according to

the present invention uses the clutch mechanism 23. When the control 8 sends a reverse drive signal "m2" to the transporting means 7 upon resumption of the electric power supply, the control 8 sends a disconnection signal "m2" to the clutch mechanism 23 to put it in the condition of disconnection. As a result the torque cannot be transmitted from the motor 22 to the front shafts 12 and 13, and then the upper and lower conveyer belts 11a and 11b are not driven. Thus, the bill cannot be pulled in the opposite directions when the transporting means starts reversing transportation upon resumption of the electric power supply.

The control 8 sends a connection signal "n1" to the clutch mechanism 23 after a while to put it in the condition of connection.

After being discharged from the money detector 5 the bill 4 is sandwiched between the upper and lower conveyers 11a and 11b, and is carried to the bill storing stacker 10. At the rear end of the conveyer the bill 4 is flattened to rid the bill of the inclination of rolling itself before it is discharged to the bill storing stacker 10. As described earlier, the rear shafts 14 and 15 of the upper and lower conveyers 11a and 11b have a plurality of rollers 24a

and 24b fixed thereon, and their rings 24c of increased diameters "a", "b" and "c" project somewhat beyond the bill-carrying plane in which the upper and lower conveyer belts are opposed to each other.

Specifically, each rolle 24a has two increased diameters "a" and "b" at its opposite ends, whereas each rolle 24b has one increased diameter "c" at its center. These rolles 24a and 24b are arranged with their increased diameters staggering with each other on the opposing rear shafts 14 and 15., thereby forming an alinement of projecting and sinking portions 72 and 73 across the path on which bills travel towards the stacker 10. This arrangement has the effect of ridding bills of their inclination of rolling and folding themselves.

After being discharged from the conveyer system, the bill 4 is guided by the guide means 55 which is positioned ahead of the conveyer system, and then the bill 4 is laid on the bill string stacker 10. The guide means 55 comprises a pair of opposite swingable pieces 60 and 60. As shown in solid line in Fig. 25, these swingable pieces 60 and 60 are suspended oblique before the bill storing stacker 10 is put in position. The bill storing stacker 10 is pushed in the money collecting machine casing 1a to push and raise the

swingable pieces 60 and 60 as indicated by arrow 74 in Fig. 25. When the bill storing stacker 10 has been put in position, the swingable pieces 60 and 60 are laid horizontally on the ceiling board 32 as shown in Fig. 26. Then, the ceiling board 32 is withdrawn, and accordingly the rear portions of the swingable pieces 60 and 60 descend, and subsequently the front portions 60b descend. Finally, the swingable pieces 60 and 60 are laid on the lower rails 63 of the stacker casing.

The bill 4 is guided by a pair of swingable pieces 60 and 60 to the correct position, and then it is pushed in the inside of the bill storing stacker 10 through the lower opening 63a of the stacker 10. Therefore, bills are stacked on each other in order. When the bill 4 is laid on the lower opening 63a, the feeding means 64 starts operation, lowering the pusher plate 66 to push the bill 4 in the stacker 10.

As described above, the bill storing stacker 10, is removably fitted in the money collecting machine. It has a slidable ceiling board 32 on its ceiling 29 and a rear plate 33 on its rear side 30. The ceiling board 32 can be put in the condition of being withdrawn from the ceiling of the stacker 10 by using the operator key 38 to lower the front latch bolt 42. The operator key 38 is connected by a limited length of

chain 46, and is put in the recess 45 made on the bottom of the money collecting machine casing 1a. Therefore, the operator key 38 cannot be used to open the ceiling of the bill storing stacker 10 before the stacker 10 has been put in setting position 37 in the money collecting machine. When the bill storing stacker 10 has been set in position, and when the operator key 38 is used to lower the front latch bolt 42, the bottom end 42b of the front latch bolt 42 falls into the catch hole 41, thus preventing withdrawal of the bill storing stacker 10 out of the money collecting machine casing. In order to permit withdrawal of the bill storing stacker 10 out of the money collecting machine casing it is necessary to use the operator key to raise the front latch bolt 42. If the ceiling board 32 is withdrawn to open the ceiling of the stacker 10 as shown in Fig. 18, the rise of the front latch bolt 42 is prevented; the tip end 42a of the front latch bolt 42 would strike against the lower surface of the ceiling board 32. Thus, the stacker 10 with its ceiling open cannot be taken out of the money collecting machine casing 1a.

When the bill storing stacker 10 has been loaded with bills to its full capacity, the magnet 69 on the lower surface of the bill-supporting plate 67 is

lowered to the level at which the magnet detecting sensor 70 is positioned, thus informing that the stacker 10 has been filled with bills. Then, or periodically the bill storing stacker 10 is taken out of the money collecting machine casing for collection of stored money. The stacker 10 cannot be taken out without closing the ceiling opening with the ceiling board 32, and therefore nobody can have access to the bills 4 stored in the stacker.

When the bill storing stacker 10 is taken out of the money collecting machine casing 1a, the ceiling board 32 has been pushed into the closing position, and then the ceiling board 32 has been locked with the rear panel 33; the rear latch bolt 44 of the rear panel is caught by the catch hook 49 of the ceiling board. The operator key 38 cannot be used in this position. However, even if the operator key 38 should be able to be used to to lower the front latch bolt 42, the ceiling board 32 which is locked with the rear panel 33, cannot be withdrawn to open the ceiling. Thus, prevention of access to the stored money will be doubly insured.

When it is desired that the stored maney is taken out of the money storing stacker 10, the manager inserts his key 50 into the key hole 48 on the rear

panel 33 to turn in as indicated by arrow 75 in Fig. 20, thereby lowering the rear latch bolt 44. Then, the rear panel 33 is ready to open.

After the money is taken out, the rear panel 33 is raised with its rear latch bolt 44 rising upward, and is pushed against the stacker casing to lock the rear panel 33. Then, as shown in Fig. 14 the tip end 44a of the rear latch bolt 44 strikes against the lower surface of the spring-biased catch hook 49, which has turned in the disengaged position as shown in Fig. 14. Therefore, subsequent withdrawal of the ceiling board 32 from the ceiling of the stacker casing will not be hindered.

As described above, a money storing stacker 10 for storing bills 4 therein is designed to have a ceiling board 32 slidable along the ceiling of the stacker casing, and is designed to removably set in the money collecting machine casing 1a. In use it is necessary to set the stacker 10 in right position 37, and the ceiling board 32 is withdrawn to its fullest length; otherwise the money collecting machine 1 cannot work. The operator must confirm that the money collecting machine 1 has been put in working condition after setting the stacker 10 and withdrawing the ceiling board 32. In an attempt to permit necessary

confirmation by sight there are provided a microswitch MS and a magnet-and-sensor combination. After the stacker 10 has been set in the right position 37, the operator uses an operator key 38 to lower the front latch bolt 42. Then, in response to the descent and push by the front latch bolt 42 to the switch contact MSa the switch MS will turn on.

When the ceiling board 32 has been withdrawn to its full length, the magnet M fixed to the rear end of the ceiling board 32 will come close to the cover sensor CS to cause the sensor to turn on. The microswitch MS and the cover sensor CS are series-connected to the controller 8, and the controller 8 is responsive to turning-on of both of the microswitch and the sensor for lighting an associated indication lamp 76 on the money collecting machining casing 1a. Thus, the operator can confirm by sight that the money collecting machine has been put in working condition.

The embodiment of the present invention had been described as collecting bills 4. It, however, should be understood that the money collecting machine can be applied to collection of coins by using a chute in place of the belt conveyor system 9.

The ceiling of the bill storing stacker 10 has upper and lower rails 62 and 63 to define a space for

accomodating the ceiling board 32. The lower railles define an opening whose width is narrower than the width of bill, thereby preventing bills 4 coming up above the lower rail 63 in the way in which the ceiling board 32 travels, thereby preventing the way to be jammed with bills.

In this particular embodiment the microswitch MS and the cover sensor CS are series-connected, and a single indication lamp 76 is used. When both of microswitch MS and cover sensor CS turn on, the lamp 76 is lit. As a matter of course two indication lamps may be allotted to the microswitch MS and the cover sensor CS respectively.

Claims:

1. A money collecting machine appropriate for incorporating in a money exchanger, a ticket selling machine, an automatic vending machine etc, comprising: in a casing, a bill slot; a bill detector for making a decision as to whether the bill thrown into the bill slot is genuine or false, and what kind of bill it is, said bill detector being capable of sending a drive signal such as an instruction signal for permitting the exchange of money, and being capable of returning the bill to the bill slot upon resumption of the electric power supply subsequent to a power outage; and a bill transporting unit for transporting bills from the outlet of the bill detector to a bill storing stacker, said bill transporting unit 9 comprising a pair of upper and lower conveyors 11a and 11b laid on each other, thereby sandwiching bills 4 therebetween, each conveyor 11a or 11b comprising a front shaft 12 or 13 on the upstream side as viewed in the direction in which bills 4 are to be travelled, a front pulley group 17 or 18 made up by a plurality of pulleys 16 fixed to the front shaft 12 or 13 at predetermined intervals, a rear shaft 14 or 15 on the downstream side, a rear pulley group 19 or 20 made up by a plurality of pulleys 16

fixed to the rear shaft 14 or 15 at predetermined intervals, endless belts 21 connecting the pulleys of the front and rear pulley groups, a gear wheel 26 fixed to either of the front or rear shafts 12, 13 or 14, 15, the gear wheels 26 and 26 of the upper and lower conveyors being engaged, via pinion gears 27, 27, with a driving gear wheel 23b fixed to the shaft 23a of a motor 22; a clutch 23 interconnecting the motor shaft 23a and the gear wheels 26 and 26, and being responsive to a disconnection signal "n2" for disconnecting the gear wheels 26 and 26 from the motor shaft 23a, which disconnection signal "n2" is generated by a control 8 in case that a bill remains partly in the bill detector 5 upon resumption of the electric power supply subsequent to a power outage, and said the clutch 23 being responsive to a connection signal "n1" for connecting the gear wheels 26 and 26 with the motor shaft 23a, which connection signal "n1" is generated by the control 8 a predetermined time after receipt of the disconnection signal by the clutch 23, each of the rear shafts of the upper and lower conveyors 11a and 11b having a plurality of rolls 24 of such a diameter that their circumferences project somewhat beyond the bill-conveying plane 25 in which the upper and lower conveyor belts oppose to each other, the rolls 24 of

the rear shaft of the upper conveyor 14 being staggered with the rolles 24 of the rear shaft of the lower conveyor 15.

2. A money collecting machine appropriate for incorporating in a money exchanger, a ticket selling machine, an automatic vending machine etc, comprsing: in a casing, a bill slot: a bill detector for making a decision as to whether the bill thrown into the bill slot is genuine or false, and what kind of bill it is, said bill detector being capable of sending a drive signal such as an instruction signal for permitting the exchange of money, and being capable of returning the bill to the bill slot upon resumption of the electric power supply subsequent to a power outage; and a bill transporting unit for transporting bills from the outlet of the bill detector to a bill storing stacker, said bill transporting unit 9 comprising a pair of upper and lower conveyors 11a and 11b laid on each other, thereby sandwiching bills 4 therebetween, each conveyor 11a or 11b comprising a front shaft 12 or 13 on the upstream side as viewd in the direction in which bills 4 are to be travelled, a front pulley group 17 or 18 made up by a plurality of pulleys 16 fixed to the front shaft 12 or 13 at predetermined intervals, a rear

shaft 14 or 15 on the downstream side, a rear pulley group 19 or 20 made up by a plurality of pulleys 16 fixed to the rear shaft 14 or 15 at predetermined intervals, endless belts 21 connecting the pulleys of the front and rear pulley groups, a gear wheel 26 fixed to either of the front or rear shafts 12, 13 or 14, 15, the gear wheels 26 and 26 of the upper and lower conveyors being engaged, via pinion gears 27, 27, with a driving gear wheel 23b fixed to the shaft 23a of a motor 22; a clutch 23 interconnecting the motor shaft 23a and the gear wheels 26 and 26, and being responsive to a disconnection signal "n2" for disconnecting the gear wheels 26 and 26 from the motor shaft 23a, which disconnection signal "n2" is generated by a control 8 in case that a bill remains partly in the bill detector 5 upon resumption of the electric power supply subsequent to a power outage, and said the clutch 23 being responsive to a connection signal "n1" for connecting the gear wheels 26 and 26 with the motor shaft 23a, which connection signal "n1" is generated by the control 8 a predetermined time after receipt of the disconnection signal by the clutch 23, each of the rear shafts of the upper and lower conveyors 11a and 11b having a plurality of rolls 24 of such a diameter that their circumferences project somewhat beyond the bill-

conveying plane 25 in which the upper and lower conveyor belts oppose to each other, the rollers 24 of the rear shaft of the upper conveyor 14 being staggered with the rollers 24 of the rear shaft of the lower conveyor 15, and said bill storing stacker comprising: a bill storing stacker 10 which is modified according to the present invention as follows: the stacker 10 comprises a stacker casing 31 having openings in its ceiling 29 and rear side 30, a ceiling board 32 which is adapted to open and close the ceiling opening, a rear board 33 which is adapted to open and close the rear opening, a front latch bolt 42 movably fixed to the back of the front panel of the stacker casing 31, the front latch bolt 42 being adapted to descend, leave from a catch hole 39 made in the back of the ceiling board 32 and fall in a catch hole 41 made in the bottom panel 40 of the casing 1a of the money collecting machine by using an operator key, thereby enabling the stacker to be put in its opening position after having put the stacker 10 in right position in the casing 1a of the money collecting machine, and the front latch bolt 42 being adapted to rise, leave the catch hole 41 made in the bottom panel 40 of the casing 1a of the money collecting machine, and enter the catch hole 39 made in the ceiling panel 32 by using the operator key,

thereby putting the stacker in its closing position; and said money collecting machine further comprising; a micro switch MS responsive to the descent of the latch bolt 42 into the lower catch hole 41 in the bottom panel of the casing 1a of the money collecting machine, for lighting an indication lamp 76, thereby permitting the operator to confirm that the stacker has been put in right position; a magnet M fixed to the rear, side edge of the ceiling board 32 and a cover sensor CS fixed to the casing 1a of the money collecting machine at such a position that the sensor CS may detect the magnetic force from the magnet M when the ceiling board has been drawn to its full length, thereby lighting an indication lamp 76 and permitting the operator to confirm that the ceiling board 32 has been drawn to its full length ; and a rear latch bolt 44 movably fixed to the back of the rear hinged panel 33 of the stacker casing 31, the rear latch bolt 44 being adapted to descend, leave the notch 53 of a catch hook 49 when a person in charge, or manager uses a manager key for putting the rear panel in its opening position, the catch hook being rotatably fixed to the back of the ceiling board, and being spring-biased to keep its notch 53 in engagement with the rear latch bolt 44 by a spring 54, but being adapted to turn to its disengaged

position by the spring 54 once the rear lanch bolt 44 has been released from the catch hook 49 for opening the rear panel 33, in the disengaged position the catch hook 49 preventing the rise of the rear latch bolt 44 by causing the tip end 44a of the rear latch bolt 44 to strike against the lower surfase 49' of the catch hook 49; the hinged rear board 33 being adapted to be locked to the stacker casing by pushing the ceiling board 32 to close the ceiling opening, then causing the rear latch bolt 44 to strike against the guide slope 52 of the catch hook 49 to rotate the catch hook 49 and permit the rear latch bolt 44 to snap in the north 53 of the catch hook 49; and the operator key being connected to the casing of the money collecting machine with a chain 46 the length of which is adequate to permit the operator to use the operator key only when the bill storing stacker 10 has been put in right position 37 in the casing 1a of the money collecting machine casing 1a.

3. A money collecting machine according to claim 1 or 2 wherein it further comprises a guide means positioned ahead of the exit of the money transporting unit 9 just above the money storing stacker 10, said guide means comprising: two opposing beams 56, 56, guide

support pieces 57, 57 fixed to the opposing beams, swingable pieces 60, 60 vertically movably and swingably attached to the guide support pieces 57, 57 by inserting stad pins 59, 59 in the longitudinal slots of the swingable pieces 60, 60, thus permitting the swingable pieces 60, 60 swing and vertically move at the time of installation and removal of the money storing stacker 10 in and out of the casing of the money collecting machine and at the time of closing and opening the ceiling board 32, the guide means functioning to guide the bills from the exit of the money transporting unit 9 to right position above the money storing stacker 10 in good order.

F I G . 1

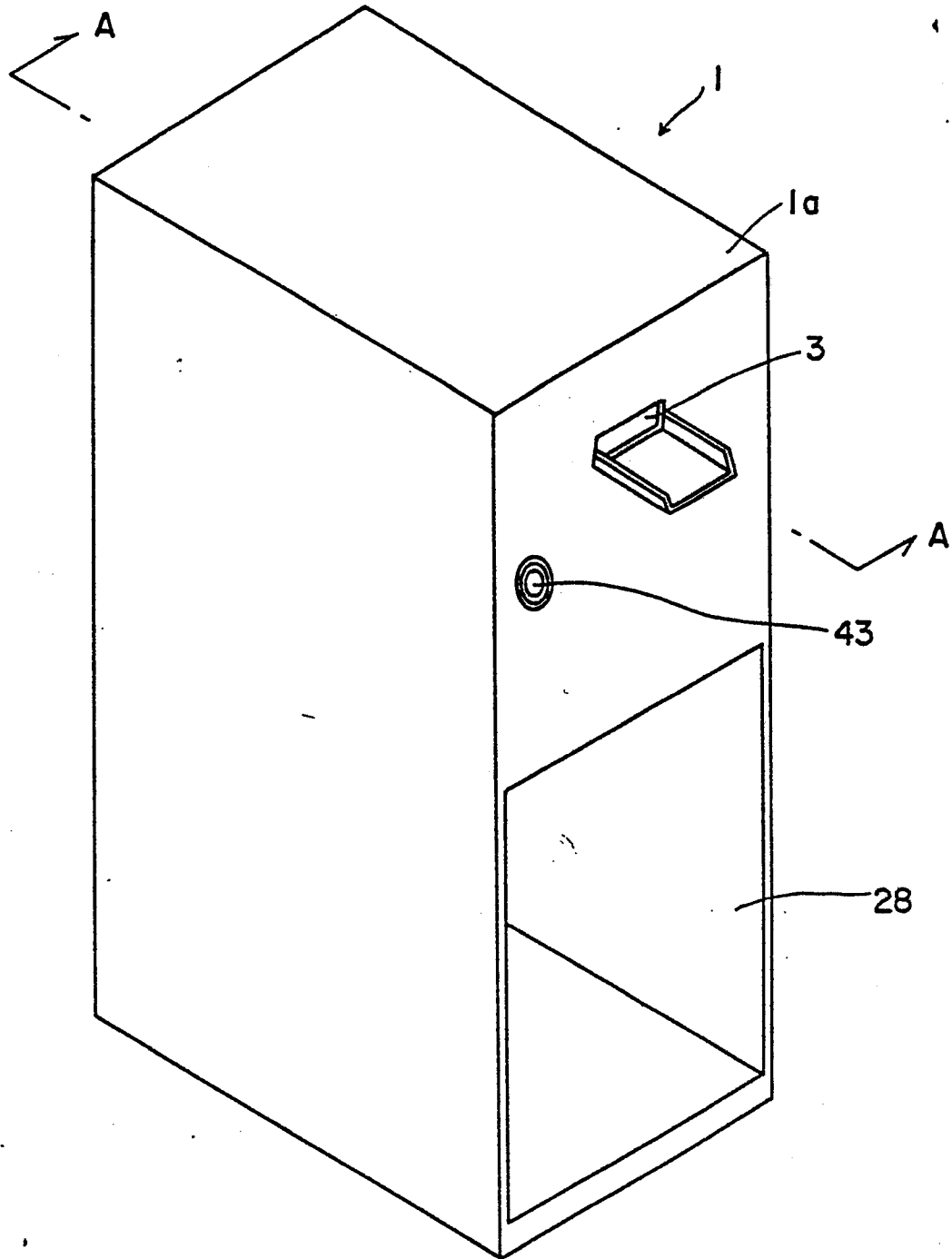

FIG. 2

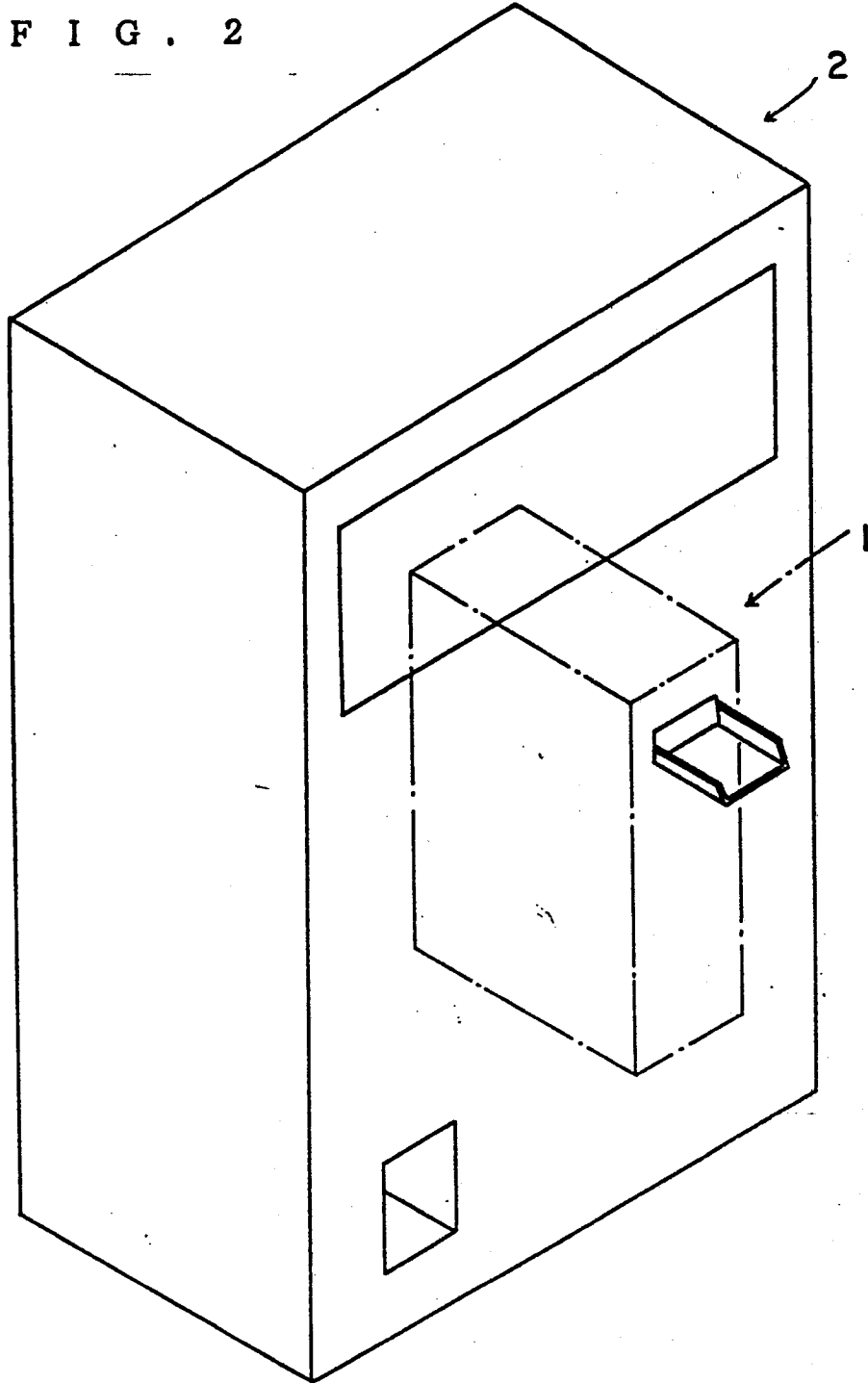
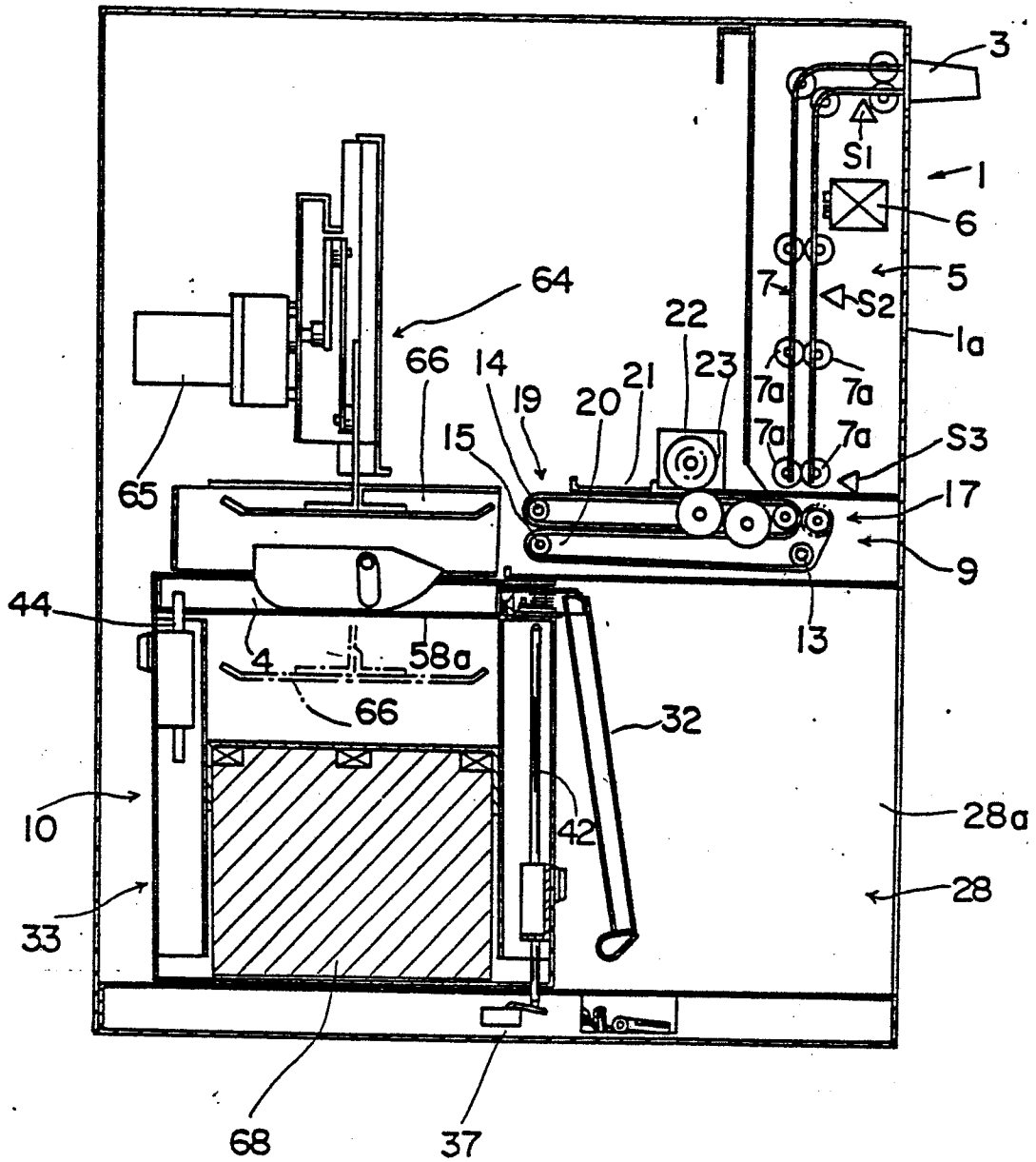
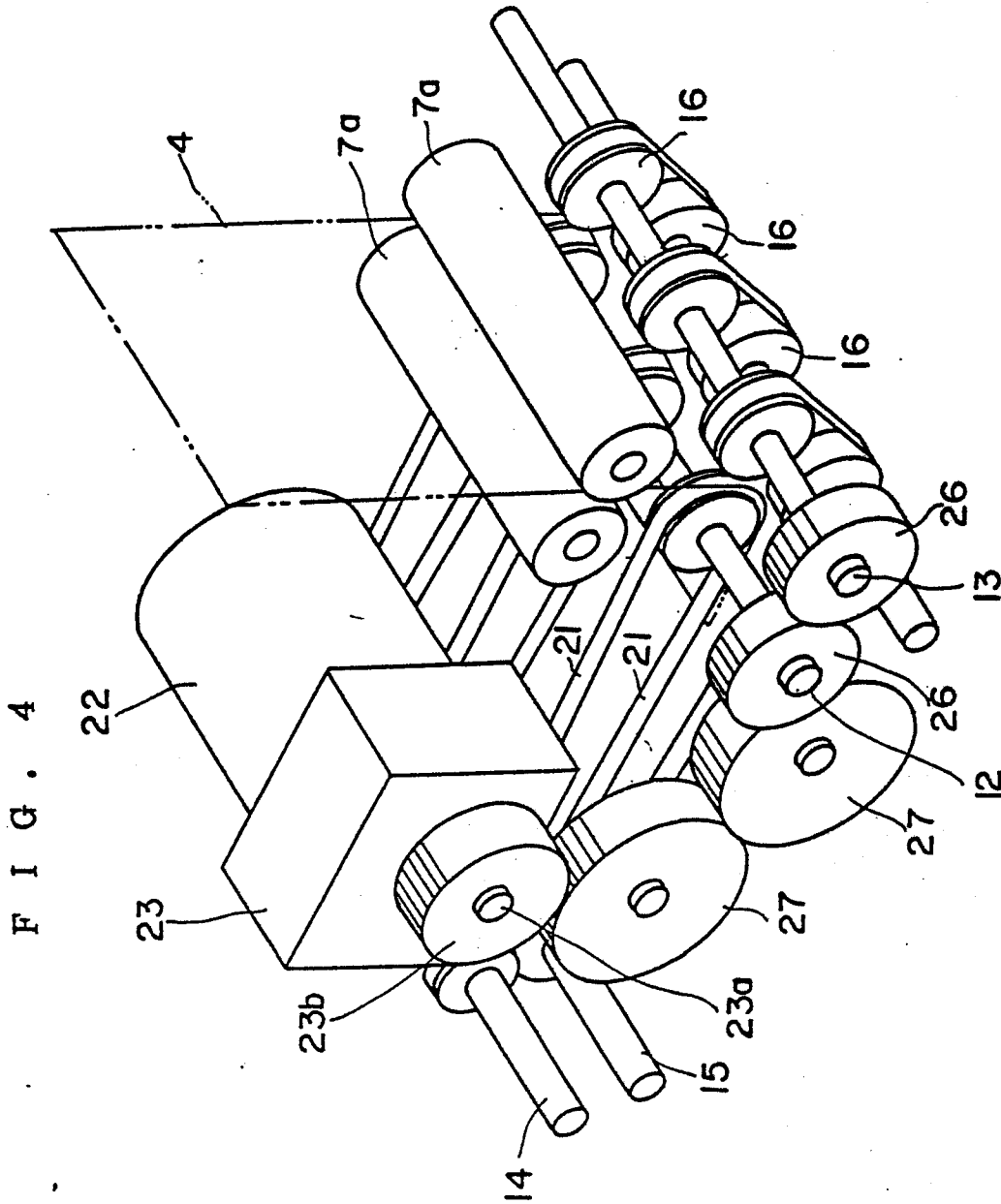

FIG. 3





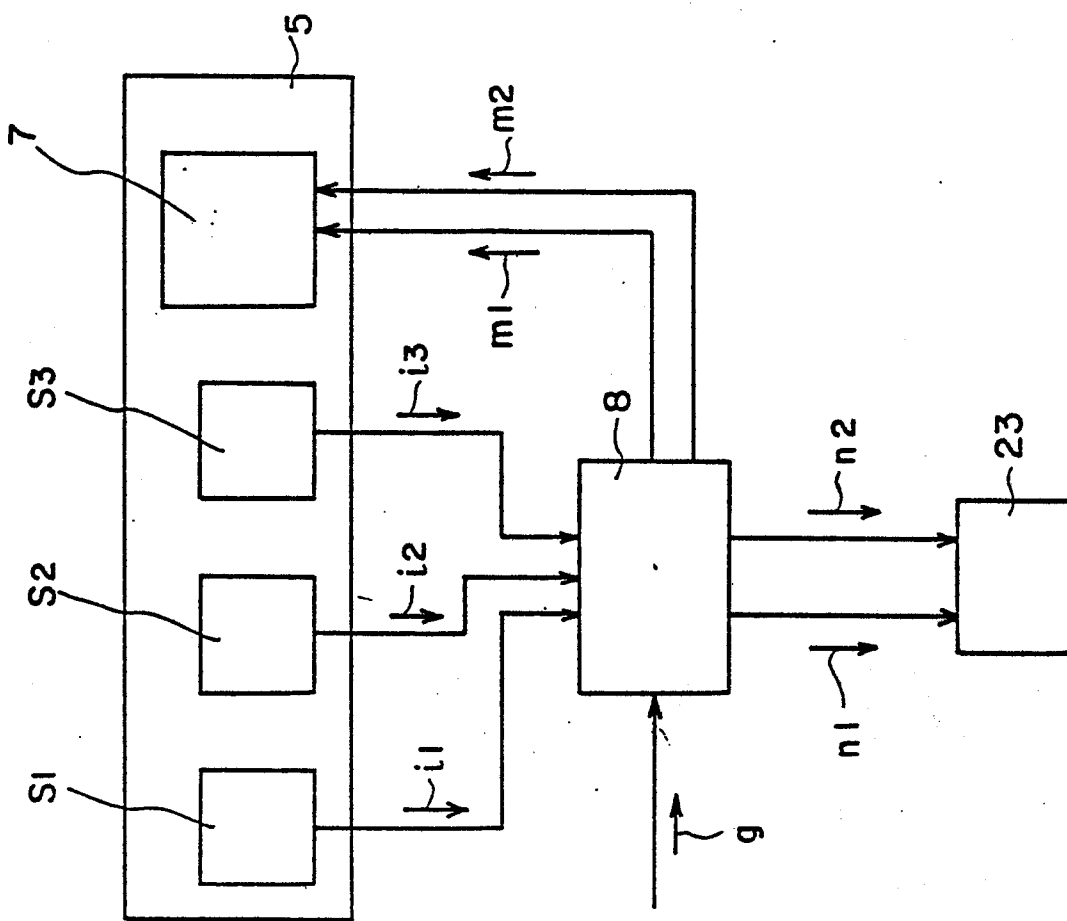
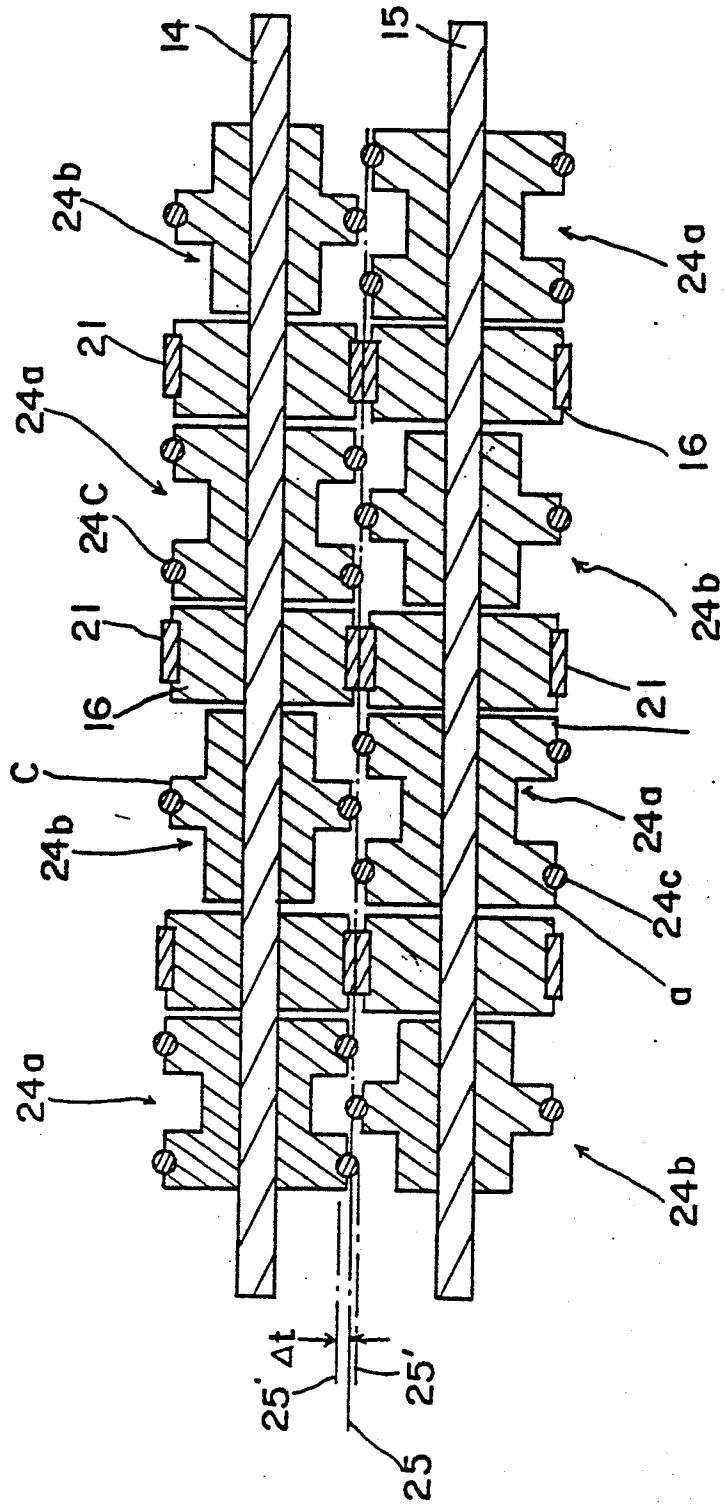

FIG. 5



FIG. 8



F I G . 9

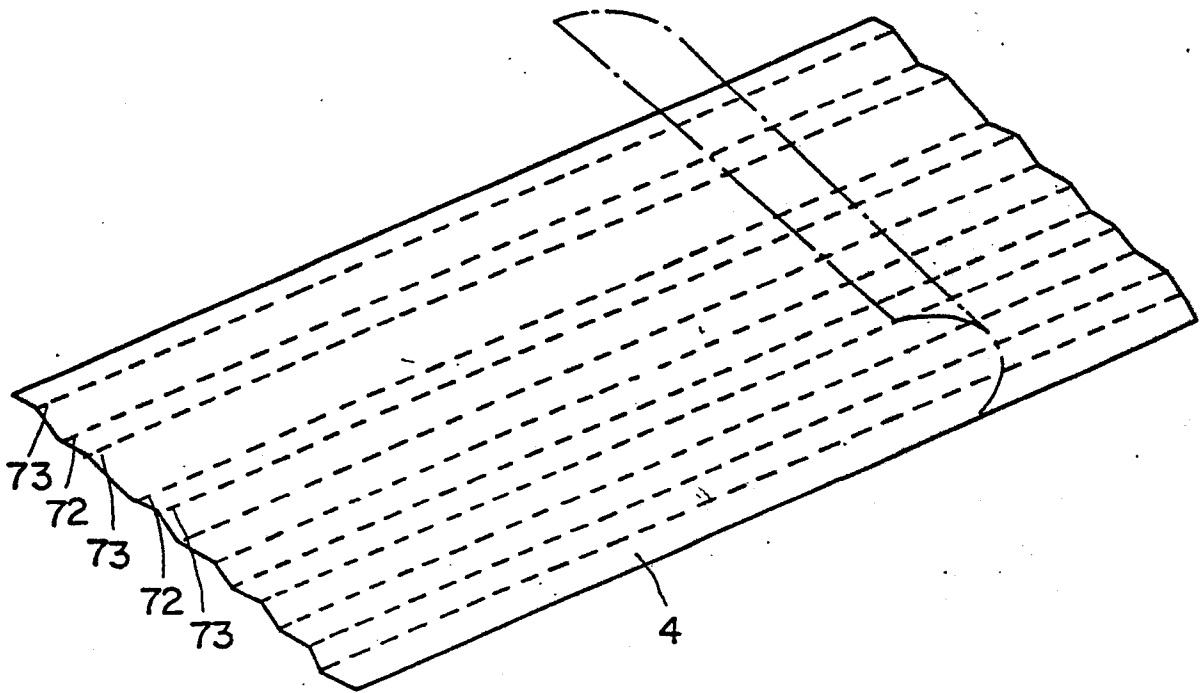
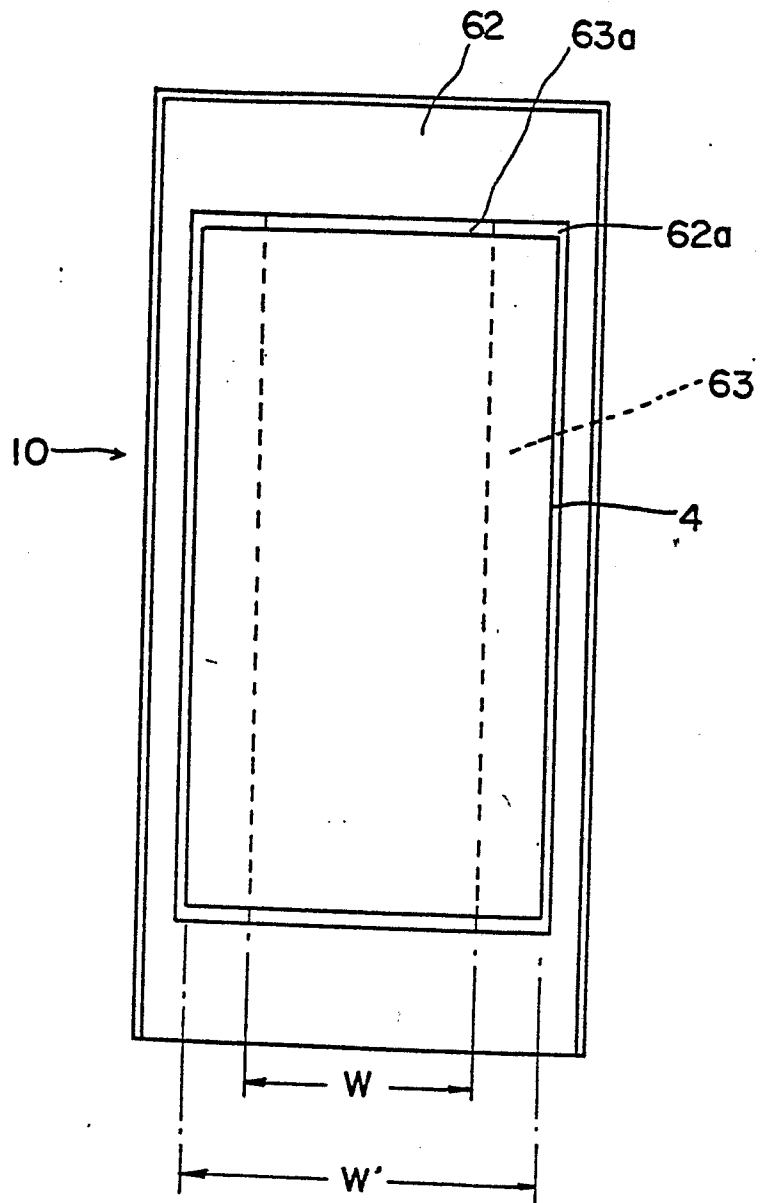

FIG. 10



F I G . 1 1

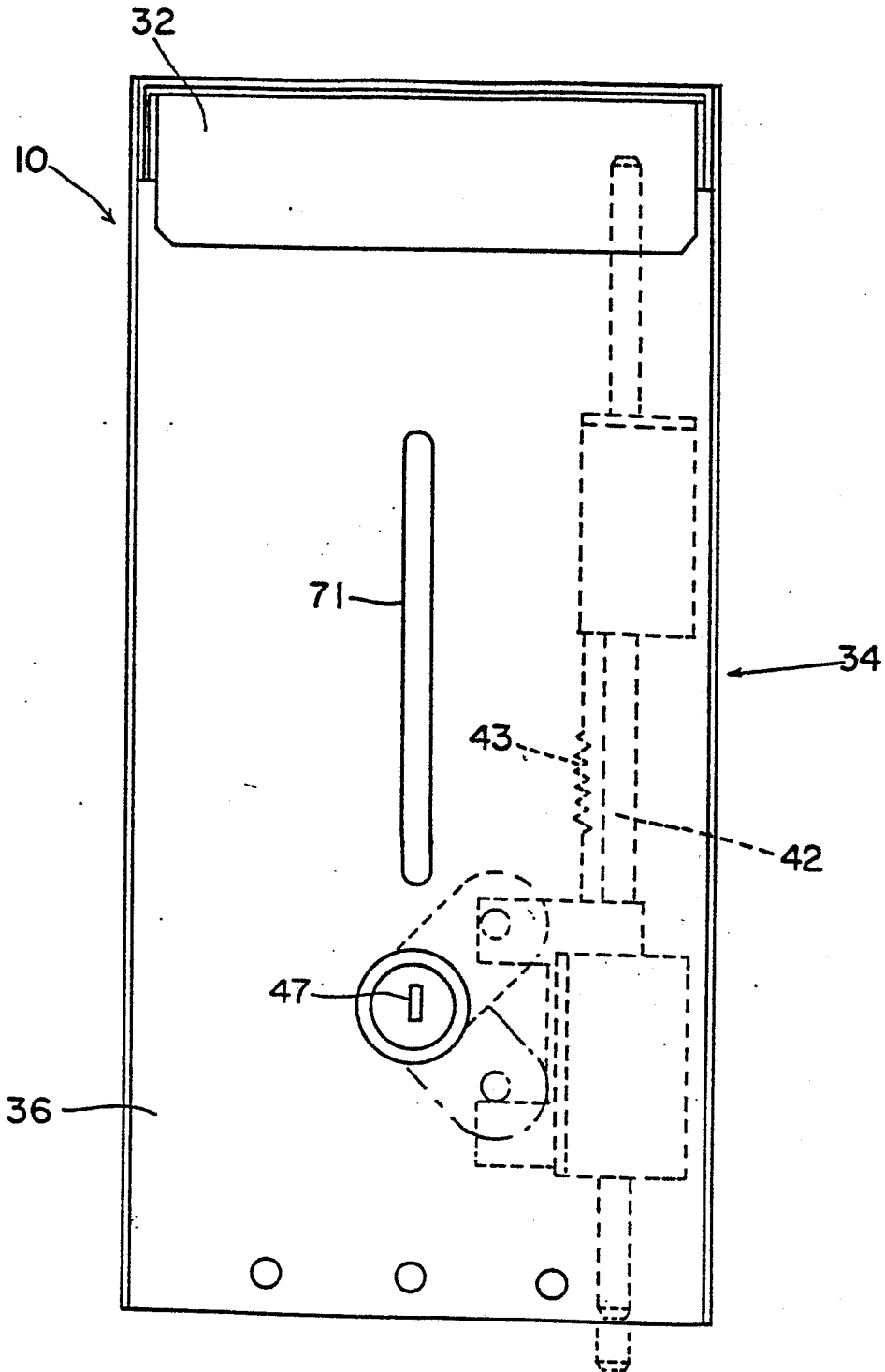

FIG. 1-2

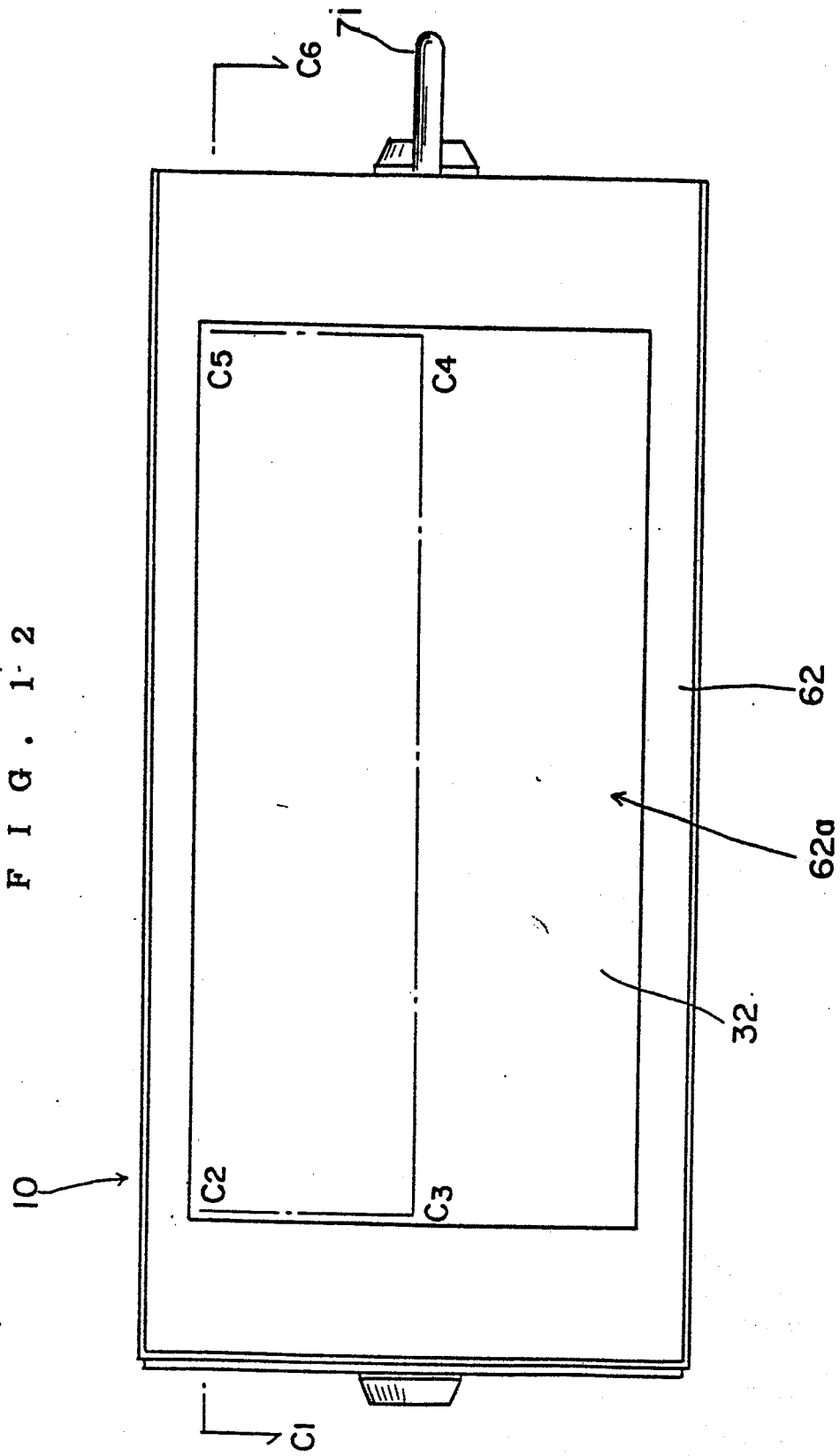

FIG. 13

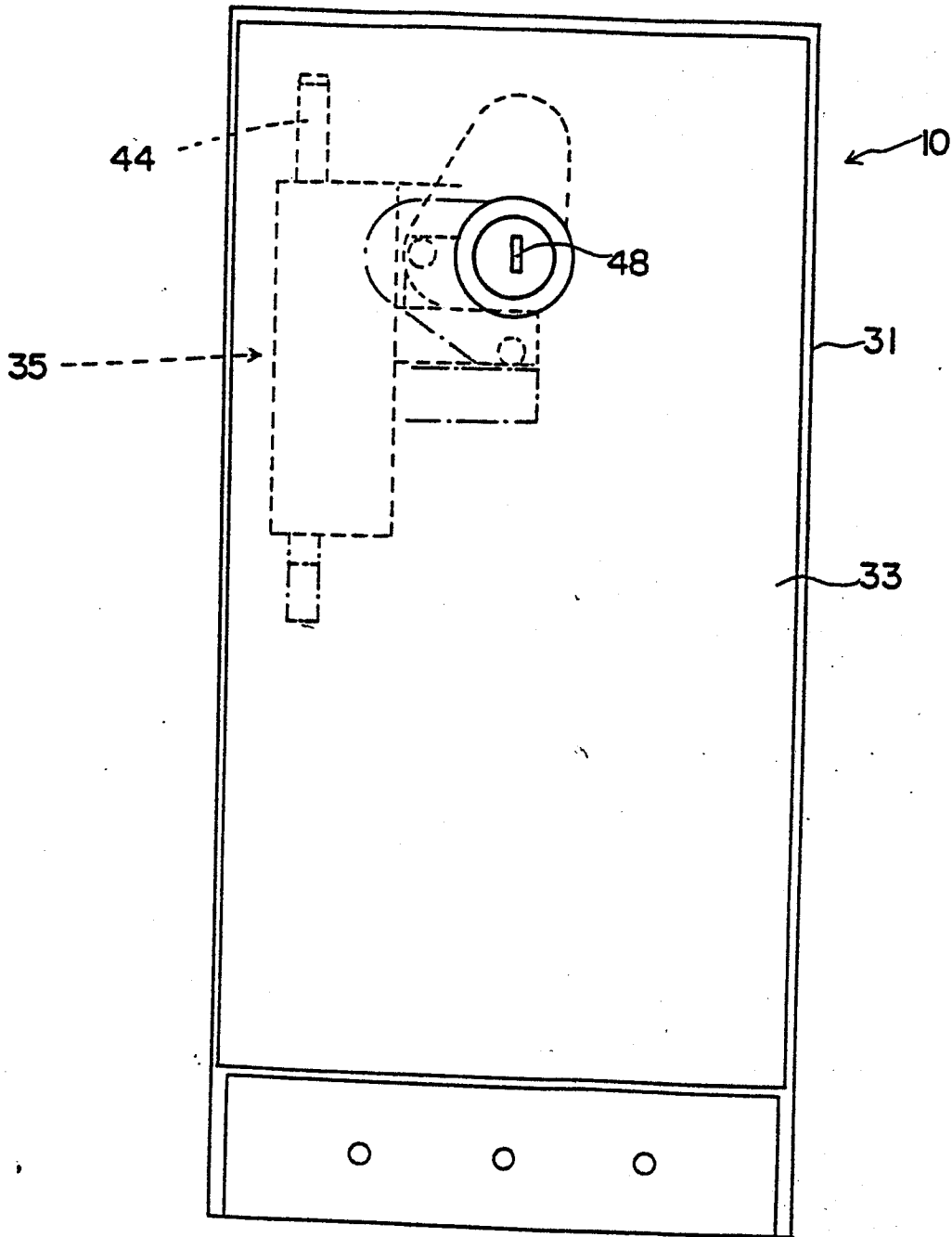

FIG. 14

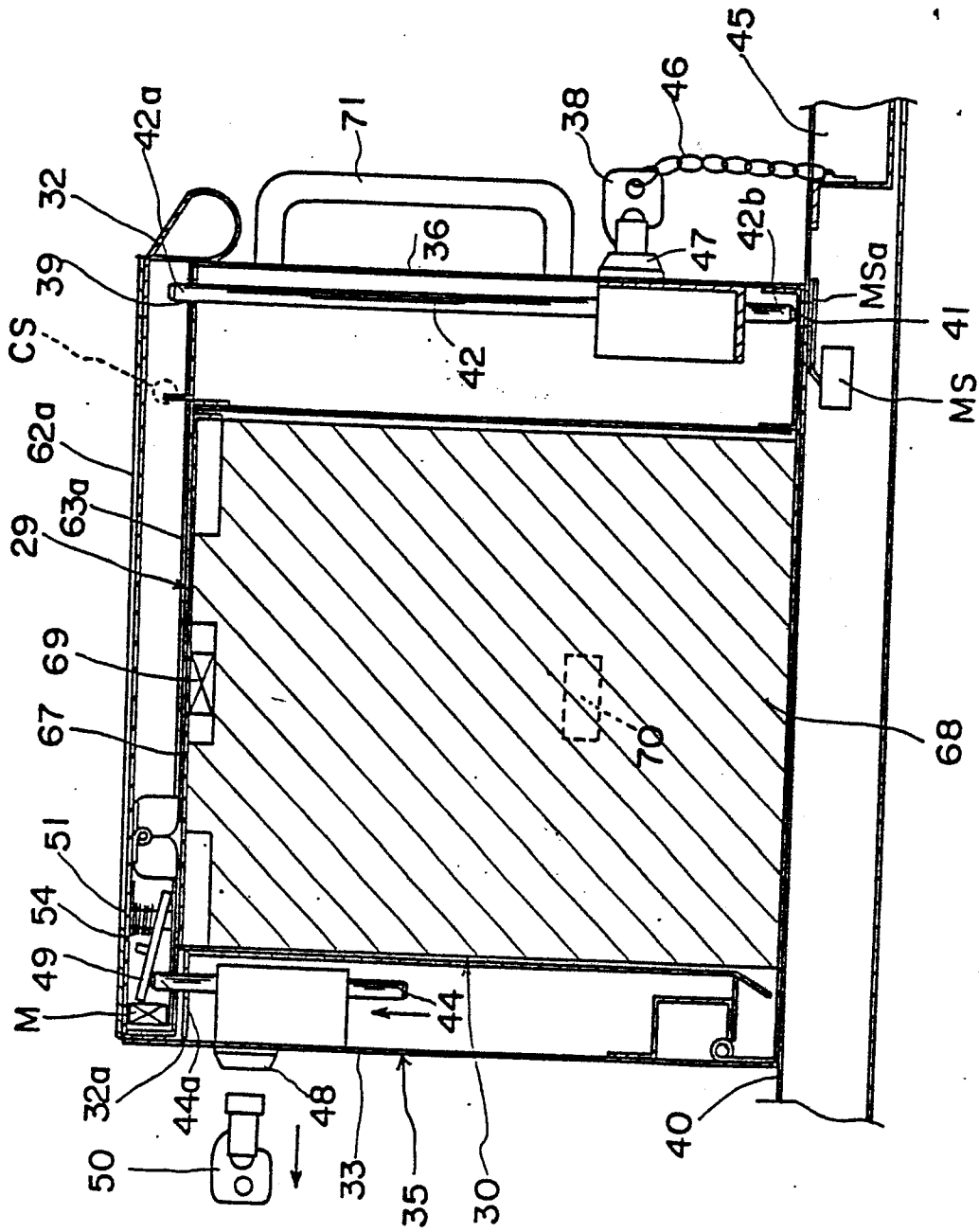

FIG. 15

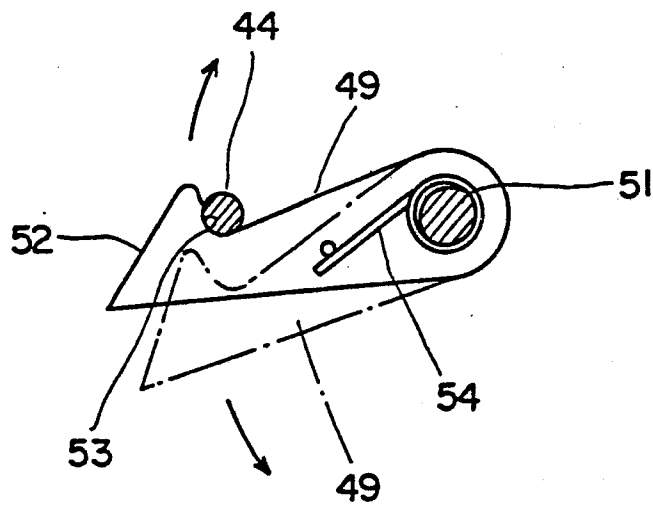

FIG. 16

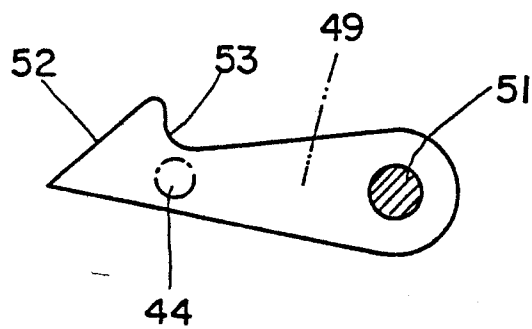

FIG. 17

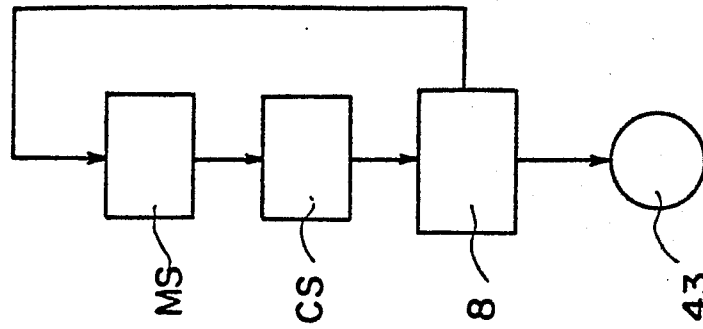

FIG. 18

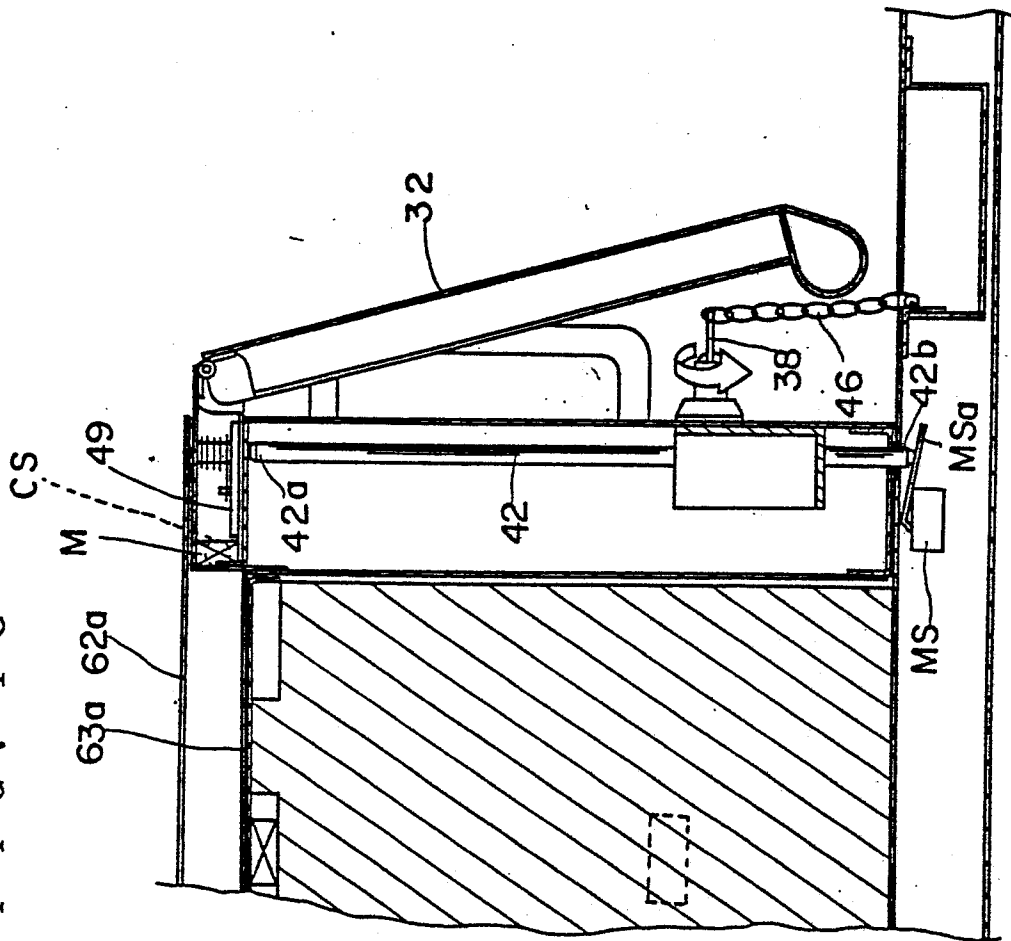
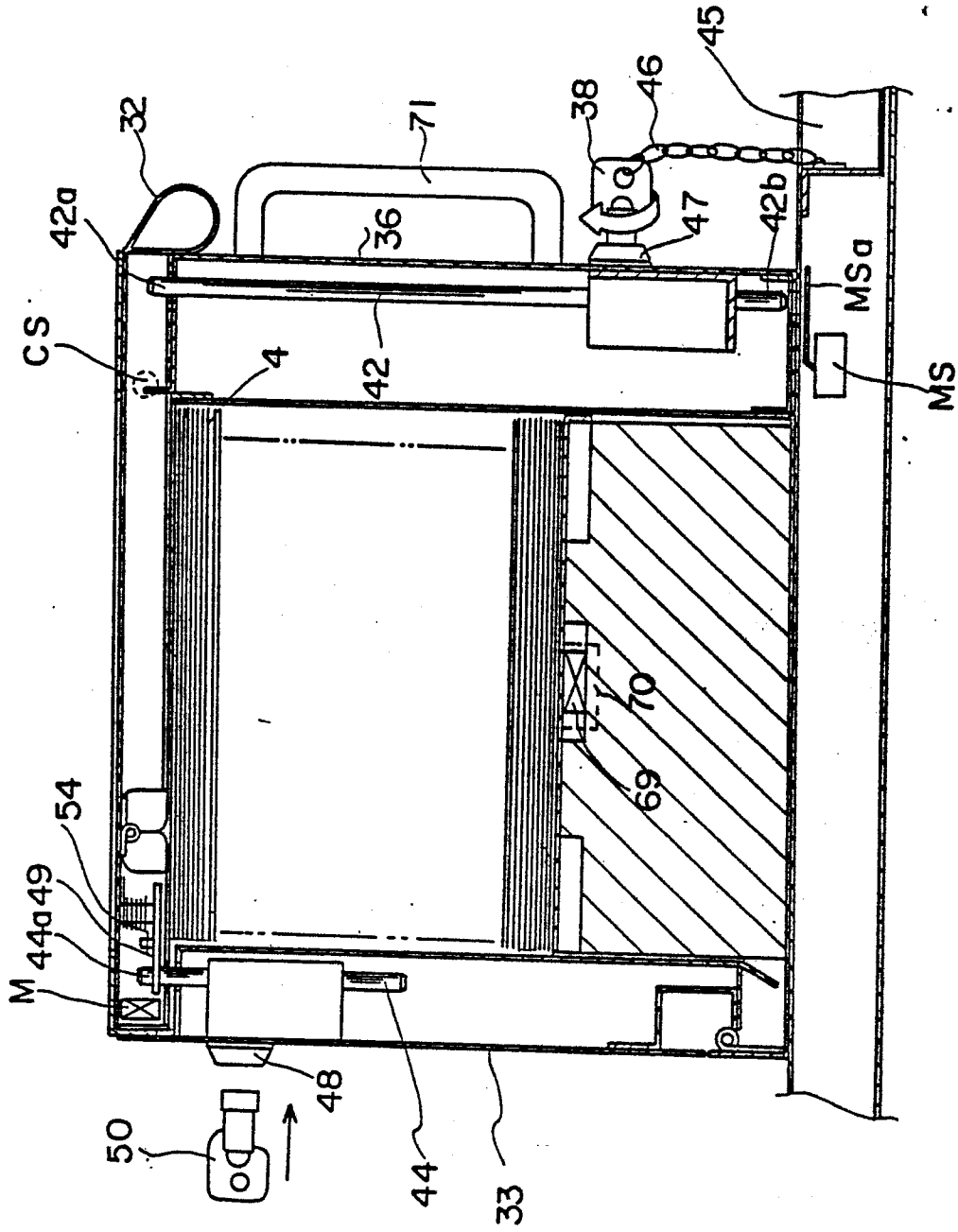

FIG. 19



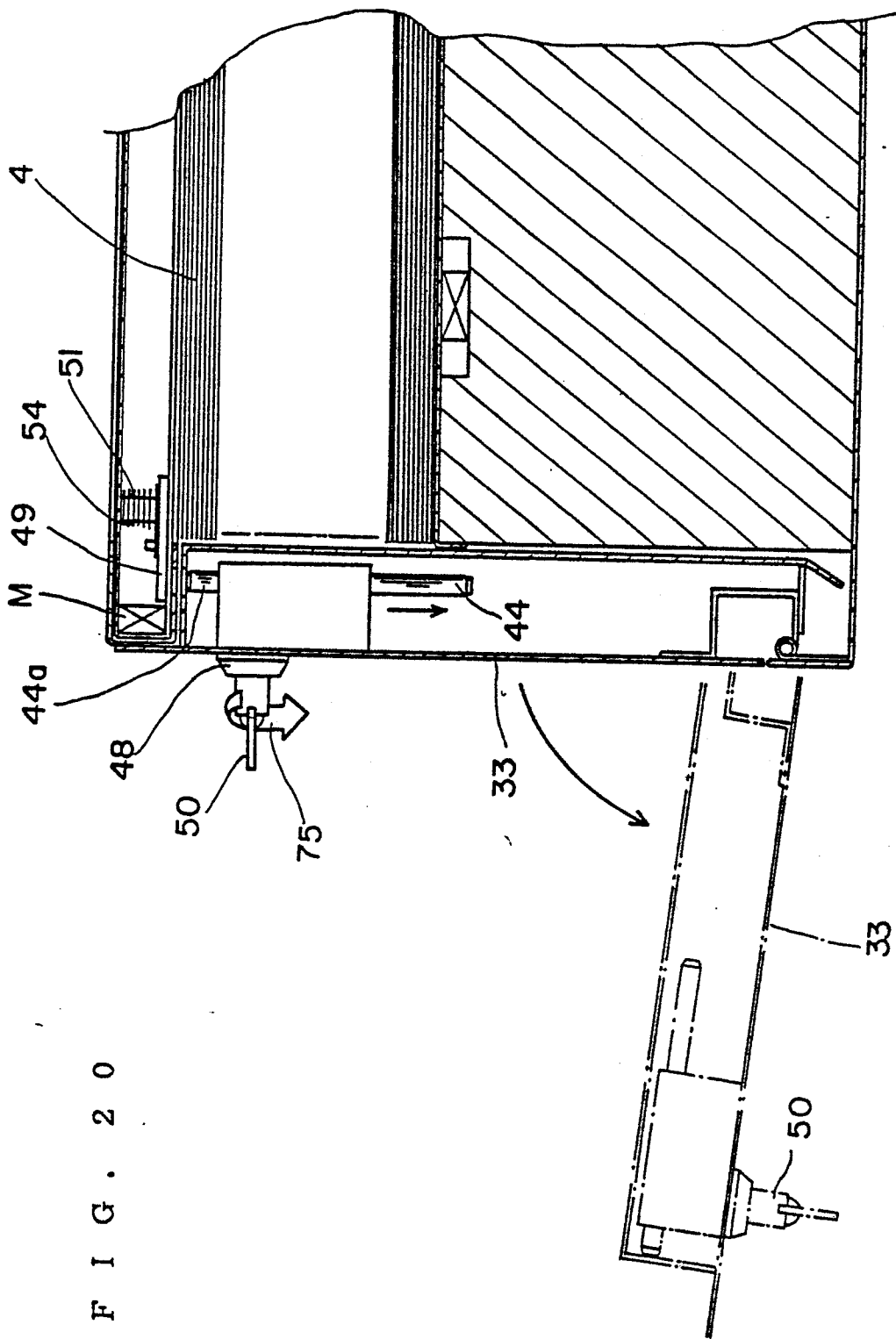
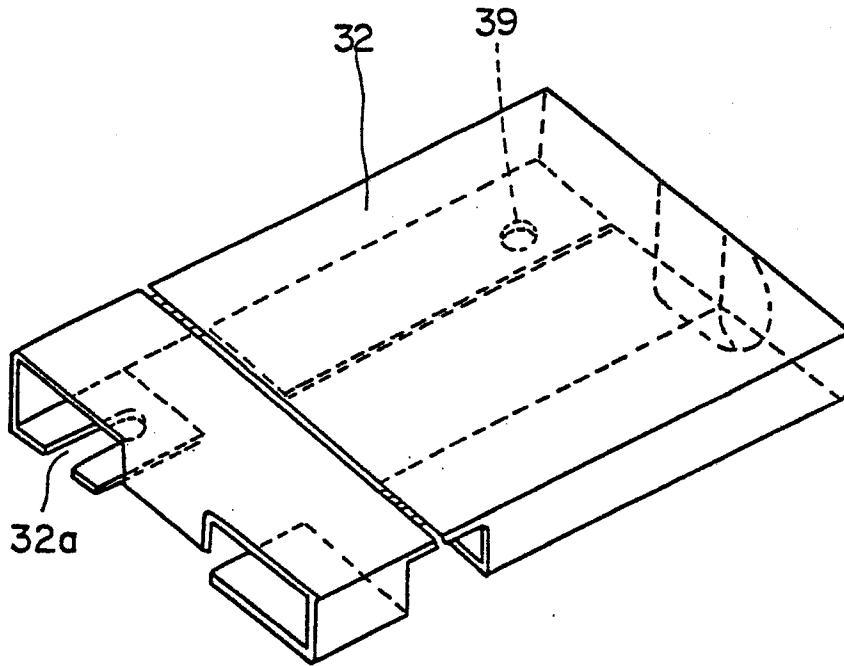

FIG. 20

F I G . 2 1



F I G . 2 2

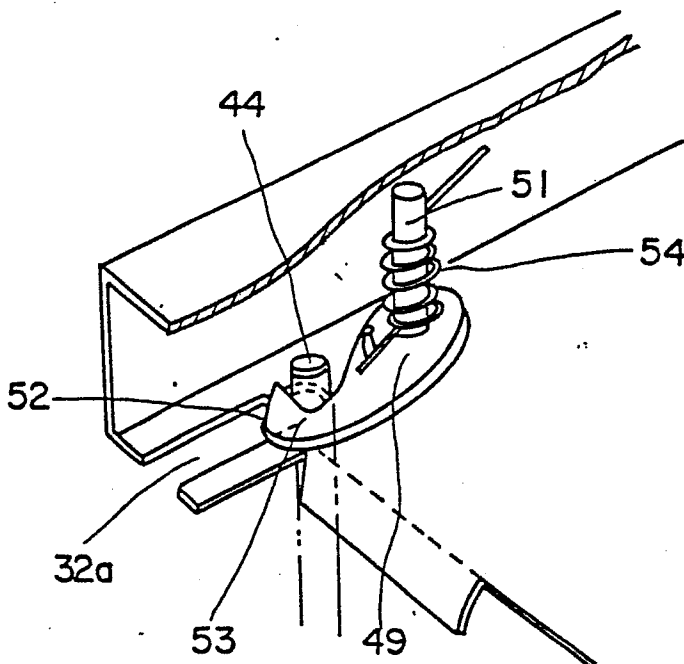

FIG. 23

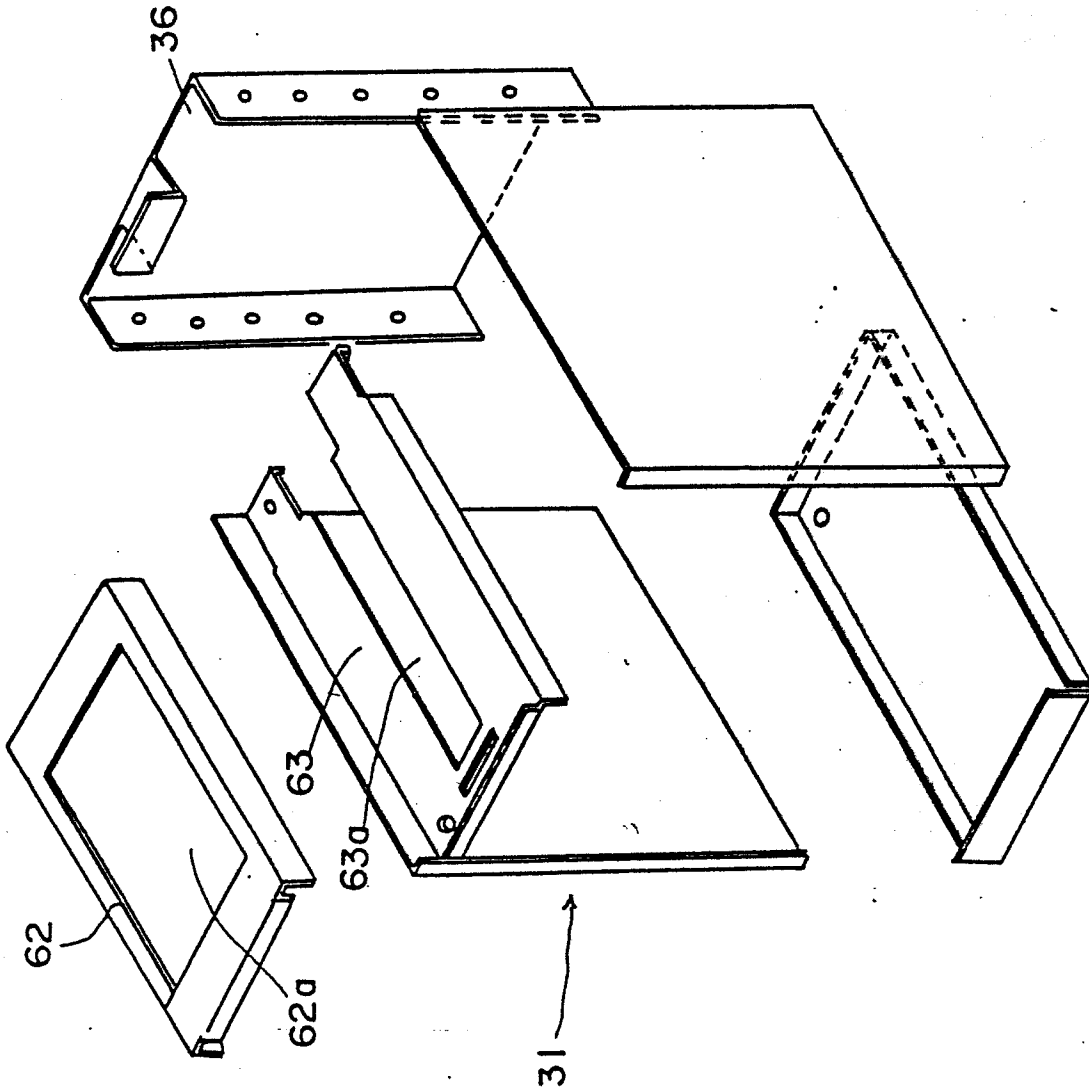

FIG. 24

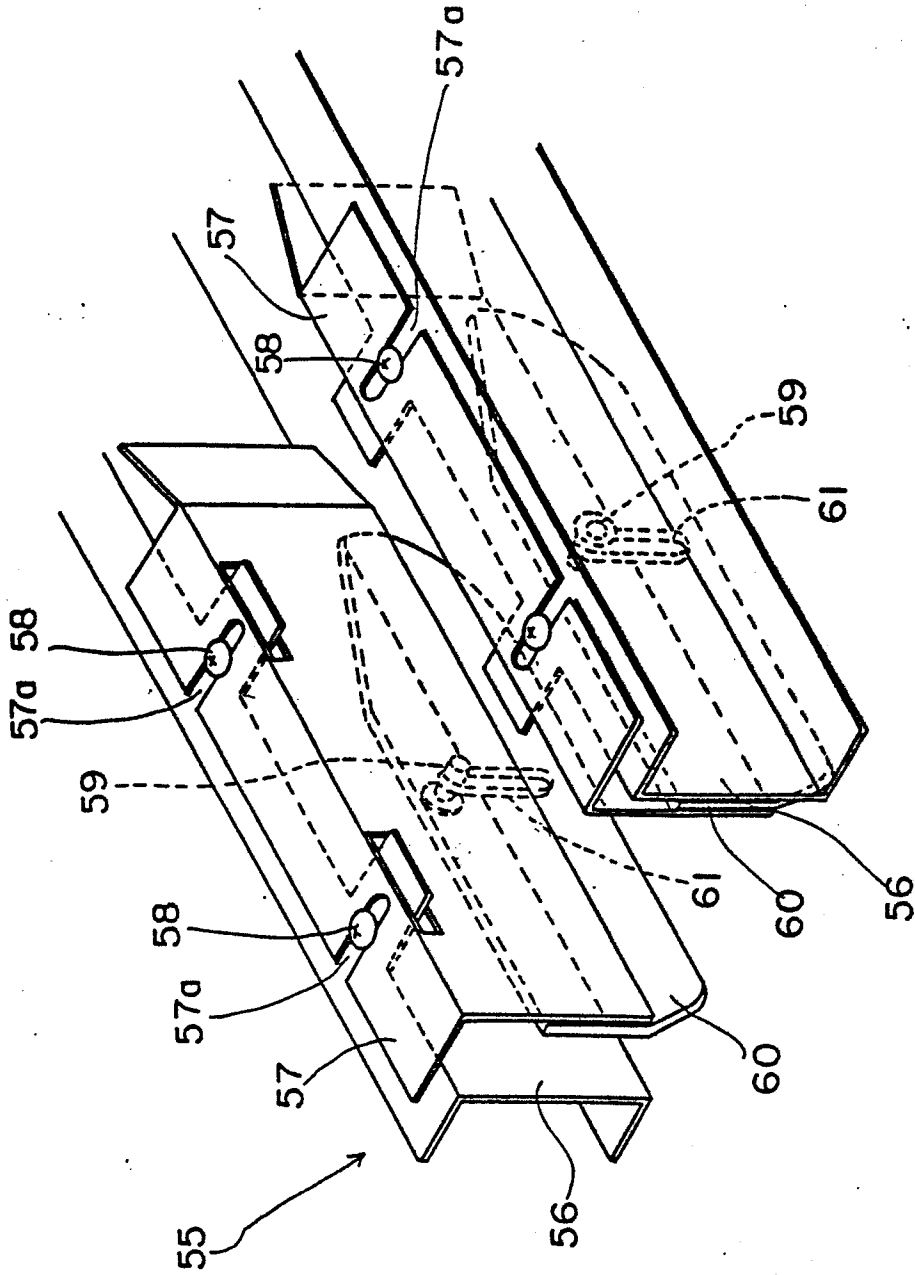

FIG. 25

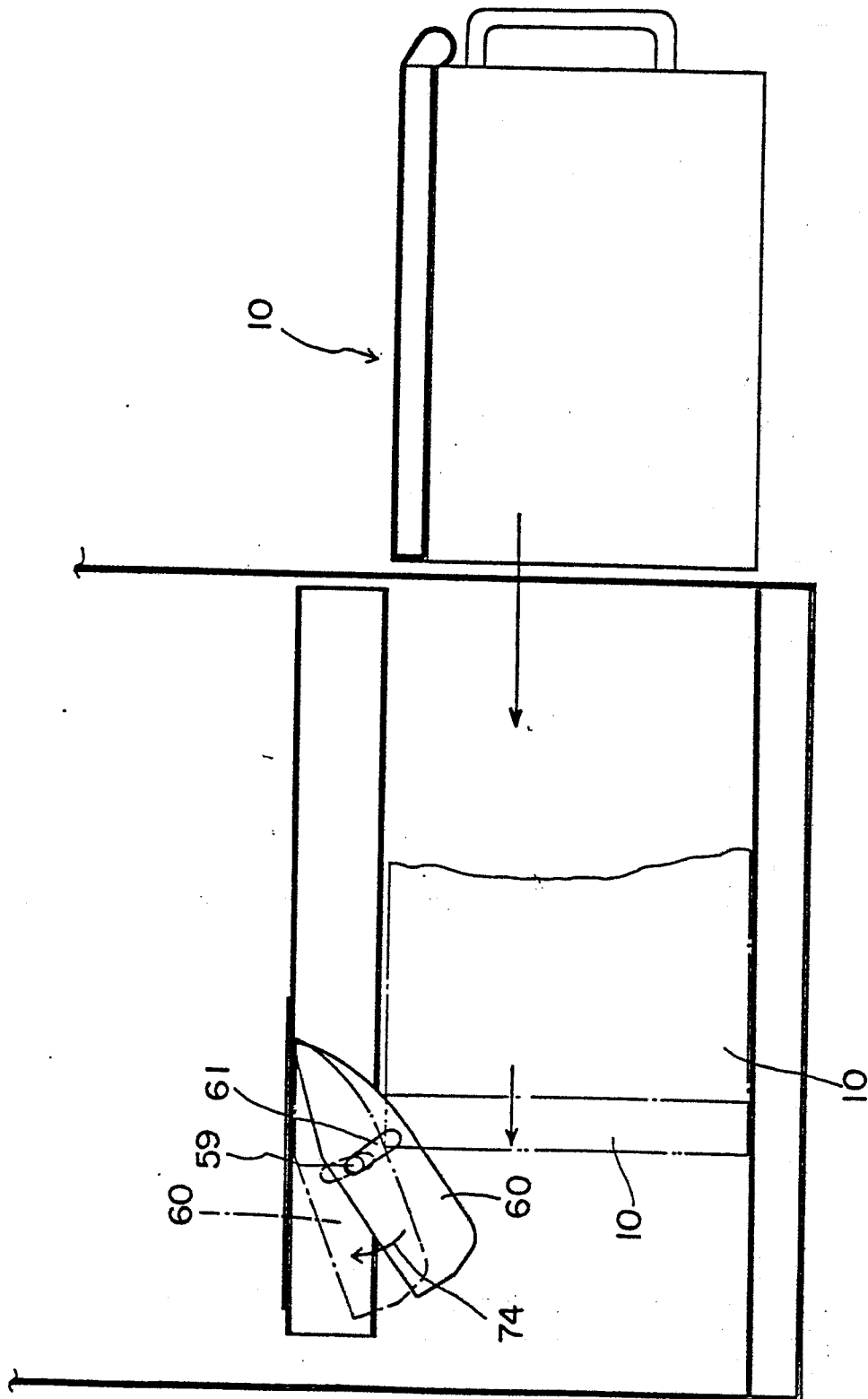

FIG. 26

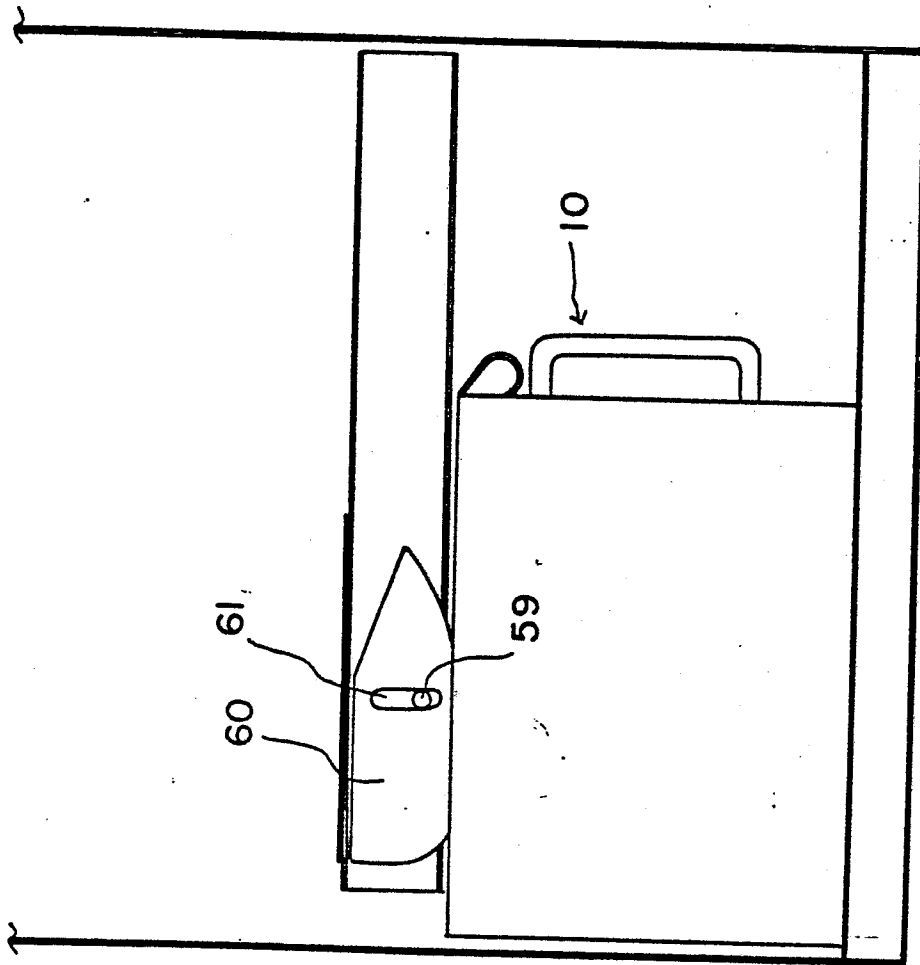
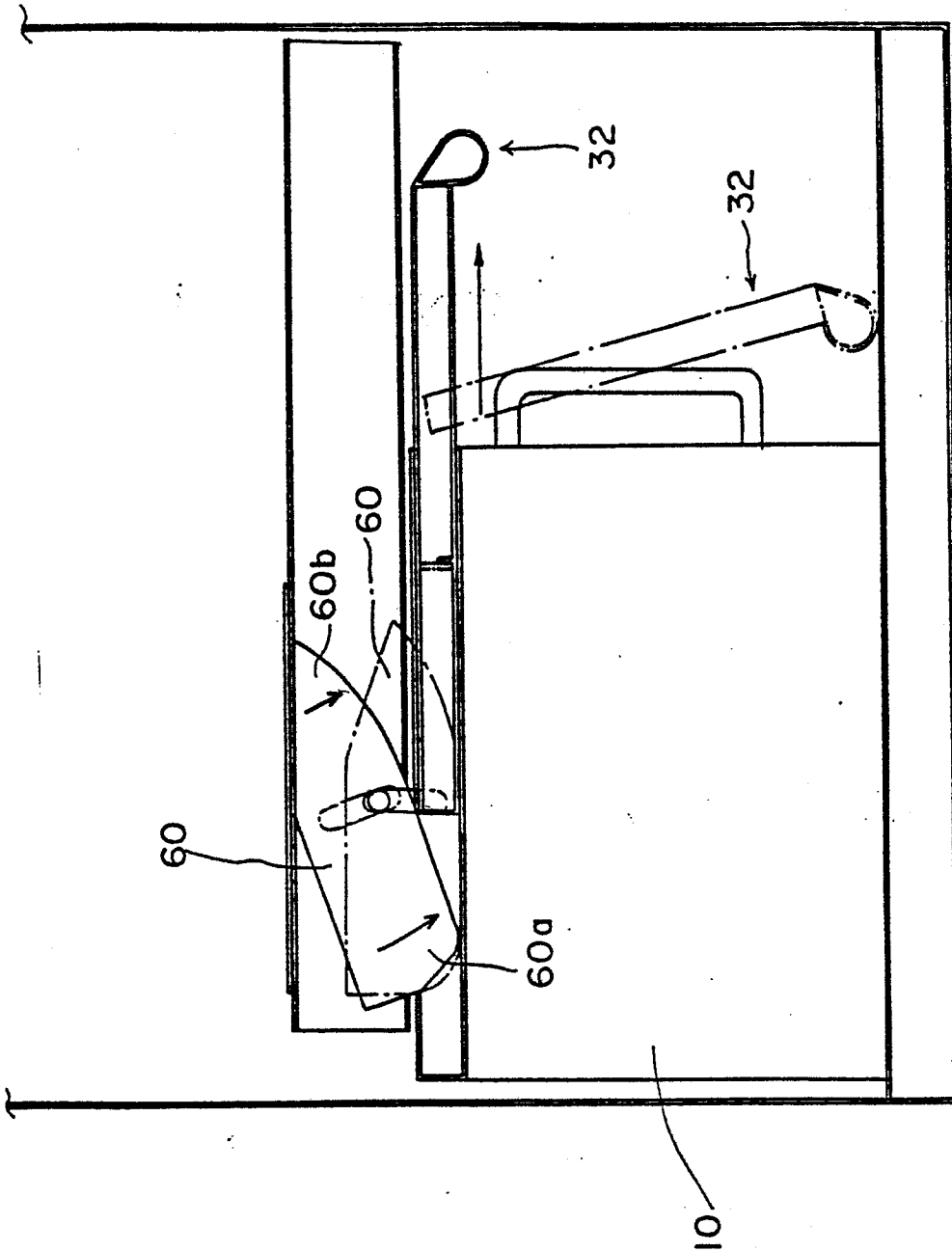

FIG. 27



0269731

## INTERNATIONAL SEARCH REPORT

International Application No. PCT/JP86/00233

I. CLASSIFICATION OF SUBJECT MATTER (If several classification symbols apply, indicate all) <sup>3</sup>		
According to International Patent Classification (IPC) or to both National Classification and IPC		
Int.Cl. <sup>4</sup> G07D9/00, G07F9/06		
II. FIELDS SEARCHED		
Minimum Documentation Searched <sup>4</sup>		
Classification System	Classification Symbols	
IPC	G07D9/00, G07F9/06, G07F7/04, B65H7/06, B65H43/04, B65H5/02, 5/06, E05G1/04, E05B63/00	
Documentation Searched other than Minimum Documentation to the Extent that such Documents are Included in the Fields Searched <sup>4</sup>		
Jitsuyo Shinan Koho	1952 - 1985	
Kokai Jitsuyo Shinan Koho	1971 - 1985	
III. DOCUMENTS CONSIDERED TO BE RELEVANT <sup>14</sup>		
Category <sup>15</sup>	Citation of Document, <sup>16</sup> with indication, where appropriate, of the relevant passages <sup>17</sup>	Relevant to Claim No. <sup>18</sup>
Y	JP, U, 55-67480 (Fuji Electric Co., Ltd.) 9 May 1980 (09. 05. 80) P.1, Fig.3 (Family: none)	1, 2
Y	JP, U, 54-36493 (Fuji Heavy Industries, Ltd.) 9 March 1979 (09. 03. 79) P.1, Fig.5 (Family: none)	1, 2
Y	JP, A, 55-69889 (Hitachi, Ltd.) 26 May 1980 (26. 05. 80) Column 7, line 18 to column 8, line 17, Fig. 10 (Family: none)	1, 2
Y	JP, U, 57-162254 (Sanyo Vending Machine Co., Ltd.) 13 October 1982 (13. 10. 82) P.1, Figs. 2, 3 (Family: none)	1, 2
A	JP, U, 48-2992 (Omron Tateisi Electronics Co.) 13 January 1973 (13. 01. 73) P.1, Figs. 1, 4 (Family: none)	2
<p><sup>14</sup> Special categories of cited documents:</p> <p>"A" document defining the general state of the art which is not considered to be of particular relevance</p> <p>"E" earlier document but published on or after the international filing date</p> <p>"L" document which may throw doubts on priority claim(s) or which is cited to establish the publication date of another citation or other special reason (as specified)</p> <p>"O" document referring to an oral disclosure, use, exhibition or other means</p> <p>"P" document published prior to the international filing date but later than the priority date claimed</p> <p>"T" later document published after the international filing date or priority date and not in conflict with the application but cited to understand the principle or theory underlying the invention</p> <p>"X" document of particular relevance; the claimed invention cannot be considered novel or cannot be considered to involve an inventive step</p> <p>"Y" document of particular relevance; the claimed invention cannot be considered to involve an inventive step when the document is combined with one or more other such documents, such combination being obvious to a person skilled in the art</p> <p>"&amp;" document member of the same patent family</p>		
IV. CERTIFICATION		
Date of the Actual Completion of the International Search <sup>2</sup>		Date of Mailing of this International Search Report <sup>2</sup>
July 29, 1986 (29. 07. 86)		August 11, 1986 (11. 08. 86)
International Searching Authority <sup>1</sup>		Signature of Authorized Officer <sup>20</sup>
Japanese Patent Office		

## FURTHER INFORMATION CONTINUED FROM THE SECOND SHEET

A	JP, U, 53-72986 (Toshiba Corporation) 19 June 1978 (19. 06. 78) P.1, Figs. 1 to 4 (Family: none)	2
A	JP, U, 53-154697 (Omron Tateisi Electronics Co.) 5 December 1978 (05. 12. 78) P.1, Figs. 1 to 4 (Family: none)	2
A	JP, B2, 56-36474 (Omron Tateisi Electronics Co.) 24 August 1981 (24. 08. 81) Column 7, line 40 to column 8, line 25, Fig. 5 (Family: none)	2

V.  OBSERVATIONS WHERE CERTAIN CLAIMS WERE FOUND UNSEARCHABLE<sup>10</sup>

This international search report has not been established in respect of certain claims under Article 17(2) (a) for the following reasons:

1.  Claim numbers..... because they relate to subject matter<sup>12</sup> not required to be searched by this Authority, namely:

2.  Claim numbers..... because they relate to parts of the international application that do not comply with the prescribed requirements to such an extent that no meaningful international search can be carried out<sup>13</sup>, specifically:

VI.  OBSERVATIONS WHERE UNITY OF INVENTION IS LACKING<sup>11</sup>

This International Searching Authority found multiple inventions in this international application as follows:

1.  As all required additional search fees were timely paid by the applicant, this international search report covers all searchable claims of the international application.

2.  As only some of the required additional search fees were timely paid by the applicant, this international search report covers only those claims of the international application for which fees were paid, specifically claims:

3.  No required additional search fees were timely paid by the applicant. Consequently, this international search report is restricted to the invention first mentioned in the claims; it is covered by claim numbers:

4.  As all searchable claims could be searched without effort justifying an additional fee, the International Searching Authority did not invite payment of any additional fee.

## Remark on Protest

- The additional search fees were accompanied by applicant's protest.  
 No protest accompanied the payment of additional search fees.