

12 **EUROPEAN PATENT APPLICATION**

21 Application number: **87202372.6**

51 Int. Cl.4: **F21V 11/02**

22 Date of filing: **01.12.87**

30 Priority: **08.12.86 BE 217498**

43 Date of publication of application:
15.06.88 Bulletin 88/24

64 Designated Contracting States:
BE DE FR LU NL

71 Applicant: **"ETAP"**
Antwerpsesteenweg 130
B-2150 Malle(BE)

72 Inventor: **Taeymans, Fransiscus**
Vlimmerseweg 26
B-2151 Beerse(BE)
Inventor: **Adams, Frans**
Liersesteenweg 262
B-2590 Berlaar(BE)

74 Representative: **Pieraerts, Jacques et al**
Bureau Gevers S.A. Rue de Livourne 7, B.1
B-1050 Bruxelles(BE)

54 **Luminaire with mirror reflectors capable of protecting against troublesome light spots.**

57 A luminaire consisting of a housing containing at least one lamp fitted inside a concave reflector, which is incorporated in the housing and which longitudinally extends above a row of small, transverse mirrors, each of the latter being fitted on its upper side with a light-reflecting cover, and its outer edges anchored in specially-provided recesses in the main reflector, characterized in that the shape of the light-reflecting covers is so designed that an observer, who looks obliquely or askance in the direction of the luminaire, fails to notice, outside of the therein fitted lamp (2) and its mirror image reflected on said reflector (3), the discomforting light spots caused by reflection from the transverse mirrors bouncing off the reflector (3), when this is viewed at an angle which in relation to the ceiling is less than 30-45°.

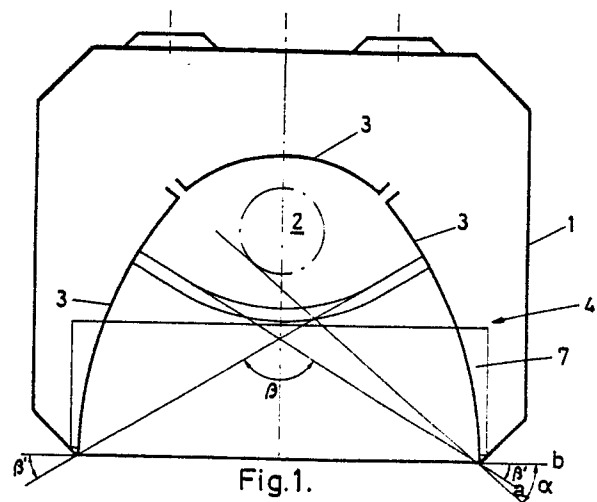

EP 0 271 150 A1

- 1 -

This invention concerns a luminaire with mirror reflectors, which can either be recessed in the ceiling, fitted flush to it or hung beneath it. It consists of a housing containing at least one lamp fitted inside a concave reflector, which is built into the housing and which longitudinally extends above a row of small, transverse mirrors. Each of these is fitted on its upper side with a light-reflecting cover and their outermost parts fit into specially-provided recesses in the main reflector.

Similar luminaires are common when they are equipped with transverse mirrors having an almost v - shaped cross-section and a flat strip of reflective material attached to their upper sides, and aim at providing low-level luminance in the usual angle of observation.

By "usual angle of observation" we mean here the angle in which one predominantly looks in the normal practice of using his sight. For example, in carrying out a desk task consisting of reading and writing on a horizontal surface, we can consider as usual an angle of observation ranging from $+ 10^\circ$ to the perpendicular of the desk top to angles lying on a horizontal plane (visual communications). For such task lighting it is common or desirable to construct the optical system in such a way as to prevent radiating large quantities of light allowing bright light spots to be visible within a beam shielding angle of $30-45^\circ$ to the horizontal angle of observation. Similar inconvenient light spots often occur when use is made of reflectors incorporating transverse mirrors, which are already on the market. These disturbances are the result of reflection from the flat, reflective strip of material one finds on these transverse mirrors.

The most common methods used today to prevent

these spots are the following:

- the covers placed above the v-shaped mirrors are either made out of a substance which reflects very little light, such as black synthetic material or are painted black, thus leading to a more than
5 20 % reduction in light-output ratio;

- no covers are used at all, thus creating less bright spots, due to the fact that only the raised edges of the v-shaped mirrors reflect the light - this still causes a more than 10 % reduction in light-output ratio;

10 - the lateral sides of the v-shaped mirrors are pulled through to such a high point (nearly or completely equalling the shielding angle α) in such a way that the spots which occur are in principle not visible from the angle in which the lamp itself is visible, thus causing the spots to disappear, as it were, behind the lamp.

15 In some designs the uppermost side of the row of mirrors is left open as well, in order to avoid that any potential reflection that falls on it via the multiple reflections in the concave, longitudinal reflector which are being reflected onto unexpected and undesired surfaces could become once again visible as bright spots.
20 In this case a reduction in light-output ratio of more than 20% can be reached. Such a solution to the problem was put forward in French patent no. 2.554.549. The shortcomings in the solution we have been dealing with here were thus described at that time and place.

25 The invention here described aims, through the use of an optical system based on the original transverse mirrors, at directing the light in such a way that:

1) the task to be lit is illuminated in the most efficient way possible, thus creating optimum illuminance levels of light intensity and optimum
30 luminance and/or colour contrast. The task lighting can regard for example reading, writing, drawing or VDU work, or it can involve assembling/checking various elements in industrial spaces;

2) large quantities of incident light rays emanating from the luminaire are prevented from being beamed directly into the eyes of
35 the observer from angles which hardly differ from the usual angle

of observation, thus reducing the viewer's capacity to perceive small contrasts and/or details and, in so doing, creating an disability glare; 3) surfaces, (even relatively small ones) which are highly luminant in relation to their normal backgrounds are prevented from being visible from angles which hardly differ from the usual angle of observation (psychological or discomfort glare). Besides the disturbance provoked by looking directly at the spots in the luminaire, reflections from these highly-luminous spots onto a VDU can hinder the VDU operator's task.

In order to direct the light in the way just described, the invention defines the shape of the above-mentioned, light-reflecting covers in such a way that an observer, while looking obliquely or askance towards the luminaire will fail to see the troublesome light spots which are occurring due to reflection on the reflector from the above-mentioned transverse mirrors, outside of the lamp fitted to the luminaire and its mirrored image on the reflector. This will not happen if the angle of observation, in relation to the ceiling, is less than 30-45°, that is, the desired angle of observation, in which an observer just fails to perceive the lamp or its mirrored image. This is done in such a way that the observer who fails to perceive the lamp is also unable to see any light spots at all.

In a preferably applied embodiment, the above-mentioned transverse mirrors, when seen in longitudinal section, consist of a right-angled part on the bottom, above which is fitted a covering strip of material, which v-shaped strip may be described as having the lines of the v-shape forming an angle that is approximately 90-120°, the two lines of which being joined by a curved piece which is tangentially attached to them both.

Other details and advantages of the invention will become clear from the following description of a luminaire, built in accordance with said invention. This description is to be seen solely as an example, and does not limit the invention.

Figure 1 is a cross-section of the luminaire, according to the invention.

Figure 2 is a longitudinal cross-section of a part of the same luminaire.

Figure 3 is, on a different scale, a side view of a transverse mirror.

5 Figure 4 is, on a different scale, a side-view of the commonly used type of transverse mirror.

Figure 5, also on a different scale, is a cross-section of a transverse mirror, as a variant.

10 The luminaire, in accordance with the invention specifications and as shown in the above-mentioned figures, consists essentially of a housing indicated as (1) in Figure 1.

The elements and parts necessary for fitting at least one lamp (2) do not pertain to the essence of the invention itself, and will therefore not be described herein any further.

15 Built into the housing (1), this reflector (3) is mounted partially along each side and partially above the lamp (2). Seen in section, it is mainly concave. This reflector can consist of either a single piece or, as seen in Figure 1, three different parts.

20 Along the whole length of the reflector (3) small transverse mirrors are mounted. The outer edges of these mirrors are fastened to the reflector (3) in specially-provided recesses. When seen in cross-section, both the transverse mirrors according to the invention, as well as those which have been in regular use until now, display, at least in part, a v-shaped section. In order to allow
25 the scope of the invention to better emerge, reference is first made to the design shown on Figure 4. The commonly-used transverse mirrors (5) are mostly v-shaped in section, and their straight upper parts are fitted with a cover (6) that is clipped either above or onto the v-shaped part of the transverse mirror. In order to avoid
30 beaming the amount of light by means of these covers in the "wrong" direction, and thus causing the above-mentioned discomforting light effects, these covers have until now either been painted with a highly light-absorbent material, such as matt black enamel, or made out of matt black synthetic material. The result is a reduction in the
35 total amount of light emanating from the luminaire.

According to the invention, the total amount of light beamed is kept at maximum levels, and an observer, who looks obliquely or askance towards the luminaire from an angle of less than 30-45° to the ceiling, no longer sees the discomforting light spots described above; in other words, if the observer is unable to see the lamp itself, he is equally unable to see any light spots.

Two different designs for this are possible, and for the sake of clarity, they are represented in section, on Figures 3 and 5.

The transverse mirrors (4) (Figures 1, 2 and 3) consist of two, right-angled parts (7), shown in longitudinal section, which both, when seen in cross-section, combine to form a v-shape. If the case may be, they can be made out of a single piece. The right-angled concave parts (7) of the transverse mirrors (4) are joined at the top with strips (8) consisting of two nearly-flat, parallel parts. Seen in front view or in longitudinal section, these strips have a v-shaped appearance. The lines of this v-shape cross one another, forming an angle β of between \pm 90-120°. An essential element for the invention is the fact that the angle α (formed between the tangent (a) and the lamp (2), and the tangent (b) with the reflector underside) coincides with the angle β' (formed by the tangent (c) with the upperside of a transverse mirror (4), and the tangent (b) with the reflector underside). The strips (8) run between the two lines of the v-shape along a curve which forms a tangential circular connection with the above-mentioned v-shaped strips.

The strips (8) rise upwards at their outermost parts, and above them is a cover (9) made out of light-reflecting material. The shape of the cover (9) (the angles β' and the rounded part beneath the lamp(s)) has been chosen in such a way that, combined with the uppermost longitudinal mirror and the lateral longitudinal mirrors (3)), if one glances sideways from any angle which in relation to the horizontal plane is less than the angle α , hardly any highly-luminant spots or none at all would be noticeable. The light striking the cover (9) is then reflected at an angle greater than the angle α .

The amount of light recuperated from the cover (9) in certain cases results in a more than 20% increase in the total light-output as compared to certain other designs which make no use of this specially-designed, light-reflecting cover (9). The special
5 curve of this cover (9), combined with the curving of the longitudinal mirrors (3), means that it is not necessary that the sides (8) of the transverse mirrors and the attached light-reflecting cover (9) are placed so high that angle β' coincides, as it were, with angle α .

The most common designs are those where angle
10 β' is approximately 28° and where angle α is approximately 40° , thus giving rise to the fact that the vertical strips (8) here fail to act as a "cover" for the light spots, which would then be visible on the longitudinal reflector (3) from an angle less than angle α .

The flat strips (8) and the concavely-bent parts
15 (7) can either be constructed out of a single piece or consist of two separate parts.

As can be seen from Figure 1, it can be deduced that the shape of the light-reflecting covers (9), as in the design described above, has been worked out in such a way as to bring
20 about the complete or practically-complete disappearance of the discomfoting light spots which occur in most other designs and are visible from angles which are less than the strived after shielding angle 2 in relation to the usual angle of observation. An added important advantage is that this comes about without having to make
25 use of strongly light-absorbent materials to cover the upperside of the transverse mirrors. This means that the quantity of light falling on the covers (9) of the v-shaped transverse mirrors (4) is either not absorbed by them or is not beamed in "discomfoting directions", but instead is beamed by the proposed mirrored, light-recu-
30 peration system in such a direction that this quantity of light can be profitably made use of for increasing illuminance levels and luminance and colour contrasts during everyday sight tasks.

This is also the case of the design shown in section, on Figure 5. The transverse mirrors (10) on Figure 5 consist of an
35 upper and a lower part. The lower part (11), as seen in cross-section, shows the same rounded profile as in the transverse mirrors (4),

and the outer edges of the latter can optionally be similarly anchored in the same way in the recesses of the reflectors (3). The upper part (12) of a transverse mirror (10) is made in a reverse v-shape, the base of which fits into the base of the v-shaped lower part (11).
5 The uppermost angle of the reverse v-shaped upper part (12) is not greater than 50°. These structures, namely the transverse mirrors (10), can consist of two components but could, if necessary, be made out of a single piece of material.

10 The transverse mirrors (10), which in cross-section approach more or less the shape of a parallelogram, also offer advantages similar to those described above in as regards the transverse mirrors (4).

15 The invention naturally is not limited to the above-mentioned designs, and several changes could be made to them without going outside the framework of the patent application.

CLAIMS

1. A luminaire incorporating mirror reflectors, which can either be recessed in, fitted flush to, or hung beneath a ceiling, (usually a suspended one), consisting of a housing containing at least one lamp fitted inside a concave reflector, which is incorporated in the housing and which longitudinally extends above a row of small, transverse mirrors, each of the latter being fitted on its upper side with a light-reflecting cover, and its outer edges anchored in specially-provided recesses in the main reflector, characterized in that the shape of the above-mentioned, light-reflecting covers is so designed that an observer, who looks obliquely or askance in the direction of the luminaire, fails to notice, outside of the therein fitted lamp (2) and its mirror image reflected on said reflector (3), the discomforting light spots caused by reflection from the above-mentioned transverse mirrors bouncing off the reflector (3), when this is viewed at an angle which in relation to the ceiling is less than 30-45°, that is, the strived after angle from which a viewer just fails to perceive the lamp or its mirror image.

2. A luminaire according to claim 1, characterized in that the above-mentioned transverse mirrors (4), when seen in longitudinal section, consist of a right-angled lower part (7), above which is fitted a covering strip of material (8) which is v-shaped, the lines of the v-shape forming an angle of approximately 90-120°, and the two above-mentioned lines being joined by a curved piece tangentially attached to them both.

3. A luminaire according to claim 2, characterized in that the above-mentioned, uppermost, right-angled parts, when seen in cross-section, are of a reverse v-shape.

4. A luminaire according to one of claims 2-3, characterized in that distinguishing feature being that the above-mentioned strips (8), which when seen in longitudinal section are shaped like a right-angle, run either parallel, or nearly parallel one on top of another.

5. A luminaire according to one of claims 2-4, characterized in that a light-reflecting cover is fitted between the

above-mentioned strips (8).

5 6. A luminaire according to claim 1, characterized
in that the above-mentioned transverse mirrors (10), when seen longi-
tudinally, consist of two parts of a right-angled appearance, lying
one on top of another, to wit, an upper part (11) and a lower part -
(12), which, when seen in cross-section, take on the shape of two
triangles sharing a common base.

10 7. A luminaire according to claim 6, characterized
in that the above-mentioned triangle, which belong to upper part (12),
have a vertical angle that is not greater than 50° .

15

20

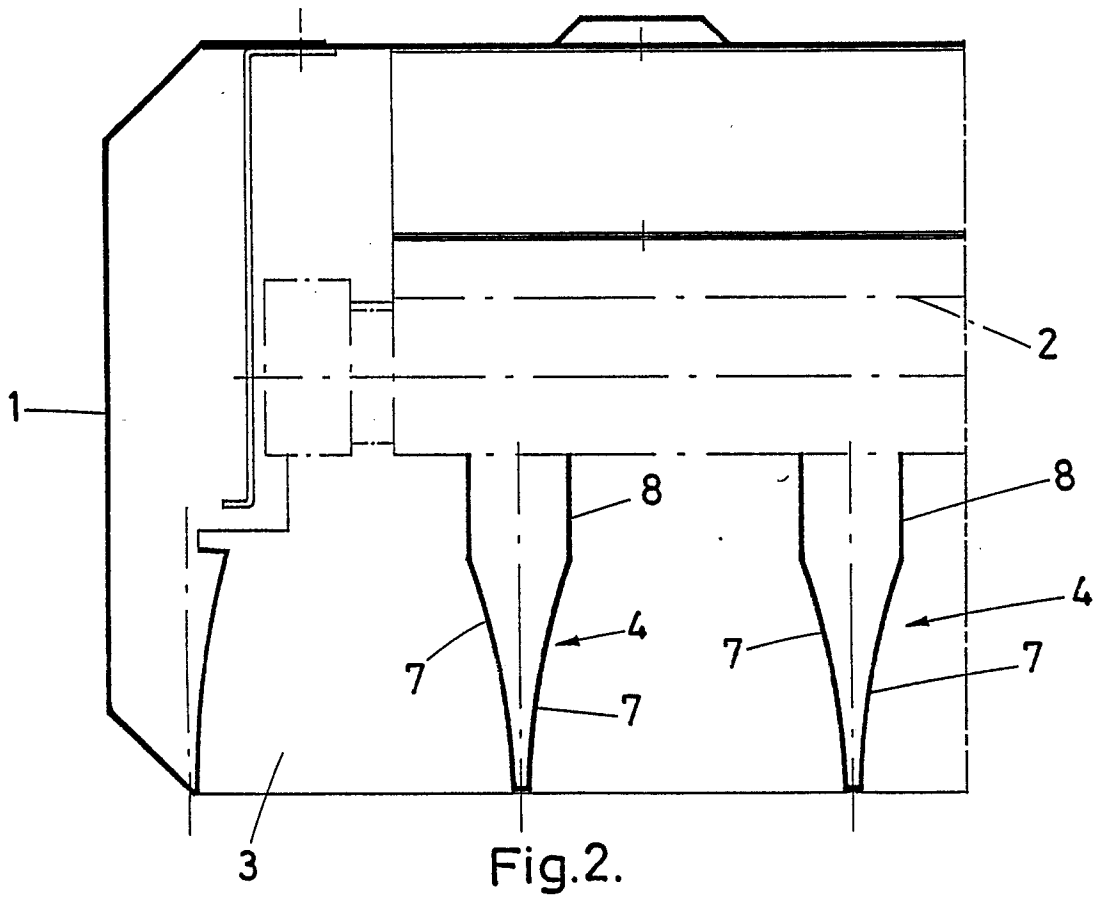
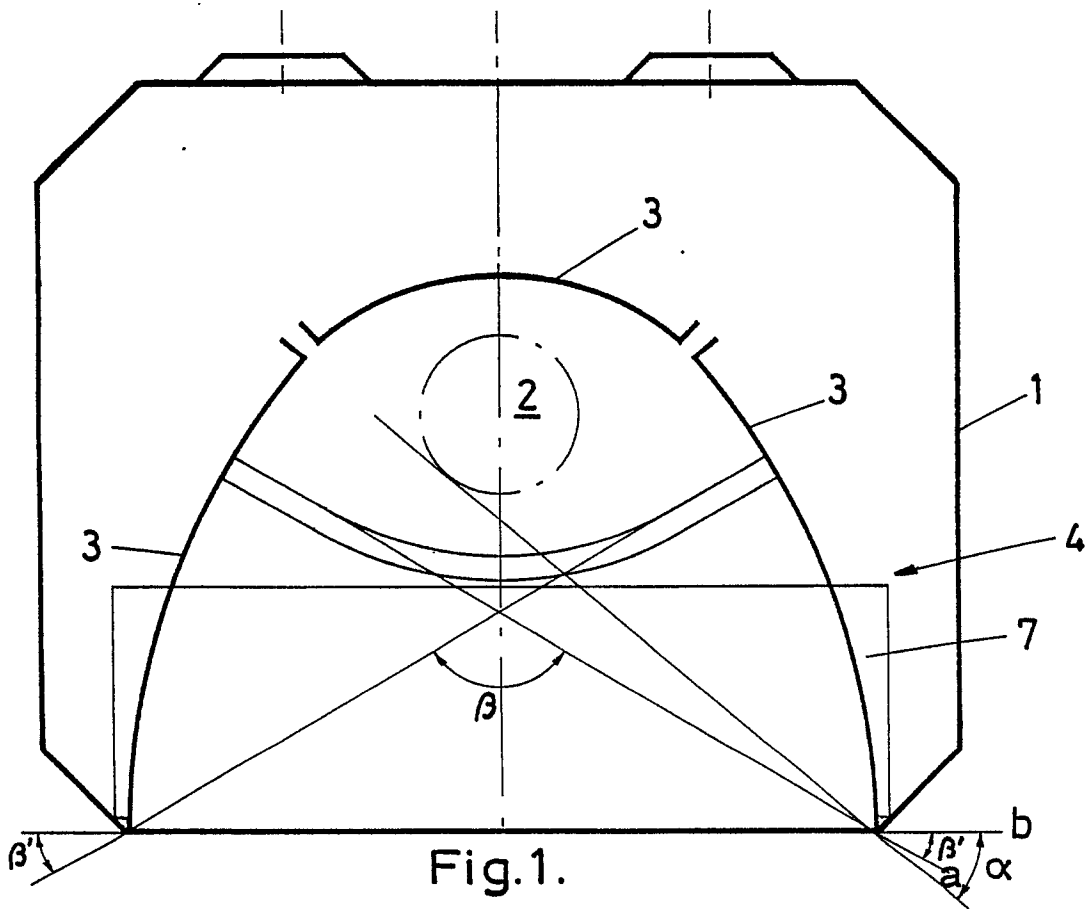

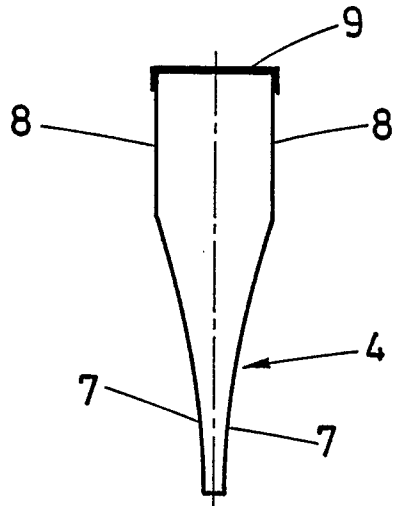

Fig.3.

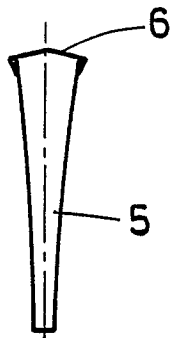

Fig.4.

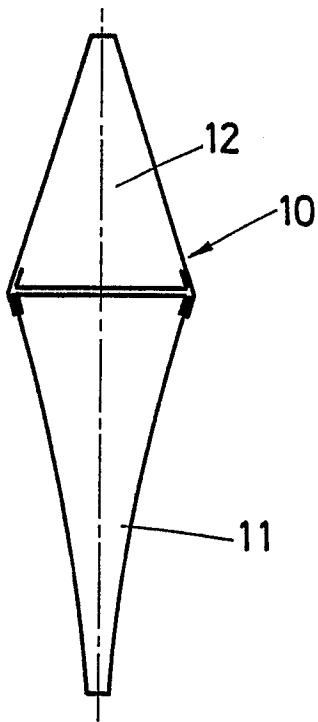

Fig.5.



DOCUMENTS CONSIDERED TO BE RELEVANT			
Category	Citation of document with indication, where appropriate, of relevant passages	Relevant to claim	CLASSIFICATION OF THE APPLICATION (Int. Cl. 4)
D,X	FR-A-2 554 549 (SABIR) * Figures 2-4 * ---	1-4	F 21 V 11/02
A	EP-A-0 122 972 (BARTENBACH) * Figures 1-3 * ---	1-5	
A	DE-A-3 215 026 (THORN EMI) * Figures 6-8 * -----	1-4,6,7	
			TECHNICAL FIELDS SEARCHED (Int. Cl.4)
			F 21 V
The present search report has been drawn up for all claims			
Place of search THE HAGUE		Date of completion of the search 22-02-1988	Examiner FOUCRAY R. B. F.
CATEGORY OF CITED DOCUMENTS		T : theory or principle underlying the invention E : earlier patent document, but published on, or after the filing date D : document cited in the application L : document cited for other reasons & : member of the same patent family, corresponding document	
X : particularly relevant if taken alone Y : particularly relevant if combined with another document of the same category A : technological background O : non-written disclosure P : intermediate document			