

⑫ **EUROPEAN PATENT APPLICATION**

⑰ Application number: **88200985.5**

⑴ Int. Cl.4: **B26F 3/00 , B26D 7/18 ,**
C03B 33/02

⑱ Date of filing: **17.05.88**

⑳ Priority: **18.05.87 NL 8701191**

㉑ Date of publication of application:
23.11.88 Bulletin 88/47

㉒ Designated Contracting States:
CH DE ES FR GB GR IT LI NL

㉓ Applicant: **R. de Groot Holding Laag-Zuthem**
B.V.
Pascalweg 3
NL-8013 RC Zwolle(NL)

㉔ Inventor: **Vanhoutte, Jan Eric Rene**
Moerkerksesteenweg 511
B-3810 Brugge 3(BE)
Inventor: **Izaks, Herman Berend**
Meidoornstraat 1
NL-7151 ZW Eibergen(NL)

㉕ Representative: **Schumann, Bernard Herman**
Johan et al
OCTROOIBUREAU ARNOLD & SIEDSMA
Sweelinckplein 1
NL-2517 GK The Hague(NL)

⑸ **A device and a method of separating a stack of flat elements.**

⑹ The present invention relates to a device for separating two elements which can be separated on a separating plane, for example stacks of cardboard planos, by applying of a force possessing a component extending at right angles to the separating plane.

This aim is achieved by arrangement of: a first clamping member (4) for clamping of the first element in a clamping direction extending parallel to the separating plane; and a second clamping member (5) for clamping the second element in the clamping direction, whereby the second clamping member (5) can be tilted on an axis of tilt extending at right angles to the clamping direction and parallel to the separating plane.

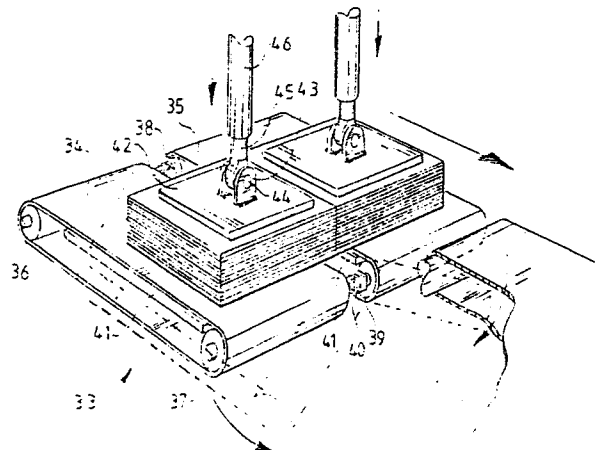

FIG. 2

EP 0 292 067 A1

A device and a method of separating a stack of flat elements

The present invention relates to a device for separating two elements which can be separated on a separating plane, for example stacks of cardboard planos, by applying of a force possessing a component extending at right angles to the separating plane.

Up until the present time such devices have been formed by work tables, whereby the separating operation has been performed by personnel. The separation of the stacks of cardboard planos is heavy work however, since in order to achieve a sufficiently large production capacity, thick stacks of cardboard sheets are separated into planos.

In order that the forces do not however become too great, during punching out of the cardboard sheets in which the planos are formed the joins for separating are given an insubstantial form. This results in the danger of the planos already coming loose from one another in the punching machine, which is of course undesirable. As a consequence of this the speed of the punching machine cannot be further increased either.

The object of the present invention is therefore to provide a device for separation of two elements that can be separated on a separating plane, whereby human muscle power is no longer necessary and whereby the joins between the separable elements can be given a sufficiently robust form that the danger of premature detachment is avoided.

This aim is achieved by arrangement of: a first clamping member for clamping of the first element in a clamping direction extending parallel to the separating plane; and a second clamping member for clamping the second element in the clamping direction, whereby the second clamping member can be tilted on an axis of tilt extending at right angles to the clamping direction and parallel to the separating plane.

It becomes possible using this device to separate stacks of planos with great force, without human intervention, so that the joins between the planos can be given a robust form. In addition movable stop members can be fitted to that the machine can be adapted to diverse sizes and shapes.

The current invention will be elucidated hereinafter with reference to annexed drawings, in which:

Figure 1 shows a schematic, perspective view of a first embodiment of the current invention; and

figure 2 shows a schematic, perspective view of a second embodiment of the current invention.

The device illustrated in figure 1 comprises a feed conveyor belt 1, a separating device 2 and a discharge conveyor belt 3. Separating device 2 is formed by a first clamping member 4 and a second clamping member 5.

The first clamping member 4 comprises a short conveyor belt 6 which is passed round two belt drums 7. Arranged beneath the upper half of conveyor belt 6 is a pressure plate (not shown in the drawing) for absorbing the clamping forces. Arranged above the conveyor belt is a positioning member 8 which is attached by means of a bracket 9 and a shaft 10 to a rod 11. Rod 11 can be moved in vertical direction by means of a hydraulic cylinder 12.

The second clamping member 5 is likewise formed by a conveyor belt 13 which is passed round a first belt drum 14 and a second belt drum 15. The shaft of belt drum 14 is fitted rigidly, so that belt drum 14 can only rotate, while the shaft of belt drum 15 can move just as conveyor belt 13 downward in a circular arc to a lower position shown with dashed lines. It is also possible to have the assembly formed by drums 14 and 15 rotate on another axis running parallel to that of drum 14.

Likewise arranged beneath the upper half of conveyor belt 13 is a pressure plate (not shown in the drawing) which can also take part in the downward directed tilting movement of belt 13 and the movable belt drum 15.

Also arranged above the belt 13 is a positioning member 8 which is attached by means of a bracket 9 and a shaft 10 to a rod 11 so that the positioning member can tilt relative to rod 11, while rod 11 can also be moved in vertical direction by means of a hydraulic cylinder 12. It is further possible to design the whole pressing device 8, 9, 10, 11, 12 such that it is tiltable on the same axis as the assembly of the two drums 14, 15.

Arranged above belt 13 are two movable stops 29 which can be moved upward by means of hydraulic cylinders 30.

Arranged adjoining conveyor belt 3 is a second separating device 16, the construction of which corresponds with the previously described separating device 2. The separating plane of this second separating device 16 extends however at right angles to the direction of the separating plane of the first separating device. By connecting these two separating devices 2, 16 in series it is possible to separate the elements for separating in two directions extending at right angles to each other.

In order to transport the elements for separation from conveyor belt 3 to the second separating device 16 a slider member 17 is fitted. This slider

member 17 is connected by means of a rod 18 to a hydraulic cylinder 19 so that the slider member can move in the direction extending at right angles to the direction of movement of conveyor belt 3. Instead of a conveyor belt a system of ropes or chains can also be employed.

Arranged following the second separating device 16 is a second discharge conveyor belt 20, above which is arranged another slider member 21 which is connected by means of a rod 22 to a hydraulic cylinder 23 so that slider 21 can move in the direction extending at right angles to the conveying direction of belt 20. Fitted adjoining this belt 20 is a discharge conveyor belt 24.

The operation of the combined separating device will be discussed in the following. Supplied on conveyor belt 1 are sheets of cardboard 25, each formed by four planos 26. The latter are separated from one another by two dividing lines 27, 28 at right angles to each other. The movement of the conveyor belt is controlled such that the stacks of cardboard 25 are fed to the separating device 2 one by one. The conveyor belts 6 and 13 are also driven during this process. The movement of the stack of cardboard sheets is continued until it comes up against movable stops 29.

The positioning members 9 are then moved downward by means of hydraulic cylinders 12 until they clamp the relevant planos against conveyor belts 6 and 13 and the pressure plates placed beneath them. The same result can be achieved by pressing up the planos by means of a pressing member between the belts 6, 13 against a fixed but nevertheless adjustable positioning member.

The stop members 29 are then moved away by means of hydraulic cylinders 30 and the second clamping member performs a tilting movement on the axis of tilt. During this tilting movement the conveyor belt 13, the pressure plate, the conveyor belt 13 and the drum 15 rotate downward on the shaft of drum 14 or on the axis of tilt arranged elsewhere. Because it can in any case rotate on the shaft 10 and because the pressure from above continues to be supplied, the positioning member 8 will take part in this turning movement, so that the planos clamped between the second positioning member 8 and conveyor belt 13 will also take part in this movement and the two stacks of planos are separated along the break line. When this tilting movement is completed it is again performed in reverse direction.

The conveyor belts 6 and 13 are thereby controlled such that the stacks of pair-wise attached planos arrive on conveyor belt 3 one lot at a time. These stacks 31 of pair-wise attached planos are there transported one lot at a time by slider member 19 to the second separating device 6 and subjected once more to a separating operation.

Resulting from the handling in this second separating device are separate stacks of planos 32 which move onto conveyor belt 20, there to be shifted one by one by slider 21 to the discharge conveyor belt 24. The cardboard sheets are thus separated into thick stacks in two directions without the intervention of human muscle power.

In the embodiment shown in figure 2 the separating device 33 consists of two conveyor belts 34, 35 divided in lengthwise direction. Conveyor belt 34 is passed round two belt drums 36, 37, while conveyor belt 35 is passed round two belt drums 38, 39. Belt drums 36 and 38 are joined to each other by means of a flexible coupling 40, just as belt drums 37 and 39. Further arranged under each of the belts 34, 35 is a pressure plate 41, 42. Disposed once more above the upper half of conveyor belt 34, 35 is a positioning member 42 which is connected by means of brackets 43, a shaft 44 and a rod 45 to a hydraulic cylinder 46.

The operation of this second embodiment of the current invention is identical to that of the embodiment shown in figure 1, with the exception that the conveyor belts can be tilted in lengthwise direction. This has the advantage that this device can be placed directly following the first separating device from figure 1 so that for separation in the second direction no change in the conveying direction is necessary. Both separating devices 2, 16 can also be placed following each other, whereby however a rotary table has to be interposed. Further shown in figure 2 is that both conveyor belts can be tilted downward. It is also conceivable that only one of the conveyor belts is downward tiltable.

Using this device it is also possible to separate the stacks of planos from each other without human intervention.

The above described embodiments relate to the separation of stacks of planos. The device according to the current invention can also be employed for the separating of other separable objects.

Use is made with the above described embodiments of hydraulic cylinders 12 for effecting movement of the positioning members. It is also possible to make use of pneumatic cylinders, electro-motors or hand wheels.

It is possible to employ other transporting means instead of the slider member used in the above embodiments.

It is in addition possible according to the present invention to separate elements which are each partially separable in multiple parallel planes, for instance when two elements are joined to each other by a dividing line in crenellated form and the joins to be separated are only present on the end faces.

Such elements may also be separated succes-

sively stepwise, that is, plane by plane.

When the device intended for two separating planes at right angles to each other is used only for one separating plane, a separating device can be switched off and used as a conveyor device.

Claims

1. Device for separating at least two elements which can be separated on at least one parallel separating plane by applying of a force possessing a component extending at right angles to said separating plane, **characterized by:**

- a first clamping member for clamping of the first element in a clamping direction extending parallel to said separating plane; and

- a second clamping member for clamping the second element in the clamping direction,

- whereby said second clamping member can be tilted on an axis of tilt extending at right angles to said clamping direction and parallel to said separating plane.

2. Device as claimed in claim 1, **characterized in that** both clamping members are arranged for clamping a stack of elements.

3. Device as claimed in claim 1 or 2, **characterized in that** the axis of tilt is placed at some distance from the clamping members.

4. Device as claimed in claim 1, 2 or 3, **characterized in that** each of the clamping members is formed by a bearing transporting member and a positioning member movable in vertical direction.

5. Device as claimed in claim 4, **characterized in that** the bearing transporting member is a conveyor belt.

6. Device as claimed in claim 5, **characterized in that** the direction of movement of the conveyor belt is parallel to the separating plane.

7. Device as claimed in claim 5, **characterized in that** the direction of movement of the conveyor belt extends at right angles to the separating plane.

8. Device as claimed in any of the foregoing claims, **characterized in that** a first controllable transporting member is connected in front of the first clamping member and that a second controllable transporting member is arranged behind the second clamping member.

9. Device for separating elements that are separable along two dividing lines extending substantially at right angles to each other, **characterized by** two devices as claimed in any of the foregoing claims extending substantially at right angles to each other.

10. Device as claimed in any of the foregoing claims, **characterized in that** the elements are planos.

11. Device as claimed in any of the foregoing claims, **characterized in that** the elements are separated successively along the individual separating planes.

12. A method of separating into two parts of a stack of flat elements provided with a weakening line, e.g. card board planos, said method comprising the steps of:

(1) providing the flat elements, each being provided with a weakening line,

(2) forming a stack of said flat elements in such a way that the weakening lines are all positioned in substantially one plane extending substantially perpendicularly relative to the main plane of each of said elements,

(3) clamping in the stack at both sides relative to said plane,

(4) exerting a tilting force around said plane, in such a way that the flat elements are separated one by one over their respective weakening lines, and

(5) releasing the clamping in.

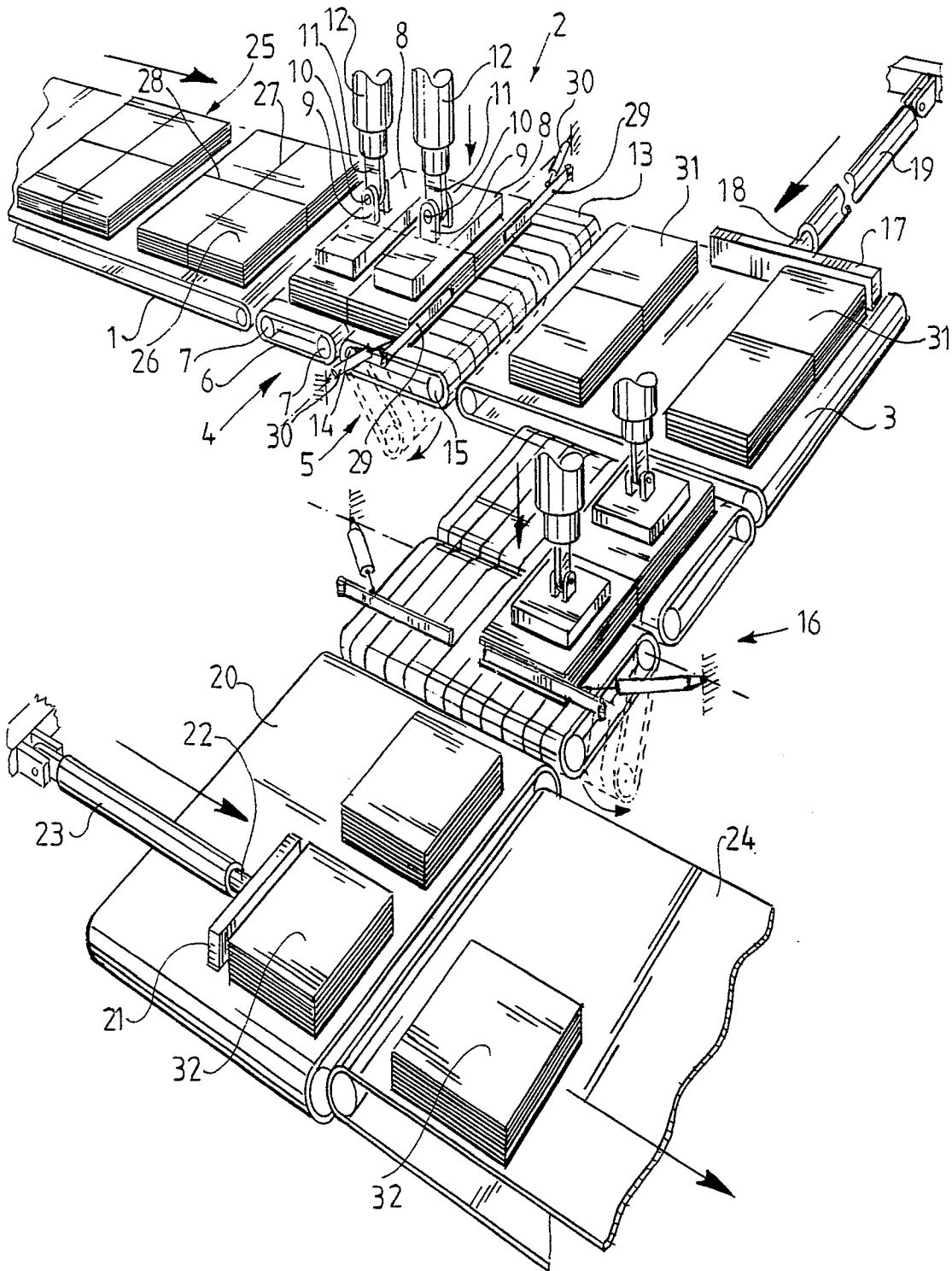

FIG.1

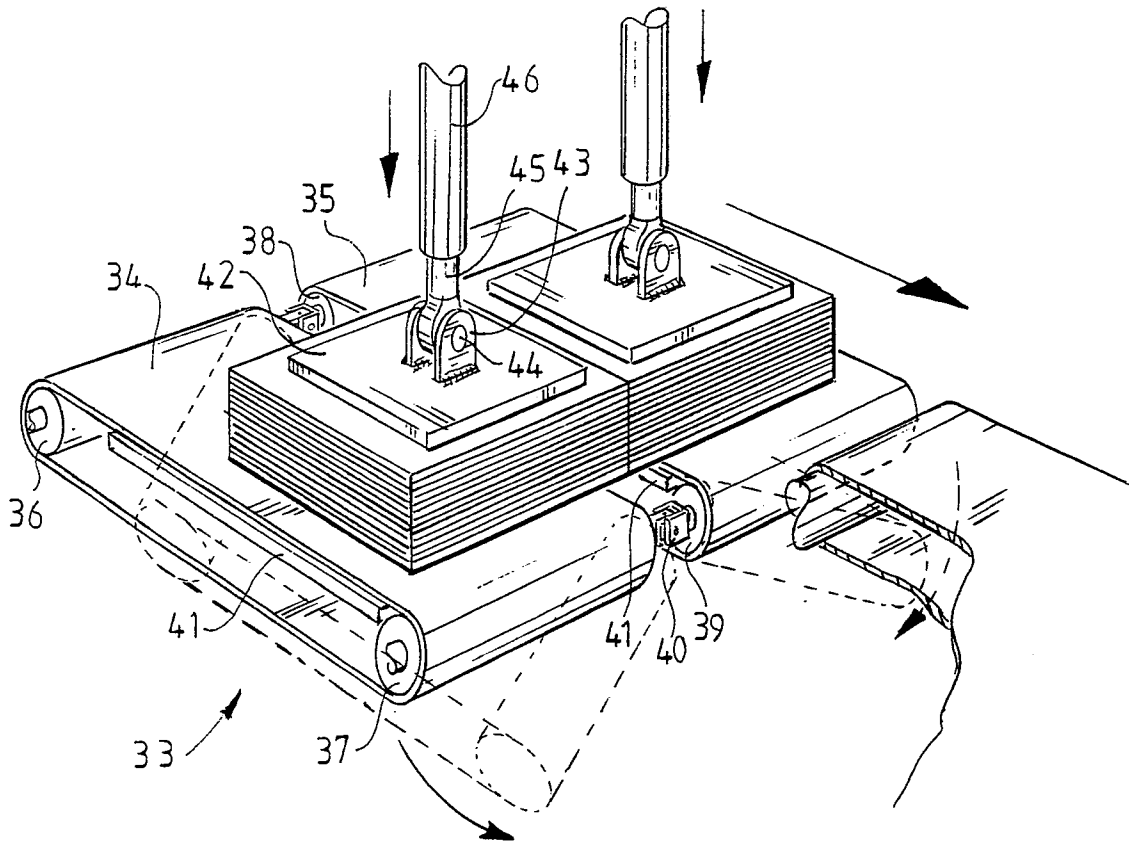

FIG. 2



DOCUMENTS CONSIDERED TO BE RELEVANT			
Category	Citation of document with indication, where appropriate, of relevant passages	Relevant to claim	CLASSIFICATION OF THE APPLICATION (Int. Cl.4)
X	DE-A-2 353 997 (STANZTECHNIK GmbH RÖDER & SPENGLER) * Figures 8,9; page 12, lines 20-24; page 13, paragraph 1 *	1-3	B 26 F 3/00 B 26 D 7/18 C 03 B 33/02
Y	---	4,5,7-11	
X	FR-A-2 211 872 (INTERNATIONELLA SIPOREX AB) * Figures 1-2; page 6, lines 13-18 *	1,3,12	
X	DE-C- 114 293 (C. DUGON) * Whole document *	1,3,12	
Y	FR-A-2 514 296 (R. LUCAS) * Figures 1,3,6; claim 1 *	4,5,7-11	
A	FR-A-2 275 308 (STANZTECHNIK GmbH RÖDER & SPENGLER) * Figures 5,6; claims 5,6 *	1	
A	JP-A-51 055 311 (NIPPON SHEET GLASS) * Figure 2 *	6	TECHNICAL FIELDS SEARCHED (Int. Cl.4)
A	FR-A-1 570 504 (ATELIERS HEUZE, MALEVEZ & SIMON REUNIS S.A.) * Figures 1,2; page 1, column 2, paragraphs 2,3 *	1,3	B 26 F B 26 D B 31 B B 28 B
A	FR-A-2 302 974 (PILKINGTON BROTHERS LTD) * Figures 7,8; page 9, lines 18-35 *	1	
The present search report has been drawn up for all claims			
Place of search THE HAGUE		Date of completion of the search 18-08-1988	Examiner WEBER P. L. P.
CATEGORY OF CITED DOCUMENTS X : particularly relevant if taken alone Y : particularly relevant if combined with another document of the same category A : technological background O : non-written disclosure P : intermediate document T : theory or principle underlying the invention E : earlier patent document, but published on, or after the filing date D : document cited in the application L : document cited for other reasons & : member of the same patent family, corresponding document			

EPO FORM 1503 03.82 (P0401)