

12

**EUROPEAN PATENT APPLICATION**

21 Application number: 88304566.8

51 Int. Cl.4: E 05 D 7/10

22 Date of filing: 20.05.88

30 Priority: 21.05.87 GB 8712003

43 Date of publication of application:  
23.11.88 Bulletin 88/47

84 Designated Contracting States: DE ES FR GB IT

71 Applicant: I.H.W. Engineering Limited  
Stratford Road  
Warwick CV34 6AL (GB)

72 Inventor: Aitken, Cliff  
3, Marten Close  
Hampton Magna Warwick (GB)

74 Representative: Dealtry, Brian et al  
Eric Potter & Clarkson 14, Oxford Street  
Nottingham NG1 5BP (GB)

54 Lift-off hinge assembly.

57 A hinge assembly (10) including a first hinge leaf (11) hingedly connected to a second hinge leaf (12) by a hinge pin (14), the hinge pin (14) being detachably secured in one of the hinge leaves to enable separation of the hinge leaves, the hinge pin (14) being axially slidably received in a bore (12b) formed in said one hinge leaf, a retaining member (30) being screw threadedly received in a threaded bore extending generally tangentially to and intersecting said bore (12b) so as to define a window in the periphery of said threaded bore (12b), said retaining member (30) when screwed along said threaded bore (12b) engaging the periphery of the pin (14) projecting through said window to secure the pin relative to said one hinge leaf.

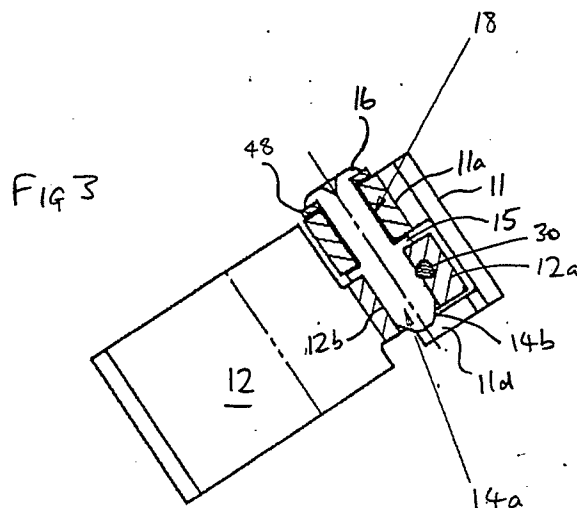

## Description

## LIFT-OFF HINGE ASSEMBLY

The present invention relates to a lift-off hinge assembly which is particularly suitable for the mounting of vehicle doors.

According to one aspect of the present invention there is provided a hinge assembly including a first hinge leaf hingedly connected to a second hinge leaf by a hinge pin, the hinge pin being detachably secured in one of the hinge leaves to enable separation of the hinge leaves, the hinge pin being axially slidably received in a bore formed in said one hinge leaf, a retaining member being screw threadedly received in a threaded bore extending generally tangentially to and intersecting said bore so as to define a window in the periphery of said threaded bore, said retaining member when screwed along said threaded bore engaging the periphery of the pin projecting through said window to secure the pin relative to said one hinge leaf.

Various aspects of the present invention are hereinafter described with reference to the accompanying drawings, in which:-

Figure 1 is a side view of a hinge assembly according to the present invention;

Figure 2 is a plan view from beneath of the hinge assembly shown in Figure 1; and

Figure 3 is a sectional view taken along lines X-X in Figure 2.

The hinge assembly is generally shown at 10 and includes a first hinge leaf 11 which is hingedly connected to a second hinge leaf 12 by a hinge pin 14. In use, hinge leaf 11 is attached to a vehicle door and hinge leaf 12 is attached to the vehicle body.

The hinge pin 14 is rotatably received in a boss portion 11a of the hinge leaf 11 and is restrained against axial withdrawal therefrom. In this respect, the pin 14 is provided with a peripheral flange 15 which acts to restrain relative axial movement in one direction between the pin 14 and boss portion 11a.

Relative axial movement between the pin 14 and boss 11a in the opposite direction is prevented by a peripheral flange 16 formed at one terminal end of the pin 14. The peripheral flange 16 is formed by deformation of said one terminal end of the pin 14 after it has been introduced through the boss portion 11a.

A bush liner 18 is preferably located between the pin 14 and boss 11a so as to provide a lubricated close tolerance fit therebetween. In this way pin 14 is able to rotate smoothly relative to boss 11a without play. The liner 18 is preferably a plastics material reinforced with a metal mesh; Metaloplast (Registered Trade Mark) is a suitable material.

The lower portion 14a of the hinge pin 14 is received in a boss 12a of leaf 12. The pin 14 has a lower terminal portion 14b which is of chamfered configuration to facilitate entry of the pin portion 14a into the bore 12b formed in boss 12a. In use, when the hinge leaf 12 is attached to the vehicle body the boss 12a is located beneath boss 11a so that the weight carried by hinge leaf 11 urges pin 14 axially toward boss 12 ensuring that the flange 15 rests on

the upper surface of the boss 12a.

The pin 14 is detachably held within the boss 12a by means of a screw threaded retaining member 30. The retaining member 30 acts to prevent axial withdrawal of the pin 14 from the boss 12a and also acts to prevent relative rotation between the boss 12a and pin 14.

The retaining member 30 is received in a screw threaded bore 31 which extends generally tangentially relative to the bore 12b such that bores 12b and 31 intersect to provide a window or aperture located on the circumferential periphery of bore 31. Thus when the pin 14 is located within bore 12b it penetrates radially a predetermined amount into bore 31.

Accordingly when the retaining member 30 is screwed along bore 31 it will reach the window and interfere with the pin 14. The relative hardnesses of the materials used for the pin 14 and retaining member 30 are chosen such that deformation of the pin 14 and/or the retaining member 30 are/is caused as the retaining member 30 passes the window.

In order to facilitate passage of the retaining member 30 passed the window the cross-sectional shape of the retaining member 30 is provided with flats. In this way the torque required for rotating the retaining member 30 is reduced whilst maintaining a desired amount of interference between the pin 14 and retaining member 30. In the illustrated embodiment the retaining member 30 is shown as being tri-lobal; it will be appreciated however that four or more flats may be provided. It is to be noted that herein a "flat" also covers curved surfaces having a relatively large radius of curvature.

Initially the hinge 10 is preferably assembled such that the retaining member 30 is screwed along the bore 31 by a sufficient amount to only just grip the pin 14. In this way the retaining member 30 may be easily retracted along bore 31 to enable release of pin 14 and thereby enable the hinge 10 to be separated after mounting on the vehicle door and body.

Preferably the hinge 10 is provided with a temporary stop for limiting the maximum open position of the vehicle door. In this respect a thin plate 48 is interposed between flange 16 and boss 11a. The plate 48 is gripped by the flange 16 and thereby is rotationally locked with respect to the pin 14. The plate 48 is provided with a stop portion 48a which is arranged to abut against a projection 11c on the hinge leaf boss 11a and thereby provide a limit stop for limiting the amount of relative angular displacement between hinge leaves 11, 12.

The hinge leaf 11 is provided with an interleaving projection 11d which is engageable with boss 12a to prevent axial separation of the hinge leaves 11, 12. The boss 12a is shaped so as to not engage with projection 11d when the leaves 11, 12 are opened to the position defined by stop 48a. Accordingly separation of a door from a vehicle body is easily achieved by opening the door to the position defined

by the stop 48 and then unscrewing retaining member 30 for each hinge 10 and then raising the door to axially separate the hinges.

Use of the temporary stop is advantageous since it enables the vehicle to be painted without incorporating a separate conventional door check mechanism. After painting the doors are separated from the vehicle body for fitment. On remounting of the doors to the vehicle body, the temporary stop is no longer required and so the operative renders the temporary stop inoperable by bending the plate 48 to move the stop 48a out of the path of travel of projection 11c. The plate 48 may also be used at this time to rotate pin 14 within bore 12b so as to present a fresh undeformed surface portion of the pin in the window of bore 31.

The retaining member 30 is now screwed fully home along bore 31 which results in its head 30a engaging the boss 12a. In this position, the terminal end of the retaining member 30 has passed beyond the pin 14 thereby providing a secure connection between the pin 14 and retaining member 30. In this respect it will be appreciated that the connection between the retaining member 30 and pin 14 is maintained until the terminal end of the retaining member is retracted passed the pin 14. Thus the retaining member has to move axially a substantial distance before the connection with the pin 14 is broken.

It is envisaged that the head 30a may be arranged to interfere with hinge leaf 11 to prevent full closing of the door when the retaining member 30 has retracted by a predetermined distance prior to disconnection between the pin 14 and retaining member 30. In this way a warning is provided that the retaining member 30 is retracting from the pin 14 before the connection is actually broken.

**Claims**

1. A hinge assembly including a first hinge leaf hingedly connected to a second hinge leaf by a hinge pin, the hinge pin being detachably secured in one of the hinge leaves to enable separation of the hinge leaves, the hinge pin being axially slidably received in a bore formed in said one hinge leaf, a retaining member being screw threadedly received in a threaded bore extending generally tangentially to and intersecting said bore so as to define a window in the periphery of said threaded bore, said retaining member when screwed along said threaded bore engaging the periphery of the pin projecting through said window to secure the pin relative to said one hinge leaf.

2. A hinge assembly according to Claim 1 wherein the hinge pin and/or retaining member are deformed by passage of the retaining member through said window.

3. A hinge assembly according to Claim 1 or 2 wherein the retaining member is provided with flats to facilitate passage of the retaining

member passed the window.

4. A hinge assembly according to Claim 1, 2 or 3 wherein the retaining member has a head which engages said one hinge leaf when the retaining member is fully inserted into said threaded bore, the head interfering with said other hinge leaf when the retaining member has retracted from said threaded bore by a predetermined distance prior to disconnection between the hinge pin and the retaining member.

5. A hinge assembly according to Claim 1, 2, 3 or 4 wherein a temporary stop plate is provided secured to the hinge pin.

5  
10  
15  
20  
25  
30  
35  
40  
45  
50  
55  
60  
65

0292296

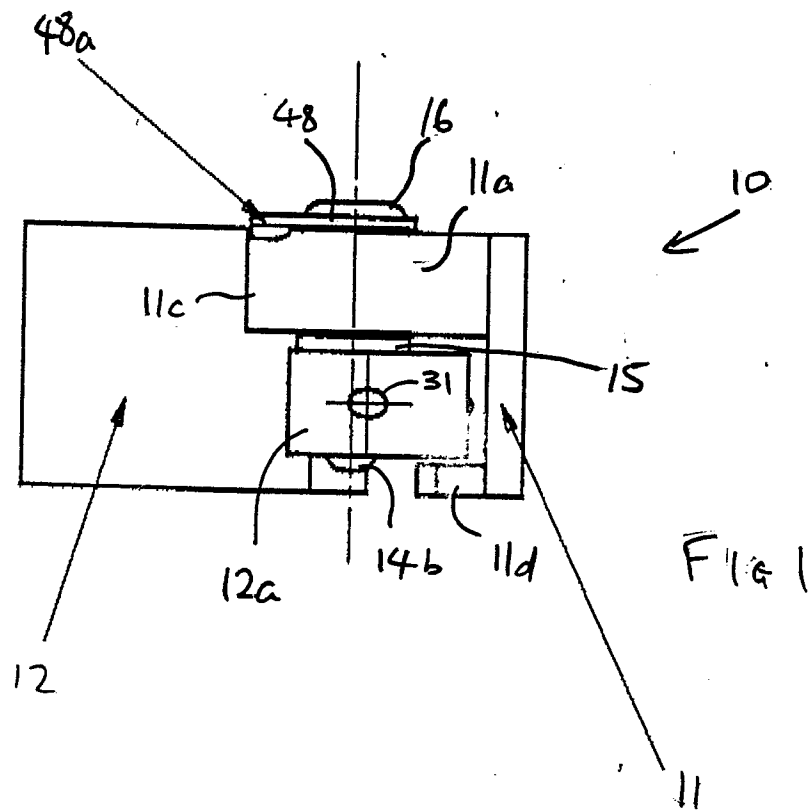

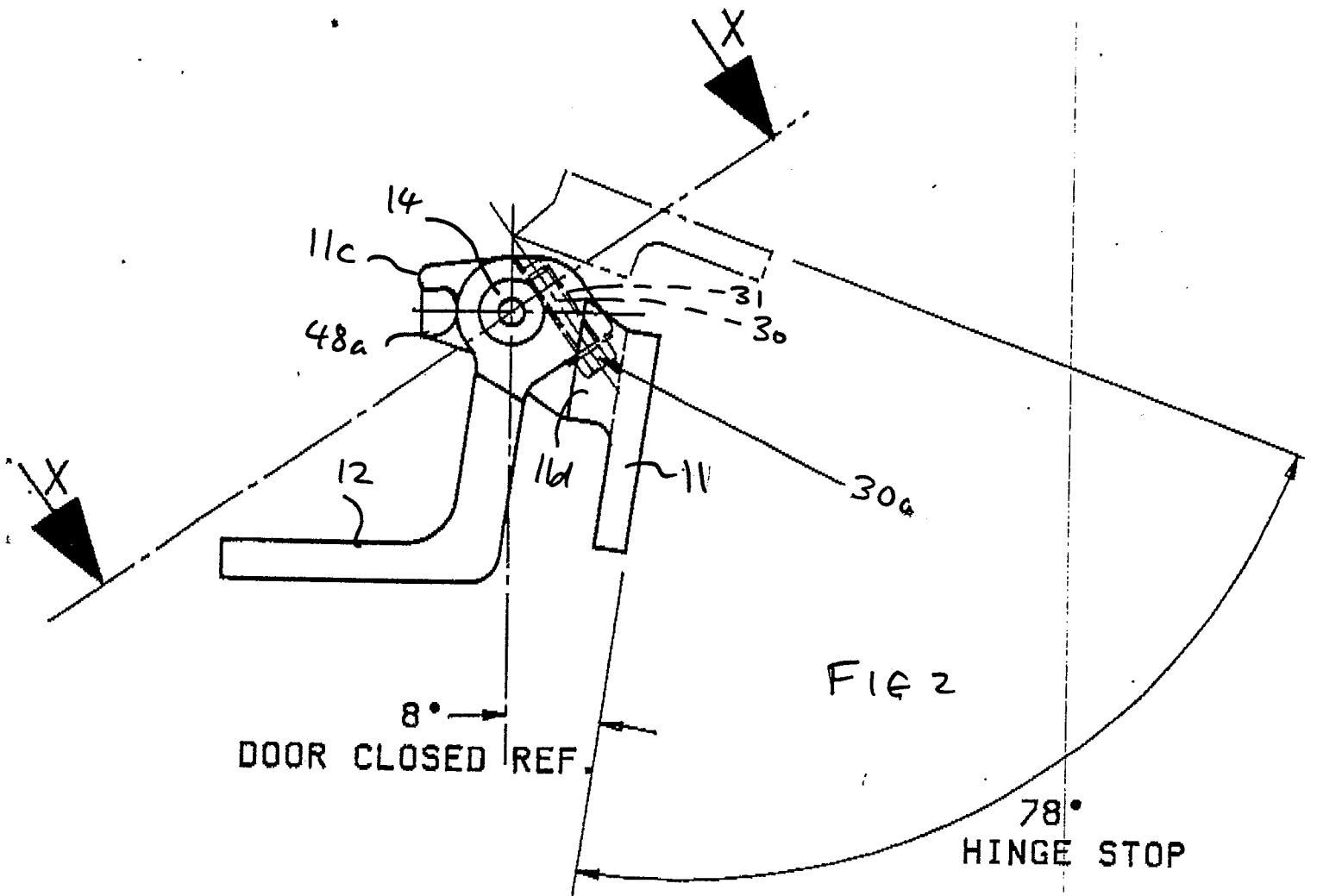
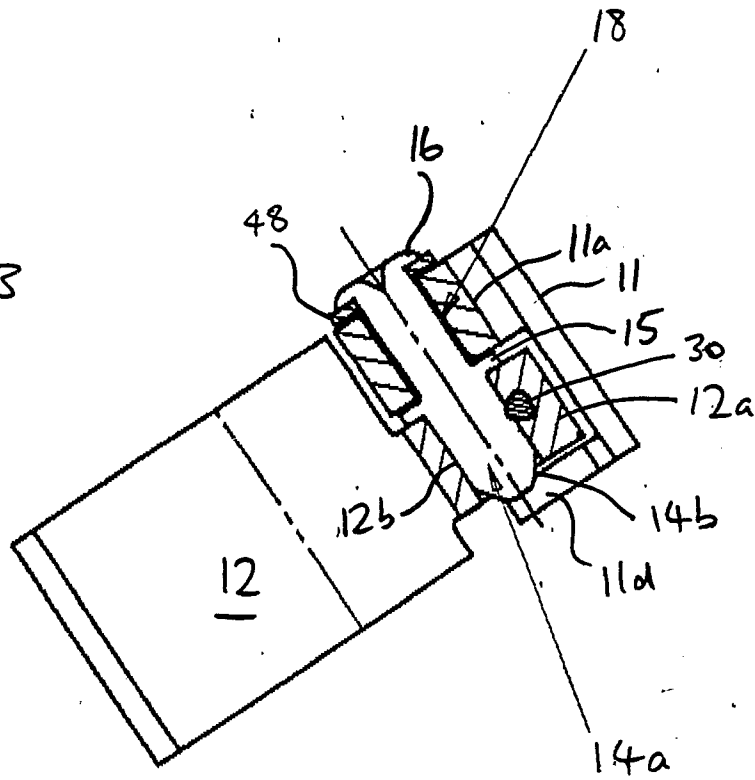

FIG 3





DOCUMENTS CONSIDERED TO BE RELEVANT			
Category	Citation of document with indication, where appropriate, of relevant passages	Relevant to claim	CLASSIFICATION OF THE APPLICATION (Int. Cl.4)
X,P	EP-A-0 228 187 (THE BLOXWICH LOCK AND STAMPING CO., LTD) * Figure 13; column 4, lines 16-55 *	1	E 05 D 7/10
Y,P	---	2,3	
Y	US-A-1 787 017 (F.P. ABRAM) * Figure 6; page 2, column 1, lines 9-27 *	2	
Y	EP-A-0 024 729 (SIEMENS AG) * Figure 2; page 3, lines 10-15 *	3	
A	EP-A-0 151 409 (LUNKE & SOHN GmbH) * Figure 2; page 3, line 14 - page 4, line 7 *	5	
The present search report has been drawn up for all claims			TECHNICAL FIELDS SEARCHED (Int. Cl.4)
			E 05 D
Place of search		Date of completion of the search	Examiner
THE HAGUE		29-07-1988	KISING A.J.
CATEGORY OF CITED DOCUMENTS			
X : particularly relevant if taken alone		T : theory or principle underlying the invention	
Y : particularly relevant if combined with another document of the same category		E : earlier patent document, but published on, or after the filing date	
A : technological background		D : document cited in the application	
O : non-written disclosure		L : document cited for other reasons	
P : intermediate document		..... & : member of the same patent family, corresponding document	