

12 **EUROPEAN PATENT APPLICATION**

21 Application number: **88304658.3**

51 Int. Cl.4: **A 24 B 5/10**
A 24 B 5/00, B 07 B 13/10

22 Date of filing: **23.05.88**

30 Priority: **22.05.87 ZW 9387**

43 Date of publication of application:
23.11.88 Bulletin 88/47

84 Designated Contracting States: **DE GB IT**

71 Applicant: **Lajtner, Zdravko**
25 Bassett Crescent Alexander Park
Harare (ZW)

72 Inventor: **Lajtner, Zdravko**
25 Bassett Crescent Alexander Park
Harare (ZW)

74 Representative: **Dearing-Lambert, Peter Richard**
Dearing-Lambert & Co. 109 High Street
ibstock Leicestershire LE6 1LJ (GB)

54 **Tobacco classifier.**

57 A tobacco classifier comprises a chamber (10) through which tobacco mixture is thrown by a paddle winnower (11) so that the various constituents of the mixture separate into different receiving bins (18) - (20) to be removed by scavenging conveyors (13) - (16). The classifier, and the method of using it, are characterised by the fact that the classification process is not dependent on the inducement of an air flow through the chamber (10).

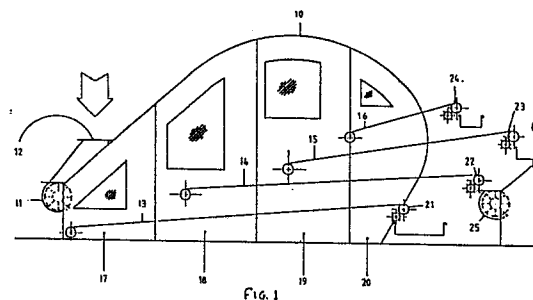

Description

"TOBACCO CLASSIFIER"

This invention relates to the classification of tobacco.

To the knowledge of the Inventor there is at present no proper system for the automatic classification of tobacco. Machinery at present used in the industry can best be described as tobacco separators and most operate according to the following basic principles. Separation is only into light particles and heavy particles by means of air, i.e. the lights or cut lamina are lifted out of the heavies or uncut lamina and stem. The so-called heavies are usually dropped out of the separator.

In general, existing pneumatic tobacco classifiers are loaded and off-loaded by use of centrifugal-type tangential separators. There are a number of disadvantages inherent in the present tobacco separators, not least of which is the inability to separate the heavies, i.e. uncut lamina and stem, into their constituent parts. Therefore, for example, the stem, even though it is a by-product of the process, tends to be carried throughout the process, thus affecting separation efficiency, power absorbed, size of equipment, etc. The uncut lamina is also unnecessarily carried throughout each stage, through a number of separators, thus affecting separation efficiency, power absorbed and increasing degradation of tobacco leaf, etc.

Because one or more fans are required to move air for separation and transport, vastly more power is consumed than would be required for a similar mechanical system. It has been estimated that power consumption may be as much as 14 times higher in such circumstances. There are other, related problems such as for example generation of dust which then requires filtration or bleeding off, high conveying velocities of up to 100 km/h which causes increased degradation of the leaf throughout the process, high noise levels associated with pneumatic systems, heat generated through movement of high volumes of compressed air in a closed circuit system and not least the high maintenance costs due to the relatively complex and expensive machinery.

A representative example of the prior art appears from United States Patent Specification No. 4 465 194 of 14th August 1984. A tobacco leaf separator is illustrated in the customary air separation chamber largely used in the industry.

It is a principal object of this invention to provide true classification in a graduated manner of the threshed tobacco into its constituent parts, thus separating whole tobacco leaves, leaves with attached stem (uncut lamina), pieces of leaf with no stem (lamina) and pieces of stem with no leaf by the use of a combination of inertia, air resistance and gravity, as opposed to the present art which simply separates heavies and lights as above described.

There are a number of significant advantages to be derived from use of the present invention amongst which are the ability to remove the heavies from the process at an early stage.

The heavies will already be divided up into constituent parts, i.e. uncut lamina and stem. The uncut lamina can then be sent for recutting whilst the recovered stem can be removed entirely. As a result a dramatic reduction in the volume of tobacco being presented for further classification will occur in each subsequent classifier which should greatly increase classifier through-put efficiency, reduce degradation of the leaf and reduce both power required and maintenance of machinery.

In accordance with one aspect of the present invention there is provided a tobacco classifier comprising, in working combination, an elongate enclosed chamber having a substantially dome-shaped roof, inlet means located in a lower zone of the chamber adapted for the introduction of tobacco mixture into the classifier, means associated with the inlet means adapted to project tobacco mixture generally upwardly toward the dome of the roof in the direction of elongation of the chamber a plurality of open-topped receiving bins disposed in the chamber positioned and adapted to receive the separated tobacco mixture in its constituent parts and scavenging means associated with said receiving bins adapted to remove the classified tobacco mixture from the chamber characterised in that the said projecting means is arranged and adapted to throw the tobacco mixture through the chamber, the classification thereby effected not being dependent on the inducement of an air flow through the chamber.

The said projecting means may be a paddle-type winnower. The winnower may be articulated so as to permit projection of the tobacco mixture into the chamber along a lower or higher trajectory relative to the horizontal plane and may be articulated in such a way as to permit a degree of lateral projection of the tobacco mixture into the chamber.

The scavenging means may comprise one or more conveyor belts running from a collection zone in a receiving bin to a discharge point external to the classifier chamber.

In accordance with another aspect of the present invention there is provided a method of classifying tobacco mixture into its constituent parts, characterised in that the method comprises utilising one or more tobacco classifiers as defined in the three immediately preceding paragraphs in conjunction with a tobacco processing plant known *per se*.

A preferred embodiment of the invention will now be described by way of example with reference to the accompanying drawing, in which Figure 1 is a schematic side sectional elevation of a tobacco classifier in accordance with the invention.

Referring to Figure 1, reference numeral 10 indicates generally the outline of a classifier chamber and more particularly its dome-shaped roof. Numeral 11 indicates a paddle-type winnower having an inlet 12 for tobacco mixture (not shown) to be introduced into the chamber 10. Numerals 13, 14, 15 and 16 generally indicate conventional conveyors

leading from receiving bins 17, 18, 19 and 20 to discharge points 21, 22, 23 and 24, respectively.

Numerals 25 indicates the inlet of the next classifier in the production line process into which is directed only the separated materials requiring further processing, whilst remaining materials may be directed out of the production line at this stage.

The classifier works without any induced airflow within the chamber 10 by relying upon the relatively low mass and poor aerodynamics of the tobacco mixture. The result is that the lighter and less aerodynamic particles will settle first and be collected into bin 17, whilst progressively heavier and more aerodynamic materials will separate out into successive bins and may then be removed by the various conveyors 13, 14, 15 and 16 as required.

An essential improvement in the classifier of the invention over all prior art known to the inventor is the removal of any specific need to create within the classification chamber any form of air stream, and this has resulted in significant savings in machinery wear and tear and in power consumption, all of which are significant factors to the users of such classifiers. It is believed that the classifier herein disclosed represents a substantial advance in the state of the art in its restricted application.

Claims

1. A tobacco classifier comprising, in working combination, an elongate enclosed chamber (10) having a substantially dome-shaped roof, inlet means (12) located in a lower zone of the chamber (10) adapted for the introduction of tobacco mixture into the classifier, means (11) associated with the inlet means (12) adapted to project tobacco mixture generally upwardly toward the dome of the roof in the direction of elongation of the chamber (10), a plurality of open-topped receiving bins (17) - (20) disposed in the chamber (10) positioned and adapted to receive the separated tobacco mixture in its constituent parts and scavenging means (13) - (16) associated with said receiving bins (17) - (20) adapted to remove the classified tobacco mixture from the chamber (10), characterised in that the said projecting means (11) is arranged and adapted to throw the tobacco mixture through the chamber (10), the classification thereby effected not being dependent on the inducement of an air flow through the chamber (10).

2. A tobacco classifier as claimed in claim 1, characterised in that the said projecting means (11) is a paddle-type winnower (11).

3. A tobacco classifier as claimed in claim 2, characterised in that the winnower (11) is articulated so as to permit projection of the tobacco mixture into the chamber (10) along a lower or higher trajectory relative to the horizontal plane.

4. A tobacco classifier as claimed in claim 2 or

claim 3, characterised in that the winnower (11) is articulated in such a way as to permit a degree of lateral projection of the tobacco mixture into the chamber (10).

5. A tobacco classifier as claimed in any one of the preceding claims, characterised in that the scavenging means (13) - (16) comprises one or more conveyor belts running from a collection zone in a receiving bin (17) - (20) to a discharge point (21) - (25) external to the classifier chamber (10).

6. A method of classifying tobacco mixture into its constituent parts, characterised in that the method comprises utilising one or more tobacco classifiers as claimed in any one of the preceding claims in conjunction with a tobacco processing plant known per se.

5
10
15
20
25
30
35
40
45
50
55
60
65

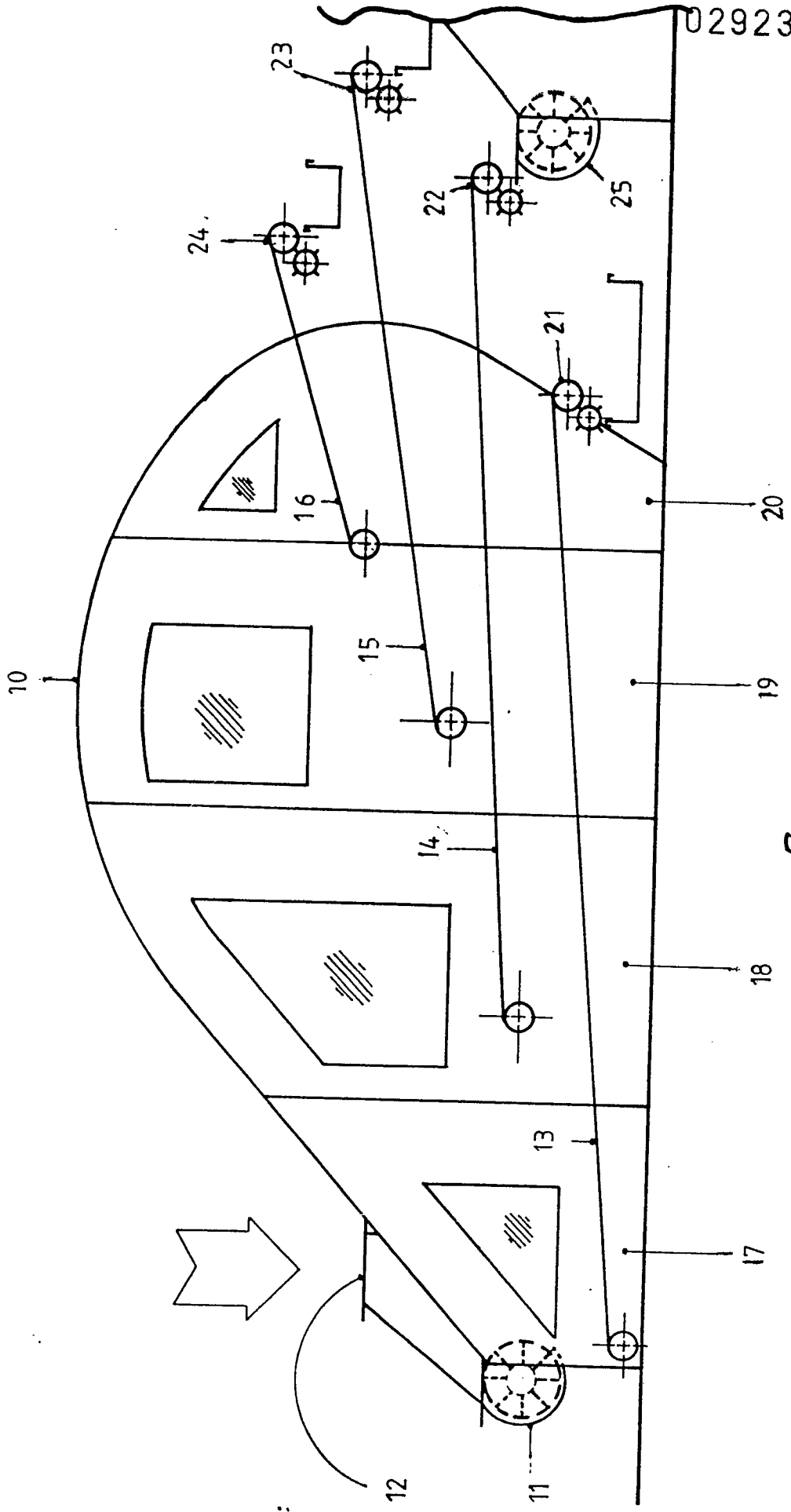

FIG. 1



DOCUMENTS CONSIDERED TO BE RELEVANT			
Category	Citation of document with indication, where appropriate, of relevant passages	Relevant to claim	CLASSIFICATION OF THE APPLICATION (Int. Cl.4)
D, Y	US-A-4 465 194 (COLEMAN) * Figures 1-2; abstract * ----	1-5	A 24 B 5/10 A 24 B 5/00 B 07 B 13/10
Y	FR-A- 589 236 (SOCIETE ANONYME DES ATELIERS ARMAND ET DEOUNE) * Whole document * ----	1-5	
A	WO-A-7 900 168 (HJELM) * Figure 1; abstract * ----	1-2	
A	US-A-3 757 800 (HARRY DAVID) * Figure; column 4, line 63 - column 5, line 45 * -----	1	
			TECHNICAL FIELDS SEARCHED (Int. Cl.4)
			A 24 B B 07 C B 07 B
The present search report has been drawn up for all claims			
Place of search THE HAGUE		Date of completion of the search 05-09-1988	Examiner RIEGEL R. E.
CATEGORY OF CITED DOCUMENTS		T : theory or principle underlying the invention E : earlier patent document, but published on, or after the filing date D : document cited in the application L : document cited for other reasons ----- & : member of the same patent family, corresponding document	
X : particularly relevant if taken alone Y : particularly relevant if combined with another document of the same category A : technological background O : non-written disclosure P : intermediate document			