

12

EUROPEAN PATENT APPLICATION

21 Application number: 88108691.2

51 Int. Cl.4: E04H 3/18

22 Date of filing: 31.05.88

30 Priority: 01.06.87 JP 134979/87

43 Date of publication of application:
07.12.88 Bulletin 88/49

64 Designated Contracting States:
DE ES FR GB IT

71 Applicant: **NIPPON KOKAN KABUSHIKI
KAISHA**
1-2 Marunouchi 1-chome Chiyoda-ku
Tokyo 100(JP)

72 Inventor: **Kodan, Norihisa c/o Patent &
License and
Quality Stand.Dep. Nippon Kokan K.K. 1-2,
1-chome
Marunouchi Chiyoda-ku Tokyo(JP)**

74 Representative: **Füchsle, Klaus, Dipl.-Ing. et al
Hoffmann . Eitle & Partner Patentanwälte
Arabellastrasse 4
D-8000 München 81(DE)**

54 **Wave making apparatus.**

57 Wave making apparatus comprises: a wave generating plate (12) having a wave generating face (13) inclined toward the center of a wave pool relative to the stationary surface of water (22) in the wave pool and a device moving said wave generating plate (12) along a wall (18) inclined upward and backward relative to the center of the wave pool. A drive unit has a drive shaft (14) provided with the wave generating plate (12), a mount (16) supporting the drive shaft (14) and a drive device moving the wave generating plate (12) along the wall (18) through the drive shaft (14). The wave generating plate (12) is inclined toward the center of the wave pool at an angle of 10° to 40° relative to the vertical plane. The wall (18) is inclined backward relative to the center of the wave pool at an angle of 30° to 50° relative to the vertical plane.

FIG.1

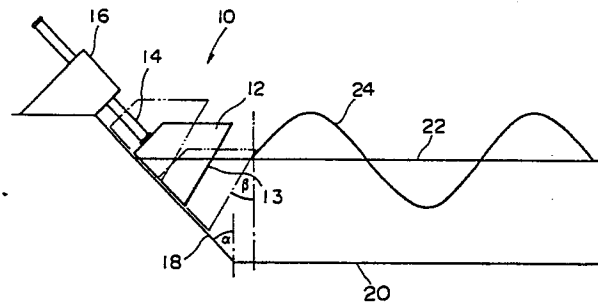

EP 0 293 831 A1

Wave Making Apparatus

The present invention relates to a wave making apparatus used in a wave pool for recreation.

More prior art wave making apparatus used in pools for recreation have been of the flap or air type. The wave making apparatus used in experimental tanks are mainly of the flap, plunger or piston type. The flap-type wave making apparatus drives the upper end of a flap, in a horizontal direction, the flap being held with a pin at the lower end in a freely rotatable state, and generates waves by oscillating the flap with a centered pin. The air-type wave making apparatus sends air into an air chamber by means of a blower and fluctuates the level of water by opening and closing a duct set in the air chamber, to thereby generate waves. The plunger-type wave making apparatus moves a wedge-shaped plunger held at the lower end of a shaft up and down along a tank wall standing vertically, to thereby generate waves in the water. The piston-type wave making apparatus moves a flap set vertically relative to the surface of the water on a rod, back and forth along a tank bottom, to thereby generate waves in the water.

The flap-type wave making apparatus, one of the abovementioned conventional wave making apparatus, produces a larger turbulence near the surface of water and a smaller turbulence under water as it goes deeper, because the flap is held at the lower end with a pin. To generate high waves, therefore, it is necessary to increase the height of the flap greatly. In addition, to absorb the waves generated behind the flap, it is necessary to provide a certain distance between the back of the flap and the tank wall, and a special wave absorbing device or a special wave absorbing construction is required. Although a method wherein air exists instead of water behind the flap is partly put to practical use, this method requires an intricate mechanism.

The air-type wave making apparatus has difficulties in that it requires a complicated control of a blower, and a complicated mechanism for controlling the opening and closing of a duct due to the compressibility of air to generate high waves.

The plunger-type wave making apparatus produces a smaller turbulence in a deep zone of the water than near the surface of the water because the plunger as a wave generating plate is wedge-shaped. To generate high waves, therefore, it is necessary to increase the stroke of the wave generating plate. This disadvantageously leads to a great size of the wave generating plate.

The piston-type wave making apparatus requires a certain distance to be provided between the back of the wave generating plate and the tank

wall, and a special wave absorbing device or a special wave absorbing construction is required in order to absorb the waves produced behind the wave generating plate.

It is an object of the present invention to provide wave making apparatus which is able to easily generate high waves and which requires neither special wave absorbing devices nor a special wave absorbing construction.

In accordance with the present invention, a wave generating apparatus comprises a wave generating plate having a wave generating face inclined toward the center of a wave pool relative to the stationary surface of water of the wave pool; and means for driving the wave generating plate along a wall which is inclined backward relative to the center of the wave pool.

The above objects and other objects and advantages of the present invention will become apparent from the detailed description to follow, taken in connection with the appended drawings.

Fig. 1 is an explanatory view illustrating a first embodiment of a wave making apparatus according to the present invention;

Fig. 2 is an explanatory view illustrating another embodiment of a wave making apparatus of the present invention;

Fig. 3 is an explanatory view illustrating still another embodiment of a wave making apparatus of the present invention;

Fig. 4 is a plan view illustrating a pool used with the wave making devices of the present invention;

Fig. 5 is a cross-sectional view of the present invention taken on the plane of line 2-2 of Fig. 4; and

Fig. 6 schematically shows a hydraulic drive for the wave generating plate of the invention.

The wave making apparatus of the present invention comprises a wave generating plate which is driven along a pool wall so that waves can not be generated behind the wave generating plate if high waves are generated. In this case, the pool wall, along which the wave generating plate slides, is inclined so that turbulence can be produced in a deeper zone of water.

Fig. 1 is an explanatory view illustrating one embodiment of a wave making apparatus 10 of the present invention. Wave making apparatus 10 comprises a wave generating plate 12 having a wave generating face 13 (front face of wave generating plate 12) which is inclined forward relative to the stationary upper surface of the water 22 and means for driving wave generating plate 12 along wall 18, wall 18 being inclined backward relative to the

center of the wave generating pool. The drive means for plate 12 has a drive shaft 14 coupled to the wave generating plate 12, a mount 16 holding the drive shaft 14, and a drive unit (not shown, but arranged in mount 16) driving wave generating plate 12 along wall 18 through the drive shaft 14. To move wave generating plate 12 along wall 18, drive shaft 14, coupled to the wave generating plate 12, and mount 16 holding the drive shaft 14, are arranged so that drive shaft 14 and mount 16 have the same incline as that of wall 18.

It is preferable to incline wall 18 backward relative to the center of the wave pool at an angle α of 30° to 50° relative to the vertical plane. If the wall 18 is inclined at less than 30° , smaller turbulence is produced in a deeper zone of water. If the wall is inclined at more than 50° , the wave generating plate 12 will be required to be too large.

A minimum clearance between wave generating plate 12 and wall 18 is sufficient to permit moving of the wave generating plate 12. If necessary, a slide guide can be provided between wave generating plate 12 and wall 18 in order to carry the partial weight or buoyancy of wave generating plate 12.

The lower end of wave generating plate 12 is positioned at a height above pool bottom 20 which is equal to about one-half of the stroke or greater than the stroke necessary to generate waves of desired height. The upper end of front face 13 of wave generating plate 12 is positioned at a height such that water does not splash over the top of wave generating plate 12 when waves of desired height are generated.

Wave generating face 13 of wave generating plate 12 is inclined toward the center of the pool, i.e., inclined forward relative to the stationary upper surface 22 of the water, to generate a wave 24 moving toward the center of the pool. The wave generating face 13 of the wave generating plate 12 is desired to be inclined toward the center of the pool at an angle β of 10° to 40° relative to the vertical plane. The wave generating face 13 need not be flat; it may be curved, either convex or concave. The bottom face of wave generating plate 12 is parallel to inclined wall 18. The top face of wave generating plate 12 and the surface on which drive shaft 14 is mounted have no restriction on shape or orientation. In the embodiment of Fig. 1, wave generating plate 12 of a block shape having a rectangular section is used, but the wave generating plate 12 is not confined to the abovementioned shape. It is sufficient that the wave generating plate 12 has a wave generating face 13 which is inclined forward. A wave generating plate 12 comprising a wave generating face, bottom face and an upper face and a wave generating plate of a shape of a thin plate having only a wave generating face can

be used.

A drive means for wave generating plate 12 comprises drive shaft 14 connected to wave generating plate 12, mount 16 holding the drive shaft and a drive unit (not shown) for driving the wave generating plate along wall 18 through said drive shaft. The drive unit coupled to drive shaft 14 may be hydraulic, pneumatic or electrical. The chain lines in Fig. 1 show the wave generating plate 12 in different positions, as driven by the drive means.

According to the wave making apparatus described above, when the wave generating plate 12 is pushed into the water by being moved half a stroke downward along wall 18 by the drive unit through drive shaft 14, wave generating face 13 of wave generating plate 12 produces turbulence down to the deep zone in the water, thereby generating waves of desired height. Such generation of the waves by means of wave generating plate 12 is carried out each time wave generating plate 12 is pushed into the water by being moved downward after being moved upward. Thus, wave 24 being generated continuously.

Fig. 2 is an explanatory view illustrating another Embodiment of a wave making apparatus of the present invention. The wave making apparatus of Fig. 2 comprises a hydraulic actuator which moves drive shaft 14' supported by mount 16'. A pneumatic actuator can be used as a drive unit in place of a hydraulic actuator. In other respects, the embodiment of Fig. 2 is the same as that of Fig. 1. A typical hydraulic drive unit is shown in Fig. 6, and is described below.

Referring to Fig. 6, the wave generating plate is reciprocally mounted on guiding rods 47, which pass through openings or apertures in wave generating plate 12. The guiding rods are fixedly secured to inclined wall 18 by means of respective mounting members 48. Hydraulic actuators 16' actuate respective drive shafts 14', which are connected to the wave generating plate 12, as shown in Fig. 6. Hydraulic actuators 16' are mounted to the upper surface of the pool by means of respective mounting members 46. The wave generating plate 12 is driven along the guiding rods 47 by means of the hydraulic actuators 16' in a reciprocating manner. The hydraulic actuators 16' are coupled to a source of hydraulic fluid (not shown), and to a control device to control the supply of the hydraulic fluid to operate the actuators to reciprocally drive the wave generating plate 12.

Fig. 3 is an explanatory view illustrating still another embodiment of the wave making apparatus of the present invention. In this embodiment, a drive means comprises a drive shaft 34 connected to the wave generating plate 12, the drive shaft 34 having a rack 26 thereon. The drive means further comprises a pinion gear 28 engaged with the rack

26. A drive motor 35 is coupled to drive pinion gear 28, preferably through a reduction gearing (not shown). Mount 36 supports the drive shaft 34 and the drive motor 35 coupled to turn the pinion gear 28 for driving the wave generating plate 12 along a wall through the rack gear 26 on the drive shaft 34. In other respects, the embodiment of Fig. 3 is similar to that of Fig. 1.

An example of the wave making apparatus arranged in a pool for surfing is shown in Figs. 4 and 5. Fig. 4 is a plan view illustrating the pool used in the surfing pool example of the invention. Fig. 5 is a cross-sectional view taken on the plane of line 2-2 of Fig. 4. The pool of Fig. 5 includes two wave making apparatuses 10a and 10b, which are the wave making apparatus 10 shown in Fig. 1. In Fig. 4, the distance from the bottom of pool 30 to the top surface of the water is indicated in parentheses. The bottom surface of pool 30 is lowest in the central area and slopes up toward the pool sides. A wave making apparatus of the present invention was arranged at each end of two waterways 32a and 32b which are connected to pool 30. The waves generated by wave making apparatuses 10a and 10b pass through the two respective waterways 32a and 32b and cross each other in pool 30. As a result, high waves appropriate for surfing can be generated easily in pool 30, by means of the wave making apparatuses 10a and 10b. In the case of a wave making pool for surfing, the form of wave 24 need not be sinusoidal. Waves 24 of high steepness ratio, which have peaked crests and flat troughs, are preferable. The drive unit for driving the wave generating plate 12 is not required to have a sophisticated sinusoidal motion control mechanism. A drive cycle range which cover a very limited range of the cycle is sufficient.

In a test example, the backward angle of inclination α of the wall 18 was at 45° , and the angle of inclination β of the wave generating face 13 of the wave generating plate 12 was set at 30° . The reciprocating cycle of operation of the wave generating plate was between 2 and 6 seconds. The design criteria for the stroke of the wave generating plate (distance of movement) for a given depth of water is as follows:

$$\text{Wave Height} \doteq (0.5 - 0.7) \times \text{Depth of Water}$$

$$\text{Stroke} \doteq 1.4 \times \text{Wave Height}$$

Consequently, $\text{Stroke} \doteq (0.7 - 1.0) \times \text{Depth of Water}$

The improved effects of the present invention are as follows:

(a) The wave making apparatus of the present invention can produce turbulence in a deep zone of water in comparison with prior art wave making apparatus. Therefore, high waves can be easily generated.

(b) Any special wave absorbing work is not required because there is no surface of water behind the wave generating plate. Accordingly, the space around the wave making apparatus which is necessary for arranging said apparatus is reduced and, therefore, maneuverability for arranging the wave making apparatus increases.

While the invention has been described above with respect to specific apparatus, it should be clear that various modifications and alternations can be made within the scope of the invention as defined in the appended claims. For example, the drive means for driving the wave generating plates can be freely chosen, to drive the wave generating plate 12, forward and backward (that is, "to and fro", substantially parallel to the surface of the rearwardly inclined surface 18 of the pool.

20 Claims

1. A wave making apparatus for use in a wave pool comprising:

a wave generating plate (12) having a wave generating face (13) which is inclined toward the center of a wave pool relative to a stationary upper surface (22) of water in said wave pool, characterized by drive means for driving said wave generating plate along a wall (18) which is upwardly and backwardly inclined relative to the center of the wave pool.

2. The wave making apparatus of claim 1, characterized in that said drive means drives said wave generating plate (12) in parallel to said upwardly and backwardly inclined wall (18) of said wave pool.

3. The wave making apparatus of claim 1, characterized in that said drive means comprises:

a drive shaft (14) coupled to said wave generating plate (12);

mount means (16) for supporting said drive shaft (14) relative to said upwardly and backwardly inclined wall (18); and

drive unit means for driving said wave generating plate (12) along said upwardly and backwardly inclined wall (18) through said drive shaft (14).

4. The wave making apparatus of claim 3, characterized in that said drive unit means includes a hydraulic drive unit.

5. The wave making apparatus of claim 3, characterized in that said drive unit means includes a pneumatic drive unit.

6. The wave making apparatus of claim 3, characterized in that said drive unit means includes an electric motor drive unit.

7. The wave making apparatus of claim 1, characterized in that said drive means comprises:

a drive shaft (34) coupled to said wave generating plate (12) and having a rack gear (26) thereon;

5

mount means (36) for supporting said drive shaft (34) relative to said upwardly and backwardly inclined wall (18); and

drive unit means including a pinion gear (28) engaged with said rack gear (26) for moving said wave generating plate (12) along said upwardly and backwardly inclined wall (18) through said pinion gear (28) and said drive shaft (34).

10

8. The wave making apparatus of claim 1, characterized in that said wave generating plate (12) comprises a wave generating face (13) which is inclined toward the center of the wave pool at an angle of 10° to 40° relative to a vertical plane.

15

9. The wave making apparatus of claim 8, characterized in that said upwardly and backwardly inclined wall (18) is inclined backward relative to the center of the wave pool, at an angle of 30° to 50° relative to a vertical plane.

20

10. The wave making apparatus of claim 1, characterized in that said upwardly and backwardly inclined wall (18) is inclined backward relative to the center of the wave pool, at an angle of 30° to 50° relative to a vertical plane.

25

11. The wave making apparatus of claim 1, characterized in that said wave generating plate (12) comprises a wave generating face (13) which is inclined toward the center of the wave pool at an angle of about 30° .

30

12. The wave making apparatus of claim 8, characterized in that said upwardly and backwardly inclined wall (18) is inclined backward relative to the center of the wave pool, at an angle of about 45° .

35

13. The wave making apparatus of claim 1, characterized in that said upwardly and backwardly inclined wall (18) is inclined backward relative to the center of the wave pool, at an angle of about 45° .

40

45

50

55

5

FIG. 1

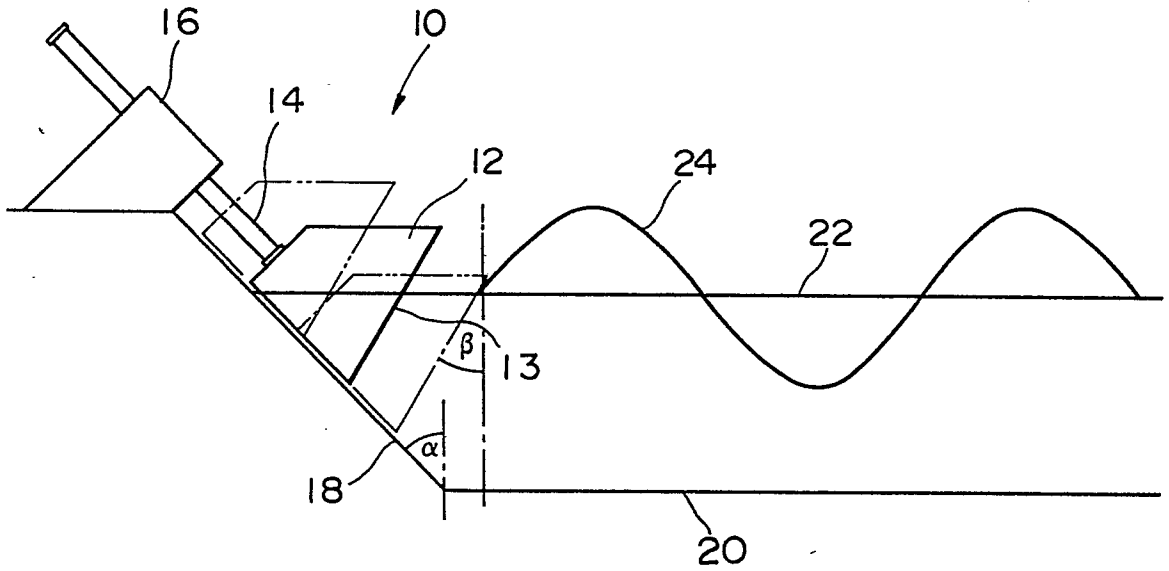
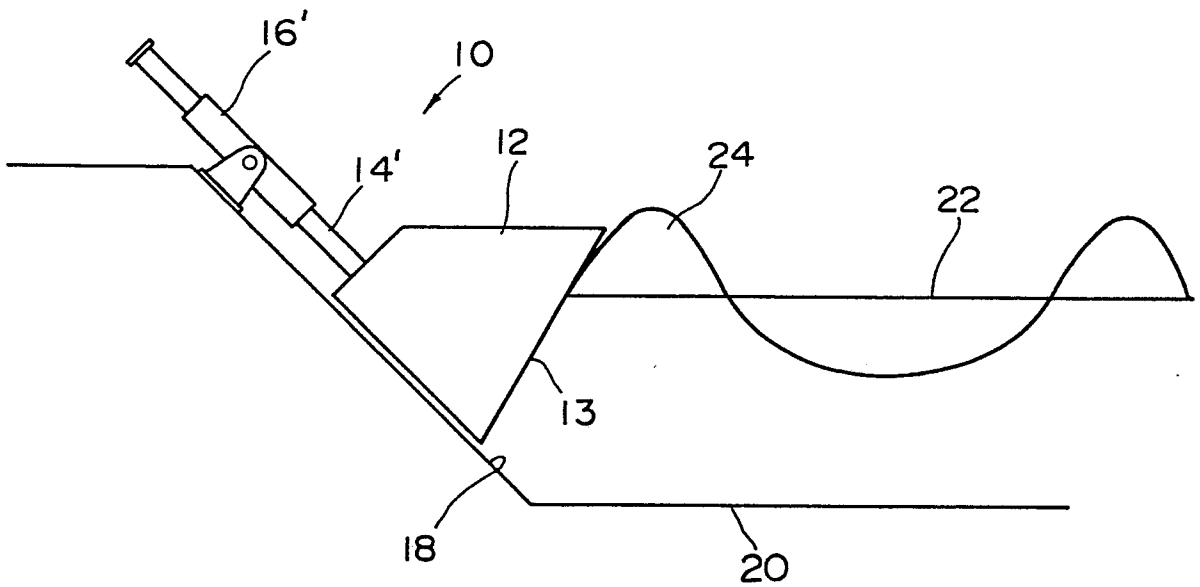

FIG. 2



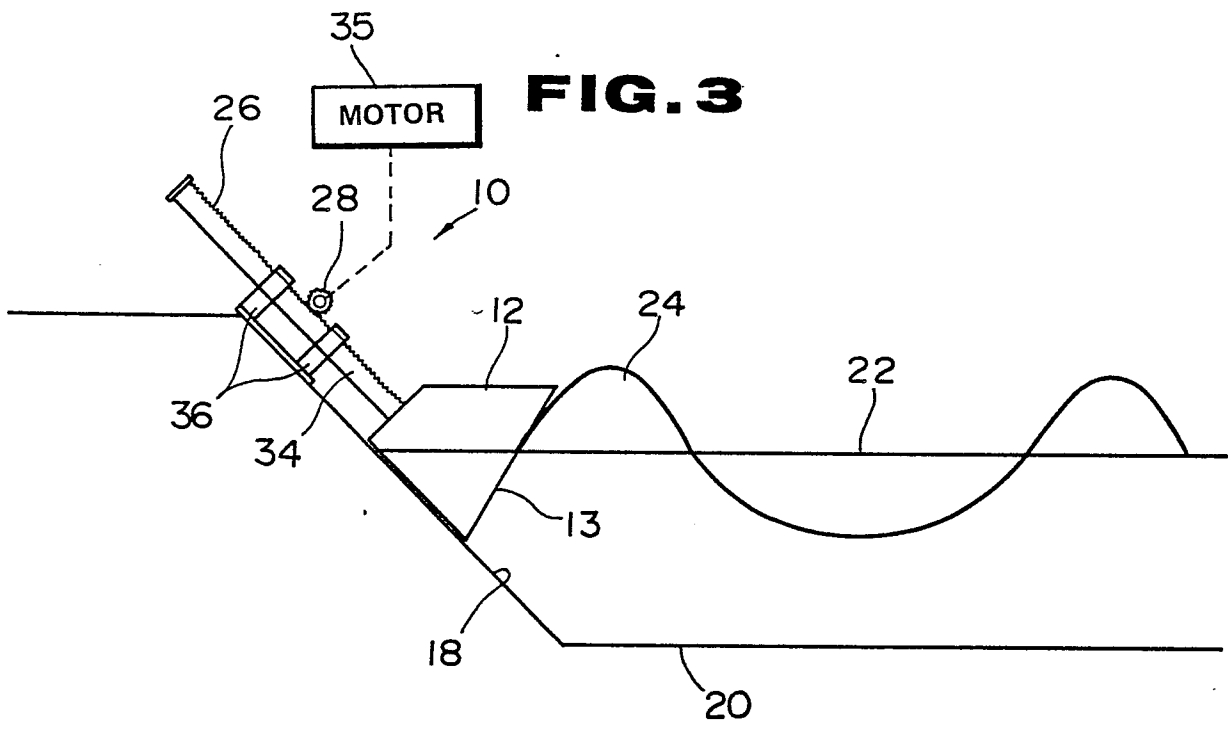

FIG. 4

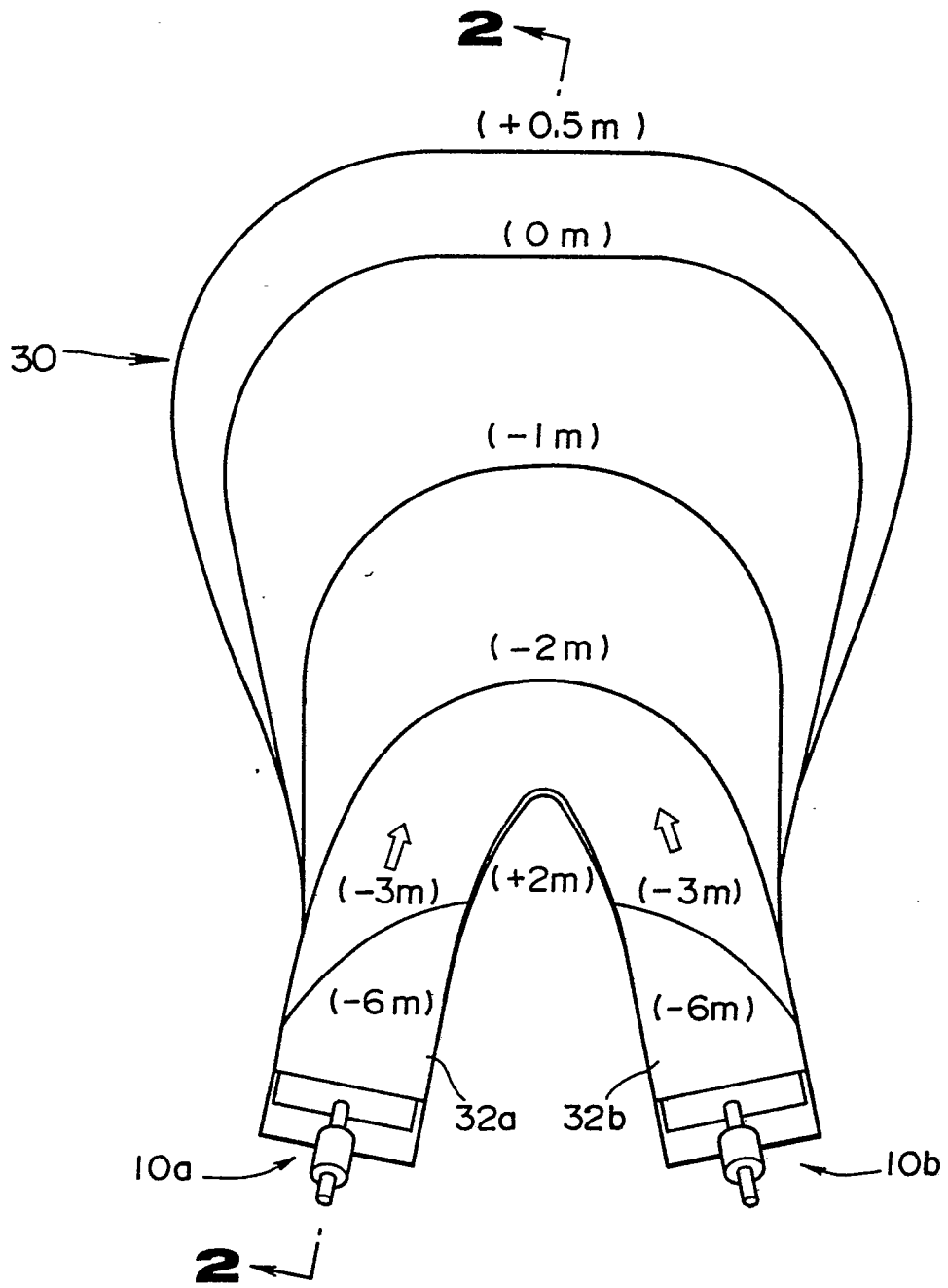

FIG. 5

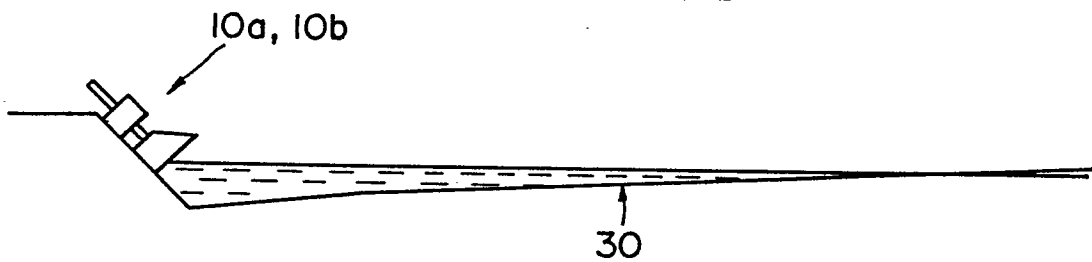
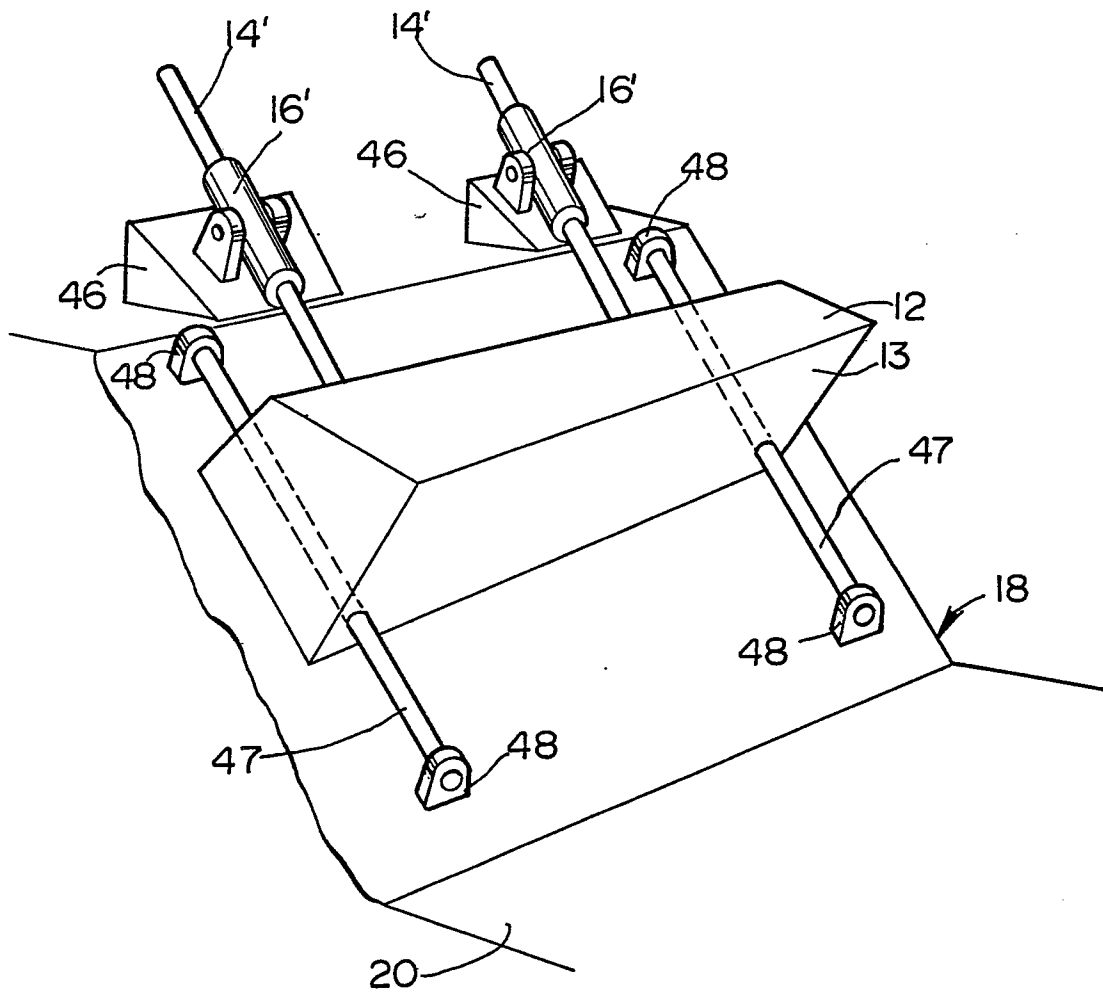

FIG. 6





DOCUMENTS CONSIDERED TO BE RELEVANT			
Category	Citation of document with indication, where appropriate, of relevant passages	Relevant to claim	CLASSIFICATION OF THE APPLICATION (Int. Cl.4)
X	FR-A-2 291 803 (ALSTHOM) * Page 3, line 33 - page 4, line 14; figures 1-2 *	1-3,8-13	E 04 H 3/18
Y	----	4-7	
Y	US-A-3 350 724 (LEIGH) * Column 3, lines 22-27; figure 2 *	4-6	
Y	US-A-3 005 207 (MATRAI) * Column 2, lines 57-71; figure 5 *	7	
A	GB-A-1 592 452 (INDUSTRIAL & COMMERCIAL ELECTRONICS LTD) * Page 1, lines 7-30; figure 1c *	1,6	
			TECHNICAL FIELDS SEARCHED (Int. Cl.4)
			E 04 H F 04 D
The present search report has been drawn up for all claims			
Place of search THE HAGUE		Date of completion of the search 30-08-1988	Examiner PORWOLL H. P.
CATEGORY OF CITED DOCUMENTS X : particularly relevant if taken alone Y : particularly relevant if combined with another document of the same category A : technological background O : non-written disclosure P : intermediate document T : theory or principle underlying the invention E : earlier patent document, but published on, or after the filing date D : document cited in the application L : document cited for other reasons & : member of the same patent family, corresponding document			