

12

EUROPEAN PATENT APPLICATION

21 Application number: 88305837.2

51 Int. Cl.4: **E03D 5/012 , F04B 9/14**

22 Date of filing: 24.06.88

30 Priority: 27.06.87 GB 8715150
28.10.87 US 114450

43 Date of publication of application:
04.01.89 Bulletin 89/01

64 Designated Contracting States:
AT BE CH DE ES FR GB GR IT LI LU NL SE

71 Applicant: **PORTASILO LIMITED**
Huntington
York YO3 9PR(GB)

72 Inventor: **Parkinson, Brian**
15 The Croft
Sherriff Hutton, York YO6 1PQ(GB)
Inventor: **Bishop, Angus John,**
11 Ramsey Avenue
Bishopthorpe, York YO2 1SQ(GB)
Inventor: **Tagg, Richard Leach**
Ringshall House
Sand Hutton, York(GB)

74 Representative: **Lally, William et al**
FORRESTER & BOEHMERT
Widenmayerstrasse 4/1
D-8000 München 22(DE)

54 Pump.

57 A pump (32) comprising a flexible member (65) defining at least part of a variable volume pumping chamber, an inlet valve (34) to permit of liquid to enter the chamber thereby and an outlet valve (39) to permit of liquid to leave the chamber thereby, operating means (64) to deform the flexible member (65) from an initial condition and resilient biasing means to return the flexible member (65) towards the initial condition to vary the volume of the pumping chamber to pump liquid into and out of the chamber wherein the resilient biasing means comprises a fluid containing unit in which relative movement of solid elements of the unit occurring on movement of the flexible member (65) from the initial condition is directly resisted by elastic deformation of the fluid and the resilient energy stored in the fluid causes return movement of the solid elements to move the flexible member (65) towards the initial condition.

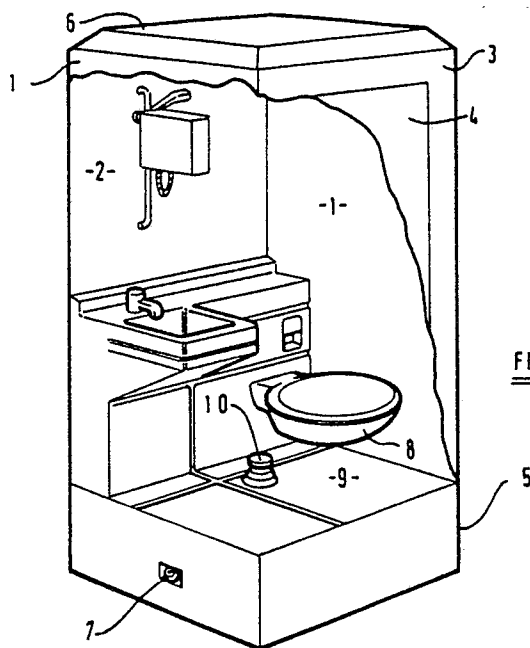

FIG 1

EP 0 297 812 A1

"Pump"

This invention relates to a pump particularly, but not exclusively, for pumping liquid to flush a sanitary pan or for pumping water to a discharge means associated with a sink for hand washing purposes or to a shower head. The invention also relates to a reservoir and a pump in combination to provide a self-contained liquid or water supply and pumping capability. The invention also relates to cabins, huts and like accommodation units housing at least one sanitary pan and/or sink and/or shower head for use on building sites, exhibition grounds, camp site car parks and the like, i.e. in all manner of circumstances where sanitary facilities of a permanently installed nature are not available but where such facilities must nevertheless be provided for use of site workers and others, and provided with a pump for pumping liquid to flush the sanitary pan or to pump water to a discharge means associated with the sink, or to the shower head.

According to the invention we provide a pump comprising a movable member defining at least part of a variable volume pumping chamber, an inlet valve to permit of liquid to enter the chamber thereby and an outlet valve to permit of liquid to leave the chamber thereby, operating means to move the movable member from an initial condition and resilient biasing means to return the movable member towards the initial condition to vary the volume of the pumping chamber to pump liquid into and out of the chamber wherein the resilient biasing means comprises a fluid containing unit in which relative movement of solid elements of the unit occurring on movement of the movable member from the initial condition is directly resisted by elastic deformation of the fluid and the resultant energy stored in the fluid causes return movement of the solid elements to move the movable member towards the initial condition.

The movable member may comprise a flexible member and the operating member may deform the flexible member from said initial condition and the resilient means may move the flexible member towards the initial condition.

The fluid containing unit may comprise a chamber with a flexible wall or a piston and cylinder in mutual sliding contact or a piston supported in a cylinder of substantially large diameter than the piston and sealed thereto by means of an over-sized annular diaphragm which performs a rolling motion during said relative movement of the solid elements of the unit.

The resilient biasing means may comprise first and second telescopically slidable members, a first of said members being fixed to a base part of the

pump to which the flexible member is also attached at one end and the operating means and the other end of the flexible member being connected to the second member of the resilient biasing means.

The flexible member may be connected to the second member by an operating link which extends from the flexible member to a position adjacent the upper end of the second member adjacent which the operating link is connected to the operating member and to the second member.

According to a second aspect of the invention we provide a pump comprising a movable member defining at least part of a variable volume pumping chamber, an inlet valve to permit of liquid to enter the chamber thereby and an outlet valve to permit of liquid to leave the chamber thereby and operating means to move the movable member to vary the volume of the pumping chamber to pump liquid into and out of the chamber wherein a guide means is provided to guide the movable member during said deformation.

The movable member may comprise a flexible member and the operating member may deform the flexible member from said initial condition and the resilient means may move the flexible member towards the initial condition.

The guide means may guide the operating member.

The guide means may comprise a first and second slidably related members, a first of said members being fixed to a base part of the pump to which the flexible member is also attached to one end and the operating means and the other end of the flexible member being connected to the second member.

The flexible member may be connected to the second member by an operating link which extends from the flexible member to a position adjacent the upper end of the second member adjacent which the operating link is connected to the operating member and to the second member.

The first and second slidably related members may be telescopically slidable one within the other.

Where the flexible member is connected to the second member by an operating link and second member may be telescopically slidable within the first member and the operating link may be telescopically disposed around the first member.

In one more specific aspect of the invention the pumping chamber may be disposed within a receptacle, the receptacle including a wall through which the operating means passes so that an operating member is disposed externally of the receptacle and the pumping chamber internally of the recepta-

cle, and the receptacle is adapted to be positioned at least partly within a reservoir for liquid to be pumped and the receptacle is adapted to permit passage of liquid to the interior thereof from such reservoir.

The reservoir may be provided with an opening through which said receptacle extends and the opening being closed by the wall of the receptacle through which the operating means passes.

The receptacle may be replaceably mounted at least partly within said reservoir.

Accordingly it is simple to remove the pump, for example, for repair or servicing simply by removing the receptacle from the container.

The pump may be operatively connected to a sanitary pan to flush the pan with liquid withdrawn from a region of said reservoir which is separated by a filter screen from another region thereof into which the sanitary pan discharges.

Alternatively the pump may be connected to a discharge outlet associated with a sink for hand washing purposes to pump water to the discharge outlet. Further, alternatively, the pump may be connected to a shower head so as to pump water to the shower head.

The invention provides a self-contained liquid pumping facility which may be used in a wide variety of applications such as to flush a w.c. or "head" in a boat or a w.c. in a coach, train, aeroplane or the like or to provide a water supply to a wash basin or shower in a boat, coach, train or aeroplane or the like. If desired the reservoir may comprise two reservoirs, the contents of which are kept separate and there being two pumps, one to pump liquid for w.c. sanitary pan flushing and the other to pump clean water for washing or showering.

The pump may be disposed in said reservoir so as to be at least partially immersed in the liquid, in use.

In a second more specific aspect of the invention the flexible member may define at least a majority of the variable volume pumping chamber and the pump may be operatively connected to a sanitary pan so as to pump liquid to flush the pan.

In both of the more specific aspects of the invention the sanitary pan may be housed in a cabin, hut or like accommodation unit, the unit having a wall structure mounted on a base structure, the base structure defining, the or a, reservoir, the reservoir being for the reception of a suitable chemical liquid, and the sanitary pan being arranged to discharge into the liquid in use.

The receptacle may be provided with an impermeate wall on the side thereof adjacent to the discharge of the sanitary pan to the reservoir and is provided with a perforate wall, which comprises said filter screen, on the other side thereof.

Said filter screen may be arranged only to surround the inlet to the pump, the sanitary pan being arranged to discharge to a region external to said screen, which may be regarded as being on the "soil side" of the filter screen, whilst the inlet to the pump is disposed internally of filter screen and may be regarded as being on the "clear side" thereof.

Alternatively, said filter screen may be arranged to divide said chamber into two regions of comparatively large volume, the sanitary pan being arranged to discharge into one such region, which may be regarded as being on the "soil side" of the filter screen, whilst the inlet to the pump is disposed on the other side of the filter screen and may be regarded as being on the "clear side" thereof.

In either case, upon each operation of the pump to draw chemical liquid from the "clear side" of the reservoir such liquid will be replaced by liquid drawn through the filter screen from the "soil side" thereof.

The pump of the present invention, by virtue of being disposed so that it is at least partially immersed in the liquid in the tank and by arranging that the fluid level in the tank is at an appropriate level, an adequate amount of liquid to flush the sanitary pan can be achieved with one or, at most, two strokes of the operating member. Moreover, because the pump does not have a piston slidable within a cylinder, no problems arise due to jamming of the piston or of leakage due to wear or failure of a seal between the piston and cylinder. The pump is, therefore, extremely reliable and effective in use.

The reservoir for the chemical liquid forms part of the structure of the unit rather than being a separate fitting as when a conventional chemical closet is mounted in the structure in which it is to be employed; such an arrangement makes for simpler and thus cheaper construction.

A unit according to the invention may house more than one sanitary pan, in separate cubicles; in these circumstances each pan could, if desired, be associated with its own individual reservoir for chemical liquid or alternatively two or more pans could be associated with the same reservoir but in either case each pan would have its own pump.

In one embodiment of the invention which is a unit housing only one sanitary pan, the whole base structure of the unit is in the form of a hollow box defining said reservoir for the chemical liquid, the top closure of such box forming the floor within the unit and being provided with an opening through which said receptacle extends. The box as a whole constitutes a plinth-like base structure on which the wall structure of the unit is mounted. However, in larger units according to the invention housing two

or more sanitary pans, and possibly other sanitary fittings such as urinals and wash basins in addition, the reservoir or reservoir into which such pans discharge need not necessarily occupy the whole of the base structure of the unit but rather may extend only between the cubicles containing the sanitary pans. Where the unit has only one sanitary pan it may be provided with a wash basin or urinal and a pump according to the invention may be provided to pump appropriate liquid thereto.

Means are provided for emptying the chamber at suitable intervals and such means may, if desired, comprise a discharge opening enclosed by a suitable valve mechanism within the chamber. An overflow pipe may be provided in said chamber having its inlet on the clear side of the filter screen and its outlet connected directly to the chamber emptying outlet. Means may be provided for heating the interior of the chamber to prevent freezing of the chemical liquid such as an electrical heater or a calor gas or paraffin fuel heater.

The sanitary pan may be provided with a liquid seal in its discharge, for example, by providing a conventional U-bend in which liquid is trapped.

The pump of the present invention pumps sufficient liquid to permit of breaking of the seal provided by the U-bend so that a conventional flushing and sewage discharge operation is provided.

Alternatively, the sanitary pan may be provided with a flap valve in its discharge which flap valve is operable by the liquid pumped by the pump.

A suitable chemical liquid for use in units according to the invention is one such as is conventionally used in chemical closets, which functions both as a disinfectant and to breakdown solid excreta.

The pumping chamber may also be defined by a fixed volume rigid body on which the flexible member is mounted so as together to define the pumping chamber.

The rigid body may provide said base.

The inlet and outlet valves may be provided on the rigid body.

The inlet valve may comprise a flexible diaphragm movable into and out of sealing engagement with an inlet opening in a part of the body.

The outlet valve may comprise a valve member, such as a ball, movable into and out of sealing engagement with a valve seat surrounding an outlet opening in a part of the body.

The flexible member may be generally cylindrical having a generally cylindrical wall which may be closed at one end and open at the other where it is connected to the body.

The generally cylindrical wall may have a corrugated configuration to provide a collapsible bellows.

The fluid containing unit may comprise a piston and cylinder in mutual sliding contact, the piston having opposed surfaces of different operative areas and there being a passageway for restricted flow of fluid between said opposed surfaces of the piston.

An embodiment of the invention will now be described by way of example with reference to the accompanying drawings in which:-

FIGURE 1 is a perspective view of a unit according to the invention, in the form of a portable cabin,

FIGURE 2 is a plan view partly cut away to show part of the interior of the cabin of Figure 1,

FIGURE 3 is a cross-section to an enlarged scale on the line 3-3 of Figure 2, and

FIGURE 4 is fragmentary longitudinal section, to an enlarged scale, showing the interior of a gas spring shown in Figure 3.

Referring first particularly to Figures 1 and 2 of the drawings, there is shown a unit according to the invention comprising a cabin about 2.3 metres high and 1.2 metres square having side walls 1, a rear wall 2 and a front wall 3 containing a door 4. The wall structure is mounted on a plinth-like base structure 5. The roof 6 of the unit is of a cap-like construction and is a one-piece moulding of plastics material which is sufficiently translucent for natural light to illuminate the interior of the cabin when the door is closed. The cabin is provided with lifting means in the form of eye bolts 7 provided at opposite sides of the base.

The cabin houses a sanitary pan 8 mounted above a floor 9. Flushing of the sanitary pan is effected by operation of an operating means including an operating member comprising a foot pedal 10 to actuate a pump 32 to be described below.

Referring now to Figures 3 and 4 in particular, the plinth-like base structure 5 of the unit is in the form of a water tight box moulded in thermosetting plastics material such as reinforced polyester resin and providing an enclosed chamber or reservoir 11 capable of receiving a suitable chemical liquid which will receive the discharge from the sanitary pan 8 and will also be used to flush the pan. The floor 9 of the unit is provided by an upper polyester resin wall 11a of the reservoir 11 and the foot pedal 10 for operating the pump is mounted for vertical sliding movement as hereinafter to be described.

The pump 32 is provided within a receptacle 20 made as two separate mouldings, in ABS, medium density polyethylene or other suitable plastics material, which are bolted together. The receptacle may be made in any other suitable material such as a suitable steel or of other configuration, if desired.

The receptacle is of generally rectangular box

configuration having a bottom wall 21, opposed side walls 22, 23, and opposed end walls 24, 25. The parts of the side walls 22, 23 provided by the lower moulding are apertured as shown at 20a. The top of the receptacle 20 is closed by a top wall part 26 formed integrally with the upper of the two mouldings which together comprise the receptacle.

The receptacle 20 is received within an opening 27a in the top wall 11a of the reservoir 11 and rests on a base wall 11b of the reservoir 11 so that pumping loads are transmitted to the base wall 11b. The walls of the opening 27a cooperate with an outwardly extending flange 27 of the receptacle 20 and together with self tapping screws connecting the flange 27 to the top wall 11a, serve to hold the receptacle 20 from lateral movement. The receptacle is thereby replacably mounted with a majority thereof within the reservoir and can be quickly and easily removed from the reservoir 11 simply by lifting the receptacle and the pump 32 therein out of the reservoir 11.

The side wall 23 and two opposed end walls 24, 25 of the lower of the moulding which cooperate to provide and receptacle 20 are perforated as shown of 20a whilst the base wall 21 and the other side wall 22 are imperforate. Fixed to the base wall 21 by self-tapping screws, or other fixing means is an outwardly extending flange 30 of a rigid body part 31 of the pump 32. The body part 31 is made as a moulding in a suitable synthetic plastics material such as polyethylene. The pump body part 31 is mounted in the receptacle 20 in engagement with an upstand provided on the base wall 21 thereof. The upstand comprises a part cylindrical wall 33 provided with openings 33a and an inclined part 34 moulded integrally with the remainder of the receptacle 20. A circular diaphragm 35 of PVC, which is provided with a permanent bias away from openings 36 provided in the part 34 is secured to the part 34 by a rivet 34 or by other suitable means. The diaphragm 35 is such that it can be deformed into sealing engagement with the part 34 around the openings 36 by application of pressure to the diaphragm.

The pump body 31 is provided with an outlet opening 38 provided with a ball valve 39 comprising a ball 40 sealingly engagable with a ball seat 41 provided on a ball seat insert 42 made of ABS. The ball 40 is made of medium density polyethylene and is filled with sand to provide the desired mass. The ball 40 is maintained in position by a housing 42 provided with an outlet pipe 43 which is connected to a flush pipe of the sanitary pan 8.

The pump body part 31 is provided with a generally cylindrical portion 50 to which is clamped, by clamping ring 51, a flexible bellows 52 made of plasticised PVC. The bellows 52 is of generally cylindrical configuration having a gen-

erally cylindrical wall 53 of corrugated configuration to provide collapsible bellows and a closed top wall 54 which is trapped between a bottom bellows plate 55 and a top bellows plate 56 which are tightened onto the top wall 54 by four nuts and bolts 57.

The bellows plates 55 and 56 are each provided with a frusto-conical recess 58, 59 respectively to accommodate a housing sleeve 60 fixed to a bearing retaining plate 61 which is secured to the top wall 26 by suitable means such as rivets or screws. The sleeve 60 houses a nylon bearing bush 63 which guides an operating link 64 for vertical sliding movement.

The bellows 52 provides the majority of a variable volume pumping chamber the remainder of which is defined by the pump body part 31.

A flexible operating link cover 65 in the form of a flexible bellows made of plasticised PVC is provided around the operating link 64 and at its lower end is received in a rebate in the plate 61 and is clamped thereby to the top wall 26 and its upper end is secured to the operating member or foot pedal 10.

The operating link 64 is connected at its lower end by welding to a circular flange 66 which is clamped to the bellows plates 55, 56 by the screws 57. At its upper end the operating link 64 has an end closure member 67 from which a threaded spigot 68 extends upwardly and is threadedly received in a bore 78 of the foot pedal 10 so that the connecting link 64 is connected to the pedal 10. A first member 71 of a gas spring 70 has a hemispherical end member 72 disposed in a cup 73 carried by a bracket 74 disposed in an opening 75 of the body part 31 of the pump so that the end member 72 can move laterally within the cup 75 so as to avoid bending forces on the gas spring 70. A second member 69 of the gas spring has a part spherical end member 76 which abuts the underside of the end closure member 67, again avoiding bending forces on the gas spring 70.

The connecting link 64 is of generally cylindrical configuration and is in telescopic sliding relationship with the first member 71 of the gas spring. The first member 71 of the gas spring is in telescopic sliding engagement with the second member 69 thereof. Within the second member 69 the first member 71 is provided with a piston 71a which is in sliding and sealing engagement with the interior of the second member 69. A small amount of oil is provided within the second member 69 to lubricate an 'O' ring which seals the piston 71a, 71b relative to the second member 69 and provide damping to gas flow through a small diameter passage 71c which extends between oppositely facing surfaces of the piston 71a. The interior of the second member 69 is filled with a suitable gas,

such as nitrogen, so that as the second member 69 is moved downwardly by applying pressure to the foot pedal 10 to deform the bellows 53 from an initial condition shown in Figure 3 the gas is forced through the passage 71c in the piston 71a to equalise the pressure on both sides of the piston. The gas is compressed by the reduction in the volume inside the second member 69 on the upper side of the piston 71a due to the volume occupied by the first member 71. When operating pressure is lifted from the foot pedal 10 the pressure of the gas acting on the lower surface SL of the piston 71a, which is of larger area than the annular upper surface Su of the piston 71a creates a differential pressure which forces the piston 71a upwardly to move the second member 71 upwardly to move the bellows 53 back towards the initial condition. The gas passes through the passage 71c in the piston 71a to equalise the pressure on both sides of the piston ready for movement of the second member 69 downwardly again by the application of pressure to the foot pedal 10.

In use, the valve body part 31 and at least a part of the bellows 52 is immersed in a chemical liquid within the reservoir 11. Pressing of the foot pedal 10 by a user with his foot will urge operating link 64 downwardly and hence compress the bellows 53 to cause the diaphragm 34 to close the inlet openings 36 and to lift the ball 40 away from the seat 41 and thus to force the liquid contents of the pump chamber through the feed pipe 43 to flush the sanitary pan 8. The pump mechanism is dimensioned in relation to the usual level of liquid in the reservoir 11 so that one or two operations of the foot pedal 10 will be sufficient to cleanse the pan in normal circumstances. When the user lifts his foot from the pedal the gas spring 70 returns the pedal 10, and hence the bellows 52, to its original position to cause the ball valve 40 to move into sealing engagement with the seat 41 and the diaphragm 34 to move away from the inlet opening 36 so that liquid is drawn into the pump chamber through the openings 36 and entry opening 34.

So as to ensure that only chemical liquid free of solid matter is supplied to the sanitary pan 8 for flushing the latter, the hereinbefore mentioned apertures 20a are provided in the sides 23, 24 and 25 of the receptacle 20 and the receptacle 20 is orientated so that the imperforate side 22 is adjacent to the waste discharge of the sanitary pan 8. As a result liquid delivered via the pump mechanism will be free of solid matter. If desired, an additional screen or screens may be provided externally of the receptacle 20 to divide the reservoir 11 into two regions, one of which contains the receptacle 20 and the other of which contains the outlet of the discharge pipe of the sanitary pan 8.

The reservoir 11 is provided with a means for

emptying the chamber comprising a valve member associated with a discharge tube at the bottom rear of the reservoir 11. The valve mechanism may be of any convenient type and is not illustrated herein.

Similarly the reservoir is provided with an overflow pipe, the inlet end of which is positioned adjacent the top of the chamber and is connected to the hereinbefore mentioned discharge tube at its other end.

The unit incorporates heating means for use in cold weather to prevent freezing of the liquid in the reservoir 11. The heating means takes the form of an immersion heater (not shown) whose head is housed in a compartment connected to the rear wall of the base structure having an exit door, not shown. The heating element of the immersion heater passes through the inner wall of the compartment so as to be immersed in the liquid. The compartment remains sufficiently large to accommodate alternative heating means, such as a calor gas burner or paraffin lamp.

The sanitary pan 8 can be a standard vitreous china flushing pan with bottom outlet which discharges directly through an aperture in the floor 9 of the unit into the reservoir 11. The sanitary pan 8 has a conventional U-bend so as to provide a liquid seal between the flushing pan and the reservoir 11. The unit may be arranged to house further fittings such as a storage tank for the supply of water to a wash basin if fitted and a hand dryer or container for paper towels. If a wash basin is fitted a pump similar but, if desired, of smaller size to the pump hereinbefore described may be provided to pump water from the storage tank to a discharge outlet associated with the sink for hand washing purposes.

The unit may be arranged to house a shower and again a pump similar to that described hereinbefore may be used to pump water from a storage tank to a shower head.

It has been found in practice that it is not necessary to gain access to the gas spring for servicing frequently and if access is necessary it can be relatively easily gained simply by releasing the clamp ring 5. It should be appreciated that the enclosure 20 and pump 32 mounted therein provide a sub-assembly which can be easily and conveniently removed from the reservoir 11.

If desired instead of a water trap provided in the U-bend of a conventional sanitary pan the sanitary pan may be provided with a flap valve operable by the water pumped by the pump.

Although in the illustrated embodiment the top wall 26, of the receptacle effectively closes the top of the receptacle, except for a passage just large enough for the operating link to pass therethrough, if desired the top wall may be of lesser extent and may only comprise the top edge of the side wall of

the receptacle. In this case other means such as the floor of the unit or a separate member may obturate the top of the receptacle, suitable means being provided for guiding the operating link.

It is particularly envisaged that the pump be provided in combination with a container to provide a reservoir for liquid to be pumped. The reservoir and pump combination may be provided to pump sanitary liquid to flush a sanitary pan such as a w.c. or "heads" in a boat or a w.c. in a coach, plane train or the like. In such applications the builder of the boat, train, coach, plane or the like would provide the sanitary pan and all the other fittings required in the relevant part of the boat etc, and a pump and reservoir combination according to the present invention would be connected in position. Alternatively, if desired, the sanitary pan may be supplied in combination with the pump and reservoir combination to provide a self-contained unit to be received by suitable prepared area of the boat etc.

Alternatively, the reservoir may, in use, be connected to a wash basin or shower or the like to supply clean water thereto.

Further alternatively, the reservoir may be divided into two separate reservoirs, one providing liquid for flushing a sanitary pan with one pump according to the first aspect of the invention and the other reservoir containing clean water and a second pump according to the first aspect of the invention to provide water for washing or showering or the like.

Although in the embodiment described the reservoir has been described as being provided as part of the base plinth of the unit if desired the reservoir may be provided as an upstand on the floor of the unit or other area in which the combination is provided.

A pump embodying the present invention has the following advantages:-

by using a gas spring the spring force resisting movement of the pedal is constant throughout the stroke unlike a coil spring arrangement when the spring force would increase as the pedal is depressed; the fixing of the bottom end of the gas spring facilitates guiding of the movement of the foot pedal and results in a more rigid arrangement; there are fewer moving parts, thereby extending the life between services; and servicing is simplified since the pump assembly can be easily removed and replaced simply by removing and replacing the receptacle as described above. All the components are more easily accessible for service and test, there is no need to drain the contents of the chamber in order to service the pump, because the whole of the pump can be removed for servicing and then replaced from the top of the chamber. This avoids loss of fairly expensive sanitary fluid,

which is particularly important when the tank has been recently recharged and little used.

If desired a guiding arrangement for the operating means may be provided without providing a gas spring. For example, a coil compression spring could be provided between the lower bellows plate 59 and the opposed surface of the pump body 31, the recess 59 serving to centre the spring, and instead of telescopically engaging the operating link 64 around the first member of a gas spring it could be telescopically engaged around a guide member fixed at its lower end to a bracket corresponding to the bracket 74.

Further alternatively, if desired the coil spring in this embodiment could be provided within the link cover 65 instead of the pump bellows 52. Further alternatively, even when a gas spring is provided additional coil compression spring means may be provided either within the bellows 52 and/or the link cover 65.

If desired the flexible member which defines a majority of the variable volume pumping chamber may be of other configuration to the generally cylindrical bellows configuration described herein so long as it pumps a sufficient volume of liquid as described hereinbefore.

If desired, instead of the pump comprising a flexible member which defines at least part of the variable volume pumping chamber the pump may comprise two relatively movable rigid member such as a piston movable in a cylinder.

The features disclosed in the foregoing description, or the accompanying drawings, expressed in their specific forms or in terms of a means for performing the disclosed function, or a method or process for attaining the disclosed result, or a class or group of substances or compositions, as appropriate, may, separately or in any combination of such features, be utilised for realising the invention in diverse forms thereof.

Claims

1. A pump comprising a movable member defining at least part of a variable volume pumping chamber, an inlet valve to permit of liquid to enter the chamber thereby and an outlet valve to permit of liquid to leave the chamber thereby, operating means to move the movable member from an initial condition and resilient biasing means to return the movable member towards the initial condition to vary the volume of the pumping chamber to pump liquid into and out of the chamber wherein the resilient biasing means comprises a fluid containing unit in which relative movement of solid elements of the unit occurring on movement of the movable member from the initial condition is di-

rectly resisted by elastic deformation of the fluid and the resultant energy stored in the fluid causes return movement of the solid elements to move the movable member towards the initial condition.

2. A pump according to Claim 1 wherein the movable member comprises a flexible member and the operating member deforms the flexible member from said initial condition and the resilient biasing means moves the flexible member towards the initial condition.

3. A pump according to Claim 1 or Claim 2 wherein the fluid containing unit comprises a piston and cylinder in mutual sliding contact, the piston having opposed surfaces of different operative areas and there being a passageway for restricted flow of fluid between said opposed surfaces of the piston.

4. A pump according to Claim 2 or Claim 3 when dependent on Claim 2 wherein the resilient biasing means comprises first and second telescopically slidable members, a first of said members being fixed to a base part of the pump to which the flexible member is also attached at one end and the operating means and the other end of the flexible member being connected to the second member of the resilient biasing means.

5. A pump according to Claim 4 wherein the flexible member is connected to the second member by an operating link which extends from the flexible member to a position adjacent the upper end of the second member adjacent which the operating link is connected to the operating member and to the second member.

6. A pump comprising a movable member defining at least part of a variable volume pumping chamber, an inlet valve to permit of liquid to enter the chamber thereby and an outlet valve to permit of liquid to leave the chamber thereby and operating means to move the movable member to vary the volume of the pumping chamber to pump liquid into and out of the chamber wherein a guide means is provided to guide the movable member during said deformation.

7. A pump according to Claim 6 wherein the movable member comprises a flexible member and the operating member deforms the flexible member from said initial condition and the resilient biasing means moves the flexible member towards the initial condition.

8. A pump according to Claim 6 or Claim 7 wherein the guide means guides the operating member.

9. A pump according to Claim 8 when dependent on Claim 7 wherein the guide means comprises first and second slidably related members, a first of said members being fixed to a base part of the pump to which the flexible member is also

attached at one end and the operating means and the other end of the flexible member being connected to the second member.

10. A pump according to Claim 9 wherein the flexible member is connected to the second member by an operating link which extends from the flexible member to a position adjacent the upper end of the second member adjacent which the operating link is connected to the operating member and to the second member.

11. A pump according to any one of the preceding claims wherein the pumping chamber is disposed within a receptacle, the receptacle including a wall through which the operating means passes so that an operating member is disposed externally of the receptacle and the pumping chamber internally of the receptacle, and the receptacle is adapted to be positioned at least partly within a reservoir for liquid to be pumped and the receptacle is adapted to permit passage of liquid to the interior thereof from such reservoir.

12. A pump according to any one of the preceding claims wherein the pump is operatively connected to a sanitary pan to flush the pan with liquid withdrawn from a region of a reservoir which is separated by a filter screen from another region thereof into which the sanitary pan discharges.

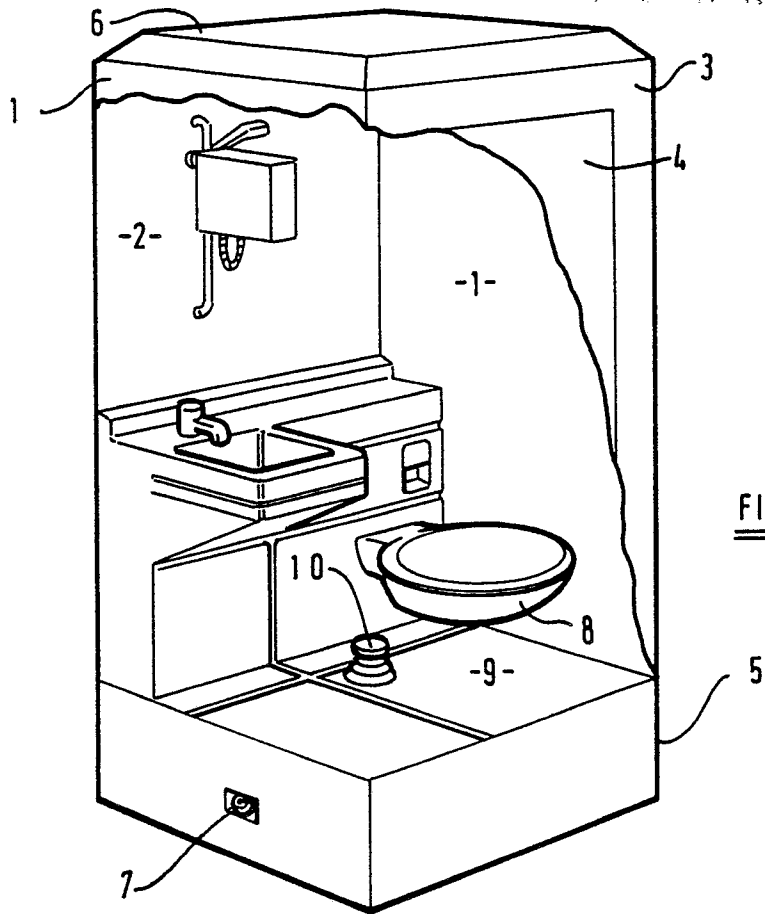

FIG 1

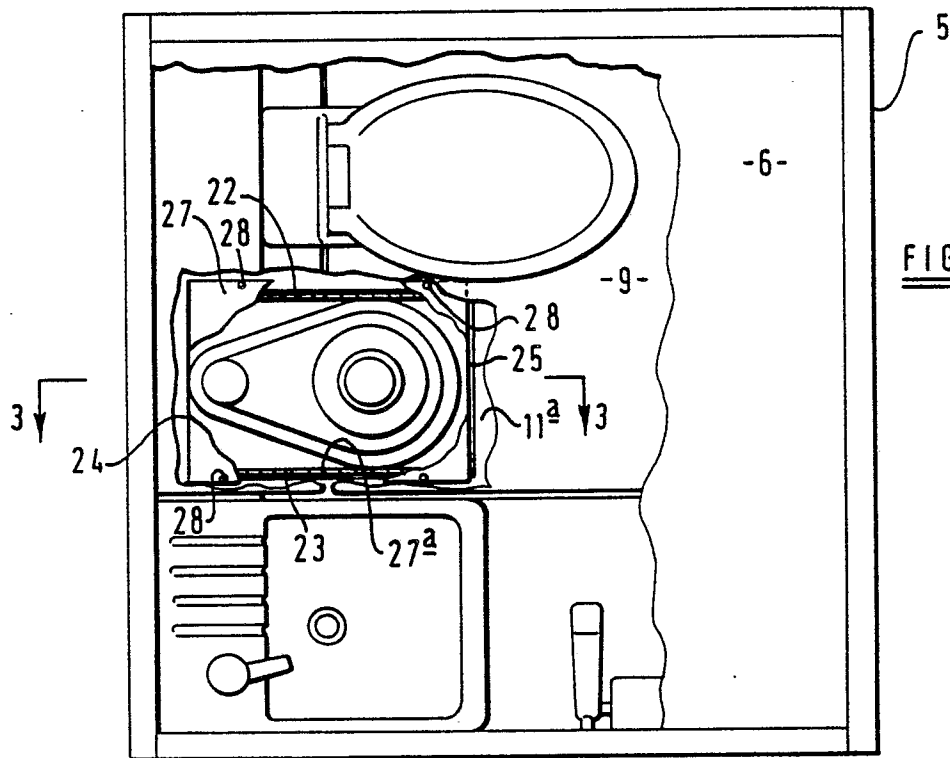
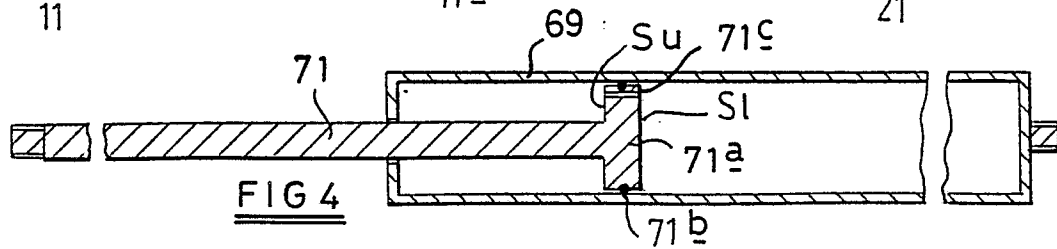
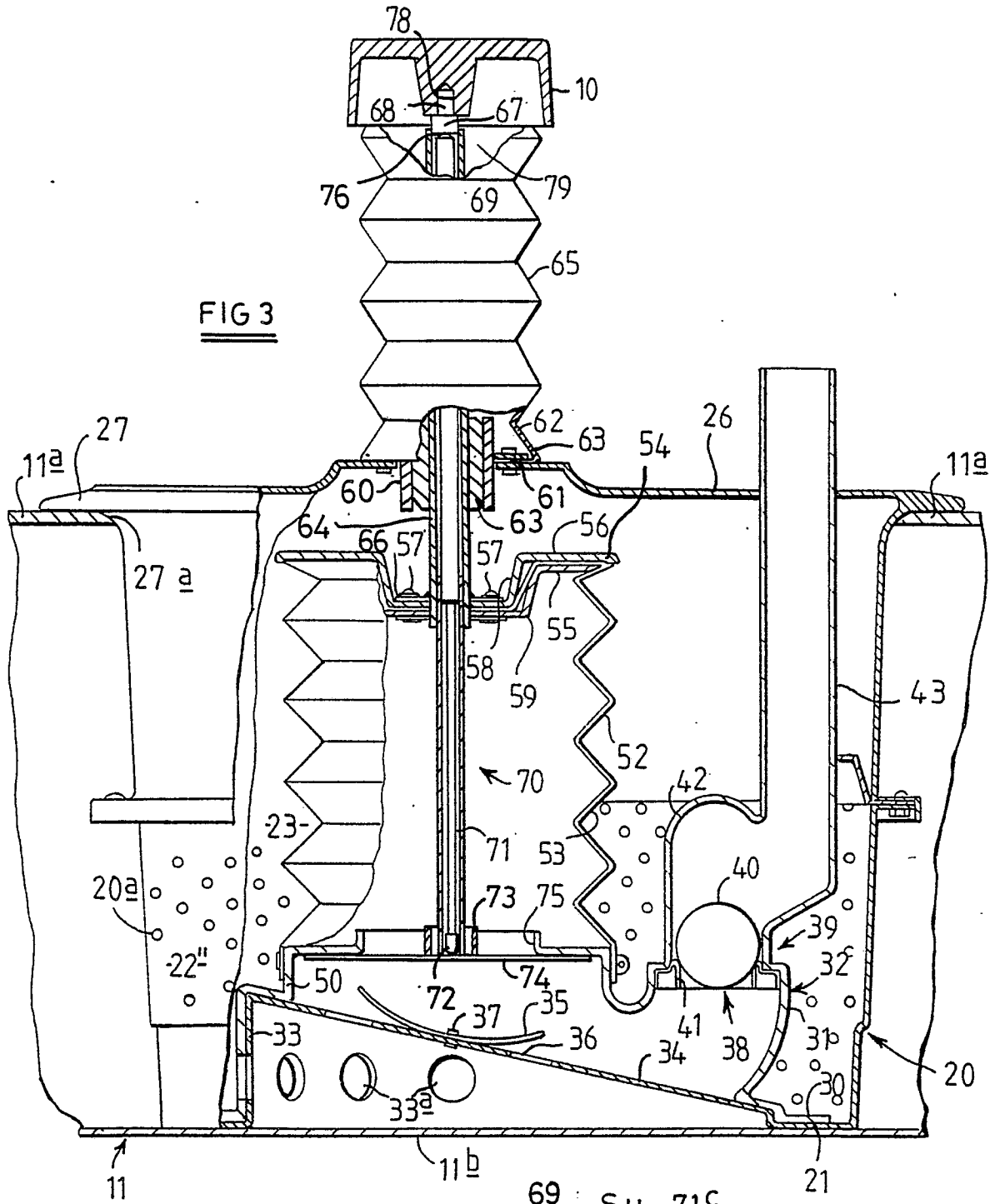

FIG 2





DOCUMENTS CONSIDERED TO BE RELEVANT			EP 88305837.2
Category	Citation of document with indication, where appropriate, of relevant passages	Relevant to claim	CLASSIFICATION OF THE APPLICATION (Int. Cl.4)
A	<u>GB - A - 1 395 118</u> (MANSFIELD) * Page 1; page 2, lines 52-61; claims 1,2; fig. 10,11 * --	1,5-7, 9,10	E 03 D 5/012 F 04 B 9/14
A	<u>DE - A1 - 3 101 935</u> (GARTHE-WOLFF GMBH & CO.) * Pages 1-2; fig. 3 * --	1,6,7	
A	<u>GB - A - 939 529</u> (KIGASS) * Totality * --	1,2,4-7	
A	<u>GB - A - 4 941/A.D. 1915</u> (LEMAN) * Totality * --	1	
A	<u>US - A - 2 943 577</u> (BARKER) * Totality * --	1,3	TECHNICAL FIELDS SEARCHED (Int. Cl.4)
A	<u>US - A - 3 180 566</u> (MURAT) * Totality * --	1,5,6, 10	E 03 D F 04 B E 03 C B 67 D
A	<u>EP - A2 - 0 194 417</u> (MEGAPRODUCT) * Page 17; fig. 1 * ----	1,6,10	
The present search report has been drawn up for all claims			
Place of search VIENNA		Date of completion of the search 05-10-1988	Examiner LANG
<p>CATEGORY OF CITED DOCUMENTS</p> <p>X : particularly relevant if taken alone Y : particularly relevant if combined with another document of the same category A : technological background O : non-written disclosure P : intermediate document</p> <p>T : theory or principle underlying the invention E : earlier patent document, but published on, or after the filing date D : document cited in the application L : document cited for other reasons & : member of the same patent family, corresponding document</p>			