

**EUROPEAN PATENT APPLICATION**

Application number: **88201531.6**

Int. Cl.4: **F24C 15/20**

Date of filing: **15.07.88**

Priority: **27.07.87 IT 2145287**

Date of publication of application:  
**01.02.89 Bulletin 89/05**

Designated Contracting States:  
**DE FR GB IT**

Applicant: **ELICA S.p.A.**  
**Via Dante 288**  
**Fabriano (Ancona)(IT)**

Inventor: **Urbani, Urbano**  
**Via Buozi**  
**Chiaravalle (Ancona)(IT)**

Representative: **Raimondi, Alfredo, Dott. Ing.**  
**Prof. et al**  
**Studio Tecnico Consulenza Brevetti Piazzale**  
**Cadorna 15**  
**I-20123 Milano(IT)**

**Suction hood for fumes, especially for domestic kitchens, with large collection area.**

The suction hood for fumes, especially for domestic kitchens, according to this invention possesses a centrifugal rotor with vertical axis, closed at the bottom, keyed to the shaft of a motor supported with its axis vertical inside a suction opening present in the upwardly facing wall of a spiral guide shell of increasing cross-section, leading to a discharge duct and/or a recirculation grill, which guide shell possesses a closed bottom wall, situated above the bottom wall, having apertures and facing the collection area of the hood of an external casing, which encloses and supports the guide shell, and defines, above the guide shell itself, a zone communicating with its suction opening, there being also present a discharge duct equipped with sound absorption means.

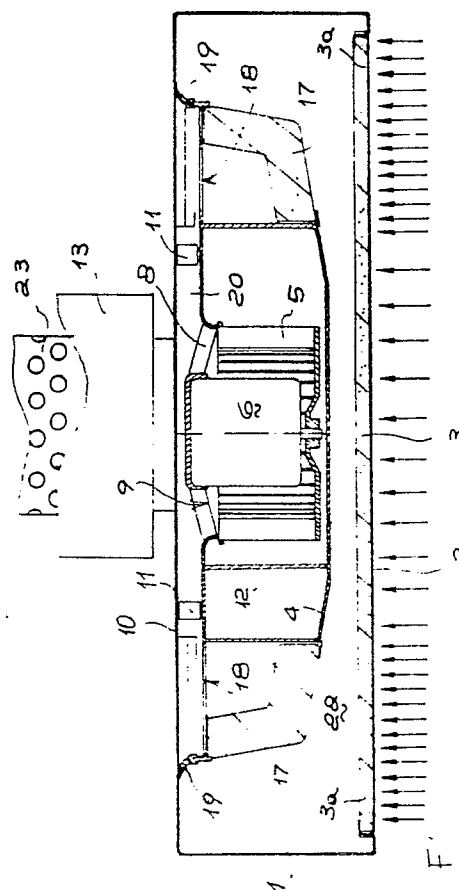

**EP 0 301 640 A1**

### Suction hood for fumes, especially for domestic kitchens, with large collection area.

The subject of the present invention is a suction hood for fumes, especially for domestic kitchens.

In kitchens, especially in domestic kitchens, vapours are generated during the cooking of food, which vapours frequently carry with them greasy and aromatic substances, arising from the foods that have been raised to high temperature.

Such entrained substances in the ambient air are undesirable, both on account of the humidity content brought into the room and on account of the odours existing in it.

Devices are therefore used for collecting said emissions, hereinafter termed for short "fumes", which for domestic kitchens are usually composed of a hood mounted above the cookers or stoves from which the fumes are emitted, the hood being equipped with an electrical extraction fan and conducting the sucked air, containing the fumes, to a duct for discharging the fumes to the outdoors, or leading to a recirculation opening for feeding the sucked air back into the room, in this second case means being provided for filtering the fumes contained in the recycled air.

In both the solutions, that is to say for hoods discharging outdoors and for recirculation hoods, there is present on the collecting opening of the hood a filtering mattress, adapted for retaining the extracted particles of larger dimensions, in the form of dust, humidity, drops of fat and the like, in this way protecting the extraction fan from deposition of such impurities.

In the known hoods, the extraction fan is composed of a centrifugal fan, with its suction opening facing towards the collection opening of the hood, which fan is connected by its discharge opening to the one or the other outlet of the hood itself.

This constructional solution, nevertheless, does not allow benefit to be obtained of the entire extent of the collection opening of the hood, because the greater part of the sucked air flow affects an area of the collection opening not much larger than the diameter of the suction opening of the fan, while the remaining part of this opening, and of the associated filtering mattress, is affected only to a slight extent by the flow.

This involves two classes of disadvantages: in the first place, there is the utilization of a restricted area of the filter mattress, through which therefore there is a flow at high speed and relatively high pressure loss, causing moreover a more rapid clogging of the filter mattress itself, and a reduced life of the filter, furthermore offering a reduced area to the other filtration devices; secondly, the localized suction in a limited area close to the centre of the

collection opening gives rise to a distribution of the sucked flow from the cookers substantially in a conical volume, with its apex in the suction opening of the fan of the hood, and an appreciable velocity of the sucked air in the vicinity of the axis of the cone, and a fairly reduced flow at its periphery.

This means that there is good extraction of the fumes only in the central zone of the cookers, whereas the fumes generated at their periphery escape easily from the air flow sucked in said zone, which has a low velocity, and diffuse into the surrounding air.

In order to achieve, nevertheless, a satisfactory suction, it is then necessary to use a larger suction power, with consequent greater expenditure, and furthermore with considerable noise deriving also, in the conventional solutions, from the direct connection of the fan to the walls of the external casing of the hood, it being difficult to construct with such a configuration, for reasons of bulk, sound absorption devices or devices for damping the vibrations.

The problem therefore arises of providing a hood, which shall enable an optimum distribution of the suction flows over the entire desired collection area to be achieved, preventing the fumes from escaping into the surrounding air, and furthermore assuring especially silent operation.

Said results are achieved by the present invention, which provides a suction hood for fumes, especially for domestic kitchens, which possesses a centrifugal rotor having a vertical axis, closed at the bottom, keyed to the shaft of a motor supported with its axis vertical inside a suction opening present in the upwardly facing wall of a spiral guide shell of increasing cross-section, leading to a discharge duct and/or to a recirculation grating, which guide shell possesses a closed bottom wall, situated above the bottom wall, having openings and facing the collection area of the hood of an external casing which encloses and supports the guide shell, and defines, above the guide shell itself, a zone communicating with its suction opening, there being also present a discharge duct equipped with sound absorption means.

The guide shell is supported inside the external casing by antivibration supports.

The zone of the external casing communicating with the suction opening of the guide shell is separated from the remaining part of the internal volume of the casing, communicating with its bottom wall having apertures, there being present access apertures to the zone communicating with the suction opening of the guide shell.

The access apertures to the zone communicating with the suction opening of the guide shell are

situated near the lateral walls of the guide shell, extending substantially throughout the entire length of the lateral walls themselves, said access apertures to the suction opening of the guide shell being substantially opposite the corresponding lateral zones of the bottom wall, having apertures, of the external casing.

The access apertures to the zone communicating with the suction opening of the guide shell may be equipped with replaceable carbon filter elements, sealing gaskets being provided which occlude the passage outside the carbon filter elements.

The bottom wall, having apertures, of the external casing is formed as a grating and is equipped, over its entire extent, with a filter mattress, adapted for retaining liquid or solid particles entrained by the sucked air, with limited loss of head, said filter mattress being traversed in a substantially uniform manner by the sucked air over its entire area.

The discharge duct is equipped with a perforated inner wall and a closed outer wall, defining an annular volume containing sound-absorbing foam material, and extends through a distance at the outlet of the guide shell, being then connected to a duct leading the sucked air outdoors.

Further details will become apparent from the following description, given with reference to the attached drawings, in which there are shown: in figure 1, the hood according to this invention, in section on the plane I-I of figure 3; in figure 2, a section on the plane II-II of figure 3; in figure 3, a section on the plane III-III of figure 2.

As the figures show, the hood according to this invention is composed of an external casing 1, equipped at the bottom with a grating 2 and a filter mattress 3, extending over the entire collection area of the hood, inside which casing there is a suction unit, comprising a spiral guide shell 4 and a centrifugal rotor 5, closed at the bottom and open at the top, keyed to the shaft of an electric motor 6, with vertical axis, the motor being disposed inside the rotor and supported in its upper part by means of a connector 7 suspended from radial spokes 8 at the centre of the upper circular aperture 9 of the guide shell 4.

The guide shell 4 is supported inside the casing 1 at its upper wall 10 by means of antivibration supports 11 and possesses a spiral lateral wall 12, leading to a vertical discharge duct 13 in the rear part of the casing 1 and to a front recycling grating 14.

A deflector 15, rotatable on an axis 16, closes depending upon its position the passage to the tube 13, as shown in full line in figure 3, or the passage to the grating 14, as indicated in broken lines.

In its lateral zones, the guide shell 4 has the

seatings for mounting the carbon filter blocks 17, which face the apertures 18, bounded by sealing gaskets 19, which apertures communicate with the space 20 contained between the upper wall 21 of the guide shell 4 and the upper wall 10 of the external casing 1.

In the case where a hood which supplies the extracted fumes solely to the discharge duct 13 is desired, the filter blocks 17 may be omitted.

Rotation of the rotor 5 causes a flow of air, which generates a suction inside the space 20 and in the lower zone 22 of the casing 1, thereby causing a suction of air through the filter mattress 3, adapted for retaining liquid or solid particules entrained by the extracted air and, if they are present, also through the filter blocks 17, adapted for retaining the odours of the fumes, and thus causing an expulsion of the extracted air through the grating 14 or the duct 13.

Since the entry of the extracted air into the zone 20 takes place through the apertures 18, that is to say at the periphery of the guide shell 4, the flow of air drawn in from outside affects in a substantially uniform manner the entire area of the filter mattress 3, with a slight predominance for its lateral zones 3a, as shown by the arrows F in figure 1, the density of which is greater in the zones of higher suction velocity.

This, in contrast with the conventional suction hoods, in which the suction was predominantly in the central zone, guarantees, on the one hand improved utilization of the area of the mattress 3, which is traversed in a more uniform manner by the air flow over its entire area, thereby obtaining, for a given capacity, lower flow velocities and reduced losses of head, and on the other hand assures a more efficient suction of the fumes situated beneath the hood, even through they may be localized near the peripheral zone of the collection area, as a result also of the slight increase in the velocity of the flow of the air sucked in at the lateral zones of the hood, facing the apertures 18.

The structure according to this invention also allows the entire guide shell 4 and the motor attached to it to be supported by means of antivibration bearings 11, thereby substantially reducing the operating noise of the extraction hood.

The hood according to this invention also enables carbon filter blocks 17 of large dimensions to be used, thereby obtaining a smaller loss of pressure of the air passing through them and a longer life of the filters.

The quietness of operation of the hood is ensured, in addition to what has been described above, also by the arrangement of the discharge duct 13, which has a perforated inner wall 23, connected to the outlet opening 24 of the guide shell 4, and a coaxial, outer wall 25, with a filling in

the annular space between the two walls 23, 25 of an expanded material 26, having sound-absorbing properties.

The duct 13, constructed in this manner, extends vertically through the height available in the item of furniture in which the hood is mounted, for example through a height h of some tens of centimetres, and constitutes the support and fixing base for the conventional duct leading the extracted fumes out of doors, not shown in the figure.

Numerous variants may be introduced, without thereby departing from the scope of the invention, in its general characteristics.

### Claims

1. Suction hood for fumes, especially for domestic kitchens, characterized by the fact that it possesses a centrifugal rotor having a vertical axis, closed at the bottom, the rotor being keyed to the shaft of a motor supported with its axis vertical inside a suction opening present in the upwardly facing wall of a spiral guide shell of increasing cross-section, leading to a discharge duct and/or to a recirculation grating, which guide shell possesses a closed bottom wall, mounted above the bottom wall, having apertures, and facing the collection area of the hood of an external casing which encloses and supports the guide shell and defines, above the guide shell itself, a zone communicating with its suction opening, there being also present a discharge duct equipped with sound absorption means.

2. Suction hood for fumes, especially for domestic kitchens, according to claim 1, characterized by the fact that the guide shell is supported inside the external casing by antivibration supports.

3. Suction hood for fumes, especially for domestic kitchens, according to claim 1, characterized by the fact that the zone of the external casing communicating with the suction opening of the guide shell is separated from the remaining part of the internal volume of the casing, communicating with its lower wall having apertures, there being present access apertures to the zone communicating with the suction opening of the guide shell.

4. Suction hood for fumes, especially for domestic kitchens, according to claim 3, characterized by the fact that the access apertures to the zone communicating with the suction opening of the guide shell are situated near the lateral walls of the guide shell, extending substantially through the entire length of the lateral walls themselves, said access apertures to the suction opening of the guide shell being substantially opposite the corresponding lateral zones of the bottom wall, having apertures, of the external casing.

5. Suction hood for fumes, especially for domestic kitchens, according to claim 3, characterized by the fact that the access apertures to the zone communicating with the suction opening of the guide shell are equipped with replaceable carbon filter elements, sealing gaskets being present which occlude the passage outside the carbon filter elements.

6. Suction hood for fumes, especially for domestic kitchens, according to claim 1, characterized by the fact that the bottom wall, having apertures, of the external casing is constructed as a grating and is equipped, over its entire extent, with a filter mattress, adapted for retaining liquid or solid particles entrained by the extracted air, with a limited loss of pressure, said mattress being traversed in a substantially uniform manner by the extracted air over its entire area.

7. Suction hood for fumes, especially for domestic kitchens, according to claim 1, characterized by the fact that the discharge duct is equipped with a perforated inner wall and a closed outer wall, defining an annular space containing a sound-absorbing expanded or foam material, and extends for a distance at the outlet from the guide shell, being then connected to a duct leading the extracted air to the outdoors.

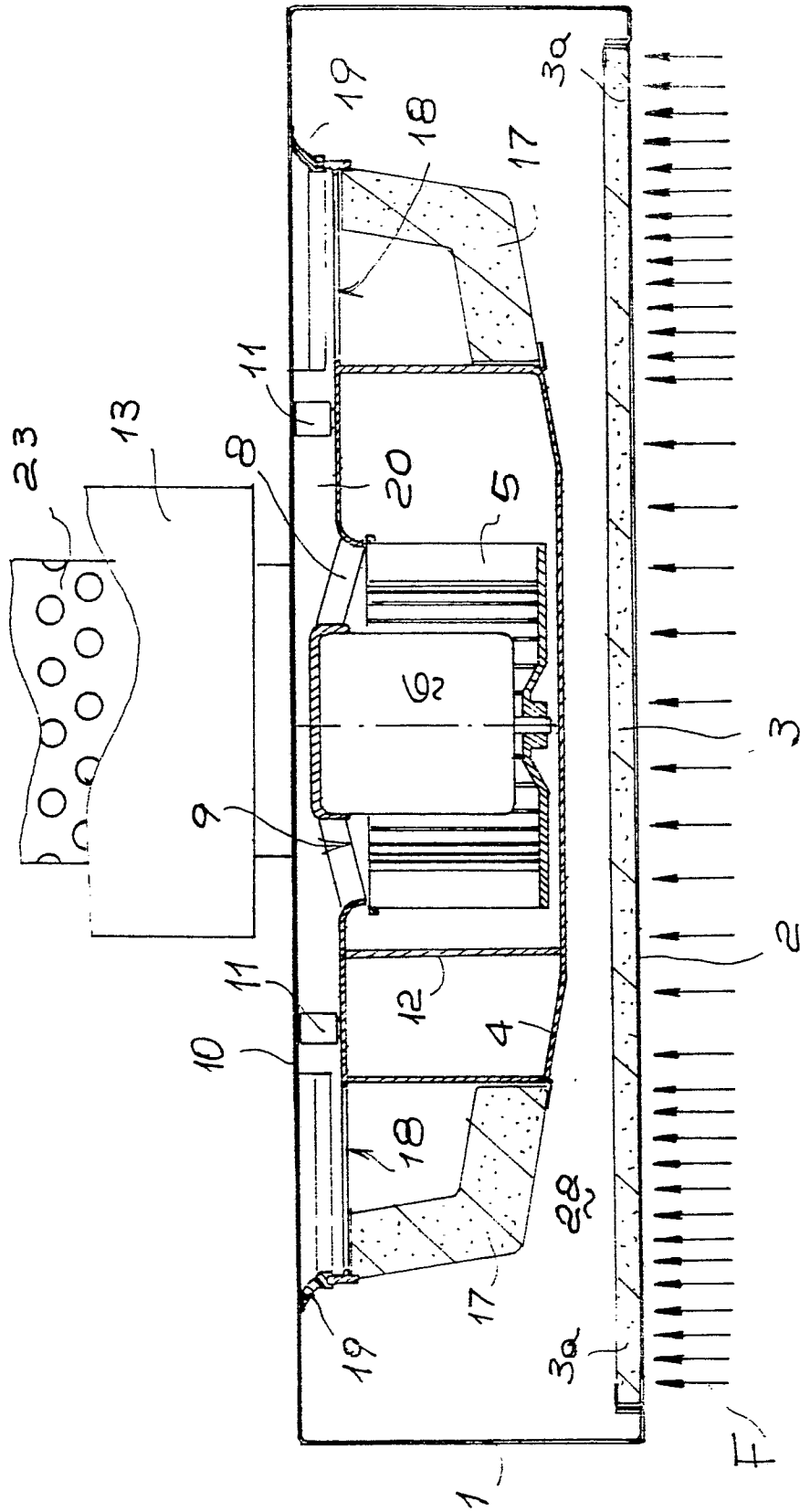

Fig. 1

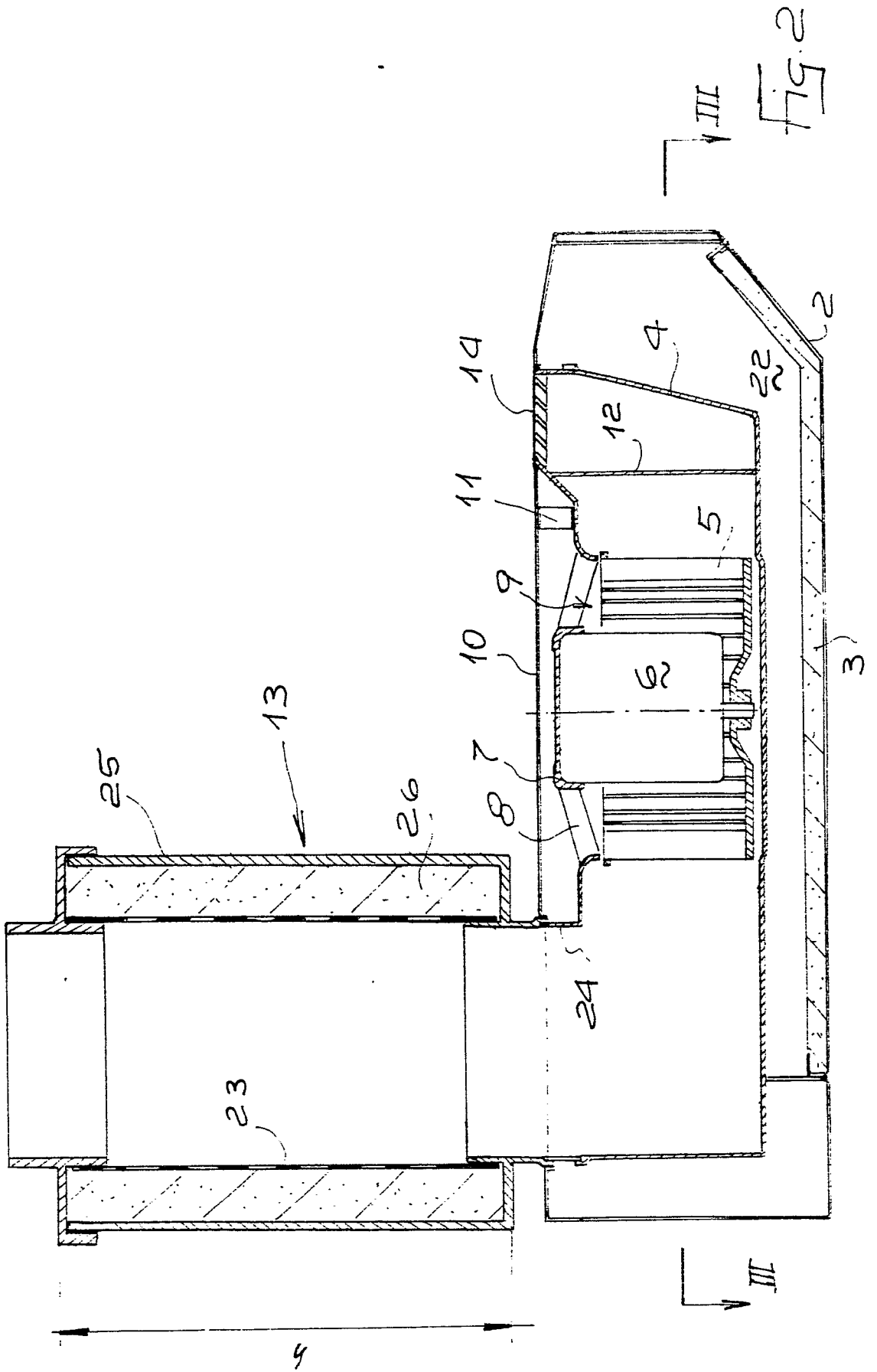

FIG. 2

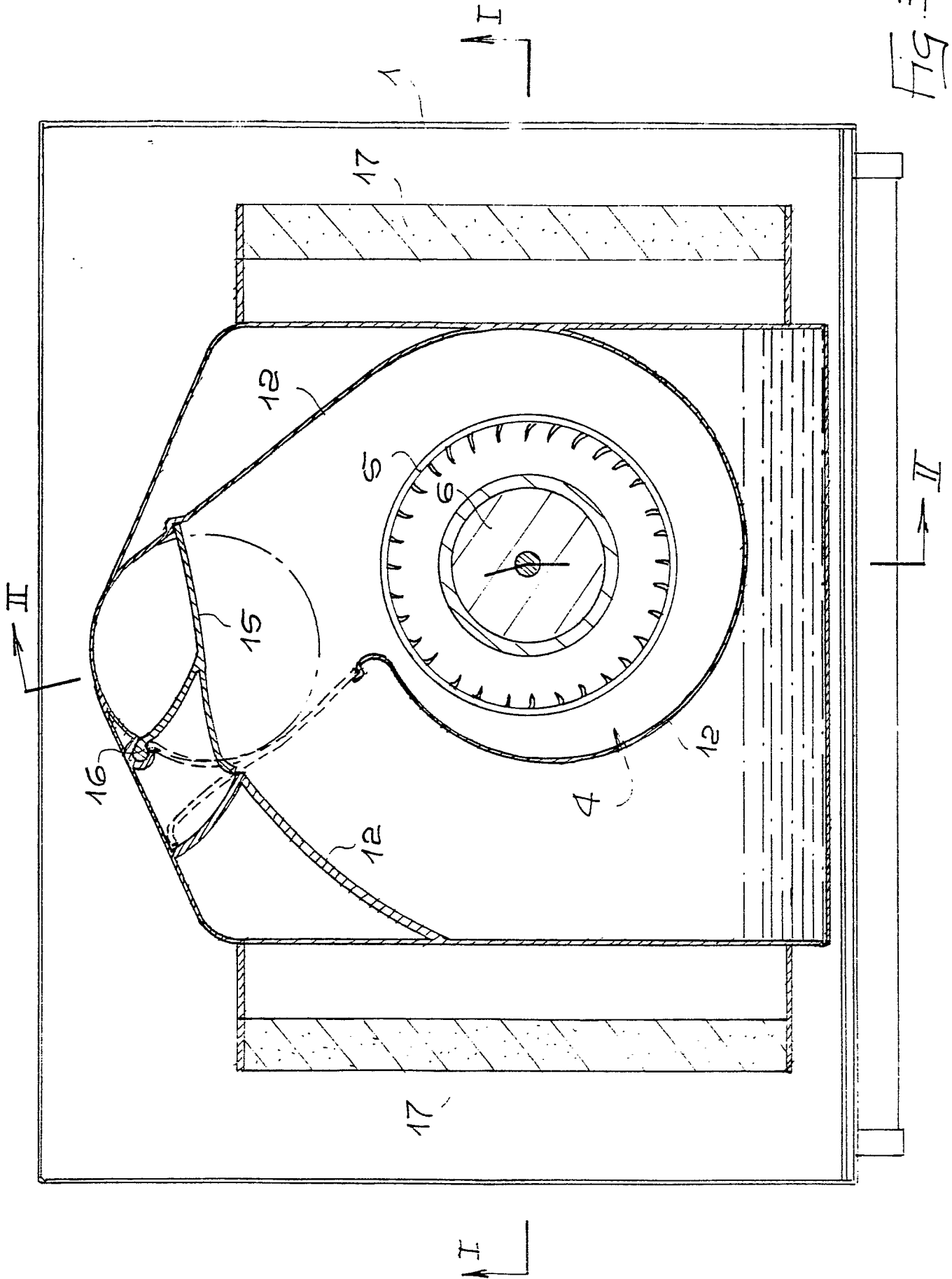

FIG. 3



DOCUMENTS CONSIDERED TO BE RELEVANT			
Category	Citation of document with indication, where appropriate, of relevant passages	Relevant to claim	CLASSIFICATION OF THE APPLICATION (Int. Cl.4)
A	FR-A-1 290 517 (ELM WORKS) * Page 3, left-hand column, paragraph 4; page 3, right-hand column; abstract, points 1-5; figures 1-4 *	1,2	F 24 C 15/20
A	FR-A-2 077 027 (BERGMARK) * Page 6, lines 1-16; figures *	1	
A	FR-A-2 346 643 (BOSCH-SIEMENS HAUSGERATE GmbH) * Page 5, lines 1-11; figure 1 *	1	
A	DE-U-6 900 973 (GAGGENAU) * Abstract *	1	
			TECHNICAL FIELDS SEARCHED (Int. Cl.4)
			F 24 C
The present search report has been drawn up for all claims			
Place of search	Date of completion of the search	Examiner	
THE HAGUE	21-10-1988	VANHEUSDEN J.	
CATEGORY OF CITED DOCUMENTS		T : theory or principle underlying the invention	
X : particularly relevant if taken alone		E : earlier patent document, but published on, or after the filing date	
Y : particularly relevant if combined with another document of the same category		D : document cited in the application	
A : technological background		L : document cited for other reasons	
O : non-written disclosure		.....	
P : intermediate document		& : member of the same patent family, corresponding document	