

12

**EUROPEAN PATENT APPLICATION**

21 Application number: **88850286.1**

51 Int. Cl.4: **D 21 F 11/04**

22 Date of filing: **31.08.88**

30 Priority: **16.10.87 SE 8704040**

43 Date of publication of application:  
**19.04.89 Bulletin 89/16**

84 Designated Contracting States:  
**AT BE DE ES FR GB IT NL SE**

71 Applicant: **SCA DEVELOPMENT AKTIEBOLAG**  
**S-851 88 Sundsvall (SE)**

72 Inventor: **De Ruvo, Alf**  
**Tullgatan, 19**  
**S-853 33 Sundsvall (SE)**

**Terland, Ole**  
**Parkgatan 27**  
**S-852 38 Sundsvall (SE)**

74 Representative: **Illum, Leif-Otto**  
**Svenska Cellulosa Aktiebolaget SCA Kungsgatan 33**  
**S-111 56 Stockholm (SE)**

54 **Method of making three-layer paper.**

57 The invention relates to a method of making a symmetrical three-layer paper of two heterogeneous stocks, one of which forms the top layers of the paper, and the other one forms the intermediate layer thereof. According to the invention, the top layer and substantially half the grammage of the intermediate layer are formed by co-forming in two separate head boxes, whereafter the two separately formed layers are combined at a dry solids content not exceeding 12%.

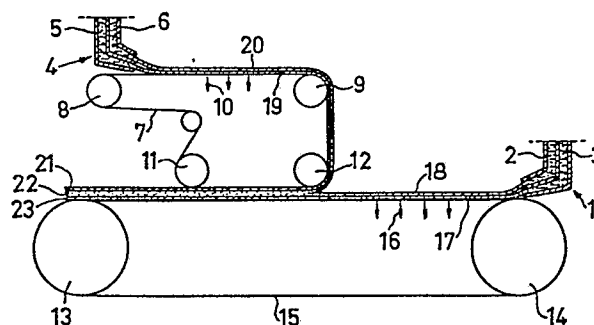

## Description

## Method of making three-layer paper

This invention relates to a method of making a symmetrical three-layer paper, more precisely a paper made of two heterogeneous stocks, preferably in that one stock forms the top layers of the paper and the other stock forms the intermediate layer thereof.

It is known since long to make paper of several layers, especially at the manufacture of cardboard and kraft liner, i.e. for products having a grammage exceeding 100 g/m<sup>2</sup>. In most cases this is carried out in such a way, that the layers are formed separately and at a sufficient dry solids content are pressed together to bring about a multi-layer structure, so-called separate forming. The advantages of this manufacturing method are

- good control of the fibre distribution in the different layers
- good possibilities of preventing admixture of fibres in the different layers
- great possibilities of varying the grammage range by the number of layers and grammage/layer.

The disadvantages are

- difficulty of maintaining the internal bond strength at more than two layers
- higher capital costs.

Another method of making multi-layer paper is the so-called co-forming. This takes place in stratified head boxes, which implies that different stocks are ejected simultaneously through separate nozzles and form a combined jet out of the head box. Hereby, however, a considerable mixture of fibres between the layers can be obtained, and there are no possibilities of separating the white water. This method does not yield advantages as great as the separate forming in respect of fibre control and grammage flexibility, but the capital costs are lower, and the decrease in internal bond strength at more than two layers is less great.

It is, thus, previously known to use multi-layer head boxes where all layers are formed simultaneously.

One method of making multi-layer paper is described in WO 85/05387.

The Figure in said specification shows an arrangement for the manufacture of a three-layer paper, comprising an inner wire 1 and an outer wire 4. From a head box 9 stock is ejected on the wire 1 and dewatered, whereafter stock from another box 10 is ejected on the web, and additional dewatering is carried out by means of a roll 2, and the two layers are passed between the inner and the outer wire.

The second surface layer is formed of pulp suspension from a third head box 14 on a wire 8 and combined with the two other layers at the turning roll 7.

According to the invention, however, the two top layers and substantially half the intermediate layer shall be formed by co-forming from two separate head boxes, and the two layers then are combined by separate forming.

The method according to the invention is especially suitable for use at the manufacture of high-quality

fine paper, especially suitable for copying in xerography.

5 According to the invention, only two separately formed layers are required for bringing about a three-layer structure.

10 At the method according to the invention, a top side is pressed against a top side, which yields good symmetry and a better internal bond strength than at co-forming where dewatering occurs in both directions.

15 The invention also renders it possible to permit high hydrodynamic flows, because the number of layers in a box is restricted to two, and the dewatering distance can be adjusted to the dewatering demand. It is hereby possible to use low concentrations in the intermediate layer, and a high proportion of short fibres, possibly with high beating degree, in the outer layer in order to obtain a good surface. The low concentration makes it possible to form a paper with good appearance and long fibres (softwood). The invention, therefore, can combine multi-layer technique with increasing possibilities of using long fibres. At present at least 50% hardwood is used in fine paper. By using the above technique it shall be possible to freely choose the proportions of long fibres and short fibres in the intermediate layer and thereby reduce substantially the dependence on wood at the making of a fully satisfactory fine paper.

20 By applying a separate forming technique, the bending stiffness can come close to the theoretical level of a layer structure. This implies an improvement of about 20% of the bending stiffness at a fibre mixture of 50% birch fibre and 50% long fibre. The high-beaten short fibre on the surface yields a high smoothness, which reduces the demand of glazing. In the intermediate layer filling agent can be applied to reduce the risk of sediments and wear from the paper surface.

25 By joining two identically formed layers, so that the wire sides constitute outer sides, a sheet is obtained which has perfect symmetry, which is considerably better than the one obtained if the sheet had been formed in a single step. This is due to the fact, that the flow forces during draining tend to distribute the fine material obliquely in the transverse direction of the sheet. There is more fine material on the surface than toward the wire, where the flow has been strongest. A sheet formed in a single step, therefore, always shows a greater or smaller difference in the properties in the transverse direction of the sheet. The only way of making an entirely symmetrical sheet, therefore, is to join two identically formed layers with the top sides or wire sides against each other. The wire sides are unsuitable, because the lack of fine fibres results in a low internal bond strength. The invention makes use of these facts so as to make a sheet with highest possible symmetry, which sheet, therefore, has extreme dimension stability. Since this is a requirement on a paper capable to be used in a copying machine, this implies that a paper manufactured according to the

invention is extremely suitable for use as copying paper.

Conclusively, the method according to the invention yields a paper with

- higher bending stiffness
- higher symmetry
- free choice of fibre mixtures

possibility of high filling agent proportion.

According to a special embodiment of the method according to the invention, the intermediate layer is formed at low head box concentration, and the outer layer is formed at a higher one.

The invention is described in the following by way of an embodiment thereof and with reference to the accompanying drawing.

#### EXAMPLE

The Figure shows a wire 15 running over the breast rolls 13,14. From a head box 1 with layers 2 and 3 the stock for one top layer is passed through 3 and half the grammage for the intermediate layer through 2 in order to form the co-formed web 18 on the wire. Dewatering takes place at 16. From the head box 4, which also comprises two layers 5 and 6, the stock is passed in the same way for the top layer through 5 and about half the grammage for the intermediate layer through 6. The resulting web 20 is dewatered at 10 through the wire 19. The wire with the web 20 then runs over the roll 9 and is separately formed with the web 18 at the press roll 12. The complete three-layer paper then consists of the top layers 21 and 23 and the intermediate layer 22.

The invention is not restricted to the embodiment shown and described, but can be varied within the scope of the invention idea.

#### Claims

1. A method of making a symmetrical three-layer paper of two heterogeneous stocks, one of which forms the top layers of the paper, and the other stock forms the intermediate layer of the paper, **characterized in** that the top layers and substantially half the grammage for the intermediate layer are formed by co-forming in two separate head boxes, and that the two separately formed layers are combined at a dry solids content not exceeding 12%.

2. A method as defined in claim 1, **characterized in** that the intermediate layer is formed at a low head box concentration of 0,1-1,0%, and the outer layer at a higher concentration of 0,3-1,2%.

3. A method as defined in claim 1, **characterized in** that the top layers in the respective co-formed layers are pressed against each other at the subsequent separate forming.

4. A method as defined in claim 1, **characterized in** that the stock for forming the outer layer contains a proportion of short fibres of 80-100%, possibly with high beating degree, and the intermediate layer a proportion of long

fibres of 70-100%.

5. A method as defined in claim 1, **characterized in** that to the stock for forming the intermediate layer a filling agent in an amount of at least 10% is added.

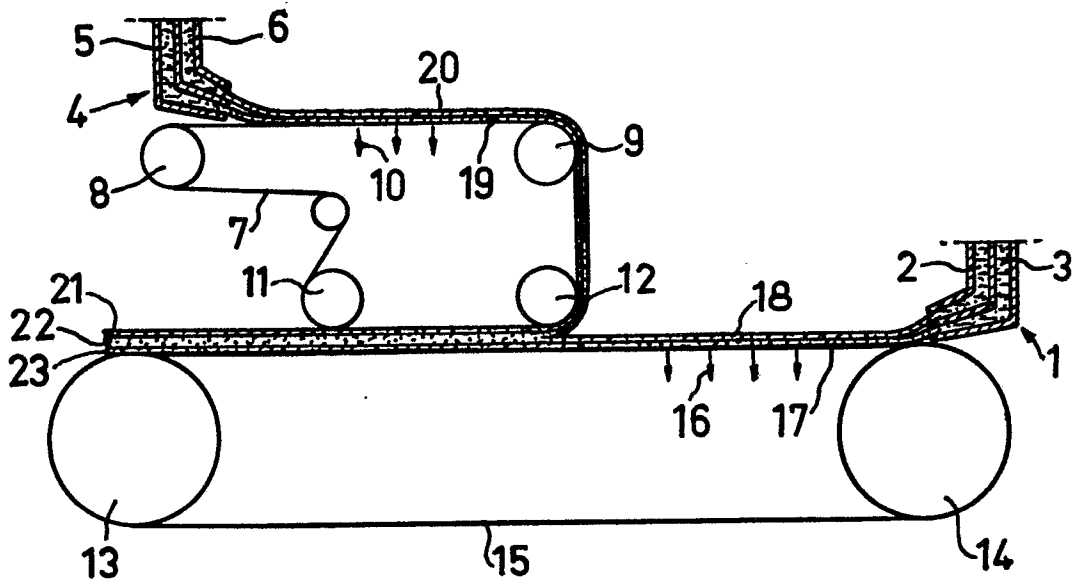



DOCUMENTS CONSIDERED TO BE RELEVANT			
Category	Citation of document with indication, where appropriate, of relevant passages	Relevant to claim	CLASSIFICATION OF THE APPLICATION (Int. Cl. <sup>3</sup> )
A	WO-A- 85/05 387 (A AHLSTROM CORPORATION)	1	D 21 F 11/04
			TECHNICAL FIELDS SEARCHED (Int. Cl. <sup>3</sup> )
			D 21 F
The present search report has been drawn up for all claims			
Place of search	Date of completion of the search	Examiner	
STOCKHOLM	20-12-1988	JENSÉN O.	
<b>CATEGORY OF CITED DOCUMENTS</b> X : particularly relevant if taken alone Y : particularly relevant if combined with another document of the same category A : technological background O : non-written disclosure P : intermediate document T : theory or principle underlying the invention E : earlier patent document, but published on, or after the filing date D : document cited in the application L : document cited for other reasons & : member of the same patent family, corresponding document			