





EUROPEAN PATENT APPLICATION

 Application number: **88309443.5**



 Int. Cl.4: **B41J 31/16 , B41J 32/02**

 Date of filing: **10.10.88**



 Priority: **20.10.87 IT 6787287**

 Date of publication of application:
26.04.89 Bulletin 89/17



 Designated Contracting States:
AT BE CH DE ES FR GB LI NL

 Applicant: **Ing. C. Olivetti & C., S.p.A.**
Via G. Jervis 77
I-10015 Ivrea (Turin)(IT)

 Inventor: **Solero, Giorgio**
Via Botticelli 11/12
I-10155 Torino(IT)
 Inventor: **Ferrara, Giuseppe**
Via Bengasi 3
I-10042 Nichelino (TO)(IT)

 Representative: **Pears, David Ashley et al**
REDDIE & GROSE 16 Theobalds Road
London WC1X 8PL(GB)

Cartridge for an inked ribbon with a re-inking device.

 A re-inking device (11) is applied to a cartridge (12) of the type comprising a container (13) having a magazine (34) for accommodating an inked ribbon (32) of the closed loop type disposed in loosely arranged turns, and a pair of toothed rollers (43) for unidirectional feed of the ribbon (32). The re-inking device (11) comprise an ink reservoir (51) which is housed in a closed casing (53) fixed removably in the interior of the container (13), and an ink metering means (52) having an internal portion and an external portion. The internal portion is inserted by way of an aperture (74) into the interior of the casing (53) and is held in contact with the reservoir (51); the external portion is in contact with the rounded external surface of the teeth (76) of an inking roller (42). The inking roller (42) is always engaged with a drive roller (78) of the pair of rollers (43). A guide bush (41) directs the ribbon (32) towards the teeth (76); the ink (50) passes from the metering means (52) to the rounded surface of the teeth (76). The teeth (76) in turn transfer the ink (50) to the ribbon (32) which is engaged with the rollers (43). The metering means (52), the inking roller (42) and the ribbon (32) are of the same height, thus providing for uniform re-inking of the ribbon (32) during the feed of the ribbon.

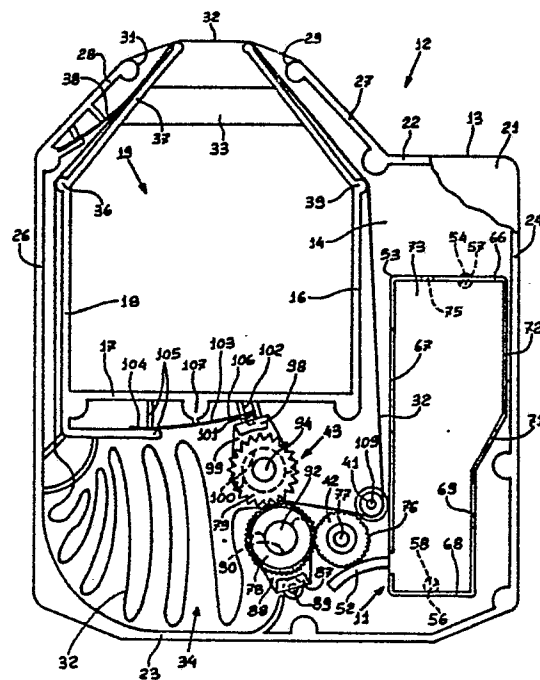

FIG.1

EP 0 313 245 A2

CARTRIDGE FOR AN INKED RIBBON WITH A RE-INKING DEVICE

The present invention relates to a cartridge for an inked ribbon with a re-inking device, of the type set forth in the introductory part of claim 1.

In a known cartridge of that type the ink metering means comprises a blade which is in contact with a roller in contact with the ribbon and which provides for the ribbon feed. The ink metering means is partially housed in an inking reservoir which in turn is accommodated in a recess in the container; a spring urges the entire inking reservoir, with its metering means towards the feed roller. That re-inking device suffers from the disadvantage that the inking reservoir can allow the ink to be easily drawn out. In addition the form of the feed roller which is subdivided into rings and the essential purpose of which is to engage the ribbon for the feed thereof is not suitable for providing for regular distribution of the ink over the ribbon to be re-inked.

The object of the present invention is therefore to provide a re-inking device for an inked ribbon in a cartridge, of low cost, which is simple, reliable and which at the same time permits uniform re-inking of the ribbon.

This object is met by the cartridge for an inked ribbon with a re-inking device according to the invention, which is characterised in the manner set forth in claim 1.

A preferred embodiment of the present invention is set forth in the following description which is given by way of non-limiting example with reference to the accompanying drawings in which:

Figure 1 is a plan view of part of a cartridge with the re-inking device according to the invention,

Figure 2 is a plan view of part of the re-inking device of Figure 1, on an enlarged scale,

Figure 3 is a front view in section of part of some details from Figure 1, on an enlarged scale, and

Figure 4 is a plan view of part of other details of Figure 1, on an enlarged scale.

Referring to Figure 1, the re-inking device which is generally indicated at 11 is applied by way of example to a cartridge 12 which, not being principal subject-matter of the present invention, is described only in respect of part thereof in order better to set forth the use of the re-inking device 11. In particular the cartridge 12 comprises a container 13 having a bottom 14 and a series of internal walls 16, 17 and 18 such as to define a space 19. The container 13 is closed upwardly by a cover 21 and is delimited by a rear wall 22, a front wall 23, a right-hand side wall 24 and a left-hand side wall 26.

The cartridge 12 comprises, projecting from the rear wall 22, two arms 27 and 28 which are suitably shaped and which at their ends have two apertures 29 and 31 respectively for permitting a portion of an inked ribbon 32 to pass therethrough and be guided to the outside. The arms 27 and 28 are connected by a reinforcing rib 33. The inked ribbon 32 is of the closed loop type and is disposed in randomly distributed turns in a magazine 34 in the container 13.

The inked ribbon 32 issued from the magazine 34 and, guided by a fixed guide 36, is pinched between an internal wall 37 of the arm 28 and a resilient blade 38 to prevent a plurality of loops from escaping and to permit tensioning of the ribbon. The ribbon 32 issues from the container 13 by way of the aperture 31, returns into the container 13 through the aperture 29 and is guided to the interior of the container by a fixed guide 39 and a guide bush 41 to be directed in tangential relationship and in contact with an inking roller 42. The ribbon 32 is then engaged by a pair of rollers which are generally indicated at 43 for the unidirectional feed movement and is re-introduced into the magazine 34.

The re-inking device 11 comprises a supply reservoir for the ink as indicated at 51 (see Figure 2), comprising a soft porous body of low density formed for example by a polyester felt pad and capable of containing the ink 50 by impregnation, and an ink metering means 52 comprising a porous but compact body of high density and of reasonable rigidity, formed for example by a felt of wool which is treated with epoxy resin. The ink metering means 52 has a first portion in close contact with the supply reservoir 51 and a second portion in contact with the inking roller 42 for permitting capillary flow of the ink 50 from the reservoir 51 to the inking roller 42. The reservoir for the ink or polyester felt pad 51 is protected from losing ink 50 by a casing formed by a closed cassette or box 53 which in turn is housed within the container 13 (see Figure 1). The box 53 comprises two recesses 54 and 56 for accommodating two positioning pins 57 and 58 which project from the bottom 14, within the container 13, for removably fixing the box 53 to the container 13, positioning it adjacent to a portion of the ribbon 32, the guide bush 41 and the inking roller 42, as is clearly visible in Figure 1. The box 53 comprises two internal blades 59 (see Figure 2) and 61 and two pins 62 and 63 arranged for positioning on the one hand the polyester felt 51 and for holding a part of the metering means 52 closely in contact against the polyester felt 51 by virtue of the compliance of the material. The box

53 having the recesses 54 and 56 is formed by a bottom 64 and a series of walls 66, 67, 68, 69, 71 (see Figure 1), and 72 each having a rebate 65 at its upper edge.

The box 53 is closed in known fashion, for example a cover 73 is ultrasonically welded to the rebates 65 of the walls 66, 67, 68, 69, 71 and 72 after the reservoir 51 and the metering means 52 have been positioned within the box 53. In addition the box 53 comprises a lateral opening 74 (see Figure 2) to permit the metering means 52 to be passed therethrough and positioned therein. The opening 74 is of a predetermined shape of frustoconical section such as to reduce and slightly compress the part of the metering means 52 which is accommodated in the opening 74, in such a way as to prevent leakage of the ink 50 contained in the reservoir 51, except for that which passes by capillary flow along the fibres of the metering means 52. The ink 50 is introduced into the box 53 after the box is sealingly closed, in per se known manner, for example using a syringe system for injecting a predetermined amount which is preset such as to be completely absorbed by the reservoir 51 and the metering means 52, by way of a small hole 75 provided in the wall 66. The internal blades 59 and 61 are spaced from the wall 66 in such a way as to form a space 80 which is kept at ambient pressure by virtue of the presence of the hole 75 and capable of ensuring a normal discharge flow of ink 50 by way of the metering means 52.

The pins 62 and 63 are spaced from the wall 68 to form a space 85 adjacent to the aperture 74. The pins 62 and 63 of the box and the opening 74 define a reference axis 70 for the metering means 52, which is substantially parallel to the wall 68.

The positioning pins 57 (see Figure 1) and 58 of the container 13 predetermine a position of the box 53 within the container such that the axis 70 of the metering means 52 is disposed along a plane intermediate reference plane tangential to the periphery and a plane passing through the axis of the inking roller 42, both parallel to the wall 68. The projecting portion of the metering means 52 is obliged to flex and bears against the outside surface of the teeth 76 of the roller 42. In addition it tends to return to its original position due to the resiliency of the materials of which it is composed and therefore applies a pressure in the region of contact with the outside surface of the teeth 76, which is sufficient to ensure that the ink passes on to the teeth 76. The inking roller 42 is rotatable on a pin 77 which projects from the bottom 14, and has the tips of the teeth 76 of rounded section (see Figure 4) so as not to cause wear on the ribbon 32 and the portion of the metering means 52 (see Figure 1) which are held in contact with the teeth 76. Capillary flow of the ink 50 from the metering

means 52 to the outside surface of the teeth 76 and subsequently to the ribbon 32 therefore takes place in a smooth and reliable fashion.

The pair of rollers 43 comprise a toothed drive roller 78 which is always engaged with the inking roller 42 and a toothed drive roller 79. The drive and driven rollers 78 and 79 are each formed in one piece comprising three toothed wheels or gears which are spaced from each other by two sleeve portions 81 (see Figure 3) and 82. The drive roller 78 is rotatable between an opening 83 in the bottom 14 and an opening 84 in the cover 21 and can be connected in per se known manner for example to a drive shaft 86 which is substantially similar to the drive shaft 66 shown in Figure 3 of Italian patent No 1 024 899 when the cartridge 12 is mounted on a typewriter. The drive roller 78 is supported by a support 87 having two flanges 88 with semicylindrical seats 90 engaged with the two sleeve portions 81 and a pin 89 which is housed in a cylindrical seat 91 in the bottom 14. The drive roller 78 has a gripping portion 92 which projects from the cover 21 and which is capable of being manually rotated for manual feed of the inked roller 32.

The driven roller 79 is rotatable by means of the end portions 93 and 94 which are accommodated in respective slots 96 and 97 in the bottom 14 and the cover 21. The driver roller 79 is supported by a pressing support 98 having two flanges 99 with semicylindrical seats 100 engaged with the two sleeves 82 and a cylindrical pin 101 housed in a radial groove 102 in the bottom 14. A leaf spring 103 has one end 104 (see Figure 1) received in a recess 105 in the container 13, with the other end 106 engaged with the pressing means 98 and an intermediate portion co-operating with a preloading member 107 of the container 13 for holding the driven toothed roller 79 constantly in mesh and engaged with the drive toothed roller 78. The structure of the rollers 78 and 79 and the associated supports 87 and 98 as described hereinbefore is optimised to produce feed movement of the ribbon without obstruction and jamming in per se known manner.

The cover 21 (see Figure 3) comprises ribs 108 capable of co-operating with the upper portions of the support 87, the pressing means 98 and the rollers 78 and 79 to prevent undesired movements of the various components when the cartridge 12 is not mounted on the typewriter.

The guide bush 41 (see Figure 1) is rotatable on a pin 109 on the bottom 14 and the ribbon 32 is engaged around the guide bush 41 to be directed towards the teeth 76 of the inking roller 42 and subsequently towards the pair of rollers 43, following an inclined path of movement as shown in Figure 4.

The ink metering means 52 (see Figures 1 and 2) is of substantially parallelepipedic form and is of a height equal to the height of the inking roller 42, the guide bush 41 and the inked ribbon 32. When the cartridge 12 is mounted on a typewriter, the drive shaft 86 rotates with the drive roller 78 and the driven roller 79 and the inked ribbon 32 is moved with a unidirectional feed movement. The projecting portion of the metering means 52 is always in contact with the teeth 76 of the inking roller 42 and the ink 50 thus flows from the ink reservoir 51 to the rounded external surface of the teeth 76. Since the inking roller 42 is always engaged with the drive roller 78, rotary movement thereof causes rotary movement of the inking roller 42. The teeth 76 engage the ribbon 32 and the ink 50 deposited on the teeth 76 passes to the ribbon 32. That therefore provides for uniform and controlled re-inking of the ribbon 32.

It will be apparent therefore that the reservoir 51 and a part of the metering means 52 are housed in a closed box 53 having a single opening 74 for the metering means 52 to pass therethrough; the ink 50 cannot therefore escape from any part of the arrangement, except by way of the metering means 52. As the box 53 does not lose ink 50, it permits assembly of the reservoir 51 and the metering means 52, and loading of the ink 50 and subsequent storage of the box, as a unit which is separate and separable from the cartridge. In addition if the cartridge 12 is designed for that purpose, it is possible to replace an exhausted box by a fresh box.

It will be appreciated that the cartridge 12 for an inked ribbon 32 with the re-inking device 11 may be the subject of modifications and improvements both in regard to the shape and the arrangement of the various components and parts without departing from the scope of the invention.

Claims

1. A cartridge for an inked ribbon (32) with a re-inking device (11), of the type comprising a container (13) having a magazine (34) for accommodating the ribbon (32) and a pair of rollers (43) for the feed movement of the ribbon, and in which the re-inking device (11) comprises an ink reservoir (51) and an ink metering means (52) characterized by a casing (53) for the reservoir (51) for the ink and an inking roller (42) engaged with the metering means for the capillary flow of the ink from the reservoir (51) to the inking roller, and in that the inking roller (42) is toothed overall and is in engagement with a roller of the pair of rollers (43).

2. A cartridge according to claim 1, characterized in that the casing (53) is disposed within the container (13) and comprises an aperture (74) and in that the ink metering means (52) has a first portion inserted into the aperture (74) into close contact with the reservoir (51) and a second portion which is held in contact with the inking roller (42).

3. A cartridge according to claim 1 or 2 characterized in that the teeth (76) of the inking roller (42) are disposed on the entire peripheral surface of the roller and have rounded tips and in that the pair of rollers (43) comprise a toothed drive roller (78) and a toothed drive roller (79), in which the toothed drive roller (78) is engaged with the inking roller (42) and resilient means (103) urge the toothed driven roller (79) into engagement with the drive roller (78).

4. A cartridge according to claim 1, 2 and 3, characterized by a pair of pins (109,77) projecting into the interior of the container (13) and a guide bush (41) rotatably mounted on one of the pins (109) wherein the inking roller (42) is rotatably mounted on the other pin (77), and wherein the inked ribbon (32) is engaged around the guide bush (41) to be directed towards and into contact with teeth (76) of the inking roller (42) and subsequently towards the teeth of the pair of rollers (43).

5. A cartridge according to claim 4, characterized in that the inked ribbon (32) is of the closed loop type and is disposed in turns which are randomly distributed within the magazine (34) and in that the pair of rollers (43), the inking roller (42) and the guide bush (41) are disposed between the magazine (34) and the casing (53).

6. A cartridge according to any of claims 1 to 5, characterized in that the container (13) has a bottom (14) from which two positioning pins (57,58) project into the interior of the container (13) and which are capable of being accommodated in corresponding seats (54,56) in the casing (53) for removably fixing the casing to the container (13) and for positioning it adjacent to the inking roller (42).

7. A cartridge according to claim 2 and claim 6, characterized in that the two positioning pins (57,58) position the casing (53) in such a way that the said aperture (74) is disposed in a plane (70) intermediate planes tangential to the periphery and passing through the axis of the inking roller (42) and such that the second portion of the ink metering means (52) projecting from the casing (53) flexes and bears resiliently against the teeth (76) of the inking roller (42).

8. A cartridge according to any of claims 1 to 7 characterized in that the container (13) has a cover (21) and a bottom (14), the rollers of the pair of rollers (43) each comprise three toothed wheels (78,79) which are spaced from each other by two

sleeves (81,82) which are fixed with respect to the three wheels (78,79), the drive roller (78) is rotatable between two openings (83,84) in the bottom (14) and the cover (21) and is supported by a support (87) having two flanges (88) with semicylindrical seats (90) engaged with the respective sleeves (81) and a pin (89) accommodated in a cylindrical seat (91) in the bottom (14) and the driven roller (79) is supported by a pressing means (98) having two flanges (99) with semicylindrical seats (100) engaged with the respective sleeves (82), and a pin (101) accommodated in a radial groove (102) in the bottom (14).

9. A cartridge according to claim 3 and claim 8, characterized in that the resilient means comprise a leaf spring (103) having an end portion (104) accommodated in a seat (105) of the container (13), the other end portion (106) engaged with the pressing means (98) and an intermediate portion engaged with a pre-loading element (107) of the container (13).

10. A cartridge according to any of claims 1 to 9 characterized in that the inking roller (42) the ink metering means (52) and the inked ribbon (32) are of the same height and in that the ink metering means is of a substantially parallelepipedic shape.

11. A cartridge for an inked ribbon (32) with a re-inking device (11), of the type comprising a container (13) having a magazine (34) for accommodating the ribbon (32) and a pair of toothed rollers (43) for the feed movement of the ribbon, and in which the re-inking device (11) comprises an ink reservoir (51) and an ink metering means (52) characterized in that the reservoir (51) for the ink is disposed in a box (53) accommodated within the container (13), the metering means (52) for the ink has a first portion which is inserted into an aperture (74) in the box (53) and held in contact with the reservoir (51) and a second portion which is held in contact with an inking roller (42), for capillary flow of the ink from the reservoir to the inking roller and subsequently to the inked ribbon (32), and wherein the inking roller (42) is engaged with one roller of the said pair of rollers (43) to be driven in rotation by that roller.

12. A cartridge according to claim 11, characterized in that the reservoir (51) for the ink comprises a porous, soft, low-density body formed by a polyester felt capable of containing ink and in that the ink metering means (52) comprises a porous, compact, elastic body of high density formed by a felt of wool which is treated with epoxy resin, capable of permitting capillary flow of the ink from the reservoir (51) to the inking roller (42).

13. A cartridge according to claim 11 or 12, characterized in that the aperture (74) is of a predetermined shape of decreasing section such as to reduce and slightly compress the portion of the

metering means (52) which is accommodated in the aperture and to prevent discharge of the ink contained in the reservoir (51), except for that which passes by way of the metering means.

14. A cartridge according to claim 11, 12 or 13, characterized in that the box (53) comprises a bottom (64), a series of closed walls (66, 67, 68, 69, 71) and a cover (73) and in that the aperture (74) is provided in a wall (67) of the said series.

15. A cartridge according to claim 14, characterized in that the box (53) comprises at least one internal portion (59, 61) projecting from the bottom (64) and spaced from a wall (66) of the said series in such a way as to form a space (80) between the internal portion and that wall, and wherein the space (80) is maintained at ambient pressure through a hole (75) in the wall (66) to guarantee a normal discharge flow of the ink by way of the metering means (52).

16. A cartridge according to any of claims 11 to 15, characterized in that the inking roller (42) is toothed and is always engaged with the said one roller of the pair (43) and in that the second portion of the metering means (52) bears in a flexed condition against the outside surface of the teeth (76) of the inking roller (42) and always remains in contact with that surface by virtue of the resilience of the material which make up the metering means (52).

17. A cartridge according to claim 15, characterized in that the ink reservoir (51) comprises a porous body impregnated with the ink (50) and further comprising positioning means (62, 63) operative on the metering means (52) for causing the contact of the first portion of the metering means (52) with the porous body for capillary flow of the ink (50) and to define a space (85) between the first portion of the metering means and a wall (68) of the said series of walls adjacent to the said aperture (74).

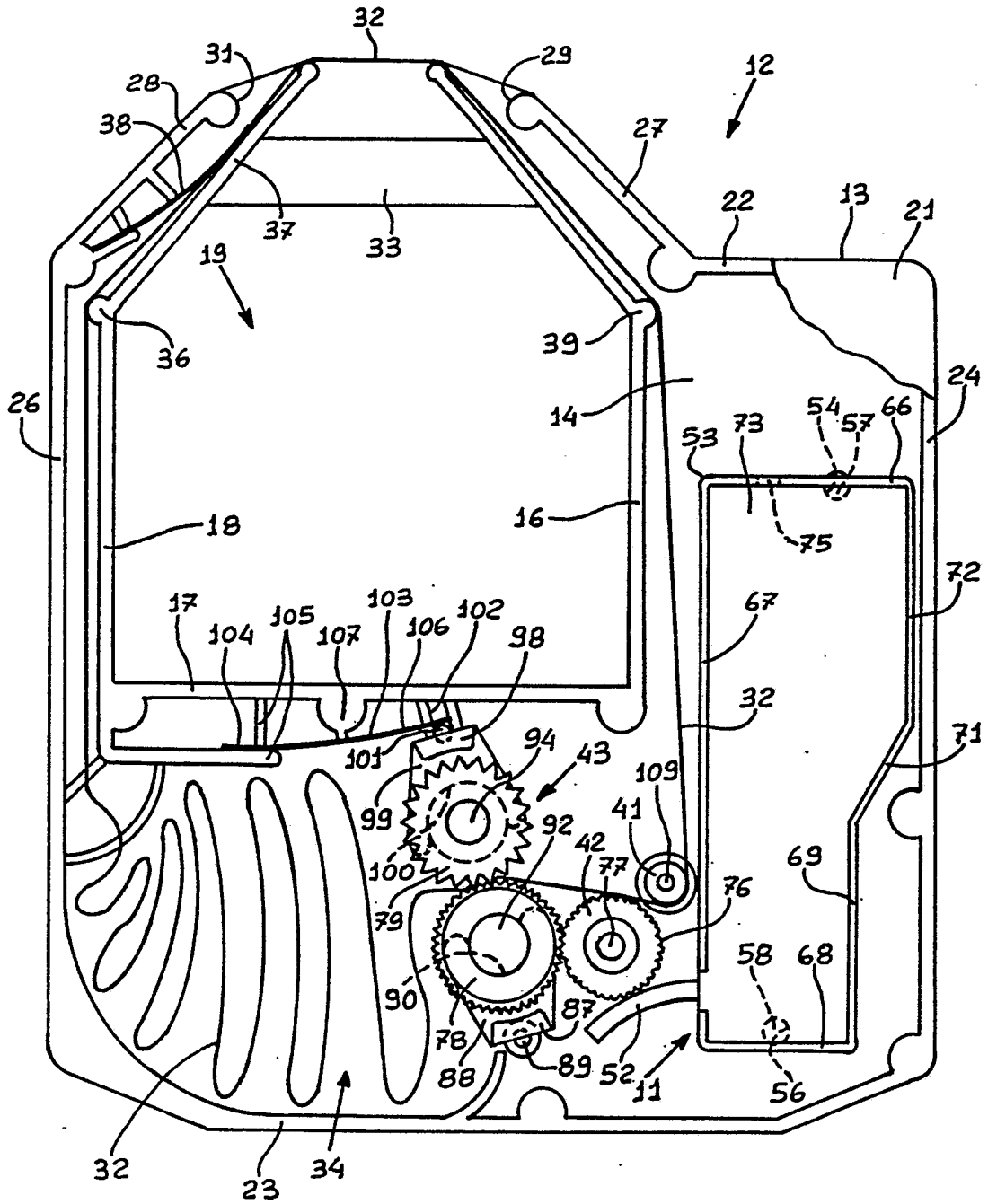

FIG.1

